

**MALLA REDDY COLLEGE OF ENGINEERING AND
TECHNOLOGY**
**Maisammaguda, Dhulapally post, via Hakimpet,
Secunderabad**



**LABORATORY MANUAL
(ELECTRONIC DEVICES & CIRCUITS LAB)**

II B.Tech I-SEM

Prepared by

R.Chinna Rao,

Assistant Professor, Dept. of ECE

Maheshwari,

Assistant Professor, Dept. of ECE

**DEPARTMENT OF
ELECTRONICS & COMMUNICATION ENGINEERING**

BASIC REQUIREMENT FOR EDC LAB

1. BASIC ELECTRONIC COMPONENTS	
1.1 COLOUR CODING OF RESISTORS	4
1.2. COLOUR CODING OF CAPACITORS	5
1.3. COLOUR CODING OF INDUCTORS	9
2. CIRCUIT SYMBOLS	10
3. STUDY OF CRO	18
4. STUDY OF FUNCTION GENERATOR	24
5. STUDY OF REGULATED POWER SUPPLY	27
6. TYPES OF CIRCUIT BOARD	28

LIST OF EXPERIMENTS

1. P-N JUNCTION DIODE CHARACTERISTICS	30
2. ZENER DIODE CHARACTERISTICS AND ZENER AS VOLTAGE REGULATOR	34
3. HALF -WAVE RECTIFIER WITH AND WITHOUT FILTER	39
4. FULL - WAVE RECTIFIER WITH AND WITHOUT FILTER	44
5. INPUT AND OUTPUT CHARACTERISTICS OF TRANSISTOR CB CONFIGURATION	49
6. INPUT AND OUTPUT CHARACTERISTICS OF TRANSISTOR CE CONFIGURATION	53
7. FET CHARACTERISTICS	57
8. h-PARAMETERS OF CB CONFIGURATION	61
9. h-PARAMETERS OF CE CONFIGURATION	65
10. FREQUENCY RESPONSE OF CE AMPLIFIER	69
11. FREQUENCY RESPONSE OF CC AMPLIFIER	73
12. FREQUENCY RESPONSE OF COMMON SOURCE FET AMPLIFIER	77

1. BASIC ELECTRONIC COMPONENTS

1.1. COLOUR CODING OF RESISTOR:

Colour Codes are used to identify the value of resistor. The numbers to the Colour are identified in the following sequence which is remembered as **BBROY GREAT BRITAN VERY GOOD WIFE (BBROYGBVGW)** and their assignment is listed in following table.

Black	Brown	Red	Orange	Yellow	Green	Blue	Violet	Grey	White
0	1	2	3	4	5	6	7	8	9

Table1: Colour codes of resistor

<p>1st digit 2nd digit Multiplier Tolerance Quality</p>	First find the tolerance band, it will typically be gold (5%) and sometimes silver (10%).
	Starting from the other end, identify the first band - write down the number associated with that color
	Now read the next color, so write down a its value next to the first value.
	Now read the third or 'multiplier exponent' band and write down that as the number of zeros.
	If the 'multiplier exponent' band is Gold move the decimal point one to the left. If the 'multiplier exponent' band is Silver move the decimal point two places to the left. If the resistor has one more band past the tolerance band it is a quality band.
	Read the number as the '% Failure rate per 1000 hour' This is rated assuming full wattage being applied to the resistors. (To get better failure rates, resistors are typically specified to have twice the needed wattage dissipation that the circuit produces). Some resistors use this band for temco information. 1% resistors have three bands to read digits to the left of the multiplier. They have a different temperature coefficient in order to provide the 1% tolerance. At 1% the temperature coefficient starts to become an important factor. at +/-200 ppm a change in temperature of 25 Deg C causes a value change of up to 1%

Table2: Procedure to find the value of resistor using colour codes

1.2. COLOUR CODING OF CAPACITORS

An electrical device capable of storing electrical energy. In general, a capacitor consists of two metal plates insulated from each other by a dielectric. The capacitance of a capacitor depends primarily upon its shape and size and upon the relative permittivity ϵ_r of the medium between the plates. In vacuum, in air, and in most gases, ϵ_r ranges from one to several hundred.

One classification of capacitors comes from the physical state of their dielectrics, which may be gas (or vacuum), liquid, solid, or a combination of these. Each of these classifications may be subdivided according to the specific dielectric used. Capacitors may be further classified by their ability to be used in alternating-current (ac) or direct-current (dc) circuits with various current levels.

- **Capacitor Identification Codes:** There are no international agreements in place to standardize capacitor identification. Most plastic film types (Figure 1) have printed values and are normally in microfarads or if the symbol is n, Nanofarads. Working voltage is easily identified. Tolerances are upper case letters: M = 20%, K = 10%, J = 5%, H = 2.5% and F = $\pm 1\text{pF}$.

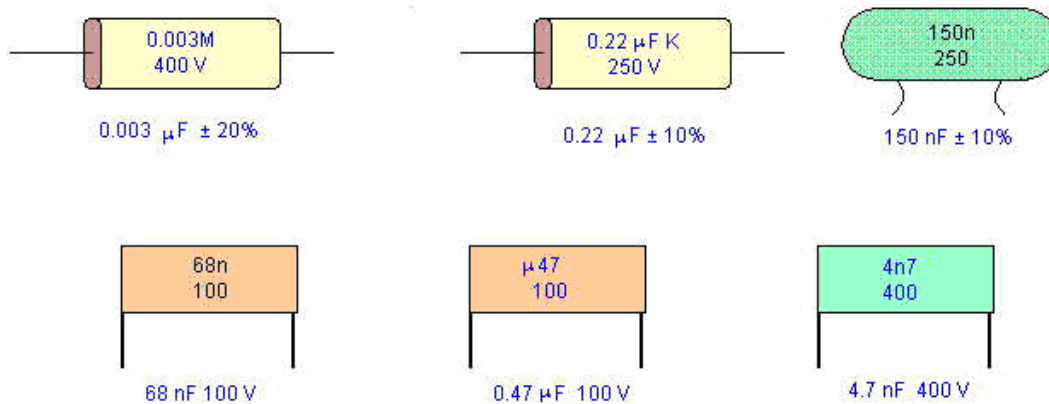

Figure 1: Plastic Film Types

A more difficult scheme is shown in Figure 2 where K is used for indicating Picofarads. The unit is picofarads and the third number is a multiplier. A capacitor coded 474K63 means $47 \times 10000 \text{ pF}$ which is equivalent to 470000 pF or 0.47 microfarads . K indicates 10% tolerance. 50, 63 and 100 are working volts.

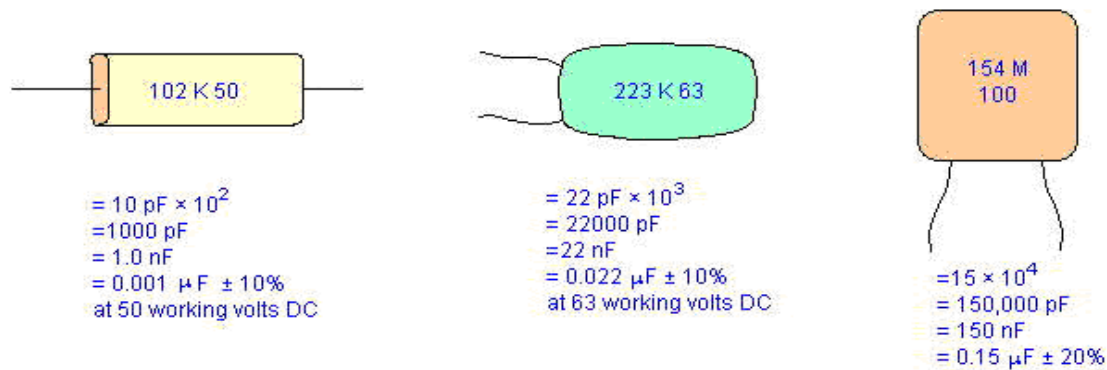

Figure 2: PicoFarads Representation

Ceramic disk capacitors have many marking schemes. Capacitance, tolerance, working voltage and temperature coefficient may be found which is as shown in figure 3. Capacitance values are given as number without any identification as to units. (uF, nF, pF) Whole numbers usually indicate pF and decimal numbers such as 0.1 or 0.47 are microfarads. Odd looking numbers such as 473 is the previously explained system and means 47nf

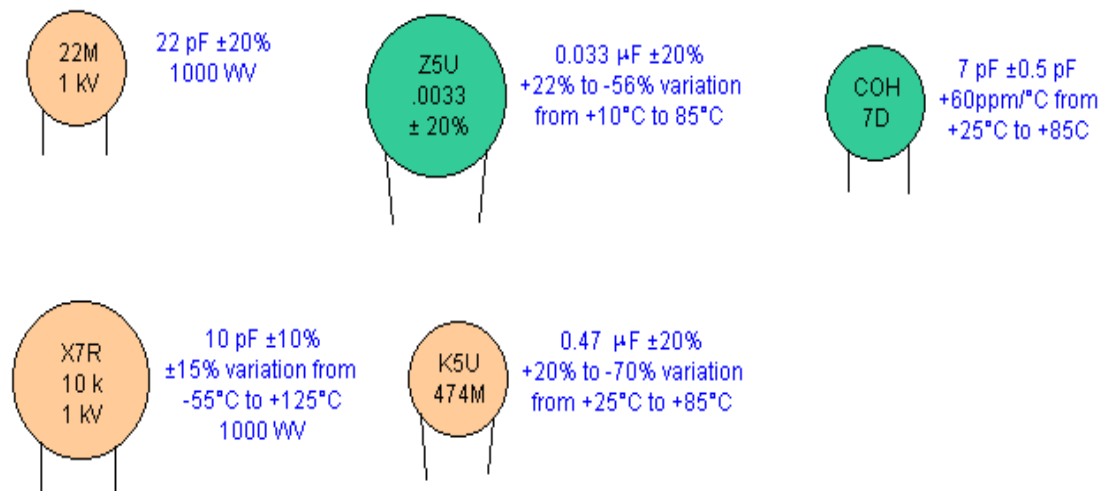

Figure3: Ceramic Disk Capacitor

Figure 4 shows some other miscellaneous schemes.

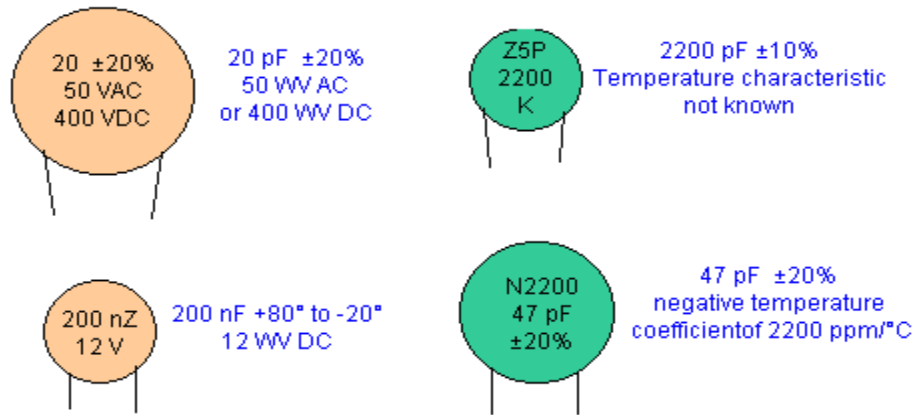

Figure 4: Miscellaneous Schemes.

➤ Electrolytic capacitor properties

There are a number of parameters of importance beyond the basic capacitance and capacitive reactance when using electrolytic capacitors. When designing circuits using electrolytic capacitors it is necessary to take these additional parameters into consideration for some designs, and to be aware of them when using electrolytic capacitors

- ESR Equivalent series resistance:** Electrolytic capacitors are often used in circuits where current levels are relatively high. Also under some circumstances and current sourced from them needs to have low source impedance, for example when the capacitor is being used in a power supply circuit as a reservoir capacitor. Under these conditions it is necessary to consult the manufacturers' datasheets to discover whether the electrolytic capacitor chosen will meet the requirements for the circuit. If the ESR is high, then it will not be able to deliver the required amount of current in the circuit, without a voltage drop resulting from the ESR which will be seen as a source resistance.
- Frequency response:** One of the problems with electrolytic capacitors is that they have a limited frequency response. It is found that their ESR rises with frequency and this generally limits their use to frequencies below about 100 kHz. This is particularly true for large capacitors, and even the smaller electrolytic capacitors should not be relied upon at high frequencies. To gain exact details it is necessary to consult the manufacturer's data for a given part.

- **Leakage:** Although electrolytic capacitors have much higher levels of capacitance for a given volume than most other capacitor technologies, they can also have a higher level of leakage. This is not a problem for most applications, such as when they are used in power supplies. However under some circumstances they are not suitable. For example they should not be used around the input circuitry of an operational amplifier. Here even a small amount of leakage can cause problems because of the high input impedance levels of the op-amp. It is also worth noting that the levels of leakage are considerably higher in the reverse direction.
- **Ripple current:** When using electrolytic capacitors in high current applications such as the reservoir capacitor of a power supply, it is necessary to consider the ripple current it is likely to experience. Capacitors have a maximum ripple current they can supply. Above this they can become too hot which will reduce their life. In extreme cases it can cause the capacitor to fail. Accordingly it is necessary to calculate the expected ripple current and check that it is within the manufacturer's maximum ratings.
- **Tolerance:** Electrolytic capacitors have a very wide tolerance. Typically this may be -50% + 100%. This is not normally a problem in applications such as decoupling or power supply smoothing, etc. However they should not be used in circuits where the exact value is of importance.
- **Polarization:** Unlike many other types of capacitor, electrolytic capacitors are polarized and must be connected within a circuit so that they only see a voltage across them in a particular way.

The physical appearance of electrolytic capacitor is as shown in Figure 5. The capacitors themselves are marked so that polarity can easily be seen. In addition to this it is common for the can of the capacitor to be connected to the negative terminal.



Figure 5: Electrolytic Capacitor

It is absolutely necessary to ensure that any electrolytic capacitors are connected within a circuit with the correct polarity. A reverse bias voltage will cause the centre oxide layer forming the dielectric to be destroyed as a result of electrochemical reduction. If this occurs a short circuit will appear and excessive current can cause the capacitor to become very hot. If this occurs the component may leak the electrolyte, but under some circumstances they can explode. As this is not uncommon, it is very wise to take precautions and ensure the capacitor is fitted correctly, especially in applications where high current capability exists.

1.3. COLOUR CODING OF INDUCTORS

Inductor is just coil wound which provides more reactance for high frequencies and low reactance for low frequencies.

Molded inductors follow the same scheme except the units are usually micro henries. A brown-black-red inductor is most likely a 1000 μH . Sometimes a silver or gold band is used as a decimal point. So a red-gold-violet inductor would be a 2.7 μH . Also expect to see a wide silver or gold band before the first value band and a thin tolerance band at the end. The typical Colour codes and their values are shown in Figure 6.

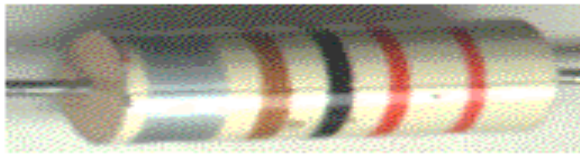

1000 μH (1millihenry), 2%

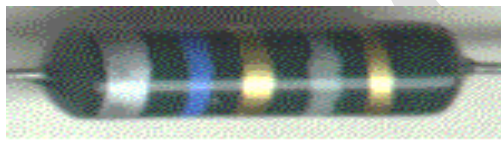



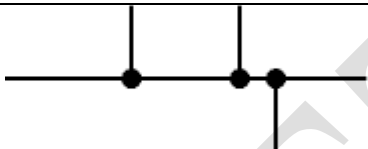
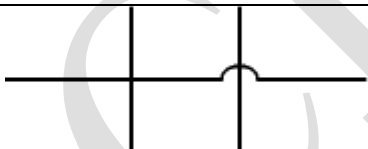
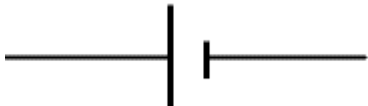
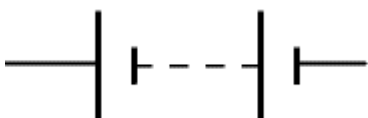

6.8 μH , 5%

Figure 6: Typical inductors colour coding and their values.

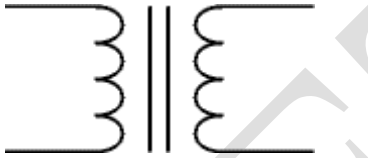

2. CIRCUIT SYMBOLS

WIRES AND CONNECTIONS			
S.NO	COMPONENT NAME	CIRCUIT SYMBOL	FUNCTION
1	WIRE		To pass current very easily from one part of a circuit to another.
2	WIRES JOINED		A 'blob' should be drawn where wires are connected (joined), but it is sometimes omitted. Wires connected at 'crossroads' should be staggered slightly to form two T-junctions, as shown on the right.
3	WIRES NOT JOINED		In complex diagrams it is often necessary to draw wires crossing even though they are not connected. I prefer the 'bridge' symbol shown on the right because the simple crossing on the left may be misread as a join where you have forgotten to add a 'blob'.
POWER SUPPLIES			
S.NO	COMPONENT NAME	CIRCUIT SYMBOL	FUNCTION
1	CELL		Supplies electrical energy. The larger terminal (on the left) is positive (+). A single cell is often called a battery, but strictly a battery is two or more cells joined together
2	BATTERY		Supplies electrical energy. A battery is more than one cell. The larger terminal (on the left) is positive (+).

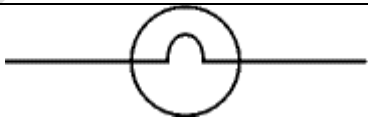
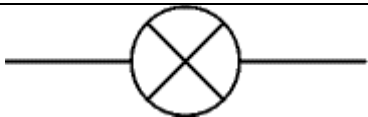
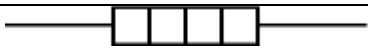

3	DC SUPPLY		Supplies electrical energy. DC = Direct Current, always flowing in one direction.
4	AC SUPPLY		Supplies electrical energy. AC = Alternating Current, continually changing direction.
5	FUSE		A safety device which will 'blow' (melt) if the current flowing through it exceeds a specified value.
6	TRANSFORMER		Two coils of wire linked by an iron core. Transformers are used to step up (increase) and step down (decrease) AC voltages. Energy is transferred between the coils by the magnetic field in the core. There is no electrical connection between the coils.
7	EARTH(GROUND)		A connection to earth. For many electronic circuits this is the 0V (zero volts) of the power supply, but for mains electricity and some radio circuits it really means the earth. It is also known as ground.

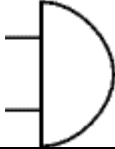
Output Devices: Lamps, Heater, Motor, etc.

S.NO	COMPONENT NAME	CIRCUIT SYMBOL	FUNCTION
1	LAMP(LIGHTING)		A transducer which converts electrical energy to light. This symbol is used for a lamp providing illumination, for example a car headlamp or torch bulb
2	LAMP(INDICATOR)		A transducer which converts electrical energy to light. This symbol is used for a lamp which is an indicator, for example a warning light on a car dashboard.
3	HEATER		A transducer which converts electrical energy to heat.

4	MOTOR		A transducer which converts electrical energy to kinetic energy (motion).
5	BELL		A transducer which converts electrical energy to sound.
6	BUZZER		A transducer which converts electrical energy to sound.
7	INDUCTOR(SOLIN OID,COIL)		A coil of wire which creates a magnetic field when current passes through it. It may have an iron core inside the coil. It can be used as a transducer converting electrical energy to mechanical energy by pulling on something.

Switches

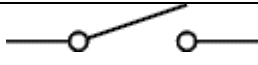
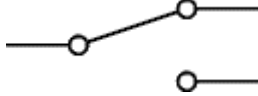
S.NO	COMPONENT NAME	CIRCUIT SYMBOL	FUNCTION
1	PUSH SWITCH(PUSH TO MAKE)		A push switch allows current to flow only when the button is pressed. This is the switch used to operate a doorbell.
2	PUSH TO BREAK SWITCH		This type of push switch is normally closed (on), it is open (off) only when the button is pressed.
3	ON/OFF SWITCH(SPST)		SPST = Single Pole, Single Throw. An on-off switch allows current to flow only when it is in the closed (on) position.
4	2 WAY SWITCH(SPDT)		SPDT = Single Pole, Double Throw. A 2-way changeover switch directs the flow of current to one of two routes according to its position. Some SPDT switches have a central off position and are described as 'on-off-on'.

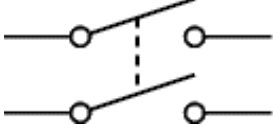
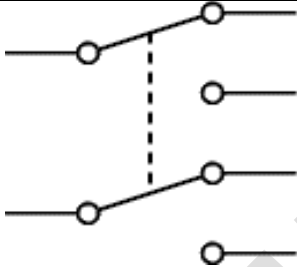
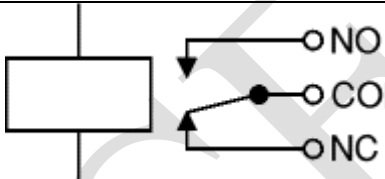

5	DUAL ON-OFF SWITCH(DPST)		<p>DPST = Double Pole, Single Throw. A dual on-off switch which is often used to switch mains electricity because it can isolate both the live and neutral connections.</p>
6	REVERSING SWITCH(DPDT)		<p>DPDT = Double Pole, Double Throw. This switch can be wired up as a reversing switch for a motor. Some DPDT switches have a central off position.</p>
7	RELAY		<p>An electrically operated switch, for example a 9V battery circuit connected to the coil can switch a 230V AC mains circuit. NO = Normally Open, COM = Common, NC = Normally Closed.</p>

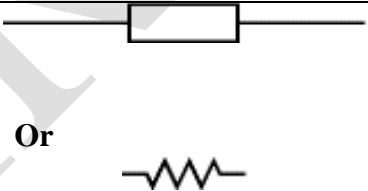
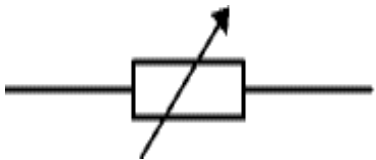
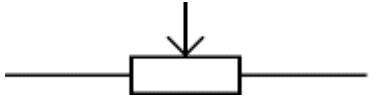

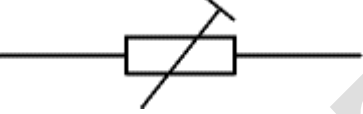

RESISTORS

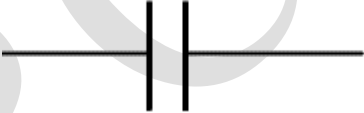
S.NO	COMPONENT NAME	CIRCUIT SYMBOL	FUNCTION
1	RESISTOR		<p>A resistor restricts the flow of current, for example to limit the current passing through an LED. A resistor is used with a capacitor in a timing circuit.</p>
2	VARIABLE RESISTOR(RHEOSTAT)		<p>This type of variable resistor with 2 contacts (a rheostat) is usually used to control current. Examples include: adjusting lamp brightness, adjusting motor speed, and adjusting the rate of flow of charge into a capacitor in a timing circuit.</p>
3	VARIABLE RESISTOR(POTENTIOMETER)		<p>This type of variable resistor with 3 contacts (a potentiometer) is usually</p>

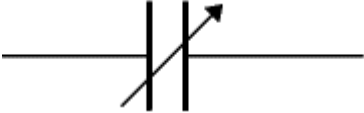
			used to control voltage. It can be used like this as a transducer converting position (angle of the control spindle) to an electrical signal
4	VARIABLE RESISTER(PRESET)		This type of variable resistor (a preset) is operated with a small screwdriver or similar tool. It is designed to be set when the circuit is made and then left without further adjustment. Presets are cheaper than normal variable resistors so they are often used in projects to reduce the cost

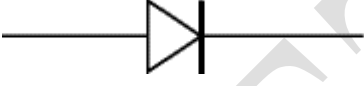



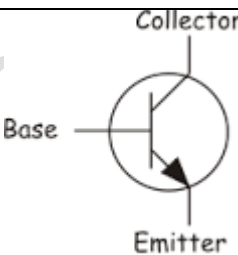
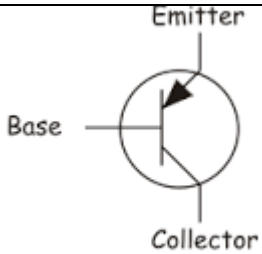

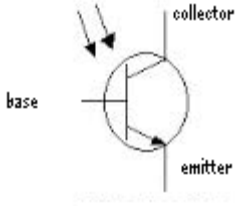
CAPACITORS



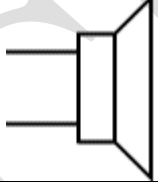

S.NO	NAME OF THE COMPONENT	CIRCUIT SYMBOL	FUNCTION OF THE COMPONENT
1	CAPACITOR		A capacitor stores electric charge. A capacitor is used with a resistor in a timing circuit. It can also be used as a filter, to block DC signals but pass AC signals.
2	CAPACITOR POLARISED		A capacitor stores electric charge. This type must be connected the correct way round. A capacitor is used with a resistor in a timing circuit. It can also be used as a filter, to block DC Signals but pass AC signals.
3	VARIABLE CAPACITOR		A variable capacitor is used in a radio tuner.

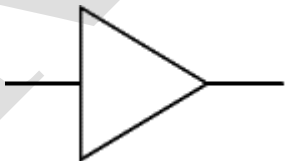
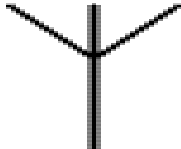
4	TRIMMER CAPACITOR		This type of variable capacitor (a trimmer) is operated with a small screwdriver or similar tool. It is designed to be set when the circuit is made and then left without further adjustment
DIODES			
S.NO	NAME OF THE COMPONENT	CIRCUIT SYMBOL	FUNCTION OF THE COMPONENT
1	DIODE		A device which only allows current to flow in one direction
2	LED(LIGHT EMITTING DIODE)		A transducer which converts electrical energy to light.
3	ZENER DIODE		A special diode which is used to maintain a fixed voltage across its terminals
4	PHOTO DIODE		A light-sensitive diode.
TRANSISTORS			
S.NO	NAME OF THE COMPONENT	CIRCUIT SYMBOL	FUNCTION OF THE COMPONENT
1	TRANSISTOR NPN		A transistor amplifies current. It can be used with other components to make an amplifier or switching circuit.
2	TRANSISTOR PNP		A transistor amplifies current. It can be used with other components to make an amplifier or switching circuit.

3	PHOTO TRANSISTOR		A light-sensitive transistor.
---	------------------	---	-------------------------------

AUDIO AND RADIO DEVICES

S.NO	NAME OF THE COMPONENT	CIRCUIT SYMBOL	FUNCTION OF THE COMPONENT
1	MICROPHONE		A transducer which converts sound to electrical energy.
2	EARPHONE		A transducer which converts electrical energy to sound.
3	LOUD SPEAKER		A transducer which converts electrical energy to sound.
4	PIEZO TRANSDUCER		A transducer which converts electrical energy to sound.
5	AMPLIFIER(GENERAL SYMBOL)		An amplifier circuit with one input. Really it is a block diagram symbol because it represents a circuit rather than just one component.
6	ARIEL (ANTENNA)		A device which is designed to receive or transmit radio signals. It is also known as an antenna
S.NO	NAME OF THE COMPONENT	CIRCUIT SYMBOL	FUNCTION OF THE COMPONENT
1	VOLTMETER		A voltmeter is used to measure voltage. The Proper name for voltage is 'potential difference', but most people prefer to say voltage.

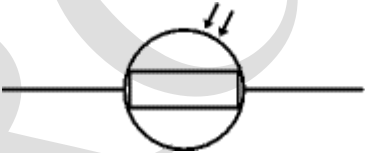
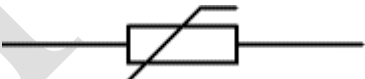
2	AMMETER		An ammeter is used to measure current
3	GALVANOMETER		A galvanometer is a very sensitive meter which is used to measure tiny currents, usually 1mA or less
4	OHMMETER		An ohmmeter is used to measure resistance. Most multimeters have an ohmmeter setting.
5	OSCILLOSCOPE		An oscilloscope is used to display the shape of electrical signals and it can be used to measure their voltage and time period.
Sensors (input devices)			
S.NO	NAME OF THE COMPONENT	CIRCUIT SYMBOL	FUNCTION OF THE COMPONENT
1	LDR		A transducer which converts brightness (light) to resistance (an electrical property). LDR = Light Dependent Resistor
2	THERMISTOR		A transducer which converts temperature (heat) to resistance (an electrical property).

3. STUDY OF CRO

An oscilloscope is a test instrument which allows us to look at the 'shape' of electrical signals by displaying a graph of voltage against time on its screen. It is like a voltmeter with the valuable extra function of showing how the voltage varies with time. A graticule with a 1cm grid enables us to take measurements of voltage and time from the screen.

The graph, usually called the trace, is drawn by a beam of electrons striking the phosphor coating of the screen making it emit light, usually green or blue. This is similar to the way a television picture is produced.

Oscilloscopes contain a vacuum tube with a cathode (negative electrode) at one end to emit electrons and an anode (positive electrode) to accelerate them so they move rapidly down the tube to the screen. This arrangement is called an electron gun. The tube also contains electrodes to deflect the electron beam up/down and left/right.

The electrons are called cathode rays because they are emitted by the cathode and this gives the oscilloscope its full name of cathode ray oscilloscope or CRO.

A dual trace oscilloscope can display two traces on the screen, allowing us to easily compare the input and output of an amplifier for example. It is well worth paying the modest extra cost to have this facility.

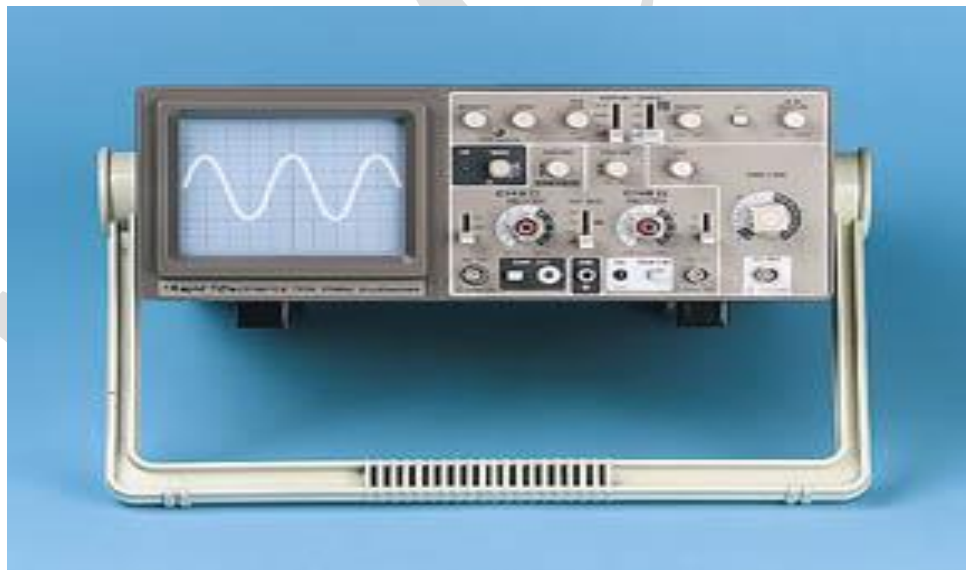

Figure1: Front Panel of CRO

▪ **BASIC OPERATION:**

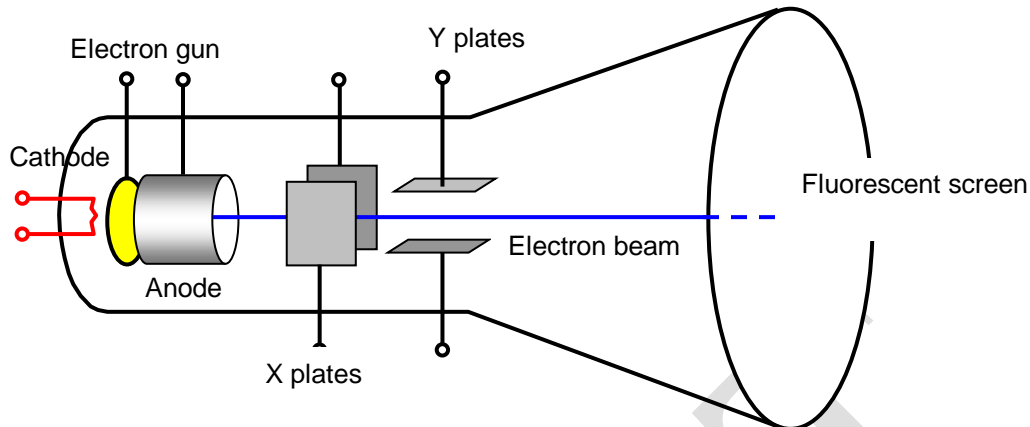

Figure2: Internal Blocks of CRO

➤ **Setting up an oscilloscope:**

Oscilloscopes are complex instruments with many controls and they require some care to set up and use successfully. It is quite easy to 'lose' the trace off the screen if controls are set wrongly.

There is some variation in the arrangement and labeling of the many controls so the following instructions may need to be adapted for this instrument.

1. Switch on the oscilloscope to warm up (it takes a minute or two).
2. Do not connect the input lead at this stage.
3. Set the AC/GND/DC switch (by the Y INPUT) to DC.
4. Set the SWP/X-Y switch to SWP (sweep).
5. Set Trigger Level to AUTO.
6. Set Trigger Source to INT (internal, the y input).
7. Set the Y AMPLIFIER to 5V/cm (a moderate value).
8. Set the TIMEBASE to 10ms/cm (a moderate speed).
9. Turn the time base VARIABLE control to 1 or CAL.
10. Adjust Y SHIFT (up/down) and X SHIFT (left/right) to give a trace across the middle of the screen, like the picture.
11. Adjust INTENSITY (brightness) and FOCUS to give a bright, sharp trace.

The following type of trace is observed on CRO after setting up, when there is no input signal connected.

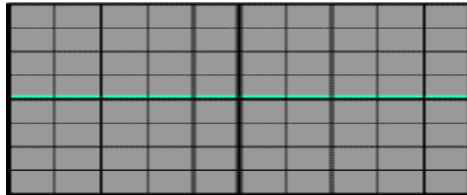

Figure 3: Absence of input signal

➤ **Connecting an oscilloscope:**

The Y INPUT lead to an oscilloscope should be a co-axial lead and the figure 4 shows its construction. The central wire carries the signal and the screen is connected to earth (0V) to shield the signal from electrical interference (usually called noise).

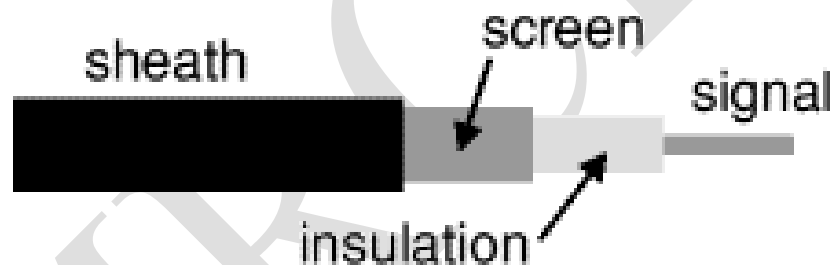

Figure 4: Construction of a co-axial lead

Most oscilloscopes have a BNC socket for the y input and the lead is connected with a push and twist action, to disconnect we need to twist and pull. Professionals use a specially designed lead and probes kit for best results with high frequency signals and when testing high resistance circuits, but this is not essential for simpler work at audio frequencies (up to 20 kHz).



Figure 5: Oscilloscope lead and probes kit

➤ **Obtaining a clear and stable trace:**

Once if we connect the oscilloscope to the circuit, it is necessary to adjust the controls to obtain a clear and stable trace on the screen in order to test it.

- The Y AMPLIFIER (VOLTS/CM) control determines the height of the trace. Choose a setting so the trace occupies at least half the screen height, but does not disappear off the screen.
- The TIMEBASE (TIME/CM) control determines the rate at which the dot sweeps across the screen. Choose a setting so the trace shows at least one cycle of the signal across the screen. Note that a steady DC input signal gives a horizontal line trace for which the time base setting is not critical.
- The TRIGGER control is usually best left set to AUTO.

The trace of an AC signal with the oscilloscope controls correctly set is as shown in Figure 6.

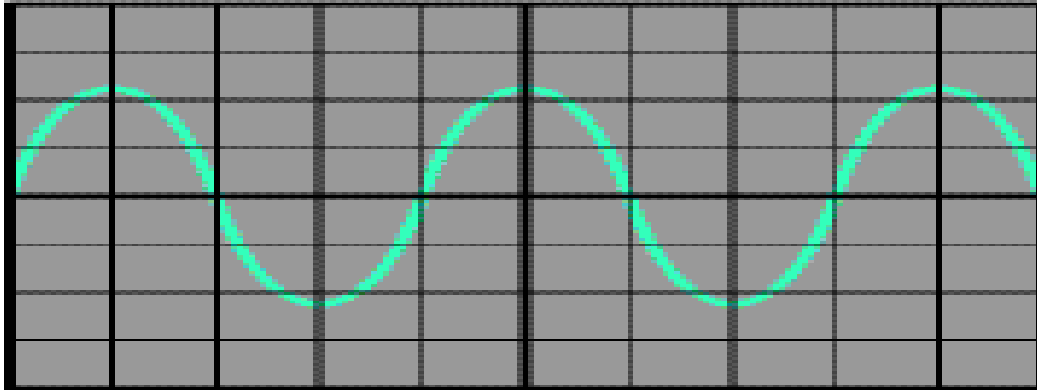

Figure 6 : Stable waveform

➤ **Measuring voltage and time period**

The trace on an oscilloscope screen is a graph of voltage against time. The shape of this graph is determined by the nature of the input signal. In addition to the properties labeled on the graph, there is frequency which is the number of cycles per second. The diagram shows a sine wave but these properties apply to any signal with a constant shape

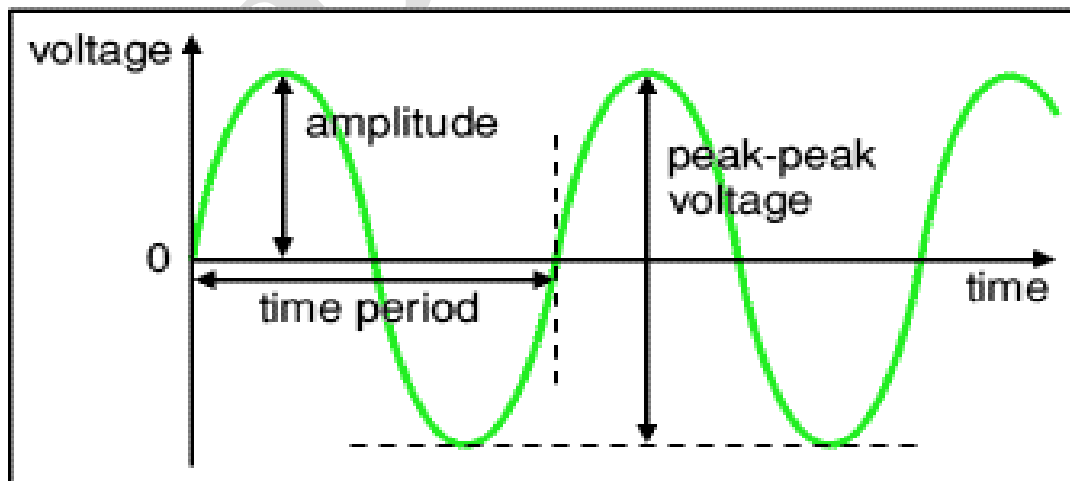

Figure7: Properties of trace

- **Amplitude** is the maximum voltage reached by the signal. It is measured in volts.
- **Peak voltage** is another name for amplitude.
- **Peak-peak voltage** is twice the peak voltage (amplitude). When reading an oscilloscope trace it is usual to measure peak-peak voltage.
- **Time period** is the time taken for the signal to complete one cycle. It is measured in seconds (s), but time periods tend to be short so milliseconds (ms) and microseconds (μs) are often used. $1\text{ms} = 0.001\text{s}$ and $1\mu\text{s} = 0.000001\text{s}$.
- **Frequency** is the number of cycles per second. It is measured in hertz (Hz), but frequencies tend to be high so kilohertz (kHz) and megahertz (MHz) are often used. $1\text{kHz} = 1000\text{Hz}$ and $1\text{MHz} = 1000000\text{Hz}$.

$$\text{Frequency} = \frac{1}{\text{Time period}}$$

$$\text{Time period} = \frac{1}{\text{Frequency}}$$

A) Voltage: Voltage is shown on the vertical y-axis and the scale is determined by the Y AMPLIFIER (VOLTS/CM) control. Usually peak-peak voltage is measured because it can be read correctly even if the position of 0V is not known. The amplitude is half the peak-peak voltage.

$$\text{Voltage} = \text{distance in cm} \times \text{volts/cm}$$

B) Time period: Time is shown on the horizontal x-axis and the scale is determined by the TIMEBASE (TIME/CM) control. The time period (often just called period) is the time for one cycle of the signal. The frequency is the number of cycles per second, frequency = 1/time period.

$$\text{Time} = \text{distance in cm} \times \text{time/cm}$$

4. STUDY OF FUNCTION GENERATOR

A function generator is a device that can produce various patterns of voltage at a variety of frequencies and amplitudes. It is used to test the response of circuits to common input signals. The electrical leads from the device are attached to the ground and signal input terminals of the device under test.



Figure 1: A typical low-cost function generator.

➤ Features and controls :

Most function generators allow the user to choose the shape of the output from a small number of options.

- Square wave - The signal goes directly from high to low voltage.

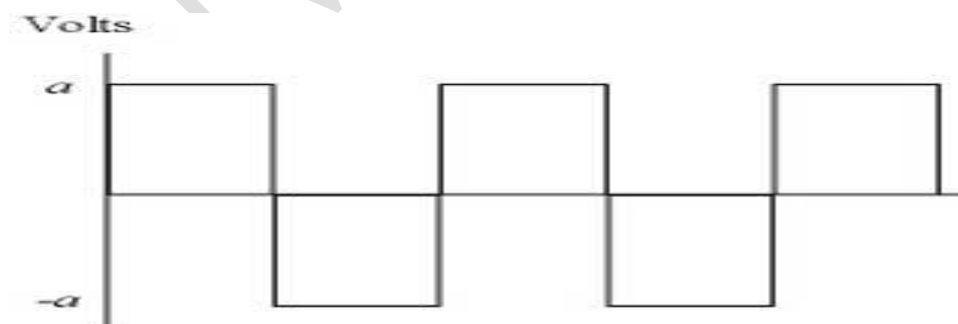

Figure 2: Square wave

The duty cycle of a signal refers to the ratio of high voltage to low voltage time in a square wave signal.

- Sine wave - The signal curves like a sinusoid from high to low voltage.

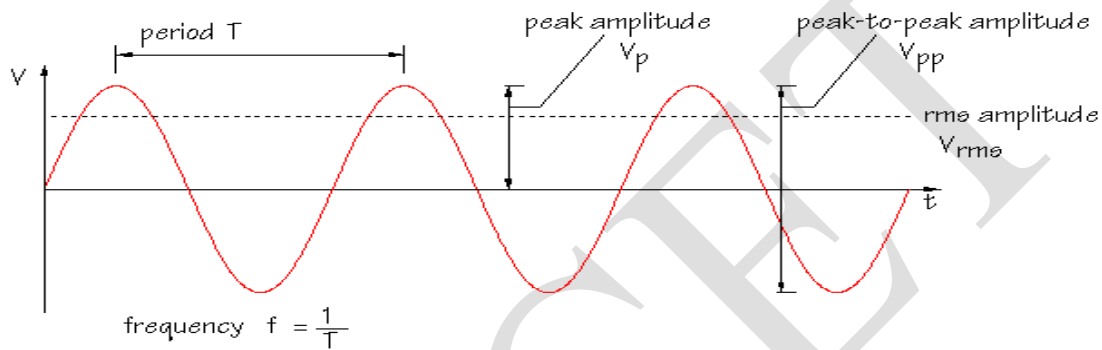

Figure3: Sine Wave

- Triangle wave - The signal goes from high to low voltage at a fixed rate.

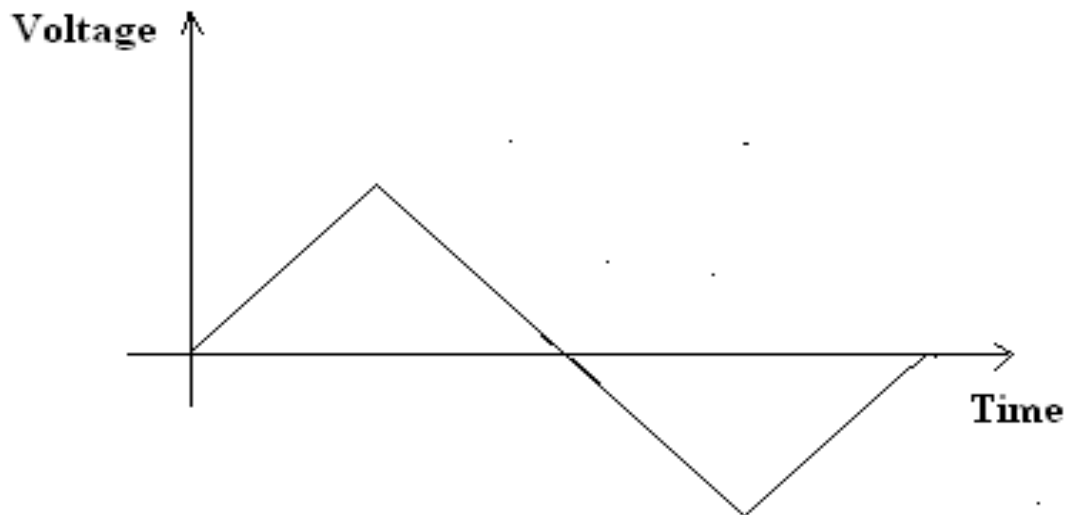

Figure 4: Triangular Wave

The amplitude control on a function generator varies the voltage difference between the high and low voltage of the output signal. The direct current (DC) offset control on a function generator varies the average voltage of a signal relative to the ground.

The frequency control of a function generator controls the rate at which output signal oscillates. On some function generators, the frequency control is a combination of different controls. One set of controls chooses the broad frequency range (order of magnitude) and the other selects the precise frequency. This allows the function generator to handle the enormous variation in frequency scale needed for signals.

➤ **How to use a function generator**

After powering on the function generator, the output signal needs to be configured to the desired shape. Typically, this means connecting the signal and ground leads to an oscilloscope to check the controls. Adjust the function generator until the output signal is correct, then attach the signal and ground leads from the function generator to the input and ground of the device under test. For some applications, the negative lead of the function generator should attach to a negative input of the device, but usually attaching to ground is sufficient.

5. STUDY OF REGULATED POWER SUPPLY

There are many types of power supply. Most are designed to convert high voltage AC mains electricity to a suitable low voltage supply for electronic circuits and other devices. A power supply can be broken down into a series of blocks, each of which performs a particular function. For example a 5V regulated supply:

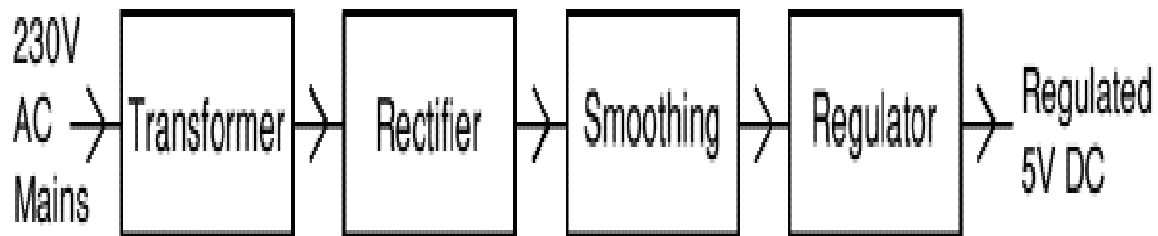

Figure1: Block Diagram Of Regulated Power Supply

Each of the blocks is described in more detail below:

- Transformer: Steps down high voltage AC mains to low voltage AC.
 - Rectifier: Converts AC to DC, but the DC output is varying.
 - Smoothing: Smooths the DC from varying greatly to a small ripple.
 - Regulator: Eliminates ripple by setting DC output to a fixed voltage.
- **Dual Supplies:** Some electronic circuits require a power supply with positive and negative outputs as well as zero volts (0V). This is called a 'dual supply' because it is like two ordinary supplies connected together as shown in the diagram. Dual supplies have three outputs, for example a $\pm 9V$ supply has +9V, 0V and -9V outputs.

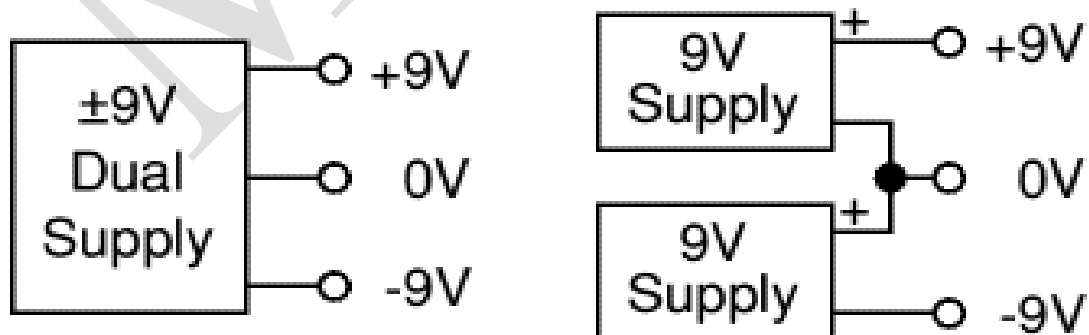

Figure 2: Dual Supply

6. TYPES OF CIRCUIT BOARD

- **Breadboard:** This is a way of making a temporary circuit, for testing purposes or to try out an idea. No soldering is required and all the components can be re-used afterwards. It is easy to change connections and replace components. Almost all the Electronics Club projects started life on a breadboard to check that the circuit worked as intended. The following figure depicts the appearance of Bread board in which the holes in top and bottom stripes are connected horizontally that are used for power supply and ground connection conventionally and holes on middle stripes connected vertically. And that are used for circuit connections conventionally.



Figure 1: Bread board

- **Strip board:**



Figure 2: Strip Board

Stripboard has parallel strips of copper track on one side. The strips are 0.1" (2.54mm) apart and there are holes every 0.1" (2.54mm). Stripboard requires no special preparation other than cutting to size. It can be cut with a junior hacksaw, or simply snap it along the lines of holes by putting it over the edge of a bench or table and pushing hard.

Printed Circuit Board: A printed circuit board, or PCB, is used to mechanically support and electrically connect electronic components using conductive pathways, tracks or traces etched from copper sheets laminated onto a non-conductive substrate. It is also referred to as printed wiring board (PWB) or etched wiring board. A PCB populated with electronic components is a printed circuit assembly (PCA), also known as a printed circuit board assembly (PCBA).

Printed circuit boards have copper tracks connecting the holes where the components are placed. They are designed especially for each circuit and make construction very easy. However, producing the PCB requires special equipment so this method is not recommended if you are a beginner unless the PCB is provided for you.

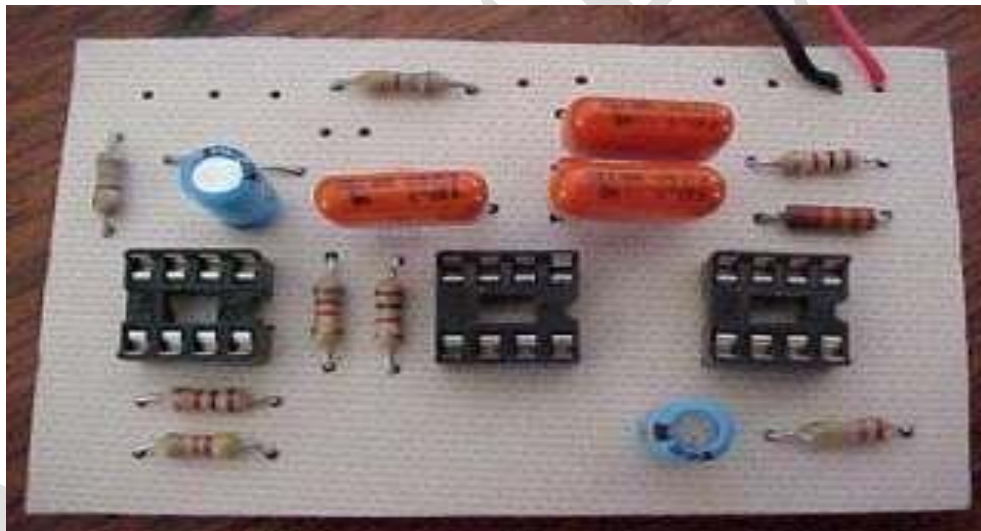

Figure 3: Printed circuit board

PCBs are inexpensive, and can be highly reliable. They require much more layout effort and higher initial cost than either wire-wrapped or point-to-point constructed circuits, but are much cheaper and faster for high-volume production. Much of the electronics industry's PCB design, assembly, and quality control needs are set by standards that are published by the IPC organization.

1. P-N JUNCTION DIODE CHARACTERISTICS

- AIM:** 1. To observe and draw the Forward and Reverse bias V-I Characteristics of a P-N Junction diode.
2. To calculate static and dynamic resistance in both forward and Reverse Bias Condition.

APPARATUS:

- | | |
|-----------------------------------|--------|
| 1. P-N Diode IN4007 | - 1No. |
| 2. Regulated Power supply (0-30V) | - 1No. |
| 3. Resistor $1K\Omega$ | - 1No. |
| 4. Ammeter (0-20 mA) | - 1No. |
| 5. Ammeter (0-200 μ A) | - 1No. |
| 6. Voltmeter (0-20V) | - 2No. |
| 7. Bread board | |
| 8. Connecting wires | |

THEORY:

A P-N junction diode conducts only in one direction. The V-I characteristics of the diode are curve between voltage across the diode and current flowing through the diode. When external voltage is zero, circuit is open and the potential barrier does not allow the current to flow. Therefore, the circuit current is zero. When P-type (Anode) is connected to +ve terminal and n- type (cathode) is connected to -ve terminal of the supply voltage is known as forward bias. The potential barrier is reduced when diode is in the forward biased condition. At some forward voltage, the potential barrier altogether eliminated and current starts flowing through the diode and also in the circuit. Then diode is said to be in ON state. The current increases with increasing forward voltage.

When N-type (cathode) is connected to +ve terminal and P-type (Anode) is connected -ve terminal of the supply voltage is known as reverse bias and the potential barrier across the junction increases. Therefore, the junction resistance becomes very high and a very small current (reverse saturation current) flows in the circuit. Then diode is said to be in OFF state. The reverse bias current is due to minority charge carriers.

CIRCUIT DIAGRAM:

A) Forward bias:

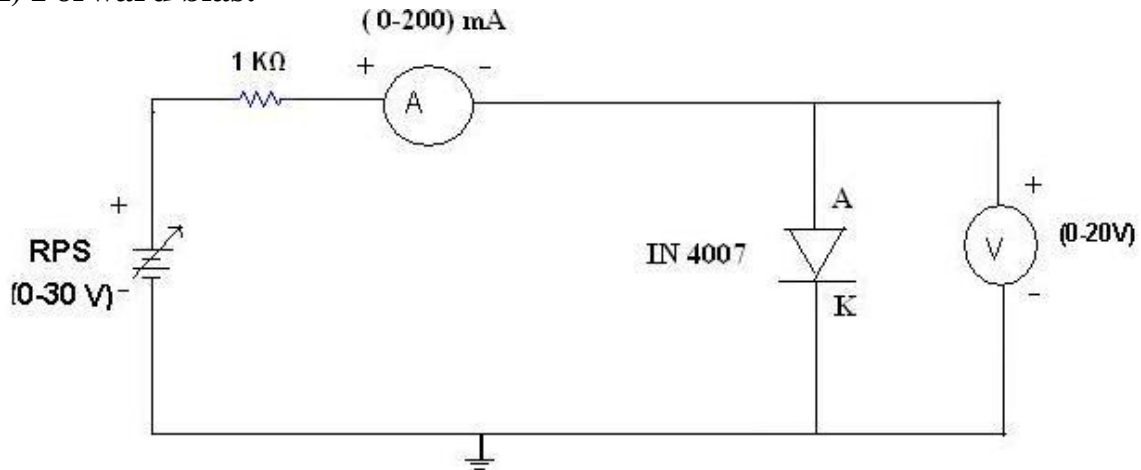

B) Reverse Bias:

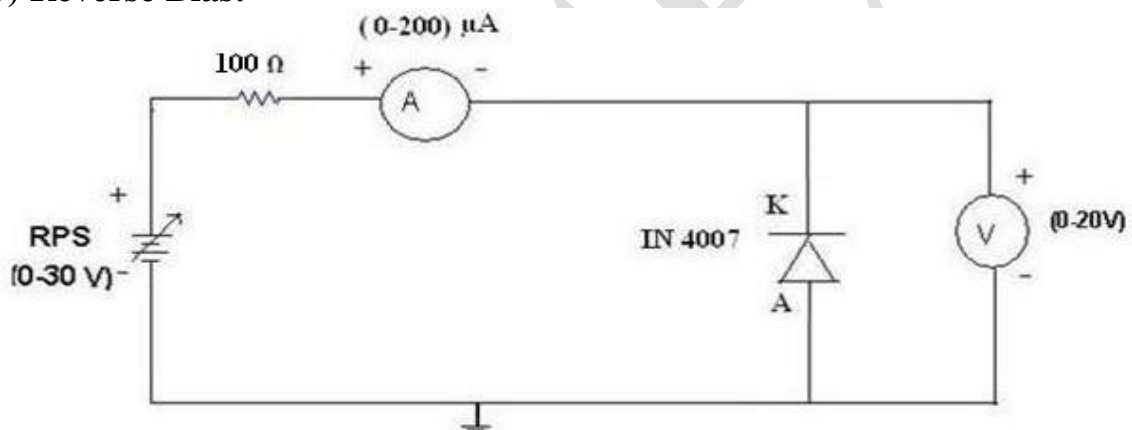

MODEL GRAPH:

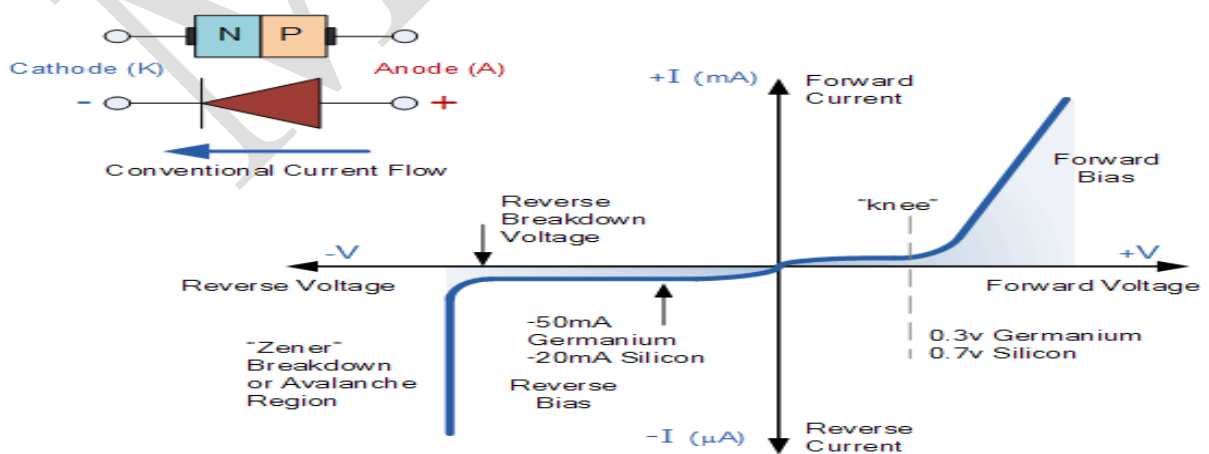

OBSERVATIONS:**A) FORWARD BIAS:**

S.NO	Applied Voltage(V)	Forward Voltage(V _f)	Forward Current(I _f (mA))

B) REVERSE BIAS:

S.NO	Applied Voltage(V)	Reverse Voltage(V _R)	Reverse Current(I _R (μA))

Calculations:

Calculation of Static and Dynamic Resistance for a given diode.

In forward bias condition:

$$\begin{aligned} \text{Static Resistance } R_s &= V_f/I_f = \\ \text{Dynamic Resistance, } R_D &= \Delta V_f/\Delta I_f = \end{aligned}$$

In Reverse bias condition:

$$\begin{aligned} \text{Static Resistance } R_s &= V_R/I_R = \\ \text{Dynamic Resistance, } R_D &= \Delta V_R/\Delta I_R = \end{aligned}$$

PROCEDURE:**A) FORWARD BIAS:**

1. Connections are made as per the circuit diagram.
2. For forward bias, the RPS +ve is connected to the anode of the diode and RPS -ve is connected to the cathode of the diode.
3. Switch on the power supply and increase the input voltage (supply voltage) in steps of 0.1V.
4. Note down the corresponding current flowing through the diode and voltage across the diode for each and every step of the input voltage.
5. The readings of voltage and current are tabulated.
6. Graph is plotted between voltage (V_f) on X-axis and current (I_f) on Y-axis.

B) REVERSE BIAS:

1. Connections are made as per the circuit diagram.
2. For reverse bias, the RPS +ve is connected to the cathode of the diode and RPS -ve is connected to the anode of the diode.
3. Switch on the power supply and increase the input voltage (supply voltage) in steps of 1V.
4. Note down the corresponding current flowing through the diode voltage across the diode for each and every step of the input voltage.
5. The readings of voltage and current are tabulated.
6. Graph is plotted between voltage (V_R) on X-axis and current (I_R) on Y-axis.

PRECAUTIONS:

1. All the connections should be correct.
2. Parallax error should be avoided while taking the readings from the Analog meters.

RESULT:**VIVA QUESTIONS:**

1. Define depletion region of a diode?
2. What is meant by transition & space charge capacitance of a diode?
3. Is the V-I relationship of a diode Linear or Exponential?
4. Define cut-in voltage of a diode and specify the values for Si and Ge diodes?
5. What are the applications of a p-n diode?
6. Draw the ideal characteristics of P-N junction diode?
7. What is the diode equation?
8. What is PIV?
9. What is the break down voltage?
10. What is the effect of temperature on PN junction diodes?
11. Specifications of diodes

2. ZENER DIODE CHARACTERISTICS AND ZENER AS VOLTAGE REGULATOR

AIM:

- a) To observe and draw the static characteristics of a zener diode
- b) To find the voltage regulation of a given zener diode

APPARATUS:

- | | |
|-----------------------------------|--------|
| 1. Zener diode | - 1No. |
| 2. Regulated Power Supply (0-30v) | - 1No. |
| 3. Voltmeter (0-20v) | - 1No. |
| 4. Ammeter (0-20mA) | - 1No. |
| 5. Resistor (1K ohm) | |
| 6. Bread Board | |
| 7. Connecting wires | |

THEORY:

A zener diode is heavily doped p-n junction diode, specially made to operate in the break down region. A p-n junction diode normally does not conduct when reverse biased. But if the reverse bias is increased, at a particular voltage it starts conducting heavily. This voltage is called Break down Voltage. High current through the diode can permanently damage the device.

To avoid high current, we connect a resistor in series with zener diode. Once the diode starts conducting it maintains almost constant voltage across the terminals whatever may be the current through it, i.e., it has very low dynamic resistance. It is used in voltage regulators.

CIRCUIT DIAGRAM

A) STATIC CHARACTERISTICS :

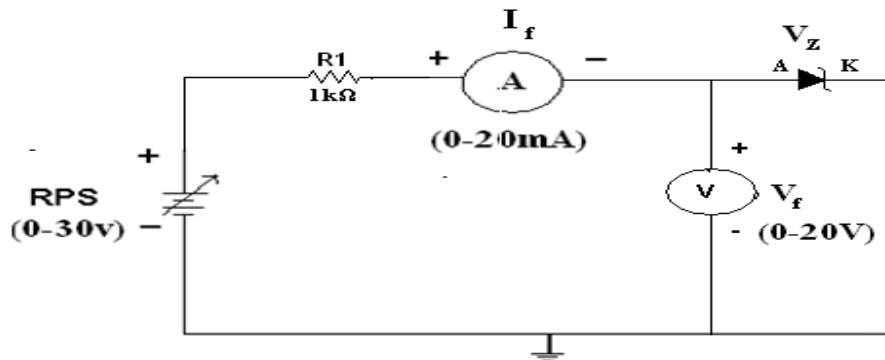

b) REVERSE BIAS CHARACTERISTICS:

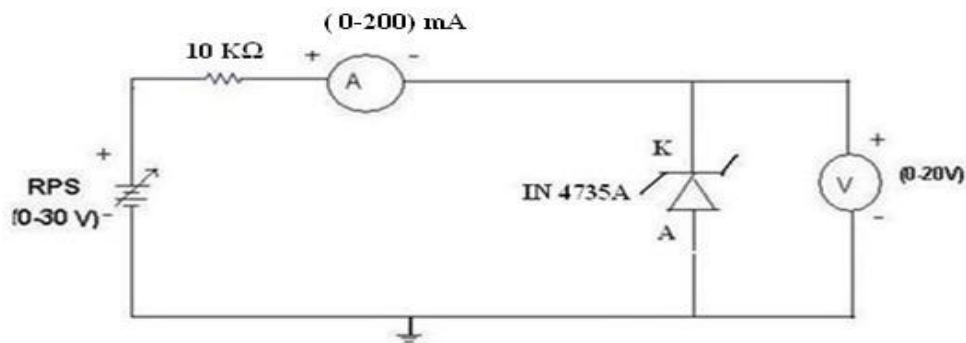

VOLTAGE REGULATION:

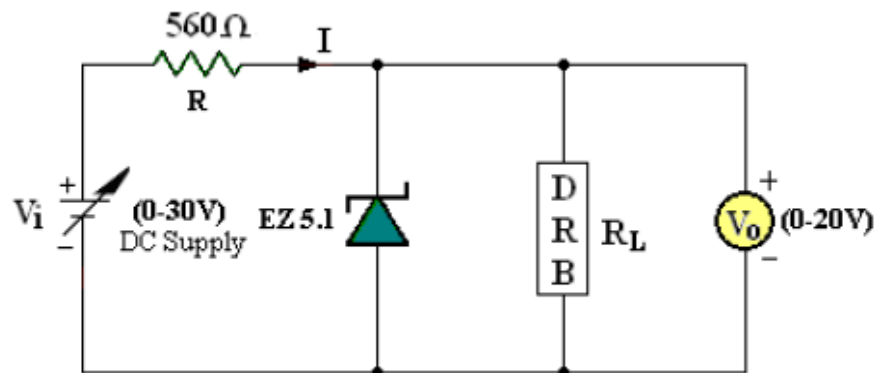

Zener Diode Voltage Regulation

MODEL GRAPHS:

ZENER DIODE CHARACTERISTICS:

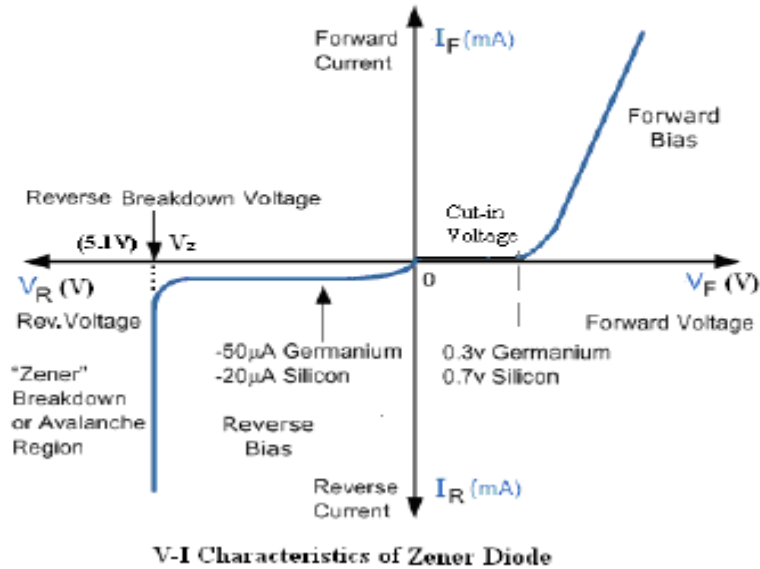

OBSERVATIONS:

A) FORWARD BIAS Characteristics:

S.NO	Applied Voltage(V)	Forward Voltage(V_f)	Forward Current(I_f (mA))

B) REVERSE BIAS Characteristics:

S.NO	Applied Voltage(V)	Reverse Voltage(V_R)	Reverse Current(I_R (mA))

PROCEDURE:**A) Static characteristics:**

1. Connections are made as per the circuit diagram.
2. The Regulated power supply voltage is increased in steps.
3. The Forward current (I_f), and the forward voltage (V_f) are observed and then noted in the tabular form.
4. A graph is plotted between Forward current (I_f) on X-axis and the forward voltage (V_f) on Y-axis.

B) Load Regulation characteristics:

1. Connect the Circuit as per the Circuit Diagram on the bread board.
2. By changing the load Resistance, kept constant I/P Voltage at 5V, 10 V, 15 V as per table given below. Take the readings of O/P Voltmeter ($V_o=V_z$).
3. Now by changing the I/P Voltage, kept constant load Resistance at 1K, 2K, 3K as per table given below. Take the readings of O/P Voltmeter ($V_o=V_z$).

LOAD REGULATION

S.No	R_L (Ω)	$V_{i1}=5V$ V_o (V)	$V_{i2}=10V$ V_o (V)	$V_{i3}=15V$ V_o (V)
1	100			
2	300			
3	500			
4	700			
5	900			
6	1K			
7	3K			
8	5K			
9	7K			
10	10K			

LINE REGULATION

V_i (V)	$R_{L1}=1K\Omega$ V_o (V)	$R_{L2}=2K\Omega$ V_o (V)	$R_{L3}=3K\Omega$ V_o (V)
0			
1			
3			
5			
7			
9			
11			
13			
15			
20			

PRECAUTIONS:

1. The terminals of the zener diode should be properly identified
2. While determined the load regulation, load should not be immediately shorted.
3. Should be ensured that the applied voltages & currents do not exceed the ratings of the diode.

RESULT:

VIVA QUESTIONS:

1. What type of temp coefficient does the zener diode have?
2. If the impurity concentration is increased, how the depletion width effected?
3. Does the dynamic impendence of a zener diode vary?
4. Explain briefly about avalanche and zener breakdowns?
5. Draw the zener equivalent circuit?
6. Differentiate between line regulation & load regulation?
7. In which region zener diode can be used as a regulator?
8. How the breakdown voltage of a particular diode can be controlled?
9. What type of temperature coefficient does the Avalanche breakdown has?
10. By what type of charge carriers the current flows in zener and avalanche breakdown diodes?
11. Define zener break down
12. Applications of zener diode
13. Explain how zener diode as voltage regulator
- 14.

3. HALF -WAVE RECTIFIER WITH AND WITHOUT FILTER

AIM: To examine the input and output waveforms of half wave Rectifier and also Calculate its load regulation and ripple factor.

1. With Filter
2. Without Filter

APPARATUS:

Digital Multimeter	- 1No.
Transformer (6V-0-6V)	- 1No.
Diode, 1N4007	- 1No.
Capacitor 100 μ f/470 μ f	- 1No.
Decade Resistance Box	- 1No.
Breadboard	
CRO and CRO probes	
Connecting wires	

THEORY:

In Half Wave Rectification, When AC supply is applied at the input, only Positive Half Cycle appears across the load whereas, the negative Half Cycle is suppressed. How this can be explained as follows:

During positive half-cycle of the input voltage, the diode D1 is in forward bias and conducts through the load resistor R_L . Hence the current produces an output voltage across the load resistor R_L , which has the same shape as the +ve half cycle of the input voltage.

During the negative half-cycle of the input voltage, the diode is reverse biased and there is no current through the circuit. i.e., the voltage across R_L is zero. The net result is that only the +ve half cycle of the input voltage appears across the load. The average value of the half wave rectified o/p voltage is the value measured on dc voltmeter.

For practical circuits, transformer coupling is usually provided for two reasons.

1. The voltage can be stepped-up or stepped-down, as needed.
2. The ac source is electrically isolated from the rectifier. Thus preventing shock hazards in the secondary circuit.

The efficiency of the Half Wave Rectifier is 40.6%

Theoretical calculations for Ripple factor:**Without Filter:**

$$V_{rms} = V_m/2$$

$$V_m = 2V_{rms}$$

$$V_{dc} = V_m/\pi$$

$$\text{Ripple factor } r = \sqrt{(V_{rms}/V_{dc})^2 - 1} = 1.21$$

With Filter:

$$\text{Ripple factor, } r = 1/(2\sqrt{3} f C R)$$

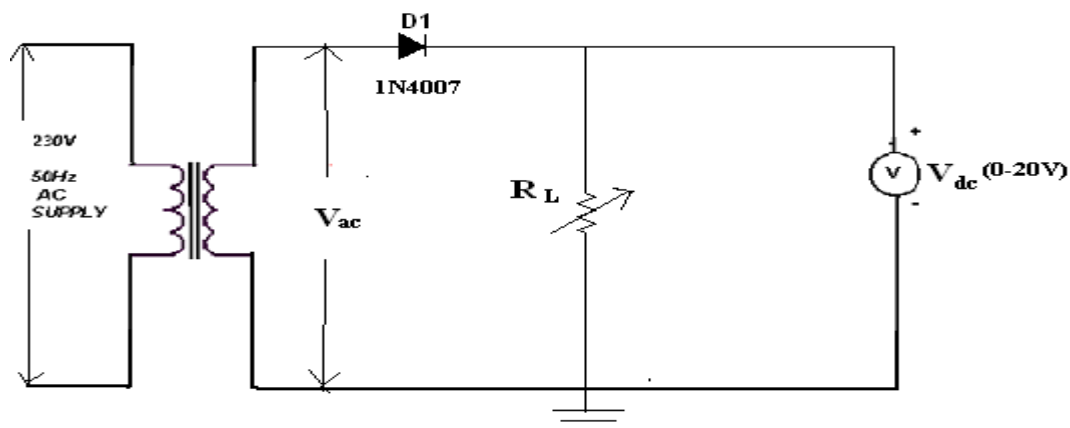
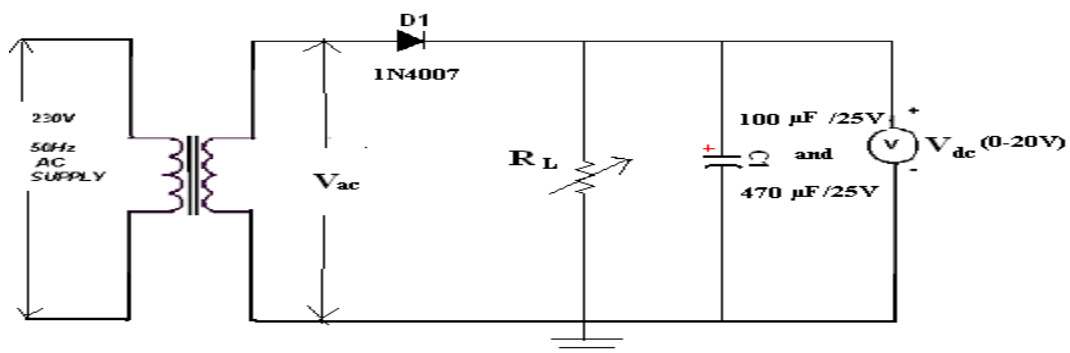
CIRCUIT DIAGRAM:**A) Half Wave Rectifier Without Filter:****B) Half Wave Rectifier With Filter**

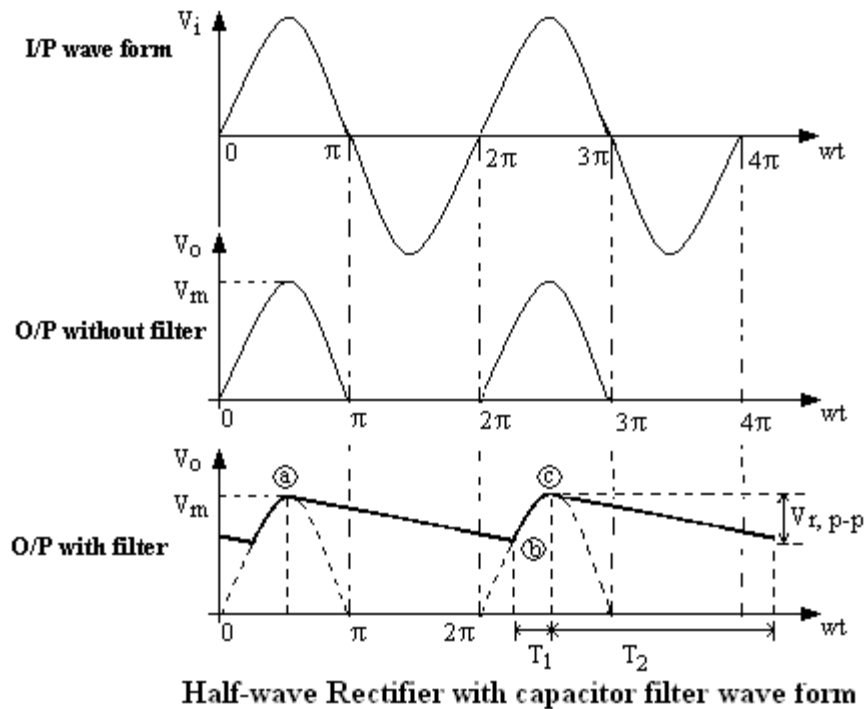
MODEL WAVEFORMS:**A WAVEFORMS:****PROCEDURE:**

1. Connections are made as per the circuit diagram.
2. Connect the primary side of the transformer to ac mains and the secondary side to the rectifier input.
3. By the multimeter, measure the ac input voltage of the rectifier and, ac and dc voltage at the output of the rectifier.
4. Find the theoretical value of dc voltage by using the formula,

$$V_{dc} = V_m / \pi$$
 Where, $V_m = 2V_{rms}$, (V_{rms} = output ac voltage.)
5. The Ripple factor is calculated by using the formula

$$r = \text{ac output voltage} / \text{dc output voltage.}$$

WITHOUT FILTER:

V no load Voltage (Vdc) = V

S.No	Load Resistance R_L kilo-ohm S	O/P Voltage (Vo)		Ripple factor $\left(\gamma = \frac{V_{ac}}{V_{dc}}\right)$	% of Regulation $\left(\frac{V_{NL} - V_{FL}}{V_{NL}} * 100\%\right)$
		V_{ac} (V)	V_{dc} (V)		
1	1				
2	2				
3	3				
4	4				
5	5				
6	6				
7	7				
8	8				

WITH CAPACITOR FILTER:

V no load Voltage (Vdc) = V

S.No	Load Resistance R_L kilo-ohm S	O/P Voltage (Vo)		Ripple factor $\left(\gamma = \frac{V_{ac}}{V_{dc}}\right)$	% of Regulation $\left(\frac{V_{NL} - V_{FL}}{V_{NL}} * 100\%\right)$
		V_{ac} (V)	V_{dc} (V)		
1	1				
2	2				
3	3				
4	4				
5	5				
6	6				
7	7				
8	8				

REGULATION CHARACTERISTICS:

1. Connections are made as per the circuit diagram.
2. By increasing the value of the rheostat, the voltage across the load and current flowing through the load are measured.
3. The reading is tabulated.
4. From the value of no-load voltages, the %regulation is calculated using the formula,

$$\% \text{Regulation} = [(V_{NL} - V_{FL}) / V_{FL}] * 100$$

PRECAUTIONS:

1. The primary and secondary side of the transformer should be carefully identified
2. The polarities of all the diodes should be carefully identified.
3. While determining the % regulation, first full load should be applied and then it should be decremented in steps

RESULT:**VIVA QUESTIONS:**

1. What is the PIV of Half wave rectifier?
2. What is the efficiency of half wave rectifier?
3. What is the rectifier?
4. What is the difference between the half wave rectifier and Full Wave Rectifier?
5. What is the o/p frequency of Bridge Rectifier?
6. What are the ripples?
7. What is the function of the filters?
8. What is TUF?
9. What is the average value of o/p voltage for HWR?
10. What is the peak factor?

4. FULL-WAVE RECTIFIER WITH AND WITHOUT FILTER

AIM: To Examine the input and output waveforms of Full Wave Rectifier and also calculate its load regulation and ripple factor.

1. With Filter
2. Without Filter

APPARATUS:

Digital multimetersMultimeter	- 1No.
Transformer (6V-0-6V)	- 1No.
Diode, 1N4007	- 2No.
Capacitor 100µf/470 µf	- 1No.
Decade Resistance Box	- 1No.
Breadboard	
CRO and CRO probes	
Connecting wires	

THEORY:

The circuit of a center-tapped full wave rectifier uses two diodes D1&D2. During positive half cycle of secondary voltage (input voltage), the diode D1 is forward biased and D2 is reverse biased. So the diode D1 conducts and current flows through load resistor R_L .

During negative half cycle, diode D2 becomes forward biased and D1 reverse biased. Now, D2 conducts and current flows through the load resistor R_L in the same direction. There is a continuous current flow through the load resistor R_L , during both the half cycles and will get unidirectional current as show in the model graph. The difference between full wave and half wave rectification is that a full wave rectifier allows unidirectional (one way) current to the load during the entire 360 degrees of the input signal and half-wave rectifier allows this only during one half cycle (180 degree).

THEORITICAL CALCULATIONS:

$$V_{rms} = V_m / \sqrt{2}$$

$$V_m = V_{rms} \sqrt{2}$$

$$V_{dc} = 2V_m / \pi$$

(i) Without filter:

$$\text{Ripple factor, } r = \sqrt{(V_{rms} / V_{dc})^2 - 1} = 0.812$$

(ii) With filter:

$$\text{Ripple factor, } r = 1 / (4\sqrt{3} f C R_L)$$

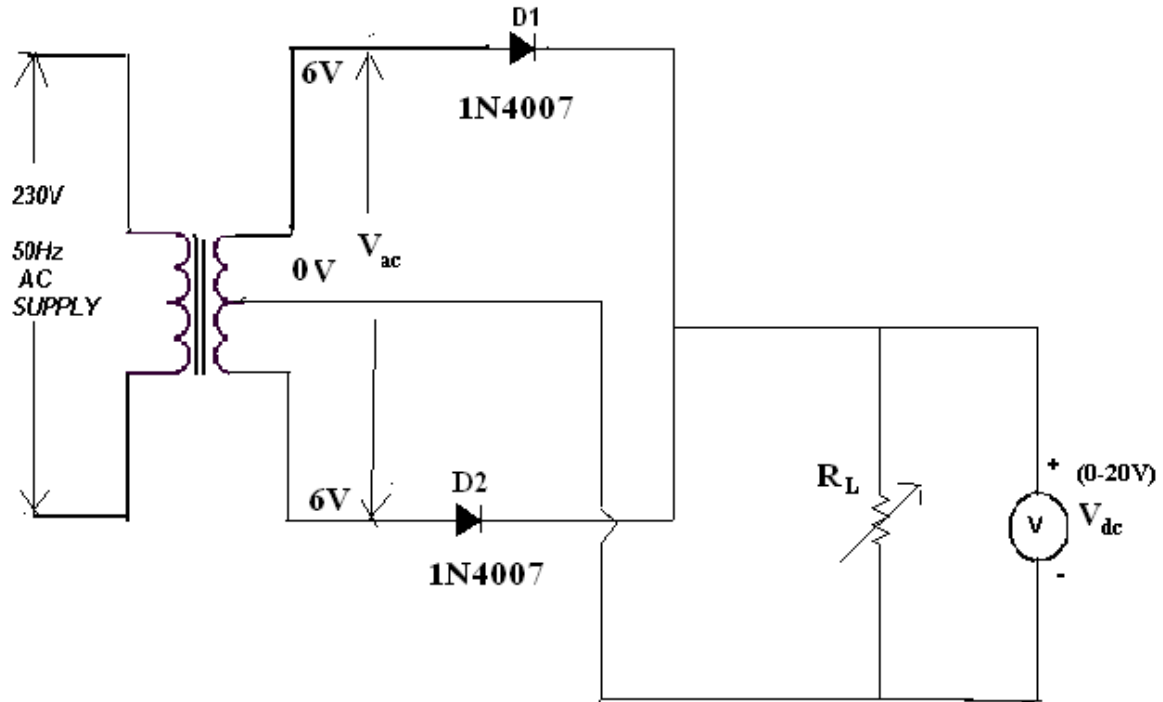
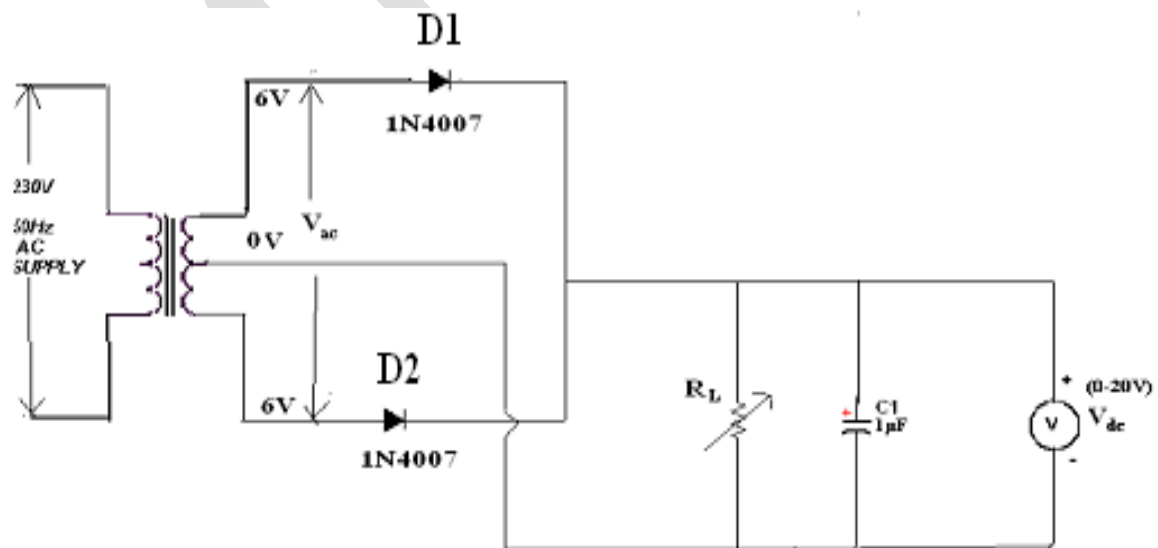
CIRCUIT DIAGRAM:**A) FULL WAVE RECTIFIER WITHOUT FILTER:****B) FULL WAVE RECTIFIER WITH FILTER:**

MODEL WAVEFORMS:

A) WAVEFORMS:

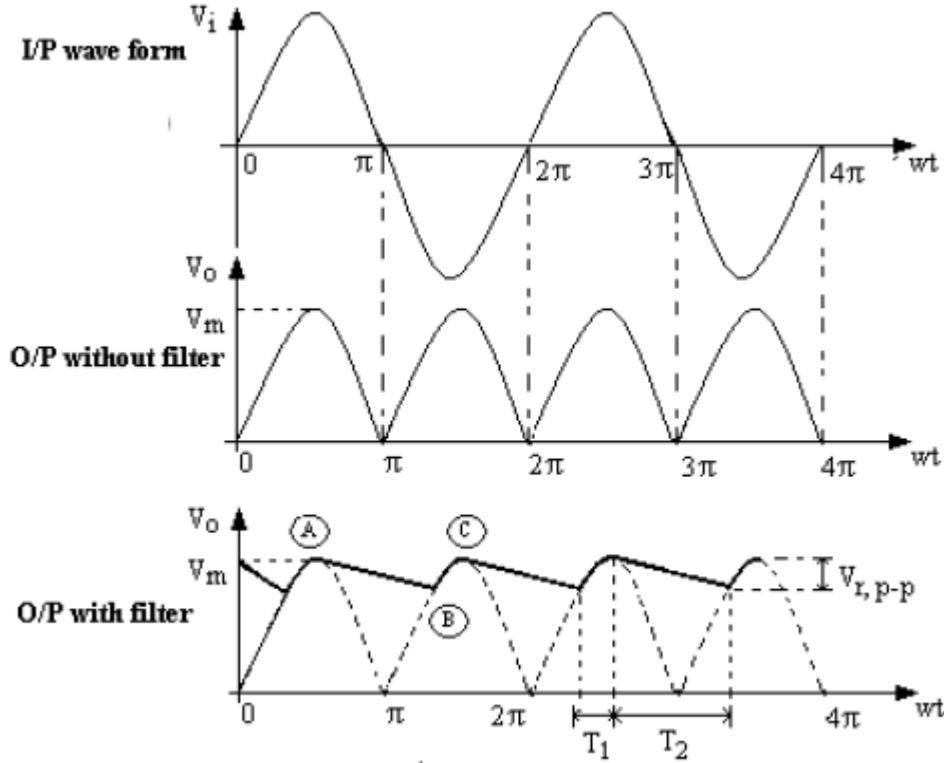

Full-wave Rectifier with capacitor filter wave form

MVA

WITHOUT FILTER:

V no load Voltage (Vdc) = V

S.No	Load Resistance R_L kilo-ohm S	O/P Voltage (Vo)		Ripple factor $\left(\gamma = \frac{V_{ac}}{V_{dc}}\right)$	% of Regulation $\left(\frac{V_{NL} - V_{FL}}{V_{NL}} * 100\%\right)$
		V _{ac} (V)	V _{dc} (V)		
1	1				
2	2				
3	3				
4	4				
5	5				
6	6				
7	7				
8	8				

WITH CAPACITOR FILTER:

V no load Voltage (Vdc) = V

S.No	Load Resistance R_L kilo-ohm S	O/P Voltage (Vo)		Ripple factor $\left(\gamma = \frac{V_{ac}}{V_{dc}}\right)$	% of Regulation $\left(\frac{V_{NL} - V_{FL}}{V_{NL}} * 100\%\right)$
		V _{ac} (V)	V _{dc} (V)		
1	1				
2	2				
3	3				
4	4				
5	5				
6	6				
7	7				
8	8				

PROCEDURE:

1. Connections are made as per the circuit diagram.
2. Connect the ac mains to the primary side of the transformer and the secondary side to the rectifier.
3. Measure the ac voltage at the input side of the rectifier.
4. Measure both ac and dc voltages at the output side the rectifier.
5. Find the theoretical value of the dc voltage by using the formula $V_{dc} = 2V_m/\pi$
6. Connect the filter capacitor across the load resistor and measure the values of V_{ac} and V_{dc} at the output.

7. The theoretical values of Ripple factors with and without capacitor are calculated.
8. From the values of V_{ac} and V_{dc} practical values of Ripple factors are calculated. The practical values are compared with theoretical values.

PRECAUTIONS:

1. The primary and secondary side of the transformer should be carefully identified.
2. The polarities of all the diodes should be carefully identified.

RESULT:**VIVA QUESTIONS:**

1. Define regulation of the full wave rectifier?
2. Define peak inverse voltage (PIV)? And write its value for Full-wave rectifier?
3. If one of the diode is changed in its polarities what wave form would you get?
4. Does the process of rectification alter the frequency of the waveform?
5. What is ripple factor of the Full-wave rectifier?
6. What is the necessity of the transformer in the rectifier circuit?
7. What are the applications of a rectifier?
8. What is meant by ripple and define Ripple factor?
9. Explain how capacitor helps to improve the ripple factor?
10. Can a rectifier made in INDIA ($V=230v$, $f=50Hz$) be used in USA ($V=110v$, $f=60Hz$)?

5. INPUT AND OUTPUT CHARACTERISTICS OF TRANSISTOR CB CONFIGURATION

- AIM:** 1.To observe and draw the input and output characteristics of a transistor connected in common base configuration.
2.To find α of the given transistor and also its input and output Resistances.

APPARATUS:

Transistor, BC107	-1No.
Regulated power supply (0-30V)	-1No.
Voltmeter (0-20V)	- 2No.
Ammeters (0-10mA)	- 2No.
Resistor, 1K Ω	- 2No
Bread board	
Connecting wires	

THEORY:

A transistor is a three terminal active device. The terminals are emitter, base, collector. In CB configuration, the base is common to both input (emitter) and output (collector). For normal operation, the E-B junction is forward biased and C-B junction is reverse biased. In CB configuration, I_E is +ve, I_C is -ve and I_B is -ve. So,

$$V_{EB} = F_1 (V_{CB}, I_E) \text{ and}$$

$$I_C = F_2 (V_{EB}, I_B)$$

With an increasing the reverse collector voltage, the space-charge width at the output junction increases and the effective base width 'W' decreases. This phenomenon is known as "Early effect". Then, there will be less chance for recombination within the base region. With increase of charge gradient with in the base region, the current of minority carriers injected across the emitter junction increases.

The current amplification factor of CB configuration is given by,

$$\alpha = \Delta I_C / \Delta I_E$$

$$\text{Input Resistance, } r_i = \Delta V_{BE} / \Delta I_E \quad \text{at Constant } V_{CB}$$

$$\text{Output Resistance, } r_o = \Delta V_{CB} / \Delta I_C \quad \text{at Constant } I_E$$

CIRCUIT DIAGRAM:

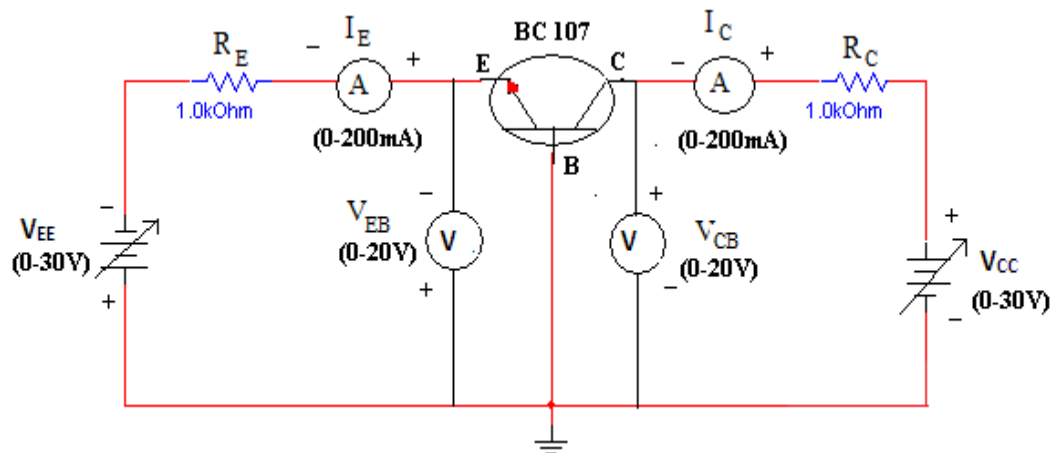

MODEL GRAPHS:

A) INPUT CHARACTERISTICS

Input Characteristics

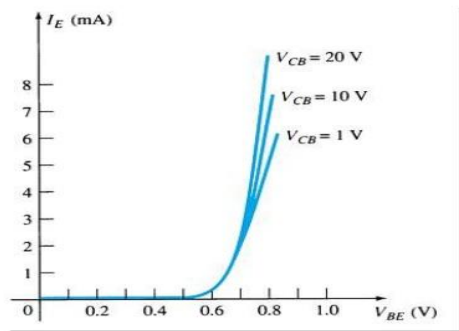

B) OUTPUT CHARACTERISTICS

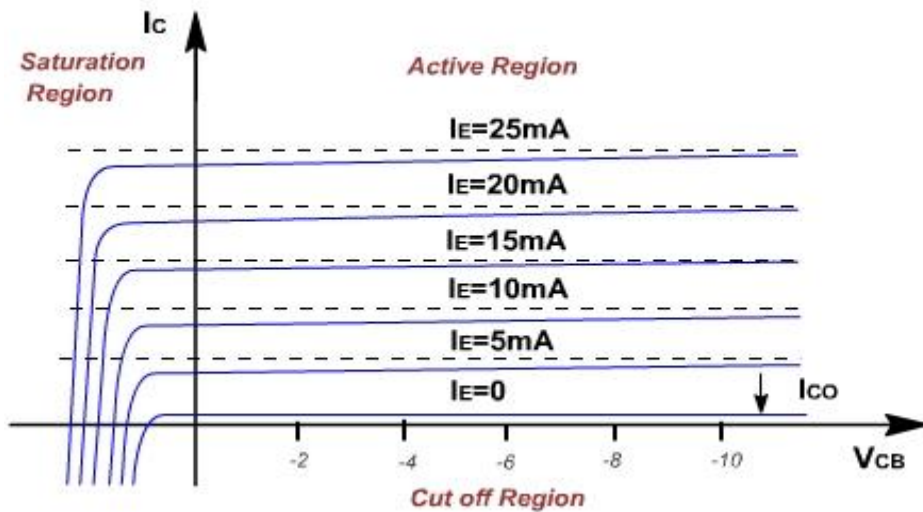

OBSERVATIONS:**A) INPUT CHARACTERISTICS:**

$V_{EE}(V)$	$V_{CB}=1V$		$V_{CB}= 2V$		$V_{CB}= 4V$	
	$V_{EB}(V)$	$I_E(mA)$	$V_{EB}(V)$	$I_E(mA)$	$V_{EB}(V)$	$I_E(mA)$

B) OUTPUT CHARACTERISTICS:

$V_{CC}(V)$	$I_E=10mA$		$I_E=20mA$		$I_E=30mA$	
	$V_{CB}(V)$	$I_C(mA)$	$V_{CB}(V)$	$I_C(mA)$	$V_{CB}(V)$	$I_C(mA)$

PROCEDURE:**A) INPUT CHARACTERISTICS:**

1. Connections are made as per the circuit diagram.
2. For plotting the input characteristics, the output voltage V_{CE} is kept constant at 0V and for different values of V_{EE} note down the values of I_E and V_{BE}
3. Repeat the above step keeping V_{CB} at 2V,4V, and 6V and all the readings are tabulated.
4. A graph is drawn between V_{EB} and I_E for constant V_{CB} .

B) OUTPUT CHARACTERISTICS:

1. Connections are made as per the circuit diagram.
2. For plotting the output characteristics, the input I_E is kept constant at 0.5mA and for different values of V_{CC} , note down the values of I_C and V_{CB} .
3. Repeat the above step for the values of I_E at 1mA, 5mA and all the readings are tabulated.
4. A graph is drawn between V_{CB} and I_C for constant I_E

PRECAUTIONS:

1. The supply voltages should not exceed the rating of the transistor.
2. Meters should be connected properly according to their polarities.

RESULT:**VIVA QUESTIONS:**

1. What is the range of α for the transistor?
2. Draw the input and output characteristics of the transistor in CB configuration?
3. Identify various regions in output characteristics?
4. What is the relation between α and β ?
5. What are the applications of CB configuration?
6. What are the input and output impedances of CB configuration?
7. Define α (alpha)?
8. What is early effect?
9. Draw Circuit diagram of CB configuration for PNP transistor?
10. What is the power gain of CB configuration?

6. INPUT AND OUTPUT CHARACTERISTICS OF TRANSISTOR CE CONFIGURATION

AIM:

1. To draw the input and output characteristics of transistor connected in CE configuration
2. To find β of the given transistor and also its input and output Resistances

APPARATUS:

Transistor, BC107	-1No.
Regulated power supply (0-30V)	-1No.
Voltmeter (0-20V)	- 2No.
Ammeters (0-20mA)	-1No.
Ammeters (0-200 μ A)	-1No.
Resistor, 100 Ω	-1No.
Resistor, 1K Ω	-1No.
Bread board	
Connecting wires	

THEORY:

In common emitter configuration, input voltage is applied between base and emitter terminals and output is taken across the collector and emitter terminals. Therefore the emitter terminal is common to both input and output.

The input characteristics resemble that of a forward biased diode curve. This is expected since the Base-Emitter junction of the transistor is forward biased. As compared to CB arrangement I_B increases less rapidly with V_{BE} . Therefore input resistance of CE circuit is higher than that of CB circuit.

The output characteristics are drawn between I_C and V_{CE} at constant I_B the collector current varies with V_{CE} up to few volts only. After this the collector current becomes almost constant, and independent of V_{CE} . The value of V_{CE} up to which the collector current changes with V_{CE} is known as Knee voltage. The transistor always operated in the region above Knee voltage, I_C is always constant and is approximately equal to I_B . The current amplification factor of CE configuration is given by

$$\beta = \Delta I_C / \Delta I_B$$

Input Resistance, r_i	= $\Delta V_{BE} / \Delta I_B$ (μ A)	at Constant V_{CE}
Output Resistance, r_o	= $\Delta V_{CE} / \Delta I_C$	at Constant I_B (μ A)

CIRCUIT DIAGRAM:

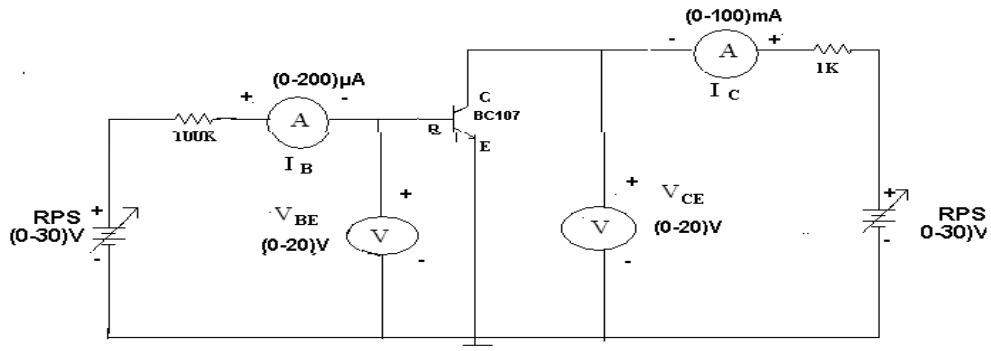

MODEL GRAPHS:

A) INPUT CHARACTERISTICS:

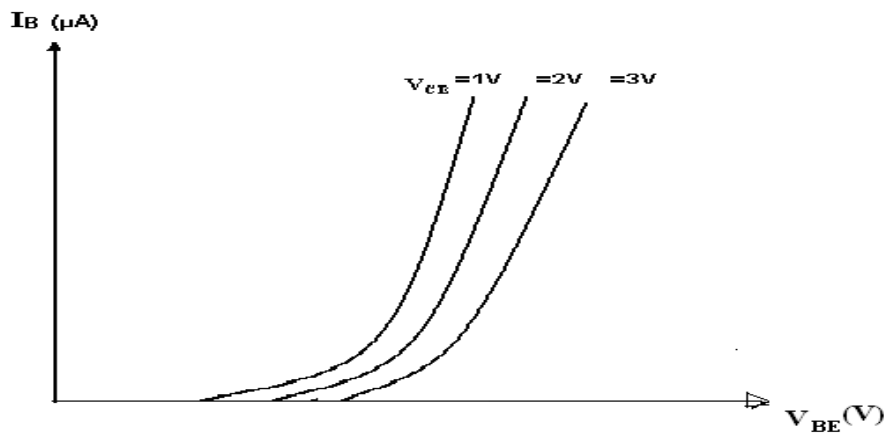

B) OUTPUT CHARACTERISTICS:

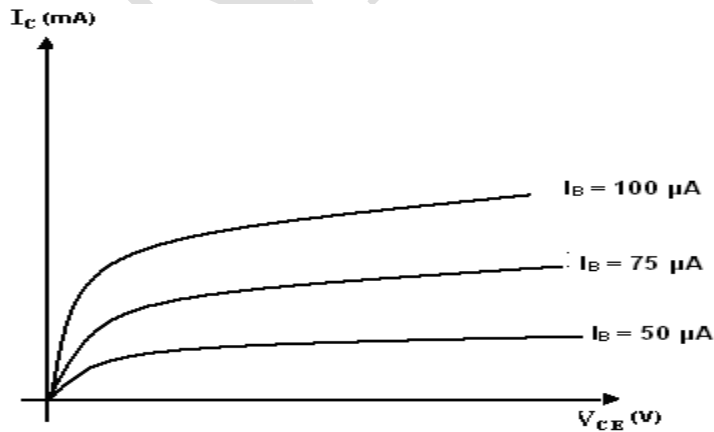

OBSERVATIONS:**A) INPUT CHARACTERISTICS:**

V_{BB}	$V_{CE} = 1V$		$V_{CE} = 2V$		$V_{CE} = 4V$	
	$V_{BE}(V)$	$I_B(\mu A)$	$V_{BE}(V)$	$I_B(\mu A)$	$V_{BE}(V)$	$I_B(\mu A)$

B) OUTPUT CHARACTERISTICS:

S.NO	$I_B = 50 \mu A$		$I_B = 75 \mu A$		$I_B = 100 \mu A$	
	$V_{CE}(V)$	$I_C(mA)$	$V_{CE}(V)$	$I_C(mA)$	$V_{CE}(V)$	$I_C(mA)$

PROCEDURE:**A) INPUT CHARACTERISTICS:**

1. Connect the circuit as per the circuit diagram.
2. For plotting the input characteristics the output voltage V_{CE} is kept constant at 1V and for different values of V_{BB} , note down the values of I_B and V_{BE}
3. Repeat the above step by keeping V_{CE} at 2V and 4V and tabulate all the readings.
4. plot the graph between V_{BE} and I_B for constant V_{CE}

B) OUTPUT CHARACTERISTICS:

1. Connect the circuit as per the circuit diagram
2. for plotting the output characteristics the input current I_B is kept constant at $50\mu\text{A}$ and for different values of V_{CC} note down the values of I_C and V_{CE}
3. Repeat the above step by keeping I_B at $75\mu\text{A}$ and $100\mu\text{A}$ and tabulate the all the readings
4. plot the graph between V_{CE} and I_C for constant I_B

PRECAUTIONS:

1. The supply voltage should not exceed the rating of the transistor
2. Meters should be connected properly according to their polarities

RESULT:**VIVA QUESTIONS:**

1. What is the range of β for the transistor?
2. What are the input and output impedances of CE configuration?
3. Identify various regions in the output characteristics?
4. What is the relation between α and β ?
5. Define current gain in CE configuration?
6. Why CE configuration is preferred for amplification?
7. What is the phase relation between input and output?
8. Draw diagram of CE configuration for PNP transistor?
9. What is the power gain of CE configuration?
10. What are the applications of CE configuration?

7. FET CHARACTERISTICS

AIM:

- To draw the drain and transfer characteristics of a given FET.
- To find the drain resistance (r_d) amplification factor (μ) and TransConductance (g_m) of the given FET.

APPARATUS:

FET BFW11	-1No.
Regulated power supply (0-30V)	-1No.
Voltmeter (0-20V)	-2No.
Ammeter (0-20mA)	-1No.
Bread board	
Connecting wires	

THEORY:

A FET is a three terminal device, in which current conduction is by majority carriers only. The flow of current is controlled by means of an Electric field. The three terminals of FET are Gate, Drain and Source. It is having the characteristics of high input impedance and less noise, the Gate to Source junction of the FETs always reverse biased. In response to small applied voltage from drain to source, the n-type bar acts as sample resistor, and the drain current increases linearly with V_{DS} . With increase in I_D the ohmic voltage drop between the source and the channel region reverse biases the junction and the conducting position of the channel begins to remain constant. The V_{DS} at this instant is called "pinch of voltage". If the gate to source voltage (V_{GS}) is applied in the direction to provide additional reverse bias, the pinch off voltage will be decreased. In amplifier application, the FET is always used in the region beyond the pinch-off.

FET parameters:

AC Drain Resistance, $r_d = \Delta V_{DS} / \Delta I_D$ at constant V_{GS}

Trans conductance, $g_m = \Delta I_D / \Delta V_{GS}$ at constant V_{DS}

Amplification, $\mu = \Delta V_{DS} / \Delta V_{GS}$ at constant I_D

Relation between above parameters

$$\mu = r_d * g_m$$

The drain current is given by

$$I_D = I_{DSS} (1 - V_{GS}/V_P)^2$$

CIRCUIT DIAGRAM:

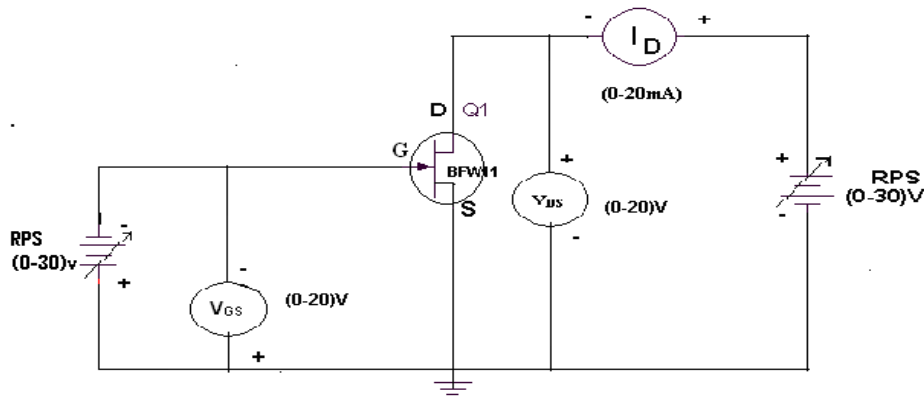

MODEL GRAPH:

A) DRAIN CHARACTERISTICS:

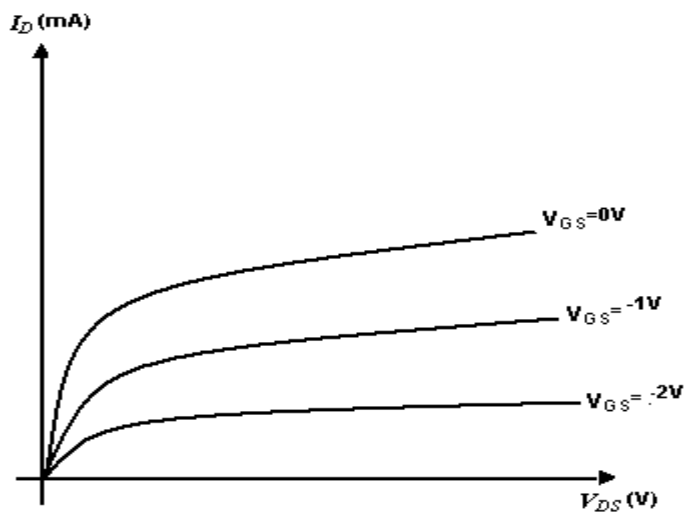

B) TRANSFER CHARACTERISTICS:

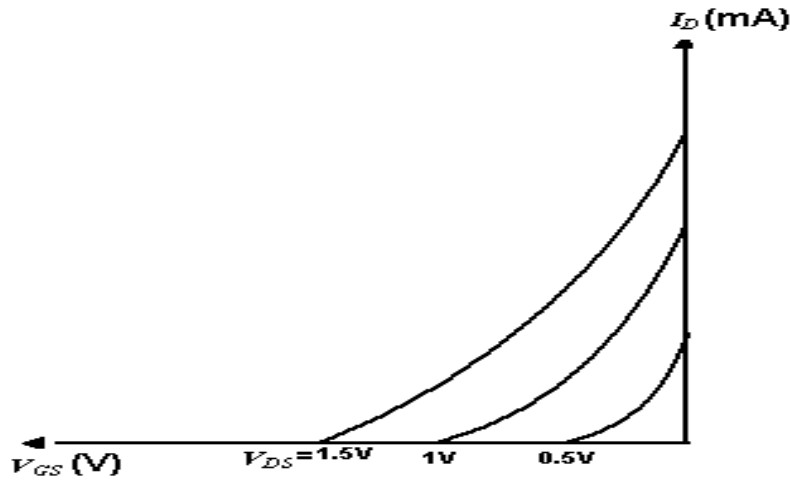

OBSERVATIONS:

A) DRAIN CHARACTERISTICS:

S.NO	$V_{GS} = 0V$		$V_{GS} = 0.1V$		$V_{GS} = 0.2V$	
	$V_{DS}(V)$	$I_D(mA)$	$V_{DS}(V)$	$I_D(mA)$	$V_{DS}(V)$	$I_D(mA)$

B) TRANSFER CHARACTERISTICS:

S.NO	$V_{DS} = 0.5V$		$V_{DS} = 1V$		$V_{DS} = 1.5V$	
	$V_{GS}(V)$	$I_D(mA)$	$V_{GS}(V)$	$I_D(mA)$	$V_{GS}(V)$	$I_D(mA)$

PROCEDURE:

1. All the connections are made as per the circuit diagram.
2. To plot the drain characteristics, keep V_{GS} constant at 0V.
3. Vary the V_{DD} and observe the values of V_{DS} and I_D .
4. Repeat the above steps 2, 3 for different values of V_{GS} at 0.1V and 0.2V.
5. All the readings are tabulated.
6. To plot the transfer characteristics, keep V_{DS} constant at 1V.
7. Vary V_{GG} and observe the values of V_{GS} and I_D .
8. Repeat steps 6 and 7 for different values of V_{DS} at 1.5 V and 2V.
9. The readings are tabulated.
10. From drain characteristics, calculate the values of dynamic resistance (r_d)
11. From transfer characteristics, calculate the value of transconductance (g_m)
12. And also calculate Amplification factor (μ).

PRECAUTIONS:

1. The three terminals of the FET must be carefully identified
2. Practically FET contains four terminals, which are called source, drain, Gate, substrate.
3. Source and case should be short circuited.
4. Voltages exceeding the ratings of the FET should not be applied.

RESULT:**VIVA QUESTIONS:**

1. What are the advantages of FET?
2. Different between FET and BJT?
3. Explain different regions of V-I characteristics of FET?
4. What are the applications of FET?
5. What are the types of FET?
6. Draw the symbol of FET?
7. What are the disadvantages of FET?
8. What are the parameters of FET?

8. h- PARAMETERS OF CB CONFIGURATION

AIM: To calculate the h-parameters of transistor in CB configuration.

APPARATUS:

S.No.	Name	Quantity
1	Transistor BC 107	1(One) No.
2	Resistors ($1K\Omega$)	2(Two) No.
3	Bread board	1(One) No.

Equipment:

S.No.	Name	Quantity
1	Dual DC Regulated Power supply (0 – 30 V)	1(One) No.
2	Digital Ammeters (0 – 200 mA)	2(Two) No.
3	Digital Voltmeter (0-20V)	2(Two) No.
4	Connecting wires (Single Strand)	2

Circuit Diagram:

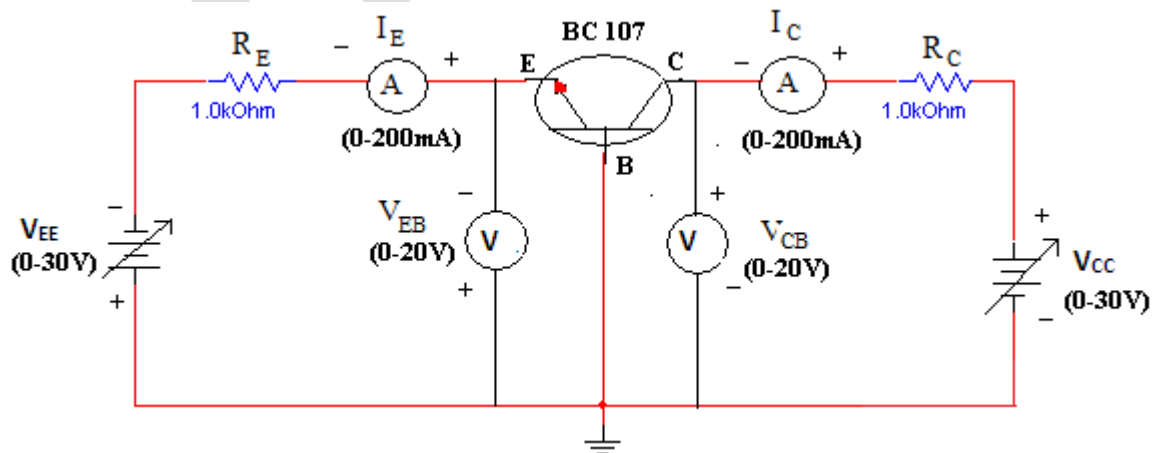

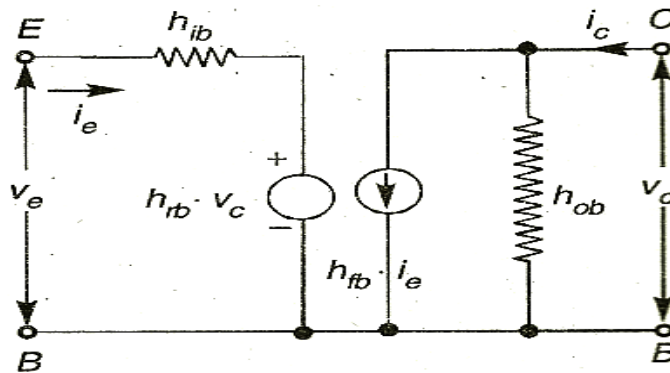
h – Parameter model of CB transistor:**Procedure:****Input Characteristics:**

1. Connect the circuit as shown in the circuit diagram.
2. Keep output voltage $V_{CB} = 0V$ by varying V_{CC} .
3. Varying V_{EE} gradually, note down emitter current I_E and emitter-base voltage (V_{EE}).
4. Step size is not fixed because of nonlinear curve. Initially vary V_{EE} in steps of 0.1 V. Once the current starts increasing vary V_{EE} in steps of 1V up to 12V.
5. Repeat above procedure (step 3) for $V_{CB} = 4V$.

Output Characteristics:

1. Connect the circuit as shown in the circuit diagram.
2. Keep emitter current $I_E = 5mA$ by varying V_{EE} .
3. Varying V_{CC} gradually in steps of 1V up to 12V and note down collector current I_C and collector-base voltage (V_{CB}).
4. Repeat above procedure (step 3) for $I_E = 10mA$.

Repeat above procedure (step 3) for $I_E = 10mA$.

Observations:

Input Characteristics				
V_{EE} (Volts)	$V_{CB} = 0V$		$V_{CB} = 4V$	
	V_{EB} (Volts)	I_E (mA)	V_{EB} (Volts)	I_E (mA)

Output Characteristics						
V_{CC} (Volts)	$I_E = 0\text{mA}$		$I_E = 5\text{V}$		$I_E = 10\text{mA}$	
	V_{CB} (Volts)	I_C (mA)	V_{CB} (Volts)	I_C (mA)	V_{CB} (Volts)	I_C (mA)

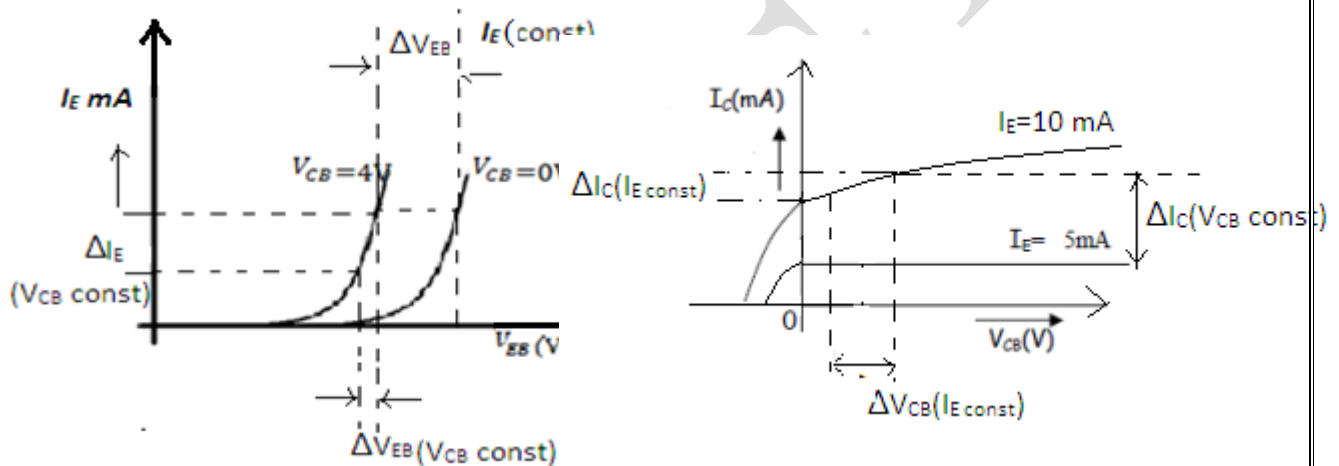
Graph:

1. Plot the input characteristics for different values of V_{CB} by taking V_{BE} on X-axis and I_E on Y-axis taking V_{CB} as constant parameter.
2. Plot the output characteristics by taking V_{CB} on X-axis and taking I_C on Y-axis taking I_E as a constant parameter.

Calculations from Graph:

The h-parameters are to be calculated from the following formulae:

1. **Input Characteristics:** To obtain input resistance, find ΔV_{BE} and ΔI_E for a constant V_{CB} on one of the input characteristics.

$$\text{Input impedance} = h_{ib} = R_i = \Delta V_{BE} / \Delta I_E \quad (V_{CB} = \text{constant})$$

$$\text{Reverse voltage gain} = h_{rb} = \Delta V_{EB} / \Delta V_{CB} \quad (I_E = \text{constant})$$

2. **Output Characteristics:** To obtain output resistance, find ΔI_C and ΔV_{CB} at a constant I_E .

$$\text{Output admittance} = h_{ob} = 1/R_o = \Delta I_C / \Delta V_{CB} \quad (I_E = \text{constant})$$

$$\text{Forward current gain} = h_{fb} = \Delta I_C / \Delta I_E \quad (V_{CB} = \text{constant})$$

Result:

The h-parameters for a transistor in CB configuration are:

- a. The Input resistance (h_{ib}) _____ Ohms.
 b. The Reverse Voltage Transfer Ratio (h_{rb}) _____.
 c. The Output Admittance (h_{ob}) _____ Mhos.
 d. The Forward Current gain (h_{fb}) _____.

Discussion/Viva Questions:

1. What is transistor?
2. Write the relation between α and β ?
3. Define α (alpha)? What is the range of α ?
4. Why α is less than unity?
5. Input and output impedance equations for CB configuration?
6. What is carrier lifetime?
7. What is the importance of Fermi level?
8. Can the junction less transistors be realized?
9. What is the doping level of E, B and C layers?
10. List the various current components in BJT.

9. h-PARAMETERS OF CE CONFIGURATION

AIM: To calculate the h-parameters of transistor in CE configuration.

APPARATUS:

Transistor BC107	- 1No.
Resistors 100 K Ω 100 Ω	- 1No.Each
Ammeter (0-200 μ A)	- 1No.
Ammeter(0-200mA)	-1No.
Voltmeter (0-20V)	- 2Nos
Regulated Power Supply (0-30V)	- 2Nos
Breadboard	

THEORY:

A) INPUT CHARACTERISTICS:

The two sets of characteristics are necessary to describe the behaviour of the CE configuration, in which one for input or base emitter circuit and other for the output or collector emitter circuit. In input characteristics the emitter base junction forward biased by a very small voltage V_{BE} where as collector base junction reverse biased by a very large voltage V_{CC} . The input characteristics are a plot of input current I_B Versus, the input voltage V_{BE} for a range of values of output voltage V_{CE} . The following important points can be observed from these characteristics curves.

1. Input resistance is high as I_B increases less rapidly with V_{BE}
2. The input resistance of the transistor is the ratio of change in base emitter voltage ΔV_{BE} to change in base current ΔI_B at constant collector emitter voltage (V_{CE}) i.e...
Input resistance or input impedance $h_{ie} = \Delta V_{BE} / \Delta I_B$ at V_{CE} constant.

B) OUTPUT CHARACTERISTICS:

A set of output characteristics or collector characteristics are a plot of out put current I_C V_S output voltage V_{CE} for a range of values of input current I_B . The following important points can be observed from these characteristics curves.

1. The transistor always operates in the active region. i.e. the collector current I_C increases with V_{CE} very slowly. For low values of the V_{CE} the I_C increases rapidly with a small increase in V_{CE} . The transistor is said to be working in saturation region.

2. Output resistance is the ratio of change of collector emitter voltage ΔV_{CE} , to change in collector current ΔI_C with constant I_B . Output resistance or Output impedance $h_{oe} = \Delta V_{CE} / \Delta I_C$ at I_B constant.

Input Impedance $h_{ie} = \Delta V_{BE} / \Delta I_B$ at V_{CE} constant

Output impedance $h_{oe} = \Delta V_{CE} / \Delta I_C$ at I_B constant

Reverse Transfer Voltage Gain $h_{re} = \Delta V_{BE} / \Delta V_{CE}$ at I_B constant

Forward Transfer Current Gain $h_{fe} = \Delta I_C / \Delta I_B$ at constant V_{CE}

CIRCUIT DIAGRAM:

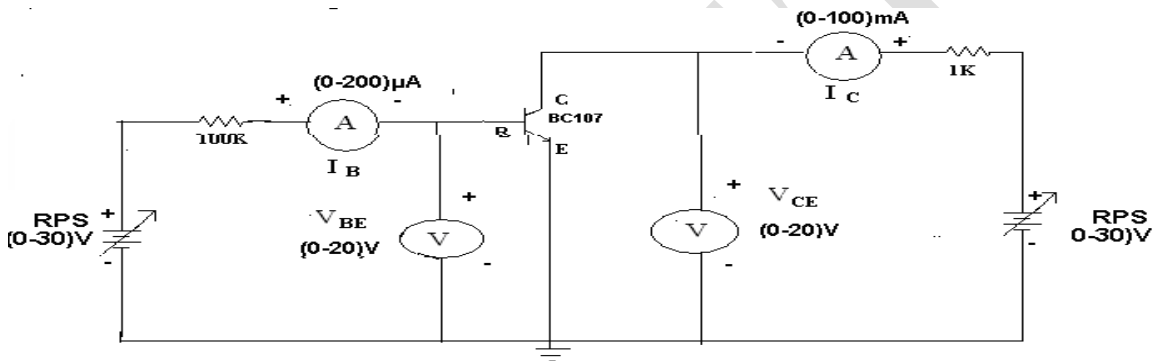

MODEL GRAPH:

A) INPUT CHARACTERISTICS: i) calculation of h_{ie} ii) calculation of h_{re}

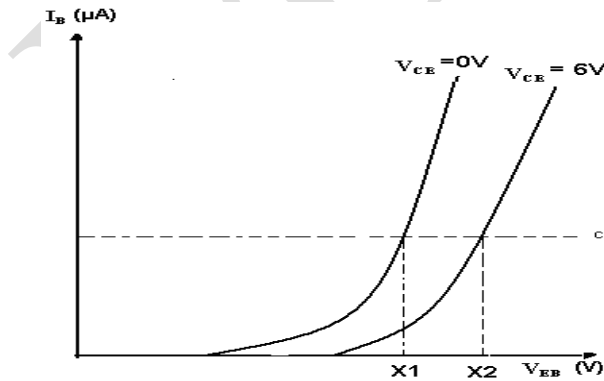

$$h_{re} = \Delta V_{BE} / \Delta V_{CE} \text{ at } I_B \text{ constant}$$

$$= (X_2 - X_1) / (V_{CE} = 6V) - (V_{CE} = 0V)$$

OUTPUT CHARACTERISTICS: i) calculation of h_{fe}

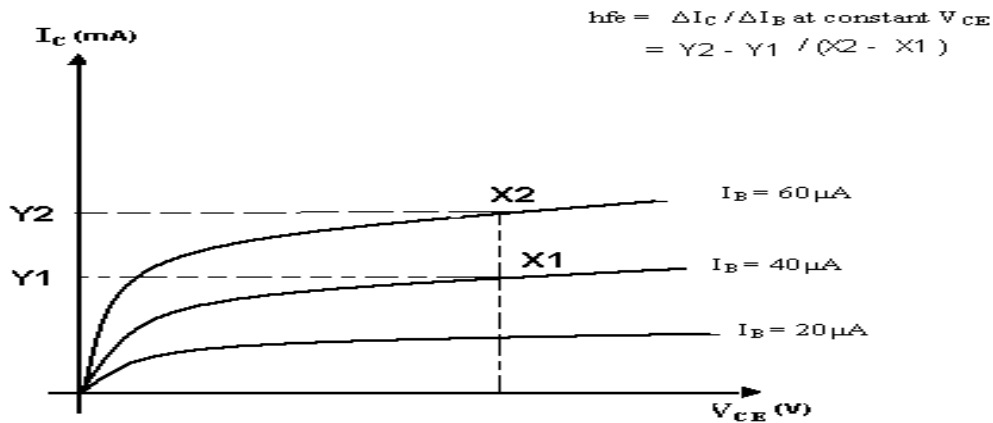

ii) calculation of h_{oe}

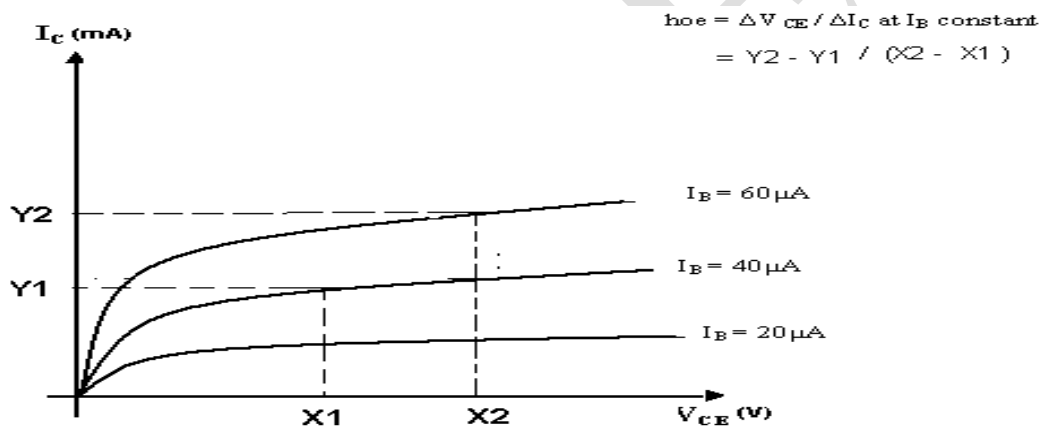

TABULAR FORMS:

A) Input Characteristics:

S.NO	$V_{CE}=0V$		$V_{CE}=6V$	
	$V_{BE}(V)$	$I_B(\mu A)$	$V_{BE}(V)$	$I_B(\mu A)$

B) Output Characteristics:

S.NO	$I_B = 20 \mu A$		$I_B = 40 \mu A$		$I_B = 60 \mu A$	
	V_{CE} (V)	I_C (mA)	V_{CE} (V)	I_C (mA)	V_{CE} (V)	I_C (mA)

PROCEDURE:

1. Connect a transistor in CE configuration circuit for plotting its input and output characteristics.
2. Take a set of readings for the variations in I_B with V_{BE} at different fixed values of output voltage V_{CE} .
3. Plot the input characteristics of CE configuration from the above readings.
4. From the graph calculate the input resistance h_{ie} and reverse transfer ratio h_{re} by taking the slopes of the curves.
5. Take the family of readings for the variations of I_C with V_{CE} at different values of fixed I_B .
6. Plot the output Characteristics from the above readings.
7. From the graphs calculate h_{fe} and h_{oe} by taking the slope of the curves.

RESULT:**VIVA QUESTIONS:**

1. What are the h-parameters?
2. What are the limitations of h-parameters?
3. What are its applications?
4. Draw the Equivalent circuit diagram of H parameters?
5. Define H parameter?
6. What are tabular forms of H parameters monoculture of a transistor?
7. What is the general formula for input impedance?
8. What is the general formula for Current Gain?
9. What is the general formula for Voltage gain?

10. FREQUENCY RESPONSE OF CE AMPLIFIER

AIM:

1. To Measure the voltage gain of a CE amplifier
2. To draw the frequency response curve of the CE amplifier

APPARATUS:

Transistor BC107	-1No.
Regulated power Supply (0-30V)	-1No.
Function Generator	-1No.
CRO	-1No.
Resistors [33K Ω , 3.3K Ω , 330 Ω , 1.5K Ω , 1K Ω , 2.2K Ω , 4.7K Ω]	-1No.Each
Capacitors, 10 μ F	-2No
100 μ F	-1No.
Bread Board	
Connecting Wires	

THEORY:

The CE amplifier provides high gain & wide frequency response. The emitter lead is common to both input & output circuits and is grounded. The emitter-base circuit is forward biased. The collector current is controlled by the base current rather than emitter current. When a transistor is biased in active region it acts like an amplifier. The input signal is applied to base terminal of the transistor and amplifier output is taken across collector terminal. A very small change in base current produces a much larger change in collector current. When positive half-cycle is fed to the input circuit, it opposes the forward bias of the circuit which causes the collector current to decrease; it decreases the voltage more negative. Thus when input cycle varies through a negative half-cycle, increases the forward bias of the circuit, which causes the collector current to increase thus the output signal is common emitter amplifier is in out of phase with the input signal. An amplified output signal is obtained when this fluctuating collector current flows through a collector resistor R_c .

The capacitor across the collector resistor R_c will act as a bypass capacitor. This will improve high frequency response of amplifier.

CIRCUIT DIAGRAM:

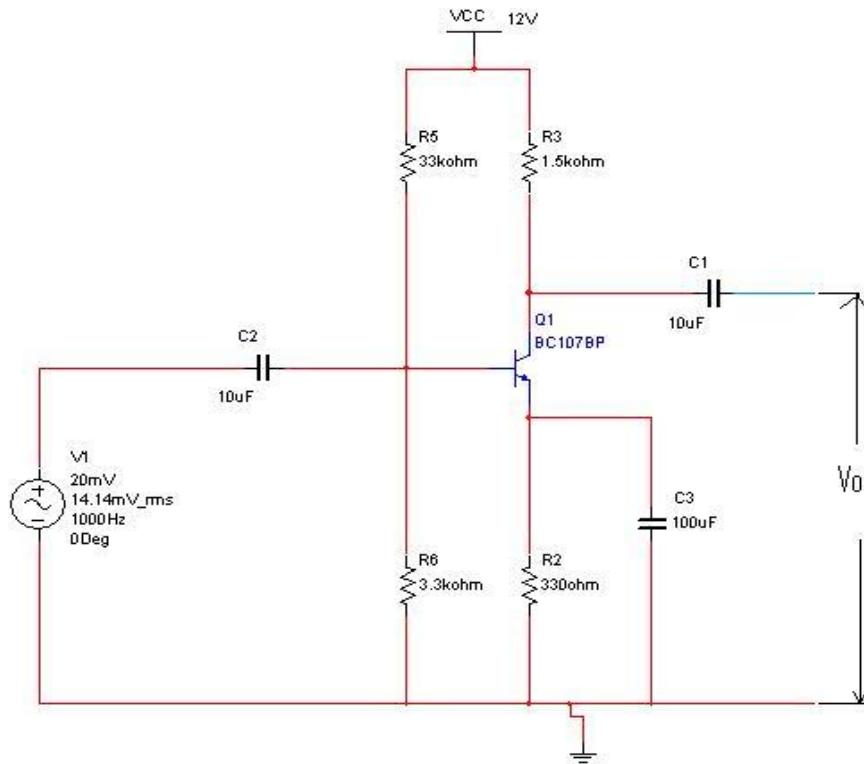

MODELWAVE FORMS:

A) INPUT WAVE FORM:

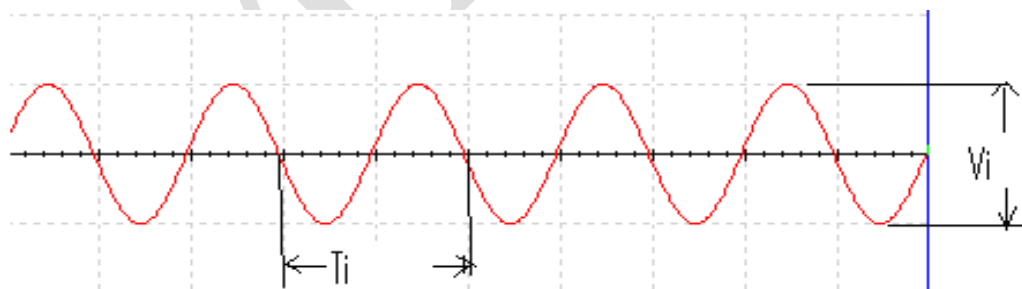

B) OUTPUT WAVE FORM:

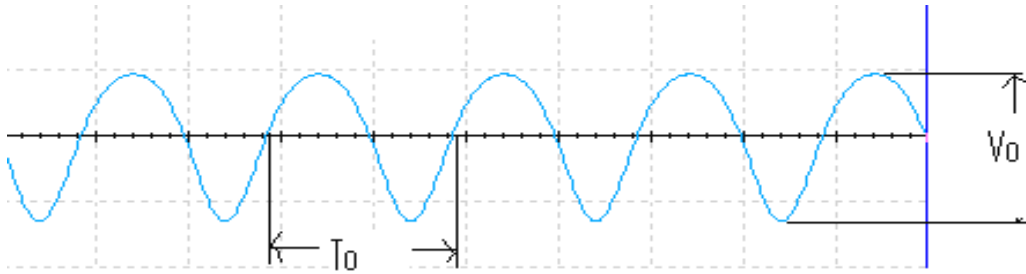

FREQUENCY RESPONSE:

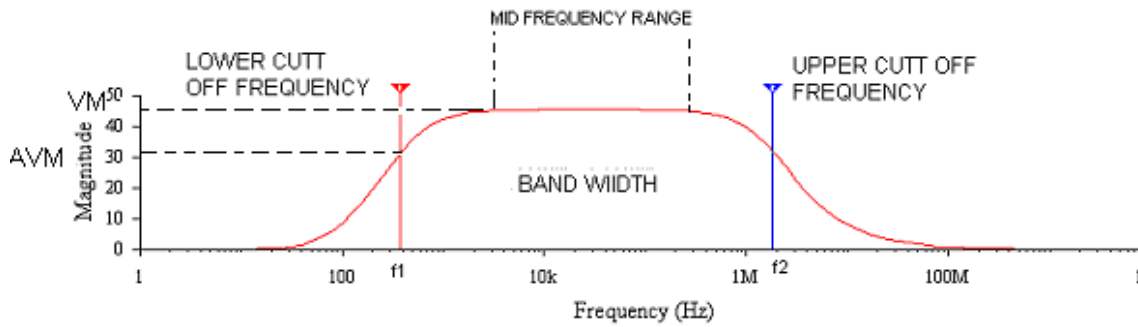

OBSERVATIONS:

FREQUENCY RESPONSE: $V_i = 20\text{mv}$

Frequency in KHZ	OUTPUT VOLTAGE(V_o)	GAIN IN $\text{dB}=20\log_{10}(v_o/v_i)$

PROCEDURE:

1. Connect the circuit as shown in circuit diagram
2. Apply the input of 20mV peak-to-peak and 1 KHz frequency using Function Generator
3. The voltage gain can be calculated by using the expression , $A_v = (V_o/V_i)$
4. For plotting the frequency response the input voltage is kept Constant at 20mV peak-to-peak and the frequency is varied from 100Hz to 1MHz Using function generator
5. Note down the value of output voltage for each frequency.
6. All the readings are tabulated and voltage gain in dB is calculated by Using The expression $A_v = 20 \log_{10} (V_o/V_i)$
7. A graph is drawn by taking frequency on x-axis and gain in dB on y-axis On Semi-log graph.
10. The band width of the amplifier is calculated from the graph using the expression,

$$\text{Bandwidth, BW} = f_2 - f_1$$

Where f_1 lower cut-off frequency of CE amplifier, and

Where f_2 upper cut-off frequency of CE amplifier

11. The bandwidth product of the amplifier is calculated using the Expression

$$\text{Gain Bandwidth product} = 3\text{-dBmidband gain} \times \text{Bandwidth}$$

RESULT:**VIVA QUESTIONS:**

1. What is phase difference between input and output waveforms of CE amplifier?
2. What type of biasing is used in the given circuit?
3. If the given transistor is replaced by a p-n-p, can we get output or not?
4. What is effect of emitter-bypass capacitor on frequency response?
5. What is the effect of coupling capacitor?
6. What is region of the transistor so that it is operated as an amplifier?
7. How does transistor acts as an amplifier?
8. Draw the h-parameter model of CE amplifier?
9. What type of transistor configuration is used in intermediate stages of a multistage amplifier?
10. What is early effect?

11. FREQUENCY RESPONSE OF CC AMPLIFIER

AIM:

1. To measure the voltage gain of a CC amplifier
2. To draw the frequency response of the CC amplifier

APPARATUS:

Transistor BC 107	-1No.
Regulated Power Supply (0-30V)	-1No.
Function Generator	-1No.
CRO	-1No.
Resistors 33K Ω , 3.3K Ω , 330 Ω , 1.5K Ω , 1K Ω , 2.2K Ω & 4.7K Ω	-1No.Each
Capacitors 10 μ F	-2Nos
100 μ F	-1No.
Breadboard	
Connecting wires	

THEORY:

In common-collector amplifier the input is given at the base and the output is taken at the emitter. In this amplifier, there is no phase inversion between input and output. The input impedance of the CC amplifier is very high and output impedance is low. The voltage gain is less than unity. Here the collector is at ac ground and the capacitors used must have a negligible reactance at the frequency of operation.

This amplifier is used for impedance matching and as a buffer amplifier. This circuit is also known as emitter follower.

The most common use of the emitter follower is as a circuit, which performs the function of impedance transformation over a wide range of frequencies.

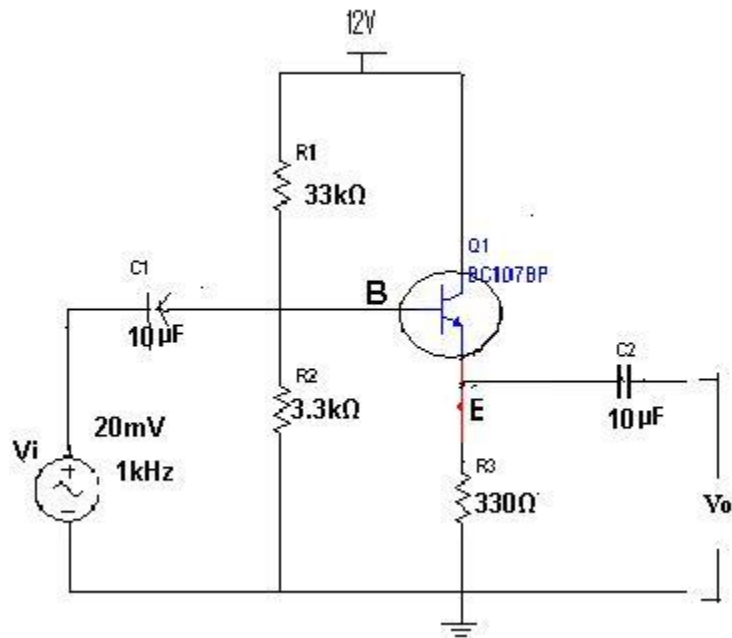
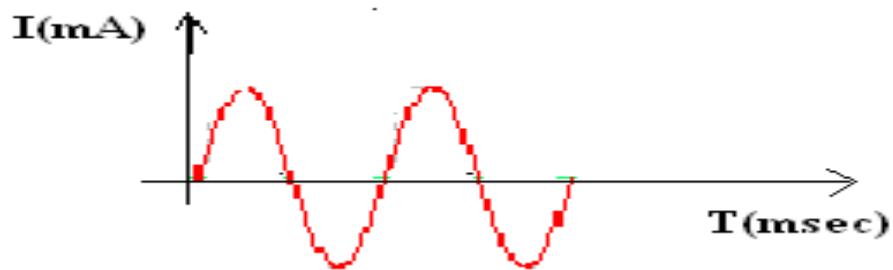
CIRCUIT DIAGRAM:**MODEL WAVEFORM:****A) INPUT WAVEFORM:**

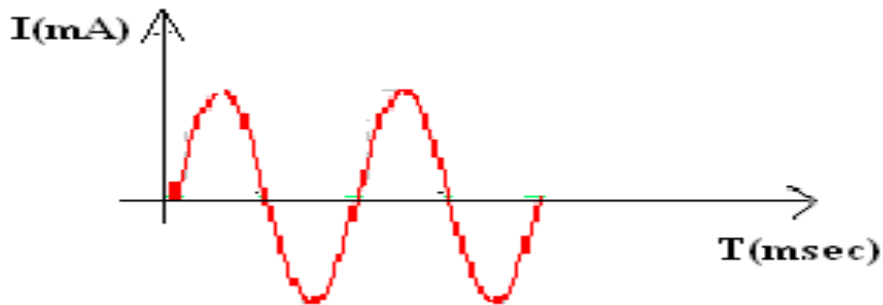
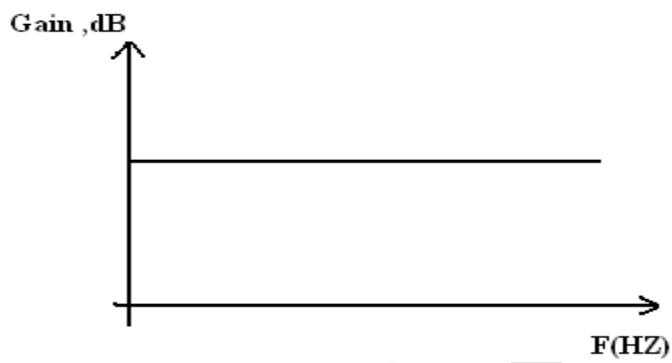
B) OUTPUT WAVEFORM:**FREQUENCY RESPONSE PLOT:****OBSERVATIONS:****A) FREQUENCY RESPONSE, $V_i = 20\text{mV}$**

Frequency(HZ)	Output Voltage(V_o)	Gain in dB $A_v = 20 \log_{10}(V_o/V_i)$

PROCEDURE:

1. Connections are made as per the circuit diagram.
2. The voltage gain calculated by using the expression $A_v = V_o/V_i$
3. For plotting the frequency response the input voltage is kept constant a 20mV peak-to-peak and the frequency is varied from 100Hz to 1MHz.
4. Note down the values of output voltage for each frequency.
5. The voltage gain in dB is calculated by using the expression,

$$A_v = 20 \log_{10}(V_o/V_i)$$
6. A graph is drawn by taking frequency on X-axis and gain in dB on y-axis on semi-log graph sheet.
7. The Bandwidth of the amplifier is calculated from the graph using the Expression,

$$\text{Bandwidth BW} = f_2 - f_1$$

Where f_1 is lower cut-off frequency of CE amplifier
 f_2 is upper cut-off frequency of CE amplifier
8. The gain Bandwidth product of the amplifier is calculated using the Expression,

$$\text{Gain -Bandwidth product} = 3\text{-dB midband gain} \times \text{Bandwidth}$$

PRECAUTIONS:

1. The input voltage must be kept constant while taking frequency response.
2. Proper biasing voltages should be applied.

RESULT:**VIVA QUESTIONS:**

1. What are the applications of CC amplifier?
2. What is the voltage gain of CC amplifier?
3. What are the values of input and output impedances of the CC amplifier?
4. To which ground the collector terminal is connected in the circuit?
5. Identify the type of biasing used in the circuit?
6. Give the relation between α , β and γ .
7. Write the other name of CC amplifier?
8. What are the differences between CE, CB and CC?
9. When compared to CE, CC is not used for amplification. Justify your answer?
10. What is the phase relationship between input and output in CC?

12. FREQUENCY RESPONSE OF COMMON SOURCE FET AMPLIFIER

AIM:

1. To obtain the frequency response of the common source FET Amplifier
2. To find the Bandwidth.

APPARATUS:

N-channel FET (BFW11)	-1No.
Resistors (6.8K Ω , 1M Ω , 1.5K Ω)	-1No.Each
Capacitors 0.1 μ F,	-2Nos
47 μ F	-1No.
Regulated power Supply (0-30V)	-1No.
Function generator	-1No.
CRO	-1No.
CRO probes	-1pair
Bread board	
Connecting wires	

THEORY:

A field-effect transistor (FET) is a type of transistor commonly used for weak-signal amplification (for example, for amplifying wireless (signals). The device can amplify analog or digital signals. It can also switch DC or function as an oscillator. In the FET, current flows along a semiconductor path called the channel. At one end of the channel, there is an electrode called the source. At the other end of the channel, there is an electrode called the drain. The physical diameter of the channel is fixed, but its effective electrical diameter can be varied by the application of a voltage to a control electrode called the gate. Field-effect transistors exist in two major classifications. These are known as the junction FET (JFET) and the metal-oxide- semiconductor FET (MOSFET). The junction FET has a channel consisting of N-type semiconductor (N-channel) or P-type semiconductor (P-channel) material; the gate is made of the opposite semiconductor type. In P-type material, electric charges are carried mainly in the form of electron deficiencies called holes. In N-type material, the charge carriers are primarily electrons. In a JFET, the junction is the boundary between the channel and the gate. Normally, this P-N junction is reverse-biased (a DC voltage is applied to it) so that no current flows between the channel and the gate. However, under some conditions there is a small current through the junction during part of the input signal cycle. The FET has some advantages and some disadvantages relative to the bipolar transistor. Field-effect transistors are preferred for weak-signal work, for example in wireless, communications and broadcast receivers. They are also preferred in circuits and systems

requiring high impedance. The FET is not, in general, used for high-power amplification, such as is required in large wireless communications and broadcast transmitters.

Field-effect transistors are fabricated onto silicon integrated circuit (IC) chips. A single IC can contain many thousands of FETs, along with other components such as resistors, capacitors, and diodes.

A common source amplifier FET amplifier has high input impedance and a moderate voltage gain. Also, the input and output voltages are 180 degrees out of Phase.

CIRCUIT DIAGRAM:

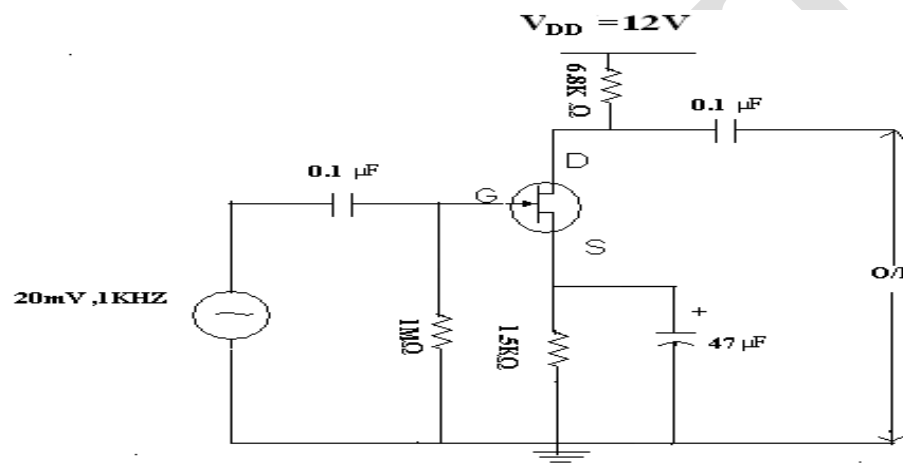

MODEL GRAPH:

A) INPUT WAVEFORM

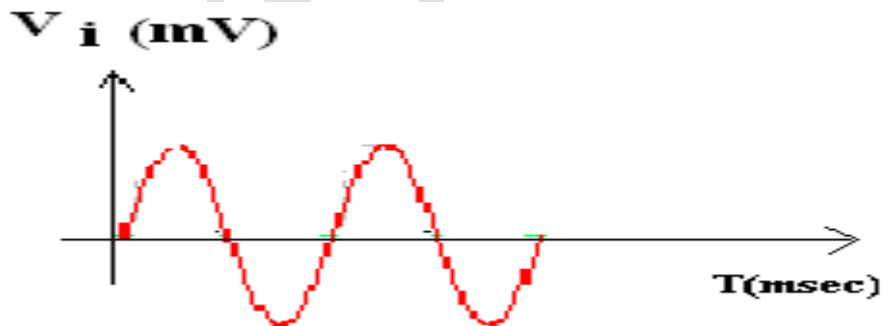

B) OUTPUT WAVEFORM

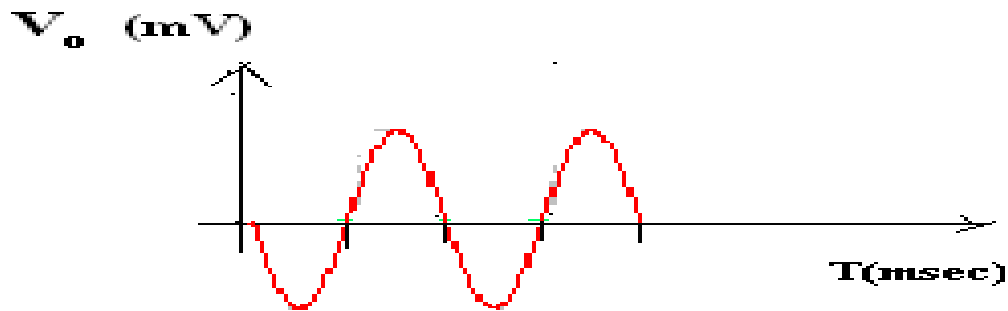

FREQUENCY RESPONSE PLOT:

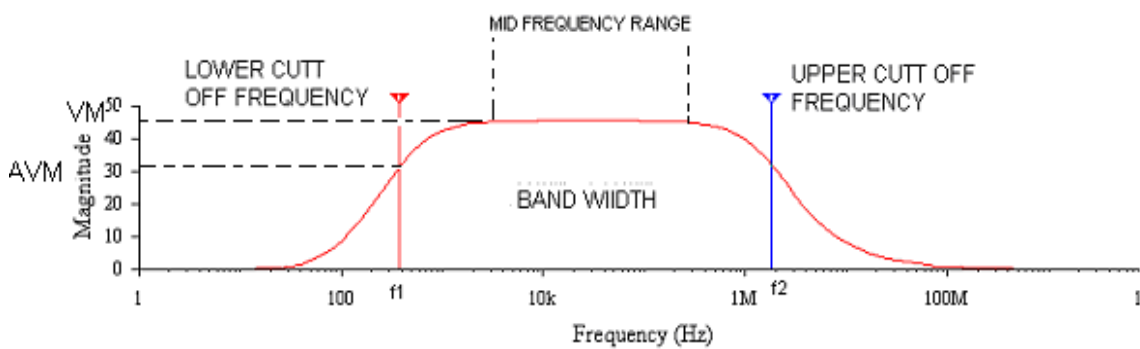

OBSERVATIONS:

INPUT VOLTAGE (V_i) = 20mA

S.NO	Output Voltage(V_o)	Voltage gain= V_o/V_{in}	Gain in $dB=20\log_{10}(V_o/V_{in})$

PROCEDURE:

1. Connections are made as per the circuit diagram.
2. A signal of 1 KHz frequency and 20mV peak-to-peak is applied at the Input of amplifier.
3. Output is taken at drain and gain is calculated by using the expression,
$$A_v = V_0/V_i$$
4. Voltage gain in dB is calculated by using the expression,
$$A_v = 20 \log_{10}(V_0/V_i)$$
5. Repeat the above steps for various input voltages.
6. Plot A_v in dB Versus Frequency
7. The Bandwidth of the amplifier is calculated from the graph using the Expression,

$$\text{Bandwidth BW} = f_2 - f_1$$

Where f_1 is lower 3 dB frequency
 f_2 is upper 3 dB frequency

PRECAUTIONS:

1. All the connections should be tight.
2. Transistor terminals must be identified properly

RESULT:**VIVA QUESTIONS:**

1. What is the difference between FET and BJT?
2. FET is unipolar or bipolar?
3. Draw the symbol of FET?
4. What are the applications of FET?
5. FET is voltage controlled or current controlled?
6. Draw the equivalent circuit of common source FET amplifier?
7. What is the voltage gain of the FET amplifier?
8. What is the input impedance of FET amplifier?
9. What is the output impedance of FET amplifier?
10. What are the FET parameters?
11. What are the FET applications

Answer all the following questions:

1. What is a pn junction? How is it formed? (2M)
2. Sketch the energy-band Diagrams for intrinsic and extrinsic semiconductors (3M)
3. What is meant by rectifier? (2M)
4. Compare the performance measure of different filters. (3M)
5. Why Transistor is called Current Controlled Device? (2M)
6. What is early effect? How does it modify the V-I characteristics of a BJT? (3M)
7. What is meant by operating point? Explain its significance (2M)
8. What is the condition for thermal stability and thermal resistance? (3M)
9. Explain when a FET acts as a voltage variable resistor. (2M)
10. Explain the drain and transfer characteristics of a JFET in details (3M)
11. What do you mean by potential barrier for a p-n junction? (2M)
12. What is the significance of negative resistance of a tunnel diode (3M)
13. Define peak inverse voltage (PIV). (2M)
14. Explain FWR working principle with circuit and waveforms. (3M)
15. What are the three regions of a Transistor? (2M)
16. What is thermal runaway? How can it avoid? (3M)
17. What is faithful amplification? (2M)
18. Derive relation between α , β and γ ? (3M)
19. Define the pinch off voltage (V_p) sketch the depletion region before and after Pinch-off? (2M)
20. Derive Expression for saturation drain current (3M)
21. What is mean by zener breakdown (2M)
22. Explain the effect of temperature on the V-I characteristics of pn junction diode (3M)
23. What is meant by filter in rectifier circuits (2M)
24. Bridge rectifier is becoming more and more popular, why? (3M)
25. Write B.J.T specifications and limitations (2M)
26. Explain how transistor acts as an Amplifier? (3M)
27. What is meant by stabilization (2M)
28. What is thermal runaway? How can it avoid? (3M)
29. State the application of JFET and compare MOSFET (2M)
30. When FET acts as a voltage variable resistor (V.V.R)? (3M)
31. What is diode equation? (2M)
32. Draw the V-I characteristics of SCR & define all related terms. (3M)
33. What is the purpose of bleeder resistance in a rectifier circuit using LC filter? (2M)
34. Write short note on Full wave rectifier (FWR) along with input output waveforms. (3M)
35. Why hybrid parameters are called so? Define those (2M)
36. What factors are to be considered for selecting the operating point Q for an amplifier? (3M)
37. Why does potential divider method of biasing become universal? (2M)
38. Why FET is unipolar and BJT is Bipolar Device (3M)

39. Draw the symbols of JFET (N Channel/P channel) MOSFET (Depletion MOSFET (n-channel/p-channel) and Enhancement MOSFET (n-channel/p-channel) (2M)
40. Draw the low frequency hybrid equivalent circuit for CE, CB and CC (3M)
41. Sketch the V-I characteristics of p-n junction diode for forward bias? (2M)
42. Explain zener diode as a voltage regulator. (3M)
43. Distinguish between the incremental resistance and the apparent resistance of the diode (2M)
44. Derive efficiency of FWR. (3M)
45. In a filter circuit, why capacitor is a parallel combination and series combination for inductor. (2M)
46. Define Transformer Utilization Factor (TUF). (2M)
47. What is transistor? (3M)
48. Draw voltage divider bias circuit; derive an expression for its stability factor.(2M)
49. Explain transfer characteristics of JFET with its non-linear relations (3M)
50. Explain tunneling effect (2M)