



# MALLAREDDY COLLEGE OF ENGINEERING & TECHNOLOGY

(AUTONOMOUS INSTITUTION – UGC, GOVT. OF INDIA)



## Department of AERONAUTICAL ENGINEERING



### ENGINEERING THERMODYNAMICS

Prepared by:

**S. Shailesh Babu**

**Assistant Professor**

**Dept of Aeronautical**

# ENGINEERING THERMODYNAMICS



## DIGITAL NOTES

### B.TECH (R-24 Regulation)

### (II YEAR – I SEM)

(2025 - 26)

## DEPARTMENT AERONAUTICAL ENGINEERING



## MALLA REDDY COLLEGE OF ENGINEERING & TECHNOLOGY

### (Autonomous Institution – UGC, Govt. of India)

Recognized under 2(f) and 12 (B) of UGC ACT 1956

(Affiliated to JNTUH, Hyderabad, Approved by AICTE - Accredited by NBA & NAAC – 'A' Grade - ISO 9001:2015 Certified)  
Maisammaguda, Dhulapally (Post Via. Hakimpet), Secunderabad – 500100, Telangana State, India

## **MRCET VISION**

To establish a pedestal for the integral innovation, team spirit, originality and competence in the students, expose them to face the global challenges and become pioneers of Indian vision of modern society.

## **MRCET MISSION**

- To become a model institution in the fields of Engineering, Technology and Management.
- To impart holistic education to the students to render them as industry ready engineers.
- To ensure synchronization of institute ideologies with challenging demands of International Pioneering Organizations.

## PROGRAM OUTCOMES

(PO's)

**Engineering Graduates will be able to:**

1. **Engineering knowledge:** Apply the knowledge of mathematics, science, engineering fundamentals, and an engineering specialization to the solution of complex engineering problems.
2. **Problem analysis:** Identify, formulate, review research literature, and analyze complex engineering problems reaching substantiated conclusions using first principles of mathematics, natural sciences, and engineering sciences.
3. **Design / development of solutions:** Design solutions for complex engineering problems and design system components or processes that meet the specified needs with appropriate consideration for the public health and safety, and the cultural, societal, and environmental considerations.
4. **Conduct investigations of complex problems:** Use research-based knowledge and research methods including design of experiments, analysis and interpretation of data, and synthesis of the information to provide valid conclusions.
5. **Modern tool usage:** Create, select, and apply appropriate techniques, resources, and modern engineering and IT tools including prediction and modeling to complex engineering activities with an understanding of the limitations.
6. **The engineer and society:** Apply reasoning informed by the contextual knowledge to assess societal, health, safety, legal and cultural issues and the consequent responsibilities relevant to the professional engineering practice.
7. **Environment and sustainability:** Understand the impact of the professional engineering solutions in societal and environmental contexts, and demonstrate the knowledge of, and need for sustainable development.
8. **Ethics:** Apply ethical principles and commit to professional ethics and responsibilities and norms of the engineering practice.
9. **Individual and team work:** Function effectively as an individual, and as a member or leader in diverse teams, and in multidisciplinary settings.

10. **Communication:** Communicate effectively on complex engineering activities with the engineering community and with society at large, such as, being able to comprehend and write effective reports and design documentation, make effective presentations, and give and receive clear instructions.
11. **Project management and finance:** Demonstrate knowledge and understanding of the engineering and management principles and apply these to one's own work, as a member and leader in a team, to manage projects and in multi disciplinary environments.
12. **Life- long learning:** Recognize the need for, and have the preparation and ability to engage in independent and life-long learning in the broadest context of technological change.

## **DEPARTMENT OF AERONAUTICAL ENGINEERING**

### **VISION**

Department of Aeronautical Engineering aims to be indispensable source in Aeronautical Engineering which has a zeal to provide the value driven platform for the students to acquire knowledge and empower themselves to shoulder higher responsibility in building a strong nation.

### **MISSION**

The primary mission of the department is to promote engineering education and research. To strive consistently to provide quality education, keeping in pace with time and technology. Department passions to integrate the intellectual, spiritual, ethical and social development of the students for shaping them into dynamic engineers.

### **QUALITY POLICY STATEMENT**

Impart up-to-date knowledge to the students in Aeronautical area to make them quality engineers. Make the students experience the applications on quality equipment and tools. Provide systems, resources and training opportunities to achieve continuous Improvement. Maintain global standards in education, training and services.

## **PROGRAM EDUCATIONAL OBJECTIVES – Aeronautical Engineering**

1. **PEO1 (PROFESSIONALISM & CITIZENSHIP):** To create and sustain a community of learning in which students acquire knowledge and learn to apply it professionally with due consideration for ethical, ecological and economic issues.
2. **PEO2 (TECHNICAL ACCOMPLISHMENTS):** To provide knowledge based services to satisfy the needs of society and the industry by providing hands on experience in various technologies in core field.
3. **PEO3 (INVENTION, INNOVATION AND CREATIVITY):** To make the students to design, experiment, analyze, and interpret in the core field with the help of other multi disciplinary concepts wherever applicable.
4. **PEO4 (PROFESSIONAL DEVELOPMENT):** To educate the students to disseminate research findings with good soft skills and become a successful entrepreneur.
5. **PEO5 (HUMAN RESOURCE DEVELOPMENT):** To graduate the students in building national capabilities in technology, education and research

## **PROGRAM SPECIFIC OUTCOMES – Aeronautical Engineering**

1. To mould students to become a professional with all necessary skills, personality and sound knowledge in basic and advance technological areas.
2. To promote understanding of concepts and develop ability in design manufacture and maintenance of aircraft, aerospace vehicles and associated equipment and develop application capability of the concepts sciences to engineering design and processes.
3. Understanding the current scenario in the field of aeronautics and acquire ability to apply knowledge of engineering, science and mathematics to design and conduct experiments in the field of Aeronautical Engineering.
4. To develop leadership skills in our students necessary to shape the social, intellectual, business and technical worlds.

# MALLA REDDY COLLEGE OF ENGINEERING & TECHNOLOGY

II Year B. Tech, ANE-I Sem

<b>L</b>	<b>T/P/D</b>	<b>C</b>
<b>2</b>	<b>1/-/-</b>	<b>3</b>

## ( R24A2103 ) ENGINEERING THERMODYNAMICS

### Objectives

:

- Learn about concepts and laws used in thermodynamics.
- Students acquire knowledge of various cycles.
- Students gain information about the working principle of different engines.

### UNIT - I

**Introduction: Basic Concepts:** System, Control Volume, Surrounding, Boundaries, Universe, Types of Systems, Macroscopic and Microscopic view points, Thermodynamic Equilibrium, State, Property, Process, Exact & Inexact Differentials, Cycle - Reversibility - Quasi - static Process, Irreversible Process, Causes of Irreversibility - Energy in State and in Transition, Types, Displacement & Other forms of Work, Heat, Point and Path functions, Zeroth Law of Thermodynamics - Concept of Temperature - First law of Thermodynamics – applied to a process and system, Corollaries , Steady Flow Energy Equation.

### UNIT - II

Second Law of Thermodynamics, Kelvin-Planck and Clausius Statements and their Equivalence / Corollaries, PMM of Second kind, Carnot's principle, Carnot cycle and its specialties, Thermodynamic scale of Temperature, Clausius Inequality, Entropy, Principle of Entropy Increase - Energy Equation, Availability and Irreversibility

### UNIT - III

Perfect Gas Laws - Equation of State, specific and Universal Gas constants - various Non-flow processes, properties, end states, Heat and Work Transfer, changes in Internal Energy - Throttling and Free Expansion Processes - Flow processes. Perfect Gas Model, derivations - Vander Waals Equation of State - Compressibility charts - variable specific Heats - Gas Tables - Dryness Fraction - Clausius - Clapeyron Equation Property tables.

### UNIT - IV

Mixtures of perfect Gases - Mole Fraction, Mass fraction Gravimetric and volumetric Analysis - Dalton's law of partial pressure, Avogadro's Laws of additive volumes - Mole fraction, Volume fraction and partial pressure, Equivalent Gas const. and Molecular Internal Energy. Enthalpy, specific heats. Heats and Entropy of Mixture of perfect Gases and Vapour, Atmospheric air.

### UNIT - V

**Thermodynamic Cycles:** Power cycles: Otto, Diesel, Dual Combustion cycles, Lenoir Cycle - Description and representation on P-V and T-S diagram, Thermal Efficiency, Mean Effective Pressures on Air standard basis - comparison of Cycles. Application of Brayton cycles in aviation.

### Text Books:

1. Engineering Thermodynamics, Special Edition - MRCET, McGrawHill Publishers-2017
2. Engineering Thermodynamics / PK Nag / TMH, 5th Edition
3. Engineering Thermodynamics / E Rathakrishnan / PHI / Second Edition / 2013

### Reference Books:

1. Engineering Thermodynamics / DP Mishra / Cengage Learning / Second impression 2012
2. Thermodynamics - An Engineering Approach - Yunus Cengel & Boles / TMH
3. Thermodynamics - J.P. Holman / McGrawHill

4. Engineering thermodynamics - Jones & Dugan

5. Engineering Thermodynamics / P. Chattopadhyay / Oxford higher Education / Revised First Edition
6. Thermodynamics & Heat Engines - Yadav - Central Book Dept. Allahabad

**Outcomes:**

- Basic concepts can be applied by the students
- Students can correlate cycles applicable for engines.
- Students should be able to analyze the relationship between various processes and working mechanisms of the engines.

Code No: R15A0364

# MALLA REDDY COLLEGE OF ENGINEERING & TECHNOLOGY

R15

(Autonomous Institution – UGC, Govt. of India)

II B.Tech I Semester supplementary Examinations, May 2019

## Thermodynamics

(AE)

Roll No									
---------	--	--	--	--	--	--	--	--	--

Time: 3 hours

Max. Marks: 75

**Note:** This question paper contains two parts A and B

Part A is compulsory which carries 25 marks and Answer all questions.

Part B Consists of 5 SECTIONS (One SECTION for each UNIT). Answer FIVE Questions, Choosing ONE Question from each SECTION and each Question carries 10 marks.

\*\*\*\*\*

### PART – A

(25 Marks)

1. (a) Define first law of thermodynamics. Also write its mathematical form applied to a cyclic process. (2M)
- (b) In a polytropic expansion process, 340 kPa and  $0.0425 \text{ m}^3$  are the pressure and volume at the initial state respectively. Calculate the final volume if the final pressure is 136 kPa. Assume polytropic index as 1.3 (3M)
- (c) State Carnot theorem and its corollary (2M)
- (d) Predict the nature of a cycle based on the Clausius inequality. (3M)
- (e) Define dryness fraction. What is the dryness fraction for the pure substance on saturated vapor line? (2M)
- (f) Why does the isobaric lines on specific enthalpy (h) - specific entropy (s) are not parallel to each other. (3M)
- (g) Define Dew point temperature (2M)
- (h) Prove that for an ideal gas the pressure fraction and volume fraction is equal to mole fraction. (3M)
- (i) Define Ton of Refrigeration. (2M)
- (j) State Dalton's law of partial pressures and Avogadro's Laws of additive volumes. (3M)

### PART – B

(50 Marks)

#### SECTION – I

2. The volume of 1 kg of helium in a piston-cylinder device is initially  $7 \text{ m}^3$ . Now, helium is compressed to  $3 \text{ m}^3$  and 150 kPa by the law  $pv^{1.23} = \text{constant}$ . Determine the initial and final temperatures of helium as well as the work required to compress it, in kJ. Assume the molecular weight of helium to be 4. (10M)

(OR)

3. Derive the steady flow energy equation for flow through compressor and

nozz  
le.

SECTION – II

4. Establish the equivalence among Kelvin-Planck and Clausius statements. **(10M)**  
**(OR)**
5. (a) Derive Vanderwall's equation of state **(5M)**

- (b) Establish the inequality of Clausius. (5M)

SECTION – III

6. (a) A fluid undergoes a reversible adiabatic compression from 4 bar,  $0.3\text{m}^3$  to  $0.08\text{m}^3$  according to the law,  $pv^{1.25} = \text{constant}$ . Determine (i) Change in (5M)

enthalpy, (ii) Change in internal energy

- (b) Discuss the phase change process of pure substance by using T-s (Temperature - specific entropy) diagram. (5M)

(OR)

7. (a) 1.5 kg of liquid having a constant specific heat of 2.5 kJ/kg K, is stirred in a well insulated chamber that causes the temperature rise by  $15^\circ\text{C}$ . Find the change in internal energy and work done during the process. (5M)

- (b) Calculate volume, density, enthalpy and entropy of 2 kg of steam at  $80^\circ\text{C}$ , having a dryness fraction of 0.85. (5M)

SECTION – IV

8. (a) A Mixture of ideal gases consists of 3 kg of  $\text{N}_2$ , 5 kg of  $\text{CO}_2$  at a pressure of 300 kPa and a temperature of  $20^\circ\text{C}$ . Find out (10M)

- (i) Mole fraction of each component.  
 (ii) The equivalent weight of molecular mixture.  
 (iii) The equivalent gas constant of the mixture.  
 (iv) The partial pressure and partial volume.  
 (v) The volume and density of the mixture.  
 (vi) The  $C_p$  and  $C_v$  of the mixture.

If the mixture is heated at constant volume to  $40^\circ\text{C}$ , find the changes in internal energy, enthalpy and entropy of the mixture.

(OR)

9. (b) The air at  $28^\circ\text{C}$  and 1 bar has a specific humidity of 0.016 kg per kg of dry air. Determine (i) Partial pressure of water vapour (ii) Relative humidity (iii) Dew point temperature (5M)

- (c) Sketch the psychrometric chart and explain the properties of moist air. (5M)

SECTION – V

10. (a) Formulate the air standard efficiency of Otto cycle with the help of P-V and T-S diagrams. (10M)

(OR)

11. (b) In an air standard Brayton cycle the pressure ratio is 7 and the maximum temperature of the cycle is  $800^\circ\text{C}$ . The compression begins at 0.1Mpa,  $35^\circ\text{C}$ . Find (i) the heat supplied per kg of air, (ii) the net work done per kg of air, (iii) the cycle efficiency (10M)

\*\*\*\*

Code No: R17A0364

**MALLA REDDY COLLEGE OF ENGINEERING & TECHNOLOGY****(Autonomous Institution – UGC, Govt. of India)**

II B.Tech I Semester Supplementary Examinations, May 2019

**Thermodynamics****(AE)**

<b>Roll No</b>										
----------------	--	--	--	--	--	--	--	--	--	--

**Time: 3 hours****Max. Marks: 70**

**Note:** This question paper Consists of 5 Sections. Answer **FIVE** Questions, Choosing **ONE** Question from each SECTION and each Question carries 14 marks.

\*\*\*\*\*

SECTION-I

**1 A** Explain the concept of SFEE to boiler, Throttling and Nozzle [8M]

**1 B** A certain water heater operates under steady flow conditions receiving 4.2 kg/s of water at 75°C temperature, enthalpy 313.93 kJ/kg. the water is heated by mixing with steam which is supplied to the heater at temperature 100.2°C and enthalpy 2627kJ/kg. the mixture leaves the heater as liquid water at temperature 100°C and enthalpy 419 kJ/kg. how much steam must be supplied to the heater per hour? [6M]

OR

**2 A** Distinguish between the terms [9M]

- I. Change of state
- II. Path
- III. process

**2B** Helium at 300kPa, 60°C enters a nozzle with negligible velocity and expands steadily without heat transfer in a quasi-equilibrium manner to 120 kPa. Process is  $pv^{1.67} = \text{const}$ . Calculate exit velocity [5M]

SECTION-II

**3 A** What are the causes of entropy increase? [5M]

**3 B** One kg ice at -5°C is exposed to the atmosphere which is at 20°C. the ice melts and comes into thermal equilibrium with the atmosphere. (I) Determine the entropy increase of the universe. (II) what is the minimum amount of work necessary to convert the water back in to ice at -5°C? Cp of ice is 2.093 kJ/kg K and the latent heat of fusion of ice is 333.3 kJ/Kg. [9M]

OR

**4 A** What is a heat pump? How does it differ from a refrigerator? [4M]

**4 B** A reversible heat engine operates between two reservoirs at temperatures of 600°C and 40°C. the engine drives a reversible refrigerator which operates between reservoirs at temperatures of 40°C and -20°C. the heat transfer to the heat engine is 2000 kJ and the network output of the combined engine refrigerator plant is 360 kJ. A) evaluate the heat transfer to the refrigerant and the net heat transfer to the reservoir at 40°C. [10M]  
B) reconsider (A) given that the efficiency of the heat engine and the cop of the refrigerator are each 40% of their maximum possible values.

SECTION-III

**5 A** Explain the the  
4



**5 B** A rigid vessel of capacity 0.2 m<sup>3</sup> holds 10 bar steam at 250°C. The vessel is slowly cooled till the steam pressure drops to 3.5 bar. Determine the (i) final temperature and dryness fraction of steam; (ii) change in entropy. [7M]

OR

**6** With the help of neat sketch Explain how quality of steam is measured by separating and throttling calorimeter [14M]

**SECTION-IV**

**7 A** What is enthalpy of air-vapour mixture? Discuss why does the enthalpy of air – vapour mixture remains constant during an adiabatic saturation process. [7M]

**7 B** A mass of 0.25 kg of an ideal gas has a pressure of 300 kPa, a temperature of 80°C, and a volume of 0.07 m<sup>3</sup>. The gas undergoes an irreversible adiabatic process to a final pressure of 300 kPa and a final volume of 0.1 m<sup>3</sup>, during which the work done on the gas is 25 kJ. Evaluate the specific heat at constant pressure and constant volume of the gas and the increase in entropy of the gas. [7M]

OR

**8** Briefly Explain the following [14M]

- I. Dry bulb Temperature,
- II. Wet bulb temperature
- III. Dew point temperature,
- IV. Relative humidity
- V. Specific humidity
- VI. Psychrometer
- VII. Sensible heating and cooling

**SECTION-V**

**9 A** With the help of P-V and T-S. derive the air standard efficiency of diesel cycle [7M]

**9 B** A theoretical diesel engine operates at suction conditions of 1 bar and 300 K. At the end of compression stroke, the pressure rises to 24 bar. The maximum temperature limit of the cycle is 1473K. Determine (i) cut-off ratio; (ii) net work output of the cycle and (iii) thermal efficiency of the cycle. For air, assume specific heat at constant pressure and volume as 1.005 kJ/kg.K and 0.717 kJ/kg.K. [7M]

OR

**10 A** Explain a vapour compression refrigeration cycle using T-S and P-h diagrams and derive its COP [7M]

**10 B** For the same compression ratio and heat rejection, which cycle is more efficient: Otto, Diesel or Dual cycle. Explain with P-V and T-s diagrams [7M]

\*\*\*\*\*

## UNIT I

**System:**

A thermodynamic system is defined as a quantity of matter or a region in space which is selected for the study.

**Surroundings:**

The mass or region outside the system is called surroundings.

**Boundary:**

The real or imaginary surfaces which separates the system and surroundings is called boundary. The real or imaginary surfaces which separates the system and surroundings is called boundary.

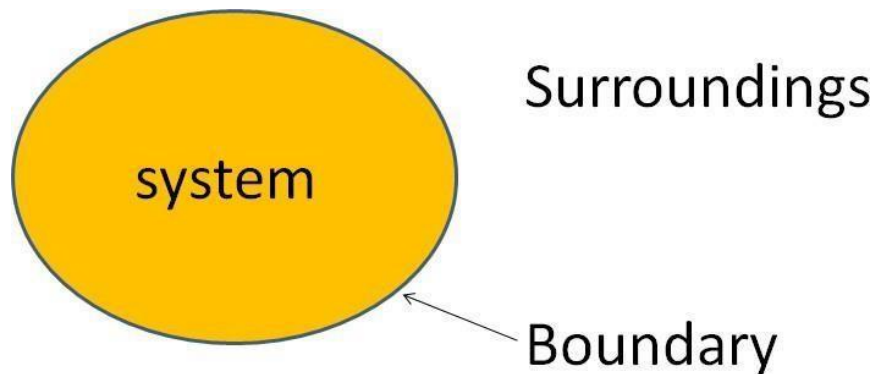
**Types of thermodynamic system**

On the basis of mass and energy transfer the thermodynamic system is divided into three types.

1. Closed system
2. Open system
3. Isolated system

**Closed system:** A system in which the transfer of energy but not mass can take place across the boundary is called closed system. The mass inside the closed system remains constant.

For example: Boiling of water in a closed vessel. Since the water is boiled in a closed vessel so the mass of water cannot escape out of the boundary of the system but heat energy continuously enters and leaves the boundary of the vessel. It is an example of a closed system.

**Open system:** A system in which the transfer of both mass and energy takes place is called an open system. This system is also known as control volume.

For example: Boiling of water in an open vessel is an example of an open system because the water and heat energy both enter and leave the boundary of the vessel.

**Isolated system:** A system in which the transfer of mass and energy cannot take place is called an isolated system.

For example: Tea present in a thermos flask. In this the heat and the mass of the tea cannot cross the boundary of the thermos flask. Hence the thermos flask is an isolated system.

Control Volume:

- Its a system of fixed volume.
- This type of system is usually referred to as "open system" or a "control volume"
- Mass transfer can take place across a control volume.
- Energy transfer may also occur into or out of the system.
- Control Surface- Its the boundary of a control volume across which the transfer of both mass and energy takes place.
- The mass of a control volume (open system) may or may not be fixed.
- When the net influx of mass across the control surface equals zero then the mass of the system is fixed and vice-versa.
- The identity of mass in a control volume always changes unlike the case for a control mass system (closed system).
- Most of the engineering devices, in general, represent an open system or control volume.

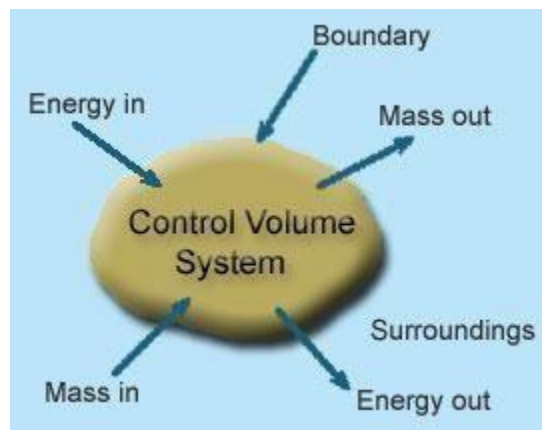

Example:

Heat exchanger - Fluid enters and leaves the system continuously with the transfer of heat across the system boundary.

Pump - A continuous flow of fluid takes place through the system with a transfer of mechanical energy from the surroundings to the system

**Microscopic Approach:**

- The approach considers that the system is made up of a very large number of discrete particles known as molecules. These molecules have different velocities and energies. The values of these energies are constantly changing with time. This approach to thermodynamics, which is concerned directly with the structure of the matter, is known as statistical thermodynamics.
- The behavior of the system is found by using statistical methods, as the number of molecules is very large. So advanced statistical and mathematical methods are needed to explain the changes in the system.
- The properties like velocity, momentum, impulse, kinetic energy and instruments cannot easily measure force of impact etc. that describe the molecule.
- Large numbers of variables are needed to describe a system. So the approach is complicated.

**Macroscopic Approach:**

- In this approach a certain quantity of matter is considered without taking into account the events occurring at molecular level. In other words this approach to thermodynamics is concerned with gross or overall behavior. This is known as classical thermodynamics.
- The analysis of macroscopic system requires simple mathematical formula.
- The value of the properties of the system are their average values. For examples consider a sample of gas in a closed container. The pressure of the gas is the average value of the pressure exerted by millions of individual molecules.
- In order to describe a system only a few properties are needed.

S.No	Macroscopic Approach	Microscopic Approach
1	In this approach a certain quantity of matter is considered without taking into account the events occurring at molecular level.	The matter is considered to be comprised of a large number of tiny particles known as molecules, which moves randomly in chaotic fashion. The effect of molecular motion is considered.
2	Analysis is concerned with overall behavior of the system.	The Knowledge of the structure of matter is essential in analyzing the behavior of the system.
3	This approach is used in the study of classical thermodynamics.	This approach is used in the study of statistical thermodynamics.
4	A few properties are required to describe the system.	Large numbers of variables are required to describe the system.
5	The properties like pressure, temperature, etc. needed to describe the system, can be easily measured.	The properties like velocity, momentum, kinetic energy, etc. needed to describe the system, cannot be measured easily.

6	The properties of the system are their average values.	The properties are defined for each molecule individually.
7	This approach requires simple mathematical formulas for analyzing the system.	No. of molecules are very large so it requires advanced statistical and mathematical method to explain any change in the system.

**Thermodynamic Equilibrium:**

A thermodynamic system is said to exist in a state of thermodynamic equilibrium when no change in any macroscopic property is registered if the system is isolated from its surroundings. An isolated system always reaches in the course of time a state of thermodynamic equilibrium and can never depart from it spontaneously.

Therefore, there can be no spontaneous change in any macroscopic property if the system exists in an equilibrium state. A thermodynamic system will be in a state of thermodynamic equilibrium if the system is the state of Mechanical equilibrium, Chemical equilibrium and Thermal equilibrium.

- Mechanical equilibrium: The criteria for Mechanical equilibrium is the equality of pressures.
- Chemical equilibrium: The criteria for Chemical equilibrium is the equality of chemical potentials.
- Thermal equilibrium: The criteria for Thermal equilibrium is the equality of temperatures.

**State:**

The thermodynamic state of a system is defined by specifying values of a set of measurable properties sufficient to determine all other properties. For fluid systems, typical properties are pressure, volume and temperature. More complex systems may require the specification of more unusual properties. As an example, the state of an electric battery requires the specification of the amount of electric charge it contains.

**Property:**

Properties may be extensive or intensive.

Intensive properties: The properties which are independent of the mass of the system. For example: Temperature, pressure and density are the intensive properties.

Extensive properties: The properties which depend on the size or extent of the system are called extensive properties.

For example: Total mass, total volume and total momentum.

**Process:**

When the system undergoes change from one thermodynamic state to final state due change in properties like temperature, pressure, volume etc, the system is said to have undergone thermodynamic process.

Various types of thermodynamic processes are: isothermal process, adiabatic process, isochoric process, isobaric process and reversible process.

**Cycle:**

Thermodynamic cycle refers to any closed system that undergoes various changes due to temperature, pressure, and volume, however, its final and initial state are equal. This cycle is important as it allows for the continuous process of a moving piston seen in heat engines and the expansion/compression of the working fluid in refrigerators, for example. Without the cyclical process, a car wouldn't be able to continuously move when fuel is added, or a refrigerator would not be able to stay cold.

Visually, any thermodynamic cycle will appear as a closed loop on a pressure volume diagram. Examples: Otto cycle, Diesel Cycle, Brayton Cycle etc.

**Reversibility:**

Reversibility, in thermodynamics, a characteristic of certain processes (changes of a system from an initial state to a final state spontaneously or as a result of interactions with other systems) that can be reversed, and the system restored to its initial state, without leaving net effects in any of the systems involved.

An example of a reversible process would be a single swing of a frictionless pendulum from one of its extreme positions to the other. The swing of a real pendulum is irreversible because a small amount of the mechanical energy of the pendulum would be expended in performing work against frictional forces, and restoration of the pendulum to its exact starting position would require the supply of an equivalent amount of energy from a second system, such as a compressed spring in which an irreversible change of state would occur.

**Quasi static process:**

When a process is processing in such a way that system will be remained infinitesimally close with equilibrium state at each time, such process will be termed as quasi static process or quasi equilibrium process.

In simple words, we can say that if system is going under a thermodynamic process through succession of thermodynamic states and each state is equilibrium state then the process will be termed as quasi static process.

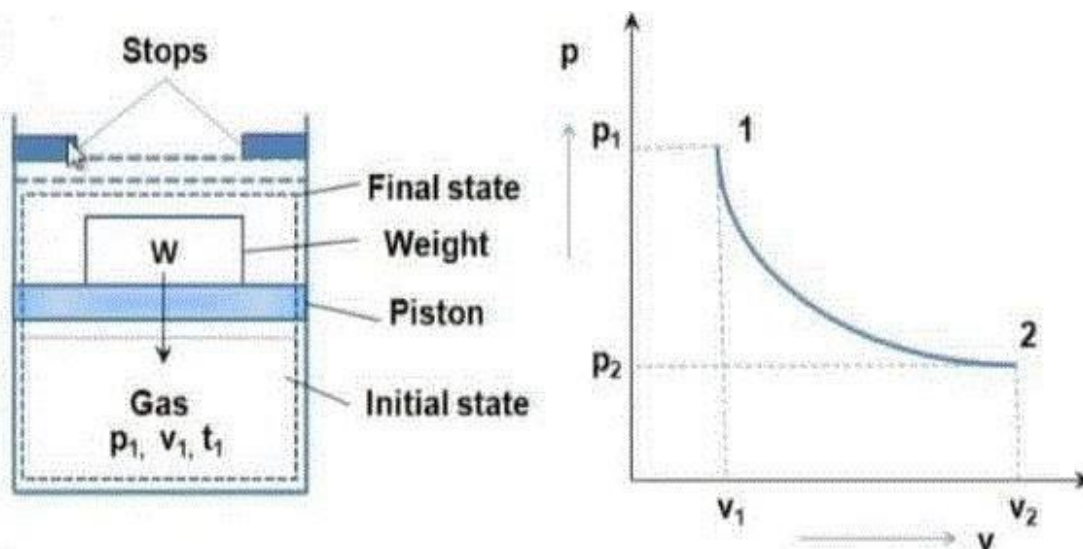

We will see one example for understanding the quasi static process, but let us consider one simple example for better understanding of quasi static process. If a person is coming down from roof to ground floor with the help of ladder steps then it could be considered as quasi static process. But if he jumps from roof to ground floor then it will not be a quasi static process. Weight placed over the piston is just balancing the force which is exerted in upward direction by gas. If we remove the weight from the piston, system will have unbalanced force and piston will move in upward direction due to force acting over the piston in upward direction by the gas.

#### Irreversible Process:

The irreversible process is also called the natural process because all the processes occurring in nature are irreversible processes. The natural process occurs due to the finite gradient between the two states of the system. For instance, heat flow between two bodies occurs due to the temperature gradient between the two bodies; this is in fact the natural flow of heat. Similarly, water flows from high level to low level, current moves from high potential to low potential, etc.

- In the irreversible process the initial state of the system and surroundings cannot be restored from the final state.
- During the irreversible process the various states of the system on the path of change from initial state to final state are not in equilibrium with each other.
- During the irreversible process the entropy of the system increases decisively and it cannot be reduced back to its initial value.
- The phenomenon of a system undergoing irreversible process is called as irreversibility.

Causes of Irreversibility:

Friction: Friction is invariably present in real systems. It causes irreversibility in the process as work done does not show an equivalent rise in the kinetic or potential energy of the system. The fraction of energy wasted due to frictional effects leads to deviation from reversible states.

Free expansion: Free expansion refers to the expansion of unresisted type such as expansion in a vacuum. During this unresisted expansion the work interaction is zero, and without the expense of any work, it is not possible to restore initial states. Thus, free expansion is irreversible.

Heat transfer through a finite temperature difference: Heat transfer occurs only when there exist temperature difference between bodies undergoing heat transfer. During heat transfer, if heat addition is carried out in a finite number of steps then after every step the new state shall be a non-equilibrium state.

Nonequilibrium during the process: Irreversibilities are introduced due to lack of thermodynamic equilibrium during the process. Non-equilibrium may be due to mechanical inequilibrium, chemical inequilibrium, thermal inequilibrium, electrical inequilibrium, etc. and irreversibility is called mechanical irreversibility, chemical irreversibility, thermal irreversibility, electrical irreversibility respectively. Factors discussed above are also causing non-equilibrium during the process and therefore make process irreversible.

Heat:

It is the energy in transition between the system and the surroundings by virtue of the difference in temperature. Heat is energy transferred from one system to another solely by reason of a temperature difference between the systems. Heat exists only as it crosses the boundary of a system and the direction of heat transfer is from higher temperature to lower temperature. For thermodynamics sign convention, heat transferred to a system is positive; Heat transferred from a system is negative.

Work:

Thermodynamic definition of work: Positive work is done by a system when the sole effect external to the system could be reduced to the rise of a weight.

Work done BY the system is positive and work done ON the system is negative.

Types of work interaction:

- Expansion and compression work (displacement work)
- Work of a reversible chemical cell
- Work in stretching of a liquid surface
- Work done on elastic solids
- Work of polarization and magnetization

Point and Path functions:

- Point function does not depend on the history (or path) of the system. It only depends on the state of the system.
- Examples of point functions are: temperature, pressure, density, mass, volume, enthalpy, entropy, internal energy etc.

- Path function depends on history of the system (or path by which system arrived at a given state).
- Examples for path functions are work and heat.
- Path functions are not properties of the system, while point functions are properties of the system.
- Change in point function can be obtained by from the initial and final values of the function, whereas path has to defined in order to evaluate path functions.

#### Zeroth Law of Thermodynamics:

The Thermodynamics Zeroth Law states that if two systems are at the same time in thermal equilibrium with a third system, they are in equilibrium with each other.

If an object with a higher temperature comes in contact with an object of lower temperature, it will transfer heat to the lower temperature object. The objects will approach the same temperature and in the absence of loss to other objects, they will maintain a single constant temperature. Therefore, thermal equilibrium is attained.

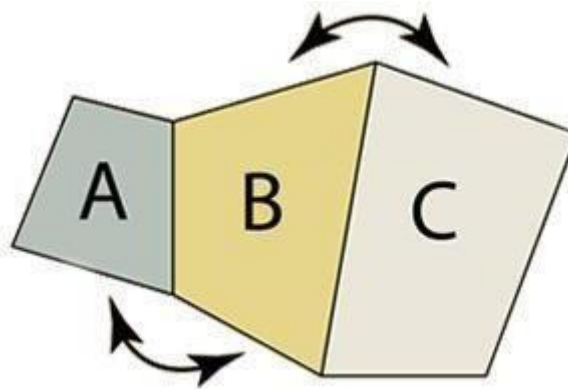

If objects 'A' and 'C' are in thermal equilibrium with 'B', then object 'A' is in thermal equilibrium with object 'C'. Practically this means all three objects are at the same temperature and it forms the basis for comparison of temperatures.

#### Principles of Thermometry:

Thermometry is the science and practice of temperature measurement. Any measurable change in a thermometric probe (e.g. the dilatation of a liquid in a capillary tube, variation of electrical resistance of a conductor, of refractive index of a transparent material, and so on) can be used to mark temperature levels, that should later be calibrated against an internationally agreed unit if the measure is to be related to other thermodynamic variables. Thermometry is sometimes split in metrological studies in two subfields: contact thermometry and noncontact thermometry. As there can never be complete thermal uniformity at large, thermometry is always associated to a heat transfer problem with some space-time coordinates of measurement, given rise to time-series plots and temperature maps.

Constant Volume gas Thermometer:

When we heat a gas keeping the volume constant, its pressure increases and when we cool the gas its pressure decreases. The relationship between pressure and temperature at constant volume is given by the law of pressure. According to this law, the pressure of a gas changes by of its original pressure at 0°C for each degree centigrade (or Celsius) rise in temperature at constant volume.

If  $P_o$  is the pressure of a given volume of a gas at 0°C and  $P_t$  is the pressure of the same volume of the gas (i.e., at constant volume) at  $t^\circ\text{C}$ , then

$$P_t = P_o + \frac{P_o}{273} \times t$$

$$P_t = P_o \left( 1 + \frac{t}{273} \right)$$

It consists of a glass bulb B connected to a tube A, through a capillary glass tube 'C'. The tube A is connected to a mercury reservoir R which is clamped on the board and can be lowered or raised whenever required to keep the volume of the air constant. The capillary tube C is provided with a three way stopper S and can be used to connect capillary and bulb as well as to disconnect tube from bulb B. A pointer is provided such that the end P is projecting inside from the upper part of A. A scale calibrated in 0°C is provided between A and R.

The whole apparatus is leveled by adjusting the leveling screws. By adjusting the stopper, the bulb 'B' is filled with air or some gas and the pointer is adjusted so that tip of the pointer just touches the level of mercury in the tube A. After filling the bulb, it is kept in an ice bath for some time till the air inside the bulb attains the temperature of ice at which the mercury level becomes stationary. Now the reservoir R is adjusted so that the level of mercury in the tube A just touches the tip of the pointer P.

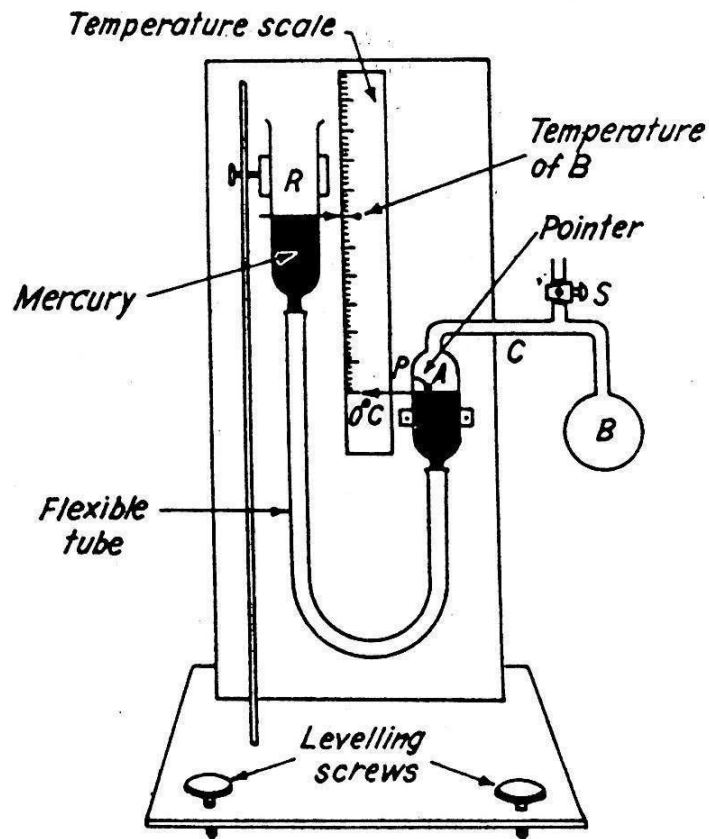

The difference between the mercury levels in the two tubes is noted and let it be  $h_0$ . If  $P_0$  is the pressure exerted by the air in the bulb, then

$$P = P_0 + \rho h_0$$

Now ice bath is removed and the bulb B is surrounded with steam.

Scales of Temperature:

There are three temperature scales in use Fahrenheit, Celsius and Kelvin. Fahrenheit temperature scale is a scale based on 32 for the freezing point of water and 212 for the boiling point of water, the interval between the two being divided into 180 parts.

The conversion formula for a temperature that is expressed on the Celsius (C) scale to its Fahrenheit (F) representation is:  $F = \frac{9}{5}C + 32$ .

Celsius temperature scale also called centigrade temperature scale, is the scale based on 0 for the freezing point of water and 100 for the boiling point of water.

Kelvin temperature scale is the base unit of thermodynamic temperature measurement in the International System (SI) of measurement. It is defined as  $\frac{1}{273.16}$  of the triple point (equilibrium among the solid, liquid, and gaseous phases) of pure water.

### PERPETUAL MOTION MACHINE OF THE FIRST KIND—PMM1

The first law states the general principle of the conservation of energy. *Energy is neither created nor destroyed, but only gets transformed from one form to another.* There can be no machine which would continuously supply mechanical work without some other form of energy disappearing simultaneously (Fig. 4.8). Such a *fictitious machine* is called a *perpetual motion machine of the first kind*, or in brief, PMM1. *A PMM1 is thus impossible.*

The converse of the above statement is also true, i.e. there can be no machine which would continuously consume work without some other form of energy appearing simultaneously (Fig. 4.9).

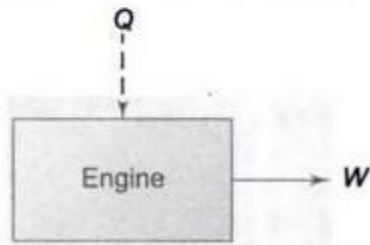

Fig. 4.8 A PMM1

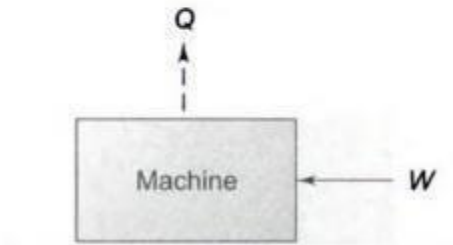
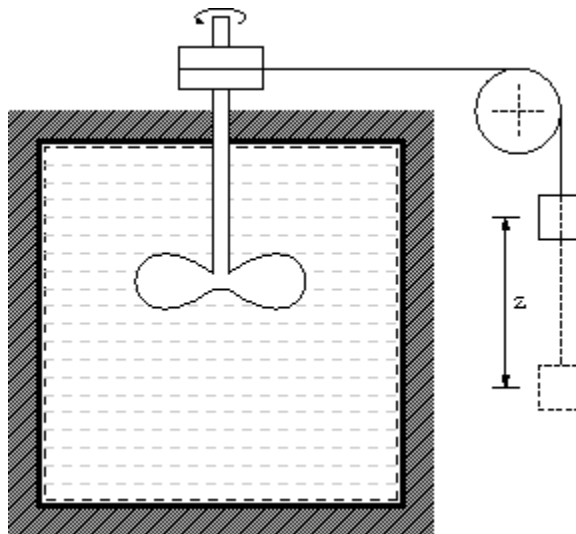

Fig. 4.9 The Converse of PMM1

Joule experiment:



James P. Joule carried out his famous experiment; he placed known amounts of water, oil, and mercury in an insulated container and agitated the fluid with a rotating stirrer. The amounts of work done on the fluid by the stirrer were accurately measured, and the temperature changes of the fluid were carefully noted. He found for each fluid that a fixed amount of work was required per unit mass for every degree of temperature rise caused by the stirring, and that the original temperature of the fluid could be restored by the transfer of heat through simple contact with a cooler object. In this experiment you can conclude there is a relationship between heat and work or in other words heat is a form of energy.

## Internal Energy

Through, Joule experiment what happen to energy between time it is added to water as work, and time it is extracted to heat? Logic suggests that this energy contained in the water in another form which called internal energy.

Internal energy refers to energy of molecules of substance which are ceaseless motion and possess kinetics energy. The addition of heat to a substance increases this molecular activity, and thus causes an increase in its internal energy. Work done on the substance can have the same effect, as was shown by Joule. Internal energy cannot be directly measured; there are no internal-energy meters. As a result, absolute values are unknown. However, this is not a disadvantage in thermodynamic analysis, because only changes in internal energy are required.

### First Law of Thermodynamics:

During a thermodynamic cycle, a cyclic process the systems undergoes, the cyclic integral of heat added is equal to integral of work done. The first law equation can also be written in the form,

$$\oint (dQ - dW) = 0$$

Equation  $dU = dQ - dW$  is a corollary to the first law of thermodynamics. It shows that there exists a property internal energy ( $U$ ) of the system, such that a change in its value is equal to the difference in heat entering and work leaving the system.

The First law of thermodynamics states that energy is neither created nor destroyed. Thus the total energy of the universe is a constant. However, energy can certainly be transferred from one form to another form.

The 1st law of thermodynamics can be mathematically stated as follows:

$$\oint dQ = \oint dW$$

### Corollary 1:

There exists property of closed system; the change in value of this property during the process is given by the difference between heat supplied and work done.

$$dU = dQ - dW$$

Here  $E$  is property of system and is called as total energy that includes internal energy, kinetic energy, potential energy, electrical energy, magnetic energy, chemical energy, etc.

### Corollary 2:

For the isolated system, heat and work both interactions are absent ( $dQ = 0, dW = 0$ ) and  $E = \text{constant}$ . Energy can neither be created nor be destroyed; but, it can be converted from one form to other.

Corollary 3:

A perpetual motion machine of first kind is almost impossible.

Flow Process

Steady flow energy equation:

Virtually all the practical systems involve flow of mass across the boundary separating the system and the surroundings. Whether it be a steam turbine or a gas turbine or a compressor or an automobile engine there exists flow of gases/gas mixtures into and out of the system. So we must know how the first Law of thermodynamics can be applied to an open system.

The fluid entering the system will have its own internal, kinetic and potential energies.

Let  $u_1$  be the specific internal energy of the fluid entering  $C_1$  be the velocity of the fluid while entering  $Z_1$  be the potential energy of the fluid while entering Similarly let  $u_2, C_2$  and  $Z_2$  be respective entities while leaving.

### Energy Balance:

$$\dot{Q} + \sum_{in} \dot{m}_i (h_i + C_i^2/2 + gZ_i) = \sum_{exit} \dot{m}_e (h_e + C_e^2/2 + gZ_e) + \dot{W}$$

By applying the features of mixing chamber, the above equation reduces to,

$$\sum_{in} \dot{m}_i h_i = \sum_{exit} \dot{m}_e h_e$$

or  $\dot{m}_1 h_1 + \dot{m}_2 h_2 = \dot{m}_3 h_3$

**Example 4.1** A stationary mass of gas is compressed without friction from an initial state of  $0.3 \text{ m}^3$  and  $0.105 \text{ MPa}$  to a final state of  $0.15 \text{ m}^3$  and  $0.105 \text{ MPa}$ , the pressure remaining constant during the process. There is a transfer of  $37.6 \text{ kJ}$  of heat from the gas during the process. How much does the internal energy of the gas change?

**Solution** First law for a stationary system in a process gives

$$Q = \Delta U + W$$

or 
$$Q_{1-2} = U_2 - U_1 + W_{1-2} \quad (1)$$

Here 
$$W_{1-2} = \int_{V_1}^{V_2} p dV = p(V_2 - V_1)$$
  

$$= 0.105 (0.15 - 0.30) \text{ MJ} = -15.75 \text{ kJ}$$
  

$$Q_{1-2} = -37.6 \text{ kJ}$$

∴ Substituting in Eq. (1)

$$-37.6 \text{ kJ} = U_2 - U_1 - 15.75 \text{ kJ}$$

∴ 
$$U_2 - U_1 = -21.85 \text{ kJ}$$

The internal energy of the gas decreases by  $21.85 \text{ kJ}$  in the process.

**Example 4.2** When a system is taken from state  $a$  to state  $b$ , in Fig. 4.10 along path  $acb$ ,  $84 \text{ kJ}$  of heat flow into the system, and the system does  $32 \text{ kJ}$  of work. (a) How much will the heat that flows into the system along path  $adb$  be, if the work done is  $10.5 \text{ kJ}$ ? (b) When the system is returned from  $b$  to  $a$  along the curved path, the work done on the system is  $21 \text{ kJ}$ . Does the system absorb or liberate heat, and how much of the heat is absorbed or liberated? (c) If  $U_a = 0$  and  $U_d = 42 \text{ kJ}$ , find the heat absorbed in the processes  $ad$  and  $db$ .

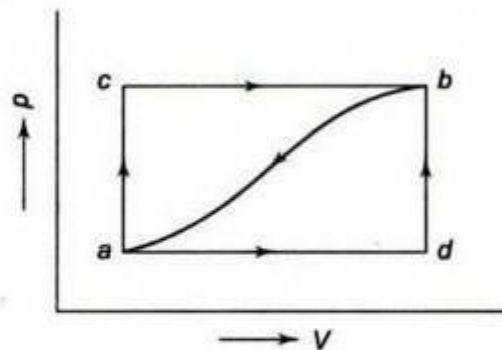

**Fig. 4.10**

**Solution**

$$Q_{acb} = 84 \text{ kJ}$$

$$W_{acb} = 32 \text{ kJ}$$

We have

$$Q_{acb} = U_b - U_a + W_{acb}$$

∴ 
$$U_b - U_a = 84 - 32 = 52 \text{ kJ}$$

(a) 
$$Q_{adb} = U_b - U_a + W_{adb}$$
  

$$= 52 + 10.5 = 62.5 \text{ kJ}$$

(b) 
$$Q_{b-a} = U_a - U_b + W_{b-a}$$
  

$$= -52 - 21 = -73 \text{ kJ}$$

The system liberates 73 kJ of heat

$$(c) \quad W_{adb} = W_{ad} + W_{db} = W_{ad} = 10.5 \text{ kJ}$$

$$\begin{aligned} \therefore \quad Q_{ad} &= U_d - U_a + W_{ad} \\ &= 42 - 0 + 10.5 = 52.5 \text{ kJ} \end{aligned}$$

$$\text{Now} \quad Q_{adb} = 62.5 \text{ kJ} = Q_{ad} + Q_{db}$$

$$\therefore \quad Q_{db} = 62.5 - 52.5 = 10 \text{ kJ}$$

**Example 4.3** A piston and cylinder machine contains a fluid system which passes through a complete cycle of four processes. During a cycle, the sum of all heat transfers is  $-170 \text{ kJ}$ . The system completes 100 cycles per min. Complete the following table showing the method for each item, and compute the net rate of work output in kW.

Process	$Q$ (kJ/min)	$W$ (kJ/min)	$\Delta E$ (kJ/min)
$a-b$	0	2,170	—
$b-c$	21,000	0	—
$c-d$	-2,100	—	-36,600
$d-a$	—	—	—

**Solution** Process  $a-b$ :

$$\begin{aligned} Q &= \Delta E + W \\ 0 &= \Delta E + 2170 \end{aligned}$$

$$\therefore \quad \Delta E = -2170 \text{ kJ/min}$$

Process  $b-c$ :

$$\begin{aligned} Q &= \Delta E + W \\ 21,000 &= \Delta E + 0 \end{aligned}$$

$$\therefore \quad \Delta E = 21,000 \text{ kJ/min}$$

Process  $c-d$ :

$$\begin{aligned} Q &= \Delta E + W \\ -2100 &= -36,600 + W \end{aligned}$$

$$\therefore \quad W = 34,500 \text{ kJ/min}$$

Process  $d-a$ :

$$\sum_{\text{cycle}} Q = -170 \text{ kJ}$$

The system completes 100 cycles/min.

$$\therefore \quad Q_{ab} + Q_{bc} + Q_{cd} + Q_{da} = -17,000 \text{ kJ/min}$$

$$0 + 21,000 - 2100 + Q_{da} = -17,000$$

$$\therefore \quad Q_{da} = -35,900 \text{ kJ/min}$$

Now  $\oint dE = 0$ , since cyclic integral of any property is zero.

$$\therefore \Delta E_{a-b} + \Delta E_{b-c} + \Delta E_{c-d} + \Delta E_{d-a} = 0$$

$$- 2170 + 21,000 - 36,600 + \Delta E_{d-a} = 0$$

$$\therefore \Delta E_{d-a} = 17,770 \text{ kJ/min}$$

$$\therefore W_{d-a} = Q_{d-a} - \Delta E_{d-a}$$

$$= - 35,900 - 17,770 = - \mathbf{53,670 \text{ kJ/min}}$$

The table becomes

Process	$Q$ (kJ/min)	$W$ (kJ/min)	$\Delta E$ (kJ/min)
$a-b$	0	2170	- 2170
$b-c$	21,000	0	21,000
$c-d$	-2100	34,500	- 36,600
$d-a$	-35,900	- 53,670	17,770

Since 
$$\sum_{\text{cycle}} Q = \sum_{\text{cycle}} W$$

Rate of work output

$$= - 17,000 \text{ kJ/min} = - \mathbf{283.3 \text{ kW}}$$

## UNIT-II

### Limitations of the First Law:

- The first law of thermodynamics merely indicates that in any process there is a transformation between the various forms of energy involved in the process but provides no information regarding the feasibility of such transformation.
- First law does not provide any information regarding the direction processes will take whether it is a spontaneous or a nonspontaneous process.

### Thermal Reservoir:

A thermal reservoir is a large system (very high mass  $\times$  specific heat value) from which a quantity of energy can be absorbed or added as heat without changing its temperature. The atmosphere and sea are examples of thermal reservoirs. Any physical body whose thermal energy capacity is large relative to the amount of energy it supplies or absorbs can be modelled as a thermal reservoir. A reservoir that supplies energy in the form of heat is called a source and one that absorbs energy in the form of heat is called a sink.

### Heat Engine:

It is a cyclically operating device which absorbs energy as heat from a high temperature reservoir, converts part of the energy into work and rejects the rest of the energy as heat to a thermal reservoir at low temperature.

The working fluid is a substance, which absorbs energy as heat from a source, and rejects energy as heat to a sink.

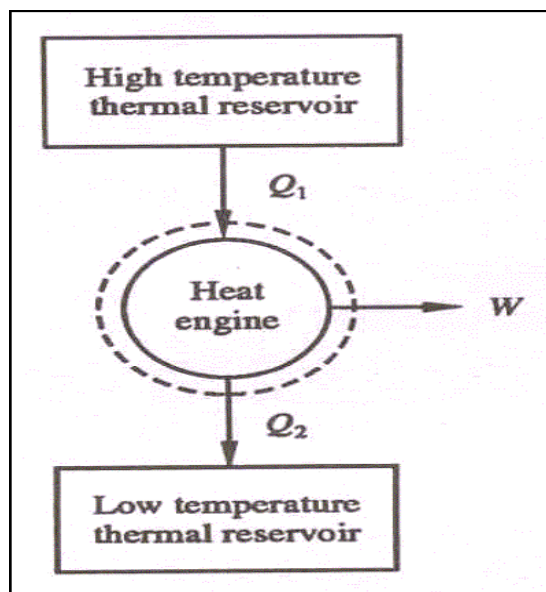

Schematic representation of Heat Engine

### Heat pump:

A heat pump is a device that transfers heat energy from a source of heat to what is called a heat sink. Heat pumps move thermal energy in the opposite direction of spontaneous heat transfer, by absorbing heat from a cold space and releasing it to a warmer one. A heat pump uses a small amount of external power to accomplish the work of transferring energy from the heat source to the heat sink. The most common design of a heat pump involves four main components – a condenser, an expansion valve, an evaporator and a compressor. The heat transfer medium circulated through these components is called refrigerant.

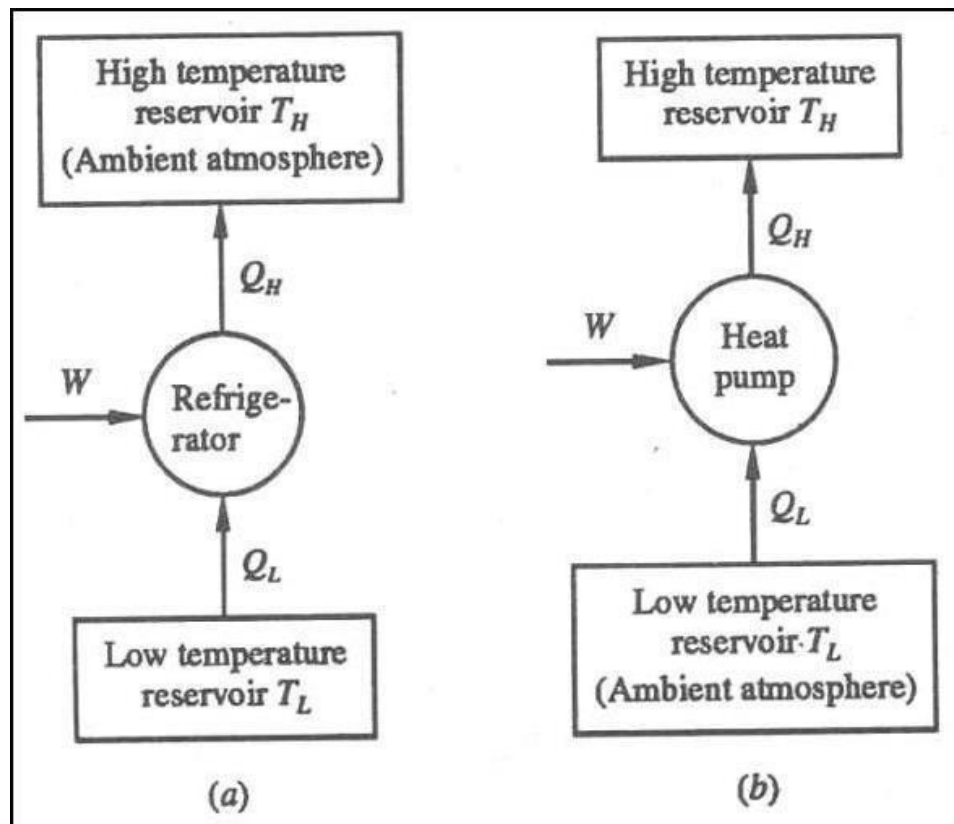

Schematic representation of Heat Pump

### Coefficient of Performance

The coefficient of performance, COP, of a refrigerator is defined as the heat removed from the cold reservoir  $Q_{\text{cold}}$ , (i.e. inside a refrigerator) divided by the work  $W$  done to remove the heat (i.e. the work done by the compressor).

COP - coefficient of performance - equation

As can be seen, the better (more efficient) the refrigerator is when more heat  $Q_{\text{cold}}$  can be removed from the inside of the refrigerator for a given amount of work. Since the first law

of thermodynamics must be valid also in this case ( $Q_{\text{cold}} + W = Q_{\text{hot}}$ ), we can rewrite the above equation:

The COP for heating and cooling are thus different, because the heat reservoir of interest is different. When one is interested in how well a machine cools, the COP is the ratio of the heat removed from the cold reservoir to input work. However, for heating, the COP is the ratio of the heat removed from the cold reservoir plus the input work to the input work: medium to a high-temperature is called heat pump.

### Coefficient of Performance of a Refrigerator and a Heat Pump

The coefficient of performance for cooling of a refrigerator, and for heating of a heat pump can now be expressed as

$$COP_C = \frac{Q_L}{W} = \frac{Q_L}{Q_H - Q_L} = \frac{1}{\frac{Q_H}{Q_L} - 1}$$

$$COP_H = \frac{Q_H}{W} = \frac{Q_H}{Q_H - Q_L} = \frac{1}{1 - \frac{Q_L}{Q_H}}$$

It is seen that, since  $W$  is finite, both  $COP_C$  and  $COP_H$  are less than  $\infty$ . Also, from the first law equation, since  $Q_H = Q_L + W$

$$\frac{Q_H}{W} = \frac{Q_L}{W} + 1$$

$$COP_H = COP_C + 1$$

Accordingly,  $COP_H$  is always greater than unity. It is so since  $Q_H$  is always greater than  $Q_L$  by the amount  $W$ .

### Perpetual motion machine of the second kind

The first law of thermodynamics does not stipulate any restriction on the thermal efficiency of a heat engine. However, the second law restricts the thermal efficiency of a heat engine to less than one. It stipulates that some portion of the energy absorbed as heat from a source must always be rejected to a low temperature sink. Wilhelm Ostwald introduced the concept of Perpetual Motion Machine of the Second Kind, that is, of a device which could perform work solely by absorbing energy as heat from a single thermal reservoir (see Fig. 7.4). Clearly, such a device does not violate the first law of thermodynamics because it would perform work at the expense of the internal energy of a body. A Perpetual Motion Machine of the Second Kind (PMMSK) is a hypothetical device which, working cyclically, receives energy as heat from a single thermal reservoir and delivers an equivalent amount of work.

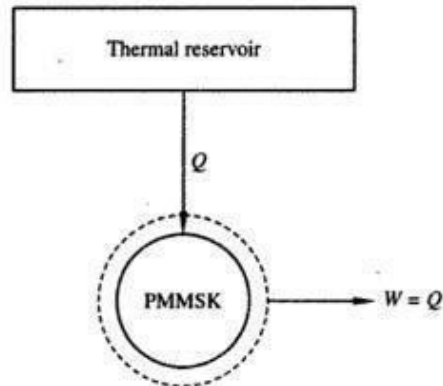

Fig. 7.4 Perpetual motion machine of the second kind



## REVERSIBLE AND IRREVERSIBLE PROCESSES

The second law of thermodynamics states that no heat engine can have an efficiency of 100 percent. Then one may ask, What is the highest efficiency that a heat engine can possibly have? Before we can answer this question, we need to define an idealized process first, which is called the *reversible process*.

The processes that were discussed at the beginning of this chapter occurred in a certain direction. Once having taken place, these processes cannot reverse themselves spontaneously and restore the system to its initial state. For this reason, they are classified as *irreversible processes*. Once a cup of hot coffee cools, it will not heat up by retrieving the heat it lost from the surroundings. If it could, the surroundings, as well as the system (coffee), would be restored to their original condition, and this would be a reversible process.

A **reversible process** is defined as a *process that can be reversed without leaving any trace on the surroundings* (Fig. 6–30). That is, both the system *and* the surroundings are returned to their initial states at the end of the reverse process. This is possible only if the net heat *and* net work exchange between the system and the surroundings is zero for the combined (original and reverse) process. Processes that are not reversible are called **irreversible processes**.

It should be pointed out that a system can be restored to its initial state following a process, regardless of whether the process is reversible or irreversible. But for reversible processes, this restoration is made without leaving any net change on the surroundings, whereas for irreversible processes, the surroundings usually do some work on the system and therefore does not return to their original state.

Reversible processes actually do not occur in nature. They are merely *idealizations* of actual processes. Reversible processes can be approximated by actual devices, but they can never be achieved. That is, all the processes occurring in nature are irreversible. You may be wondering, then, *why* we are bothering with such fictitious processes. There are two reasons. First, they are easy to analyze, since a system passes through a series of equilibrium states during a reversible process; second, they serve as idealized models to which actual processes can be compared.

In daily life, the concepts of Mr. Right and Ms. Right are also idealizations, just like the concept of a reversible (perfect) process. People who insist on finding Mr. or Ms. Right to settle down are bound to remain Mr. or Ms. Single for the rest of their lives. The possibility of finding the perfect prospective mate is no higher than the possibility of finding a perfect (reversible) process. Likewise, a person who insists on perfection in friends is bound to have no friends.

Engineers are interested in reversible processes because work-producing devices such as car engines and gas or steam turbines *deliver the most work*, and work-consuming devices such as compressors, fans, and pumps *consume the least work* when reversible processes are used instead of irreversible ones (Fig. 6–31).

Reversible processes can be viewed as *theoretical limits* for the corresponding irreversible ones. Some processes are more irreversible than others. We may never be able to have a reversible process, but we can certainly approach it. The more closely we approximate a reversible process, the more work delivered by a work-producing device or the less work required by a work-consuming device.

The concept of reversible processes leads to the definition of the **second-law efficiency** for actual processes, which is the degree of approximation to the corresponding reversible processes. This enables us to compare the performance of different devices that are designed to do the same task on the basis of their efficiencies. The better the design, the lower the irreversibilities and the higher the second-law efficiency.

## Irreversibilities

The factors that cause a process to be irreversible are called **irreversibilities**. They include friction, unrestrained expansion, mixing of two fluids, heat transfer across a finite temperature difference, electric resistance, inelastic deformation of solids, and chemical reactions. The presence of any of these effects renders a process irreversible. A reversible process involves none of these. Some of the frequently encountered irreversibilities are discussed briefly below.

**Friction** is a familiar form of irreversibility associated with bodies in motion. When two bodies in contact are forced to move relative to each other (a piston in a cylinder, for example, as shown in Fig. 6–32), a friction force that opposes the motion develops at the interface of these two bodies, and some work is needed to overcome this friction force. The energy supplied as work is eventually converted to heat during the process and is transferred to the bodies in contact, as evidenced by a temperature rise at the interface. When the direction of the motion is reversed, the bodies are restored to their original position, but the interface does not cool, and heat is not converted back to work. Instead, more of the work is converted to heat while overcoming the friction forces that also oppose the reverse motion. Since the system (the moving bodies) and the surroundings cannot be returned to their original states, this process is irreversible. Therefore, any process that involves friction is irreversible. The larger the friction forces involved, the more irreversible the process is.

Friction does not always involve two solid bodies in contact. It is also encountered between a fluid and solid and even between the layers of a fluid moving at different velocities. A considerable fraction of the power produced by a car engine is used to overcome the friction (the drag force) between the air and the external surfaces of the car, and it eventually becomes part of the internal energy of the air. It is not possible to reverse

this process and recover that lost power, even though doing so would not violate the conservation of energy principle.

Another example of irreversibility is the **unrestrained expansion of a gas** separated from a vacuum by a membrane, as shown in Fig. 6–33. When the membrane is ruptured, the gas fills the entire tank. The only way to restore the system to its original state is to compress it to its initial volume, while transferring heat from the gas until it reaches its initial temperature. From the conservation of energy considerations, it can easily be shown that the amount of heat transferred from the gas equals the amount of work done on the gas by the surroundings. The restoration of the surroundings involves conversion of this heat completely to work, which would violate the second law. Therefore, unrestrained expansion of a gas is an irreversible process.

A third form of irreversibility familiar to us all is **heat transfer** through a finite temperature difference. Consider a can of cold soda left in a warm room (Fig. 6–34). Heat is transferred from the warmer room air to the cooler soda. The only way this process can be reversed and the soda restored to its original temperature is to provide refrigeration, which requires some work input. At the end of the reverse process, the soda will be restored to its initial state, but the surroundings will not be. The internal energy of the surroundings will increase by an amount equal in magnitude to the work supplied to the refrigerator. The restoration of the surroundings to the initial state can be done only by converting this excess internal energy completely to work, which is impossible to do without violating the second law. Since only the system, not both the system and the surroundings, can be restored to its initial condition, heat transfer through a finite temperature difference is an irreversible process.

Heat transfer can occur only when there is a temperature difference between a system and its surroundings. Therefore, it is physically impossible to have a reversible heat transfer process. But a heat transfer process becomes less and less irreversible as the temperature difference between the two bodies approaches zero. Then heat transfer through a differential temperature difference  $dT$  can be considered to be reversible. As  $dT$  approaches zero, the process can be reversed in direction (at least theoretically) without requiring any refrigeration. Notice that reversible heat transfer is a conceptual process and cannot be duplicated in the real world.

The smaller the temperature difference between two bodies, the smaller the heat transfer rate will be. Any significant heat transfer through a small temperature difference requires a very large surface area and a very long time. Therefore, even though approaching reversible heat transfer is desirable from a thermodynamic point of view, it is impractical and not economically feasible.

### **Corollaries of the Second Law**

There are many propositions that are derived from the second law. The corollaries of the second law are listed below:

Corollary 1—The Clausius statement of the second law.

Corollary 2, 3, 4—“Carnot Principles.”

Corollary 5—Establishes an absolute temperature scale independent of the thermometric substance.

Corollary 6—The Clausius inequality.

Corollary 7—Gives the definition of “entropy”.

Corollary 8—Discussion of the entropy of an isolated system.

**Corollary 1—The Clausius Statement**

**Corollary 2—Efficiency of the Reversible Engines**

There is no heat engine operating between a source and a sink that can have a greater efficiency than a reversible heat engine operating between the same two thermal reservoirs.

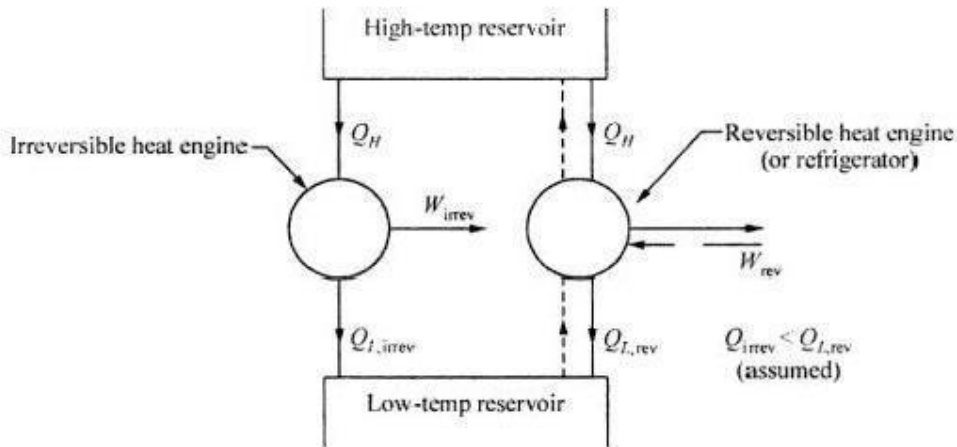

**Fig. 3.8** Reversible and irreversible engines.

Let us assume that the thermal efficiency of the irreversible engine,  $\eta_{th,irrev}$ , in Fig. 3.8 is greater than that of the reversible engine,  $\eta_{th,rev}$ . This assumption contradicts the first principle of Carnot, Corollary 2 of the second law. Hence,

Let us assume that the thermal efficiency of the irreversible engine,  $\eta_{th,irrev}$ , in Fig. 3.8 is greater than that of the reversible engine,  $\eta_{th,rev}$ . This assumption contradicts the first principle of Carnot, Corollary 2 of the second law. Hence,

$$\eta_{th,irrev} > \eta_{th,rev}$$

So, from Eq. (3.1) we can write

$$\left( \frac{Q_H - Q_L}{Q_H} \right)_{irrev} > \left( \frac{Q_H - Q_L}{Q_H} \right)_{rev}$$

But,

$$Q_H - Q_L = W_{net}$$

∴

$$\left( \frac{W_{net}}{Q_H} \right)_{irrev} > \left( \frac{W_{net}}{Q_H} \right)_{rev}$$

Since,

$$Q_{H,irrev} = Q_{H,rev}$$

$$\therefore (W_{\text{net}})_{\text{irrev}} > (W_{\text{net}})_{\text{rev}}$$

Now, consider that the reversible heat engine is reversed to operate as a refrigerator, which receives an input work  $W_{\text{rev}}$  and rejects heat to the high-temperature reservoir. As the refrigerator rejects heat  $Q_H$  to the high-temperature reservoir and the irreversible heat engine receives the same amount of heat from the same reservoir the net heat transfer from the reservoir is zero. Hence, instead of providing the reservoir the rejected heat  $Q_H$  from the refrigerator can be put directly to the irreversible heat engine. The resulting refrigerator–irreversible heat engine combination is depicted in Fig. 3.9. The combination will produce a net work equal to  $(W_{\text{irrev}} - W_{\text{rev}})$  and exchange heat with a single reservoir.

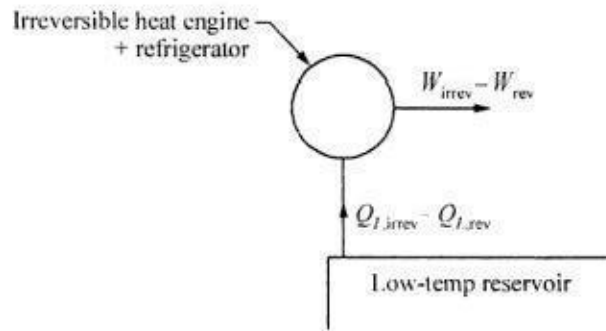

**Fig. 3.9** Combination of refrigerator and irreversible heat engine.

This is a clear violation of the Kelvin–Planck statement and gives rise to the perpetual motion machine of the second kind. Hence, our assumption that the efficiency of the irreversible engine is greater than the efficiency of the reversible engine is incorrect and the corollary is a valid statement.

### Corollary 3—Equality of Reversible Engines

According to the corollary, all reversible engines operating between the same temperature limits will have equal efficiency. As in this case, efficiency of one reversible engine cannot be greater than that of the other, the corollary is viable.

### Corollary 4—Efficiency of Reversible Engines and Characteristics of the Working Media

The efficiency of a reversible engine operating between two temperature limits is independent of the characteristics of the working medium and depends only on the temperature limits. Let a Carnot engine and a reversible engine operate between the same two reservoirs. Efficiency of a Carnot engine, from Eq. (3.5), is given by

$$\eta_{\text{Carnot}} = 1 - \frac{Q_L}{Q_H}$$

According to Corollary 3,

$$\eta_{\text{rev}} = \eta_{\text{Carnot}} = 1 - \frac{Q_L}{Q_H} = \phi(T_L, T_H) \quad (3.6)$$

### Corollary 7—Entropy

The Clausius inequality leads to a property of a system called *entropy* (see Fig. 3.11). The system undergoes a reversible process from state point 1 to 2, along path *A*, and let it complete the cycle following path *B*.

For a reversible cycle

$$\oint \frac{\delta Q}{T} = 0$$

$$\Rightarrow \int_{1A}^{2A} \frac{\delta Q}{T} + \int_{2B}^{1B} \frac{\delta Q}{T} = 0 \quad (3.17)$$

Now, let the system follows another reversible cycle 1A2C1. For this reversible cycle

$$\int_{1A}^{2A} \frac{\delta Q}{T} + \int_{2C}^{1C} \frac{\delta Q}{T} = 0 \quad (3.18)$$

Hence, the integrated term is remaining the same for all the reversible paths between 1 and 2. It is a function of the end states only, and is path independent. So we can call it a property. This property is called entropy and is designated  $S$ , with

$$dS = \left( \frac{\delta Q}{T} \right)_{\text{rev}} \quad (3.19)$$

Entropy is an extensive property of a system and it is also known as total entropy. Entropy per unit mass,  $s$ , is an intensive property.

Integration of Eq. (3.19) will give the change in  $S$  during a process.

$$\Delta S = S_2 - S_1 = \int_1^2 \left( \frac{\delta Q}{T} \right)_{\text{rev}} \quad (3.20)$$

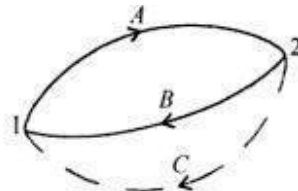

Fig. 3.12 One reversible and one irreversible cycle.

Now consider Fig. 3.12. Here the cycle 1A2B1 is reversible, but the path 2C1 being irreversible the cycle 1A2C1 is irreversible.

For the reversible cycle 1A2B1

$$\oint \frac{\delta Q}{T} = \int_{1A}^{2A} \frac{\delta Q}{T} + \int_{2B}^{1B} \frac{\delta Q}{T} = 0 \quad (3.21)$$

For the irreversible cycle 1A2C1, from the inequality of Clausius

$$\oint \frac{\delta Q}{T} = \int_{1A}^{2A} \frac{\delta Q}{T} + \int_{2C}^{1C} \frac{\delta Q}{T} < 0 \quad (3.22)$$

Subtracting Eq. (3.22) from Eq. (3.21) we get

$$\int_{2B}^{1B} \frac{\delta Q}{T} > \int_{2C}^{1C} \frac{\delta Q}{T}$$

But, path B is reversible and entropy is path independent.

$$\therefore \int_{2B}^{1B} \frac{\delta Q}{T} = \int_{2B}^{1B} dS = \int_{2C}^{1C} dS$$

Hence

$$\int_{2C}^{1C} dS > \int_{2C}^{1C} \frac{\delta Q}{T}$$

In general, the above equation can be modified as

$$dS \geq \frac{\delta Q}{T}$$

$$\text{or} \quad S_2 - S_1 \geq \int_1^2 \frac{\delta Q}{T} \quad (3.23)$$

For a reversible process,

$$dS = \frac{\delta Q}{T}$$

And for an irreversible process,

$$dS > \frac{\delta Q}{T}$$

So, entropy is an index of unavailability or degradation of energy. Heat flows, by nature, from hot to cold bodies, thus becoming degraded or less available. Energy going to sink becomes less available for work though most of it may be recovered by heat economy devices. This amount of unavailability is given by entropy. Generally we are concerned with change of entropy.

### The Principle of Increase of Entropy

Equation (3.23) is very important in the realm of thermodynamics.

Let us consider the entropy change of the universe when a system performs a reversible process. During any infinitesimal portion of this reversible process, let an amount of heat  $\delta Q$  is transferred from a reservoir to the system at a temperature  $T$ .

$$dS_{\text{system}} = +\frac{\delta Q}{T}$$

$$dS_{\text{reservoir}} = -\frac{\delta Q}{T}$$

Hence, 
$$dS_{\text{universe}} = dS_{\text{system}} + dS_{\text{reservoir}} = 0 \quad (3.24)$$

So, in the case of a reversible heat transfer, the change of entropy of the universe is zero. Obviously, if  $dQ$  is zero, the entropies of both the system and the surroundings remain unchanged. As the above remark holds good for any infinitesimal portion of the process, it should be true for the entire process as well.

Let us now consider an irreversible process. Consider a heat transfer  $\delta Q$  from a source at  $T_H$  to a sink at  $T_L$ . The source loses an amount of entropy  $\delta Q/T_H$  and sink gains  $\delta Q/T_L$ . But,  $T_H$  being greater than  $T_L$  there is a net gain in entropy, like

$$\begin{aligned} dS_{\text{universe}} &= dS_{\text{system}} + dS_{\text{surroundings}} \\ &= -\frac{\delta Q}{T_H} + \frac{\delta Q}{T_L} \\ &= \delta Q \left( \frac{1}{T_L} - \frac{1}{T_H} \right) > 0 \end{aligned}$$

Hence, an irreversible heat transfer leads to an increase in entropy. According to Lord Kelvin, the entropy increases continuously when spontaneous processes occur in nature. Clausius stated that the energy of the Universe remains constant and the entropy of the same increases towards the maximum.

Thus, the principle of increase of entropy can be stated as:

*Of all states at which the stored energy (for a simple system, stored energy can be replaced by internal energy) of the system is the same, the most stable state is the one that corresponds to the maximum entropy.*

### Corollary 8—Entropy of an Isolated System

Often the principle of the increase of entropy is stated in terms of an isolated system, a system in which there is no interaction between the system and its surroundings. In this case,

$$dS_{\text{isolated system}} \geq 0 \quad (3.26)$$

Since the system and its surroundings are two sub-systems of the isolated system,

$$dS_{\text{isolated system}} = dS_{\text{system}} + dS_{\text{surroundings}} = dS_{\text{gen}} \quad (3.27)$$

where  $dS_{\text{gen}}$  is called the *entropy generation* due to irreversibility. Since all real processes are irreversible, entropy generation is always positive. Practically, it is a non-zero quantity and process dependent. It is not a property of the system. For a reversible process it is zero. There should be effort to design a process that has the minimum entropy generation.

### The Increase of Entropy for Closed Systems

The increase in entropy for a closed system is the difference between the initial and final entropies of the system, as there is no mass flow across the boundary.

In this case

$$dS_{\text{gen}} = dS_{\text{system}} + dS_{\text{surroundings}} \geq 0 \quad \text{or} \quad S_{\text{gen}} = \Delta S_{\text{system}} + \Delta S_{\text{surroundings}} \geq 0 \quad (3.28)$$

where

$$\Delta S_{\text{system}} = (S_2 - S_1)_{\text{system}} = m(s_2 - s_1)$$

And

$$\Delta S_{\text{surroundings}} = \frac{Q_{\text{surroundings}}}{T_{\text{surroundings}}}$$

### The Increase of Entropy for Control Volumes

This is similar to a closed system, but there is mass flow across the boundary of the control volume.

The change in entropy of the control volume

$$\Delta S_{\text{cv}} = (S_2 - S_1)_{\text{cv}}$$

And

$$\Delta S_{\text{surroundings}} = \frac{Q_{\text{surroundings}}}{T_{\text{surroundings}}} + S_e - S_i$$

where the subscripts 1 and 2 indicate the initial and final states, respectively, in the control volume and the subscripts  $i$  and  $e$  denote the inlet and exit states of the control volume respectively.  $S_i$  is the total entropy transported into the control volume from the surroundings and  $S_e$  is the total entropy transported out of the control volume into the surroundings, with the mass leaving the control volume.

## THE CARNOT CYCLE

We mentioned earlier that heat engines are cyclic devices and that the working fluid of a heat engine returns to its initial state at the end of each cycle. Work is done by the working fluid during one part of the cycle and on the working fluid during another part. The difference between these two is the net work delivered by the heat engine. The efficiency of a heat-engine cycle greatly depends on how the individual processes that make up the cycle are executed. The net work, thus the cycle efficiency, can be maximized by using processes that require the least amount of work and deliver the most,

that is, by using *reversible processes*. Therefore, it is no surprise that the most efficient cycles are reversible cycles, that is, cycles that consist entirely of reversible processes.

Reversible cycles cannot be achieved in practice because the irreversibilities associated with each process cannot be eliminated. However, reversible cycles provide upper limits on the performance of real cycles. Heat engines and refrigerators that work on reversible cycles serve as models to which actual heat engines and refrigerators can be compared. Reversible cycles also serve as starting points in the development of actual cycles and are modified as needed to meet certain requirements.

Probably the best known reversible cycle is the **Carnot cycle**, first proposed in 1824 by French engineer Sadi Carnot. The theoretical heat engine that operates on the Carnot cycle is called the **Carnot heat engine**. The Carnot cycle is composed of four reversible processes—two isothermal and two adiabatic—and it can be executed either in a closed or a steady-flow system.

Consider a closed system that consists of a gas contained in an adiabatic piston-cylinder device, as shown in Fig. 6–37. The insulation of the cylinder head is such that it may be removed to bring the cylinder into contact with reservoirs to provide heat transfer. The four reversible processes that make up the Carnot cycle are as follows:

**Reversible Isothermal Expansion** (process 1-2,  $T_H = \text{constant}$ ). Initially (state 1), the temperature of the gas is  $T_H$  and the cylinder head is in close contact with a source at temperature  $T_H$ . The gas is allowed to expand slowly, doing work on the surroundings. As the gas expands, the temperature of the gas tends to decrease. But as soon as the temperature drops by an infinitesimal amount  $dT$ , some heat is transferred from the reservoir into the gas, raising the gas temperature to  $T_H$ . Thus, the gas temperature is kept constant at  $T_H$ . Since the temperature difference between the gas and the reservoir never exceeds a differential amount  $dT$ , this is a reversible heat transfer process. It continues until the piston reaches position 2. The amount of total heat transferred to the gas during this process is  $Q_H$ .

**Reversible Adiabatic Expansion** (process 2-3, temperature drops from  $T_H$  to  $T_L$ ). At state 2, the reservoir that was in contact with the cylinder head is removed and replaced by insulation so that the system becomes adiabatic. The gas continues to expand slowly, doing work on the surroundings until its temperature drops from  $T_H$  to  $T_L$  (state 3). The piston is assumed to be frictionless and the process to be quasi-equilibrium, so the process is reversible as well as adiabatic.

**Reversible Isothermal Compression** (process 3-4,  $T_L = \text{constant}$ ). At state 3, the insulation at the cylinder head is removed, and the cylinder is brought into contact with a sink at temperature  $T_L$ . Now the piston is pushed inward by an external force, doing work on the gas. As the gas is compressed, its temperature tends to rise. But as soon as it rises by an infinitesimal amount  $dT$ , heat is transferred from the gas to the sink, causing the gas temperature to drop to  $T_L$ . Thus, the gas temperature remains constant at  $T_L$ . Since the temperature difference between the gas and the sink never exceeds a differential amount  $dT$ , this is a reversible

heat transfer process. It continues until the piston reaches state 4. The amount of heat rejected from the gas during this process is  $Q_L$ .

**Reversible Adiabatic Compression** (process 4-1, temperature rises from  $T_L$  to  $T_H$ ). State 4 is such that when the low-temperature reservoir is removed, the insulation is put back on the cylinder head, and the gas is compressed in a reversible manner, the gas returns to its initial state (state 1). The temperature rises from  $T_L$  to  $T_H$  during this reversible adiabatic compression process, which completes the cycle.

The  $P$ - $V$  diagram of this cycle is shown in Fig. 6-38. Remembering that on a  $P$ - $V$  diagram the area under the process curve represents the boundary work for quasi-equilibrium (internally reversible) processes, we see that the area under curve 1-2-3 is the work done by the gas during the expansion part of the cycle, and the area under curve 3-4-1 is the work done on the gas during the compression part of the cycle. The area enclosed by the path of the cycle (area 1-2-3-4-1) is the difference between these two and represents the net work done during the cycle.

Notice that if we acted stingily and compressed the gas at state 3 adiabatically instead of isothermally in an effort to save  $Q_L$ , we would end up back at state 2, retracing the process path 3-2. By doing so we would save  $Q_L$ , but we would not be able to obtain any net work output from this engine. This illustrates once more the necessity of a heat engine exchanging heat with at least two reservoirs at different temperatures to operate in a cycle and produce a net amount of work.

The Carnot cycle can also be executed in a steady-flow system. It is discussed in later chapters in conjunction with other power cycles.

Being a reversible cycle, the Carnot cycle is the most efficient cycle operating between two specified temperature limits. Even though the Carnot cycle cannot be achieved in reality, the efficiency of actual cycles can be improved by attempting to approximate the Carnot cycle more closely.

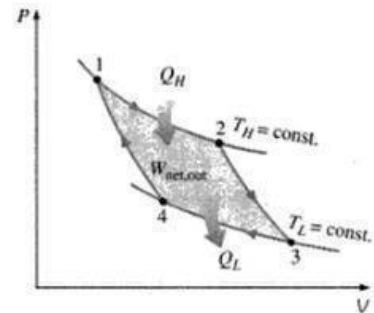

FIGURE 6-38  
 $P$ - $V$  diagram of the Carnot cycle.

## THE THERMODYNAMIC TEMPERATURE SCALE

A temperature scale that is independent of the properties of the substances that are used to measure temperature is called a **thermodynamic temperature scale**. Such a temperature scale offers great conveniences in thermodynamic calculations, and its derivation is given below using some reversible heat engines.

The second Carnot principle discussed in Section 6-8 states that all reversible heat engines have the same thermal efficiency when operating between the same two reservoirs (Fig. 6-42). That is, the efficiency of a reversible engine is independent of the working fluid employed and its properties, the way the cycle is executed, or the type of reversible engine used. Since energy reservoirs are characterized by their temperatures, the thermal efficiency of reversible heat engines is a function of the reservoir temperatures only. That is,

$$\eta_{th,rev} = g(T_H, T_L)$$

or

$$\frac{Q_H}{Q_L} = f(T_H, T_L) \quad (6-13)$$

since  $\eta_{th} = 1 - Q_L/Q_H$ . In these relations  $T_H$  and  $T_L$  are the temperatures of the high- and low-temperature reservoirs, respectively.

The functional form of  $f(T_H, T_L)$  can be developed with the help of the three reversible heat engines shown in Fig. 6–43. Engines A and C are supplied with the same amount of heat  $Q_1$  from the high-temperature reservoir at  $T_1$ . Engine C rejects  $Q_3$  to the low-temperature reservoir at  $T_3$ . Engine B receives the heat  $Q_2$  rejected by engine A at temperature  $T_2$  and rejects heat in the amount of  $Q_3$  to a reservoir at  $T_3$ .

The amounts of heat rejected by engines B and C must be the same since engines A and B can be combined into one reversible engine operating between the same reservoirs as engine C and thus the combined engine will

have the same efficiency as engine C. Since the heat input to engine C is the same as the heat input to the combined engines A and B, both systems must reject the same amount of heat.

Applying Eq. 6–13 to all three engines separately, we obtain

$$\frac{Q_1}{Q_2} = f(T_1, T_2), \quad \frac{Q_2}{Q_3} = f(T_2, T_3), \quad \text{and} \quad \frac{Q_1}{Q_3} = f(T_1, T_3)$$

Now consider the identity

$$\frac{Q_1}{Q_3} = \frac{Q_1}{Q_2} \frac{Q_2}{Q_3}$$

which corresponds to

$$f(T_1, T_3) = f(T_1, T_2) \cdot f(T_2, T_3)$$

A careful examination of this equation reveals that the left-hand side is a function of  $T_1$  and  $T_3$ , and therefore the right-hand side must also be a function of  $T_1$  and  $T_3$  only, and not  $T_2$ . That is, the value of the product on the right-hand side of this equation is independent of the value of  $T_2$ . This condition will be satisfied only if the function  $f$  has the following form:

$$f(T_1, T_2) = \frac{\phi(T_1)}{\phi(T_2)} \quad \text{and} \quad f(T_2, T_3) = \frac{\phi(T_2)}{\phi(T_3)}$$

so that  $\phi(T_2)$  will cancel from the product of  $f(T_1, T_2)$  and  $f(T_2, T_3)$ , yielding

$$\frac{Q_1}{Q_3} = f(T_1, T_3) = \frac{\phi(T_1)}{\phi(T_3)} \quad (6-14)$$

This relation is much more specific than Eq. 6-13 for the functional form of  $Q_1/Q_3$  in terms of  $T_1$  and  $T_3$ .

For a reversible heat engine operating between two reservoirs at temperatures  $T_H$  and  $T_L$ , Eq. 6-14 can be written as

$$\frac{Q_H}{Q_L} = \frac{\phi(T_H)}{\phi(T_L)} \quad (6-15)$$

This is the only requirement that the second law places on the ratio of heat transfers to and from the reversible heat engines. Several functions  $\phi(T)$  satisfy this equation, and the choice is completely arbitrary. Lord Kelvin first proposed taking  $\phi(T) = T$  to define a thermodynamic temperature scale as (Fig. 6-44)

$$\left(\frac{Q_H}{Q_L}\right)_{\text{rev}} = \frac{T_H}{T_L} \quad (6-16)$$

This temperature scale is called the **Kelvin scale**, and the temperatures on this scale are called **absolute temperatures**. On the Kelvin scale, the temperature ratios depend on the ratios of heat transfer between a reversible heat engine and the reservoirs and are independent of the physical properties of any substance. On this scale, temperatures vary between zero and infinity.

The thermodynamic temperature scale is not completely defined by Eq. 6-16 since it gives us only a ratio of absolute temperatures. We also need to know the magnitude of a kelvin. At the International Conference on

Weights and Measures held in 1954, the triple point of water (the state at which all three phases of water exist in equilibrium) was assigned the value 273.16 K (Fig. 6-45). The *magnitude of a kelvin* is defined as 1/273.16 of the temperature interval between absolute zero and the triple-point temperature of water. The magnitudes of temperature units on the Kelvin and Celsius scales are identical ( $1 \text{ K} \equiv 1^\circ\text{C}$ ). The temperatures on these two scales differ by a constant 273.15:

$$T(^{\circ}\text{C}) = T(\text{K}) - 273.15 \quad (6-17)$$

Even though the thermodynamic temperature scale is defined with the help of the reversible heat engines, it is not possible, nor is it practical, to actually operate such an engine to determine numerical values on the absolute temperature scale. Absolute temperatures can be measured accurately by other means, such as the constant-volume ideal-gas thermometer together with extrapolation techniques as discussed in Chap. 1. The validity of Eq. 6-16 can be demonstrated from physical considerations for a reversible cycle using an ideal gas as the working fluid.

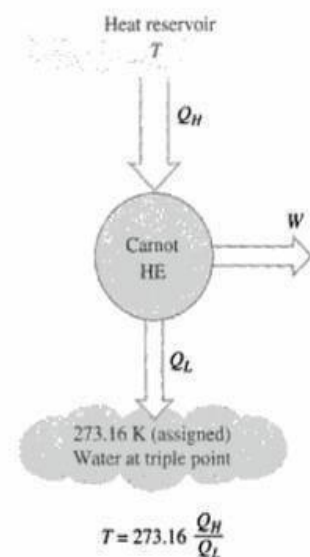

## THE CARNOT HEAT ENGINE

The hypothetical heat engine that operates on the reversible Carnot cycle is called the **Carnot heat engine**. The thermal efficiency of any heat engine, reversible or irreversible, is given by Eq. 6-6 as

$$\eta_{th} = 1 - \frac{Q_L}{Q_H}$$

where  $Q_H$  is heat transferred to the heat engine from a high-temperature reservoir at  $T_H$ , and  $Q_L$  is heat rejected to a low-temperature reservoir at  $T_L$ . For reversible heat engines, the heat transfer ratio in the above relation can be replaced by the ratio of the absolute temperatures of the two reservoirs, as given by Eq. 6-16. Then the efficiency of a Carnot engine, or any reversible heat engine, becomes

$$\eta_{th,rev} = 1 - \frac{T_L}{T_H} \quad (6-18)$$

This relation is often referred to as the **Carnot efficiency**, since the Carnot heat engine is the best known reversible engine. *This is the highest efficiency a heat engine operating between the two thermal energy reservoirs at temperatures  $T_L$  and  $T_H$  can have* (Fig. 6-46). All irreversible (i.e., actual) heat engines operating between these temperature limits ( $T_L$  and  $T_H$ ) have lower efficiencies. An actual heat engine cannot reach this maximum theoretical efficiency value because it is impossible to completely eliminate all the irreversibilities associated with the actual cycle.

Note that  $T_L$  and  $T_H$  in Eq. 6-18 are *absolute temperatures*. Using  $^{\circ}\text{C}$  for temperatures in this relation gives results grossly in error.

The thermal efficiencies of actual and reversible heat engines operating between the same temperature limits compare as follows (Fig. 6-47):

$$\eta_{th} \begin{cases} < \eta_{th,rev} & \text{irreversible heat engine} \\ = \eta_{th,rev} & \text{reversible heat engine} \\ > \eta_{th,rev} & \text{impossible heat engine} \end{cases} \quad (6-19)$$

$$\eta = 1 - \frac{Q_L}{Q_H}$$

FIGURE 6-45

A conceptual experimental setup to determine thermodynamic temperatures on the Kelvin scale by measuring heat transfers  $Q_H$  and  $Q_L$ .

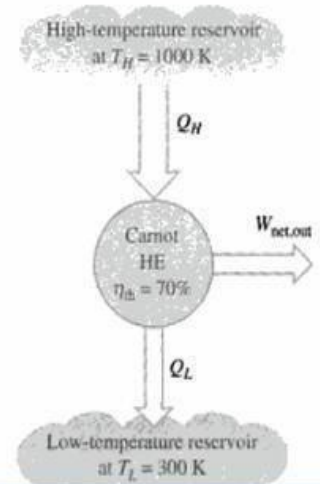

### Thermodynamic Relations

Consider a simple compressible substance without any motion or gravitational effects. Then the first law for a change of state can be obtained as

$$\delta Q = dU + \delta W$$

For a reversible process of a simple compressible substance we get

$$\delta Q = T dS \text{ and } \delta W = p dV$$

Substituting these relations into the first-law equation we have

$$T dS = dU + p dV \quad (3.85)$$

This is one of the two important relations.

Again, enthalpy is defined as

$$H = U + pV$$

Differentiating we get

$$dH = dU + p dV + V dp$$

Using Eq. (3.85) we can write

$$dH = T dS + V dp$$

or

$$T dS = dH - V dp \quad (3.86)$$

This is the second important relation.

On unit mass basis

$$T ds = du + p dv \quad (3.87a)$$

And

$$T ds = dh - v dp \quad (3.87b)$$

On mole basis

$$T d\bar{s} = d\bar{u} + p d\bar{v} \quad (3.88a)$$

And

$$T d\bar{s} = d\bar{h} - \bar{v} dp \quad (3.88b)$$

## Maxwell's Relations

$$\Delta s = C_p \ln \left( \frac{T_2}{T_1} \right) - R \ln \left( \frac{P_2}{P_1} \right)$$

$$\Delta s = C_v \ln \left( \frac{T_2}{T_1} \right) + R \ln \left( \frac{v_2}{v_1} \right)$$

By devising a different reversible path, connecting the final state with the initial state, the entropy change for an ideal gas can be estimated by the following equation also.

$$\Delta s = C_p \ln \left( \frac{v_2}{v_1} \right) + C_v \ln \left( \frac{P_2}{P_1} \right) \quad (8.1)$$

When an ideal gas undergoes a change of state from  $P_1, v_1, T_1$  to  $P_2, v_2, T_2$ , the entropy change of the gas can be estimated by any of the above three equations. Depending on the independent variables, we choose the appropriate equation for estimating  $\Delta s$ . However, these relations can be used only for an ideal gas and not for any other substance.

The above equations express the entropy in terms of two independent variables which can be easily measured. Since entropy plays an important role in thermodynamic analysis of processes, a knowledge of the estimation of entropy change of a substance is essential. A differential change in the entropy associated with the differential change in the independent variables can be expressed as:

$$s = s(T, P)$$

$$ds = \left( \frac{\partial s}{\partial T} \right)_P dT + \left( \frac{\partial s}{\partial P} \right)_T dP \quad (8.2)$$

$$s = s(T, v)$$

$$ds = \left( \frac{\partial s}{\partial T} \right)_v dT + \left( \frac{\partial s}{\partial v} \right)_T dv \quad (8.3)$$

$$s = s(P, v)$$

$$ds = \left( \frac{\partial s}{\partial P} \right)_v dP + \left( \frac{\partial s}{\partial v} \right)_P dv \quad (8.4)$$

These relations can be integrated to obtain  $\Delta s$ . To integrate these relations, a knowledge of the six partial derivatives of entropy, namely,  $(\partial s/\partial T)_P$ ;  $(\partial s/\partial T)_v$ ;  $(\partial s/\partial P)_T$ ;  $(\partial s/\partial P)_v$ ;  $(\partial s/\partial v)_T$  and  $(\partial s/\partial v)_P$ , is essential. Of these, the partial derivatives of entropy with respect to temperature are related to the specific heats  $C_p$  and  $C_v$  by the equations:

$$C_p = T \left( \frac{\partial s}{\partial T} \right)_P \quad (8.5)$$

$$C_v = T \left( \frac{\partial s}{\partial T} \right)_v \quad (8.6)$$

The remaining four partial derivatives of entropy are expressed in terms of the measurable quantities by equations known as the Maxwell relations and are discussed below.

Combining the first and second laws of thermodynamics, we get

$$du = Tds - Pdv$$

Since  $u$  is a property, its differential must be exact. Applying the criterion for exactness, we get

$$\left( \frac{\partial T}{\partial v} \right)_s = - \left( \frac{\partial P}{\partial s} \right)_v \quad (8.7)$$

The term  $(\partial T/\partial v)_s$  represents the slope of an isentropic curve on a  $T-v$  diagram and this slope can be easily measured or estimated. This is related to the partial derivative of entropy with respect to pressure at constant volume. Therefore, Eq. (8.7) is a Maxwell relation.

Since  $h = u + Pv$ , or  $H = U + PV$ , we get

$$dh = du + Pdv + vdP \quad \text{or} \quad dH = dU + Pdv + VdP \quad (8.8)$$

Substituting Eq. (7.104) in Eq. (8.8), we get

$$dh = Tds + vdP \quad \text{or} \quad dH = TdS + VdP \quad (8.9)$$

We shall define two other thermodynamic properties of matter. The Helmholtz function  $a$  or  $A$  is defined as

$$a = u - Ts \quad \text{or} \quad A = U - TS \quad (8.10)$$

Then

$$dA = dU - Tds - SdT \quad \text{or} \quad da = du - Tds - sdT \quad (8.11)$$

Substituting Eq. (7.104) in Eq. (8.11), we get

$$dA = -PdV - SdT \quad \text{or} \quad da = -Pdv - sdT \quad (8.12)$$

The Gibbs free energy  $G$  or  $g$  is defined as

$$G = H - TS \quad \text{or} \quad g = h - Ts \quad (8.13)$$

Then

$$dG = dH - TdS - SdT \quad \text{or} \quad dg = dh - Tds - sdT \quad (8.14)$$

Substituting for  $dH$  from Eq. (8.9) in Eq. (8.14), we get

$$dG = -SdT + VdP \quad \text{or} \quad dg = -sdT + vdP \quad (8.15)$$

Note that the independent variables of  $U, H, A$  and  $G$  include  $P, v, T$  and  $s$  only. The equations (8.9), (8.12) and (8.15) are sometimes referred to as the *Gibbsian Equations*. Applying the criterion for exactness to Eqs. (8.9), (8.12) and (8.15), we get

$$\left(\frac{\partial T}{\partial P}\right)_s = \left(\frac{\partial v}{\partial s}\right)_P \quad (8.16)$$

$$\left(\frac{\partial P}{\partial T}\right)_v = \left(\frac{\partial s}{\partial v}\right)_T \quad (8.17)$$

$$\left(\frac{\partial s}{\partial P}\right)_T = -\left(\frac{\partial v}{\partial T}\right)_P \quad (8.18)$$

The Eqs. (8.7) and (8.16)–(8.18) are the well known Maxwell relations.

### Third law of thermodynamics - the Nernst-Planck postulate

A very important consideration in thermodynamics concerns the meaning of the zero on the absolute scale of temperature, i.e 0 K. Though the full significance of this issue can only be unravelled through considerations of *Quantum Statistical Mechanics*, thermodynamics comes with very strong pointers that 0 K is indeed a very special temperature.

A practical question that first comes to mind is whether this temperature is physically realizable, and if so, how? A somewhat related question is whether its existence is in conformity with the first and second laws of thermodynamics. Let us begin by recounting an objection to absolute zero that would be the first reaction by many. This is based on the premise that a Carnot cycle operating between 0 K and any other T, would be a *perfect heat engine* in the sense that its efficiency  $\eta = 1 - \frac{0}{T} = 1!$  This would most directly contradict the Kelvin postulate and hence the second law.

Therefore, if the isothermal variation of entropy *vanishes* at absolute zero, one can not have two distinct adiabats intersecting the  $T = 0$  isotherm, and no Carnot cycle can be operated, removing that particular objection to absolute zero. But evading inconsistency with second law by taking refuge under the assumption of a vanishing  $\left(\frac{\partial S}{\partial \xi}\right)_{T=0}$ , lands one in a different kind of difficulty. That difficulty is that when  $\left(\frac{\partial S}{\partial \xi}\right)_{T=0} = 0$ , *absolute zero is simply unattainable!* So there are two *logically distinct* aspects to the absolute zero issue; one being some system already existing in it, and the other being the attainability of absolute zero from an initial  $T \neq 0K$ .

**Q6.1** An inventor claims to have developed an engine that takes in 105 MJ at a temperature of 400 K, rejects 42 MJ at a temperature of 200 K, and delivers 15 kWh of mechanical work. Would you advise investing money to put this engine in the market?

(Ans. No)

**Solution:** Maximum thermal efficiency of his engine possible

$$\eta_{\max} = 1 - \frac{200}{400} = 50\%$$

$\therefore$  That engine and deliver output =  $\eta \times$  input

$$\begin{aligned} &= 0.5 \times 105 \text{ MJ} \\ &= 52.5 \text{ MJ} = 14.58 \text{ kWh} \end{aligned}$$

As he claims that his engine can deliver more work than ideally possible so I would not advise to investing money.

**Q6.2** If a refrigerator is used for heating purposes in winter so that the atmosphere becomes the cold body and the room to be heated becomes the hot body, how much heat would be available for heating for each kW input to the driving motor? The COP of the refrigerator is 5, and the electromechanical efficiency of the motor is 90%. How does this compare with resistance heating?

(Ans. 5.4 kW)

**Solution:** 
$$\text{COP} = \frac{\text{desired effect}}{\text{input}}$$

$$(\text{COP})_{\text{ref.}} = (\text{COP})_{\text{H.P.}} - 1$$

$$\text{or } 6 = \frac{H}{W} \qquad \therefore (\text{COP})_{\text{H.P.}} = 6$$

$$\text{So input (W)} = \frac{H}{6}$$

But motor efficiency 90% so

$$\text{Electrical energy require (E)} = \frac{W}{0.9} = \frac{H}{0.9 \times 6}$$

$$= 0.1852 H$$

$$= 18.52\% \text{ of Heat (direct heating)}$$

$$H = \frac{100}{18.52} \frac{\text{kW}}{\text{kW of work}} = 5.3995 \text{ kW}$$

**EXAMPLE** Calculate the entropy change when 1 kg nitrogen is changed from 300 K and 1 bar to 500 K and 3 bar. For nitrogen,  $C_p = 1.0416 \text{ kJ/ kg K}$ . Assume that nitrogen behaves like an ideal gas.

**SOLUTION** The entropy change of an ideal gas is given by

$$\Delta s = C_p \ln(T_2/T_1) - R \ln(P_2/P_1)$$

For nitrogen,

$$R = \frac{R_u}{M} = \frac{8.314 \times 10^3}{28}$$

$$= 0.2969 \text{ kJ/kg K}$$

Therefore,

$$\Delta s = 1.0416 \times 10^3 \ln(500/300) - 0.2969 \times 10^3 \ln(3/1)$$

$$= 0.2059 \text{ kJ/kg K}$$

**Example**

- (a) Air at 30 °C and 1 bar is compressed to a pressure of 5 bar in a SSSF reversible adiabatic process. It is then throttled back to the initial pressure of 1 bar. Show the two processes on  $T-s$  and  $p-v$  diagrams, and calculate the work done and net change in entropy of the universe per kg of air. Explain the significance of the result.
- (b) If the air is now restored to the initial state completing a cycle, estimate the net work done and heat transfer. Assuming the temperature of the surroundings as 25 °C, determine the net change in the entropy of the universe for the complete cycle per kg of air, and explain the significance of the result.

(a) The processes are shown in Fig. 6.56.

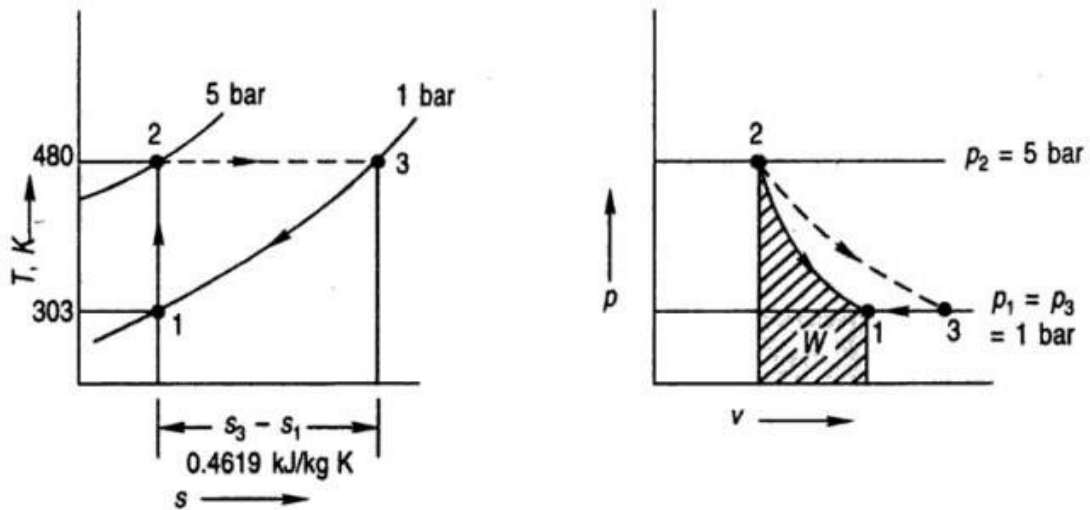

Fig. 6.56 Figure for Example 6.21

Temperature after reversible adiabatic compression

$$T_2 = T_1 \left( \frac{P_2}{P_1} \right)^{\frac{k-1}{k}} = 303 (5)^{0.2857} = 480 \text{ K (207 °C)}$$

$$T_2 = T_1 \left( \frac{P_2}{P_1} \right)^{\frac{k-1}{k}} = 303 (5)^{0.2857} = 480 \text{ K (207 } ^\circ\text{C)}$$

Work of reversible adiabatic compression

$${}_1w_2 = (h_2 - h_1) = C_{p_0} (T_2 - T_1) = 1.0035 (480 - 313) = 177 \text{ kJ/kg}$$

Entropy change of air during compression,  $s_2 - s_1$ , is zero. Entropy change of air during throttling ( $T_3 = T_2$ ) is

$$s_3 - s_2 = -R \ln \frac{P_3}{P_2} = -0.287 \ln \left( \frac{1}{5} \right) = 0.4619 \text{ kJ/kg K}$$

Net entropy change of air

$$s_3 - s_1 = s_3 - s_2 = 0.4619 \text{ kJ/kg K}$$

Entropy change of surroundings is zero since there is no heat transfer.

Net entropy change of universe

$$\Delta S_{\text{universe}} = \Delta S_{\text{air}} = 0.4619 \text{ kJ/kg K}$$

During reversible adiabatic compression, 177 kJ of work per kg of air was done by the surroundings on the control volume. During irreversible throttling process, pressure dropped back to 1 bar, and the volume increased without extracting any work from the control volume. Thus, the work done during the reversible adiabatic compression process 1-2 was wasted in the irreversible throttling process 2-3. Surroundings is, therefore, a loser of 177 kJ of work and the entropy of the universe increases by 0.4619 kJ/K per kg of air.

(b) If the air is restored from 3 to the initial state 1, the cycle is completed. Then, for the working substance

$$\Delta S_{\text{system}} = 0$$

Process 3 to 1 is a constant pressure cooling process. No work is done in this flow process since  $-\int v dp = 0$ . However, heat is rejected to the surroundings which is given by

$$\begin{aligned} {}_3q_1 &= C_{p_0} (T_1 - T_3) = Q_{\text{surr}} \\ &= 1.0035 (480 - 303) = 177 \text{ kJ/kg} \end{aligned}$$

Increase in entropy of the surroundings

$$\Delta S_{\text{surr}} = \frac{Q}{T_0} = \frac{177}{298} = 0.594 \text{ kJ/K}$$

Increase in entropy of the universe

$$\Delta S_{\text{universe}} = \Delta S_{\text{system}} + \Delta S_{\text{surr}} = 0.594 \text{ kJ/K}$$

Thus, when the cycle is completed, the surroundings is a net loser of more valuable form of energy, that is, work of an amount equal to 177 kJ, and net gainer of waste heat of the same amount at the temperature of the surroundings itself. Further we see that the entropy of the universe increases by 0.594 kJ/kg K net as a result of the introduction of the irreversible throttling process.

**Note:** It is seen that the lost work is given by

$$LW = I = T_0 \Delta S = 298(0.594) = 177 \text{ kJ}$$

**Example 6.1** A cyclic heat engine operates between a source temperature of 800°C and a sink temperature of 30°C. What is the least rate of heat rejection per kW net output of the engine?

**Solution** For a reversible engine, the rate of heat rejection will be minimum (Fig. Ex. 6.1).

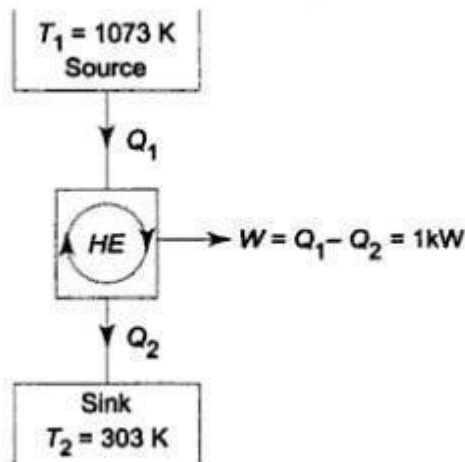

Fig. Ex. 6.1

$$\eta_{\text{max}} = \eta_{\text{rev}} = 1 - \frac{T_2}{T_1}$$

$$= 1 - \frac{30 + 273}{800 + 273}$$

$$= 1 - 0.282 = 0.718$$

Now  $\frac{W_{\text{net}}}{Q_1} = \eta_{\text{max}} = 0.718$

$\therefore Q_1 = \frac{1}{0.718} = 1.392 \text{ kW}$

Now  $Q_2 = Q_1 - W_{\text{net}} = 1.392 - 1$   
 $= 0.392 \text{ kW}$

This is the least rate of heat rejection.

Which is the more effective way to increase the efficiency of a Carnot engine: to increase  $T_1$ , keeping  $T_2$  constant; or to decrease  $T_2$ , keeping  $T_1$  constant?

*Solution* The efficiency of a Carnot engine is given by

$$\eta = 1 - \frac{T_2}{T_1}$$

If  $T_2$  is constant

$$\left( \frac{\partial \eta}{\partial T_1} \right)_{T_2} = \frac{T_2}{T_1^2}$$

As  $T_1$  increases,  $\eta$  increases, and the slope  $\left( \frac{\partial \eta}{\partial T_1} \right)_{T_2}$  decreases (Fig. Ex. 6.4.1).

If  $T_1$  is constant,

$$\left( \frac{\partial \eta}{\partial T_2} \right)_{T_1} = - \frac{1}{T_1}$$

As  $T_2$  decreases,  $\eta$  increases, but the slope  $\left( \frac{\partial \eta}{\partial T_2} \right)_{T_1}$  remains constant (Fig. Ex. 6.4.2).

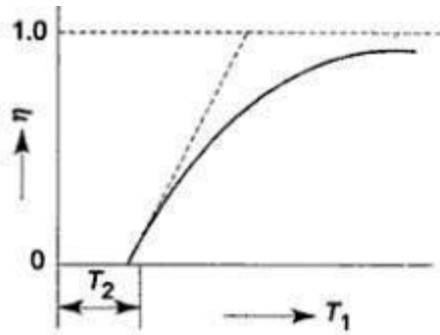

Fig. Ex. 6.4.1

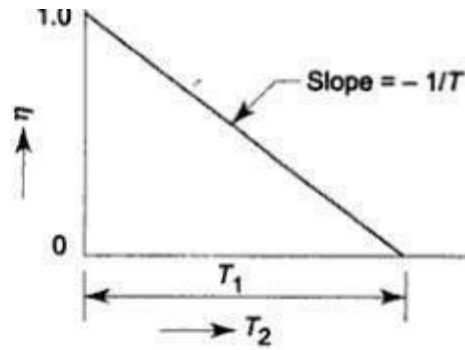

Fig. Ex. 6.4.2

Also 
$$\left(\frac{\partial \eta}{\partial T_1}\right)_{T_2} = \frac{T_2}{T_1^2} \text{ and } \left(\frac{\partial \eta}{\partial T_2}\right)_{T_1} = -\frac{T_1}{T_1^2}$$

Since 
$$T_1 > T_2, \left(\frac{\partial \eta}{\partial T_2}\right)_{T_1} > \left(\frac{\partial \eta}{\partial T_1}\right)_{T_2}$$

So, the more effective way to increase the efficiency is to decrease  $T_2$ .  
Alternatively, let  $T_2$  be decreased by  $\Delta T$  with  $T_1$  remaining the same

$$\eta_1 = 1 - \frac{T_2 - \Delta T}{T_1}$$

If  $T_1$  is increased by the same  $\Delta T$ ,  $T_2$  remaining the same

$$\eta_2 = 1 - \frac{T_2}{T_1 + \Delta T}$$

Then

$$\begin{aligned} \eta_1 - \eta_2 &= \frac{T_2}{T_1 + \Delta T} - \frac{T_2 - \Delta T}{T_1} \\ &= \frac{(T_1 - T_2)\Delta T + (\Delta T)^2}{T_1(T_1 + \Delta T)} \end{aligned}$$

Since  $T_1 > T_2, (\eta_1 - \eta_2) > 0$

The more effective way to increase the cycle efficiency is to decrease  $T_2$ .

**Example** A fluid undergoes a reversible adiabatic compression from 0.5 MPa, 0.2 m<sup>3</sup> to 0.05 m<sup>3</sup> according to the law,  $pv^{1.3} = \text{constant}$ . Determine the change in enthalpy, internal energy and entropy, and the heat transfer and work transfer during the process.

**Solution**

$$TdS = dH - Vdp$$

For the reversible adiabatic process (Fig. Ex. 7.7)

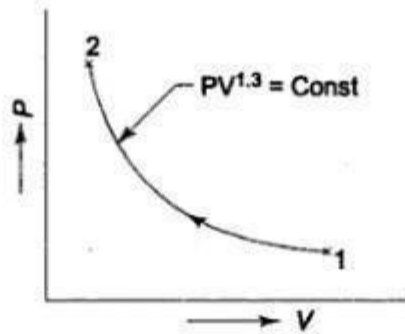

Fig. Ex. 7.7

$$dH = Vdp$$

$$p_1 = 0.5 \text{ MPa}, V_1 = 0.2 \text{ m}^3$$

$$V_2 = 0.05 \text{ m}^3, p_1 V_1^n = p_2 V_2^n$$

∴

$$p_2 = p_1 \left( \frac{V_1}{V_2} \right)^n$$

$$= 0.5 \times \left( \frac{0.20}{0.05} \right)^{1.3} \text{ MPa}$$

$$= 0.5 \times 6.061 \text{ MPa}$$

$$= 3.0305 \text{ MPa}$$

$$p_1 V_1^n = p V^n$$

$$V = \left( \frac{p_1 V_1^n}{p} \right)^{1/n}$$

$$\int_{H_1}^{H_2} dH = \int_{p_1}^{p_2} V dp$$

$$H_2 - H_1 = \int_{p_1}^{p_2} \left[ \left( \frac{p_1 V_1^n}{p} \right)^{1/n} \right] dp$$

$$\begin{aligned}
 &= (p_1 V_1^n)^{1/n} \left( \frac{p_1^{1-1/n} - p_1^{1-n/n}}{1 - 1/n} \right) \\
 &= \frac{n(p_2 V_2 - p_1 V_1)}{n-1} \\
 &= \frac{1.3(3030.5 \times 0.05 - 500 \times 0.2)}{1.3-1} \\
 &= 223.3 \text{ kJ}
 \end{aligned}$$

$$\begin{aligned}
 H_2 - H_1 &= (U_2 + p_2 V_2) - (U_1 + p_1 V_1) \\
 &= (U_2 - U_1) + (p_2 V_2 - p_1 V_1)
 \end{aligned}$$

$$\begin{aligned}
 U_2 - U_1 &= (H_2 - H_1) - (p_2 V_2 - p_1 V_1) \\
 &= 223.3 - 51.53 \\
 &= 171.77 \text{ kJ}
 \end{aligned}$$

Ans.

$$S_2 - S_1 = 0$$

Ans.

$$Q_{1-2} = 0$$

Ans.

$$Q_{1-2} = U_2 - U_1 + W_{1-2}$$

$$W_{1-2} = U_1 - U_2 = -171.77 \text{ kJ}$$

Ans.

**Example** Air is flowing steadily in an insulated duct. The pressure and temperature measurements of the air at two stations *A* and *B* are given below. Establish the direction of the flow of air in the duct. Assume that for air, specific heat  $c_p$  is constant at 1.005 kJ/kg K,  $h = c_p T$ , and  $\frac{v}{T} = \frac{0.287}{p}$ , where  $p$ ,  $v$  and  $T$  are pressure (in kPa), volume (in m<sup>3</sup>/kg) and temperature (in K) respectively.

	Station A	Station B
Pressure	130 kPa	100 kPa
Temperature	50°C	13°C

**Solution** From property relation

$$Tds = dh - vdp$$

$$ds = \frac{dh}{T} - v \frac{dp}{T}$$

For two states at *A* and *B* the entropy change of the system

$$\int_{s_A}^{s_B} ds = \int_{T_A}^{T_B} \frac{c_p dT}{T} - \int_{p_A}^{p_B} 0.287 \frac{dp}{p}$$

$$\begin{aligned}
 \therefore s_B - s_A &= 1.005 \ln \frac{T_B}{T_A} - 0.287 \ln \frac{p_B}{p_A} \\
 &= 1.005 \ln \frac{273 + 13}{273 + 50} - 0.287 \ln \frac{100}{130}
 \end{aligned}$$

$$\begin{aligned}
 &= -0.1223 + 0.0753 \\
 &= -0.047 \text{ kJ/kg K} \\
 (\Delta S)_{\text{system}} &= -0.047 \text{ kJ/kg K}
 \end{aligned}$$

Since the duct is insulated  $(\Delta S)_{\text{surr}} = 0$

$$(\Delta S)_{\text{univ}} = -0.047 \text{ kJ/kg K}$$

This is impossible. So the flow must be from *B* to *A*.

**Example 7.9** A hypothetical device is supplied with 2 kg/s of air at 4 bar, 300 K. Two separate streams of air leave the device, as shown in figure below. Each stream is at an ambient pressure of 1 bar, and the mass flow rate is the same for both streams. One of the exit streams is said to be at 330 K while the other is at 270 K. The ambient temperature is at 300 K. Determine whether such a device is possible.

*Solution* The entropy generation rate for the control volume (Fig. Ex. 7.9) is

$$\begin{aligned}
 \dot{S}_{\text{gen}} &= \sum \dot{m}_e s_e - \sum \dot{m}_i s_i \\
 &= \dot{m}_2 s_2 + \dot{m}_3 s_3 - \dot{m}_1 s_1 \\
 &= \dot{m}_2 s_2 + \dot{m}_3 s_3 - (\dot{m}_2 + \dot{m}_3) s_1 \\
 &= \dot{m}_2 (s_2 - s_1) + \dot{m}_3 (s_3 - s_1)
 \end{aligned}$$

Now,

$$\begin{aligned}
 s_2 - s_1 &= c_p \ln \frac{T_2}{T_1} - R \ln \frac{p_2}{p_1} \\
 &= 1.005 \ln \frac{330}{300} - 0.287 \ln \frac{1}{4} \\
 &= 0.494 \text{ kJ/kgK}
 \end{aligned}$$

$$\begin{aligned}
 s_3 - s_1 &= c_p \ln \frac{T_3}{T_1} - R \ln \frac{p_3}{p_1} \\
 &= 1.005 \ln \frac{270}{300} - 0.287 \ln \frac{1}{4} \\
 &= 0.292 \text{ kJ/kgK}
 \end{aligned}$$

$$\begin{aligned}
 \dot{S}_{\text{gen}} &= 1 \times 0.494 + 1 \times 0.292 \\
 &= 0.786 \text{ kW/K}
 \end{aligned}$$

Since  $\dot{S}_{\text{gen}} > 0$ , the device is possible. Such devices actually exist and are called *vortex tubes*. Although they have low efficiencies, they are suitable for certain applications like rapid cooling of soldered parts, electronic component cooling, cooling of machining operations and so on. The vortex tube is essentially a passive device with no moving parts. It is relatively maintenance free and durable.

**Example** A room is maintained at 27°C while the surroundings are at 2°C. The temperatures of the inner and outer surfaces of the wall ( $k = 0.71 \text{ W/mK}$ ) are measured to be 21°C and 6°C, respectively. Heat flows steadily through the wall 5 m × 7 m in cross-section and 0.32 m in thickness. Determine (a) the rate of heat transfer through the wall, (b) the rate of entropy generation in the wall, and (c) the rate of total entropy generation with this heat transfer process.

**Solution**

$$\begin{aligned}\dot{Q} &= kA \frac{\Delta T}{L} = 0.71 \frac{\text{W}}{\text{mK}} \times (5 \times 7) \text{m}^2 \times \frac{(21-6) \text{K}}{0.32 \text{ m}} \\ &= 1164.84 \text{ W} \quad \text{Ans. (a)}\end{aligned}$$

Taking the wall as the system, the entropy balance in rate form gives:

$$\begin{aligned}\frac{dS_{\text{wall}}}{dt} &= \dot{S}_{\text{transfer}} + \dot{S}_{\text{gen.wall}} \\ 0 &= \sum \frac{\dot{Q}}{T} + \dot{S}_{\text{gen.wall}} \\ 0 &= \frac{1164.84}{294} - \frac{1164.84}{279} + \dot{S}_{\text{gen.wall}}\end{aligned}$$

Rate of entropy generation in the wall

$$\dot{S}_{\text{gen.wall}} = 4.175 - 3.962 = 0.213 \text{ W/K} \quad \text{Ans. (b)}$$

The entropy change of the wall is zero during this process, since the state and hence the entropy of the wall does not change anywhere in the wall.

To determine the rate of total entropy generation during this heat transfer process, we extend the system to include the regions on both sides of the wall,

$$\begin{aligned}\frac{dS_{\text{total}}}{dt} &= \dot{S}_{\text{transfer}} + \dot{S}_{\text{gen.total}} \\ 0 &= \sum \frac{\dot{Q}}{T} + \dot{S}_{\text{gen.total}} \\ 0 &= \frac{1164.84}{300} - \frac{1164.84}{275} + \dot{S}_{\text{gen.total}}\end{aligned}$$

$$\dot{S}_{\text{gen.total}} = 4.236 - 3.883 = 0.353 \text{ W/K} \quad \text{Ans. (c)}$$

UNIT -III

Pure substance

A substance that has a fixed chemical composition throughout the system is called a pure substance. Water, hydrogen, nitrogen, and carbon monoxide, for example, are all pure substance. A pure substance can also be a mixture of various chemical elements or compounds as long as the mixture is homogeneous. Air, a mixture of several compounds, is often considered to be a pure substance because it has a uniform chemical composition. “A mixture of two or more phases of a pure substance is still a pure substance as long as the chemical composition of all phases is the same. A mixture of ice and liquid water, for example, is a pure substance because both phases have the same chemical composition.”

PVT Surface

Pressure can be expressed as a function of temperature and specific volume:  $p = p(T, v)$ . The plot of  $p = p(T, v)$  is a surface called  $p$ - $v$ - $T$  surface. Figure 3.1 shows the  $p$ - $v$ - $T$  surface of a substance such as water that expands on freezing.

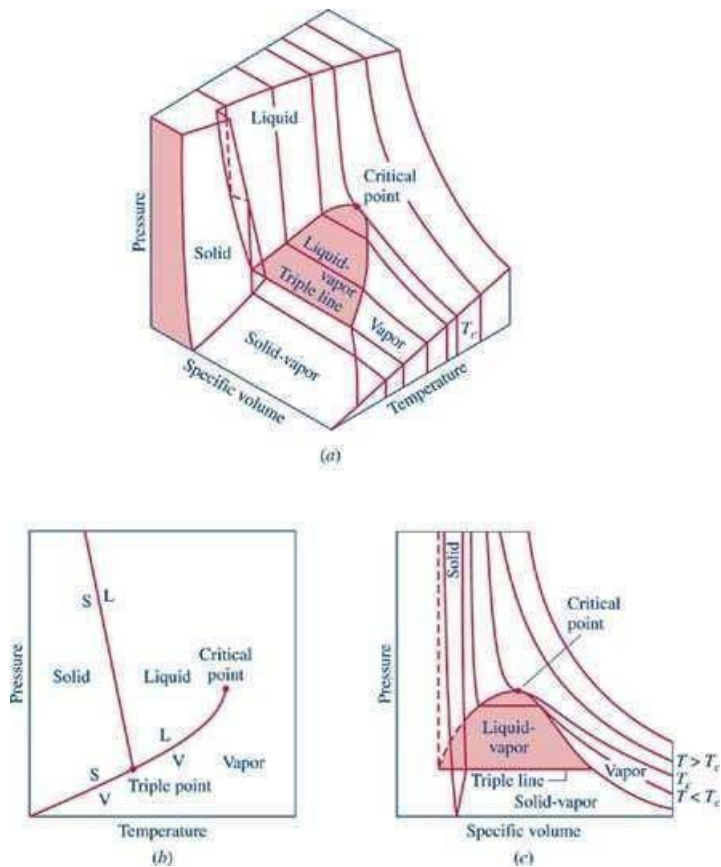
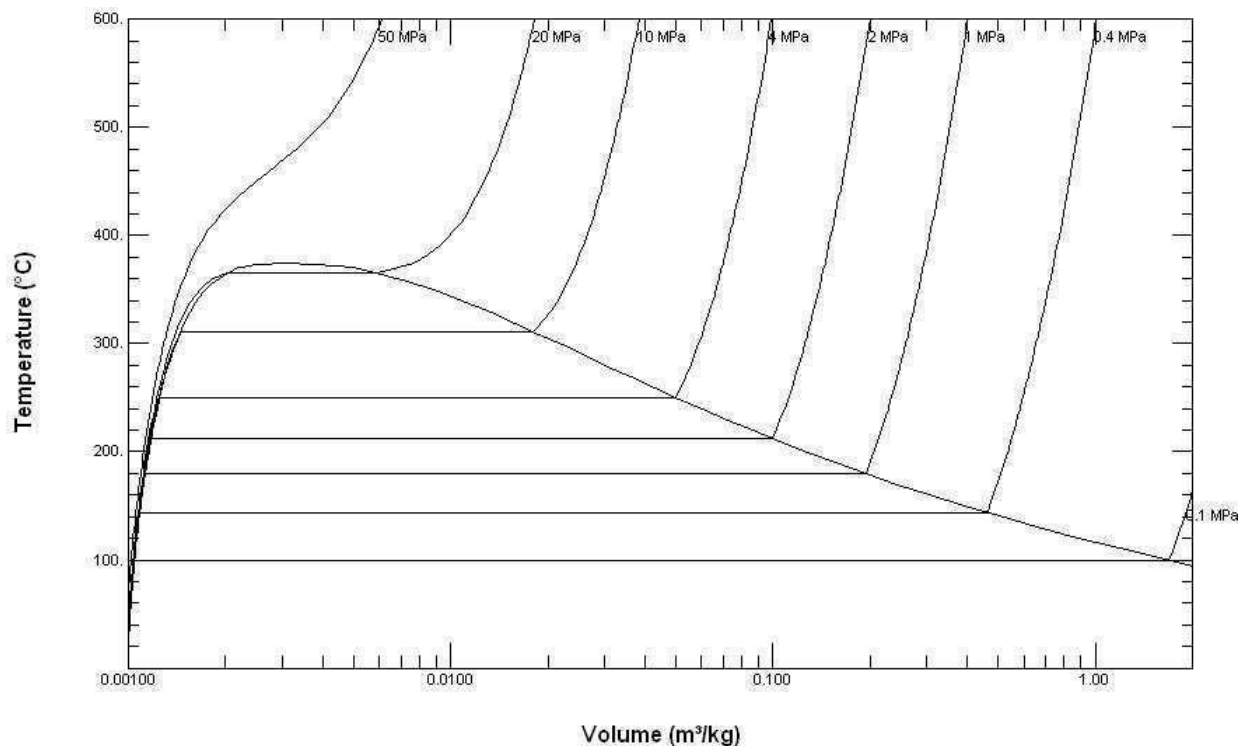

**Figure 3.1**  $p$ - $v$ - $T$  surface and projections for a substance that expands on freezing. (a) 3-D view (b)  $p$ - $T$  diagram (c)  $p$ - $v$  diagram<sup>2</sup>.

The location of a point on the  $p$ - $v$ - $T$  surface gives the values of pressure, specific volume, and temperature at equilibrium. The regions on the  $p$ - $v$ - $T$  surface labeled *solid*, *liquid*, and *vapor* are single-phase regions. The state of a single phase is determined by any two of the properties: pressure, temperature, and specific volume. The two-phase regions where two phases exist in equilibrium separate the single-phase regions. The two-phase regions are: liquid-vapor, solid-liquid, and solid-vapor. Temperature and pressure are dependent within the two-phase regions. Once the temperature is specified, the pressure is determined and vice versa. The states within the two-phase regions can be fixed by specific volume and either temperature or pressure.

The projection of the  $p$ - $v$ - $T$  surface onto the  $p$ - $T$  plane is known as the phase diagram as shown in Figure 3.1 (b). The two-phase regions of the  $p$ - $v$ - $T$  surface reduce to lines in the phase diagram. A point on any of these lines can represent any two-phase mixture at that particular temperature and pressure. The triple line of the  $p$ - $v$ - $T$  surface projects onto a point on the phase diagram called the triple point. Three phases coexist on the triple line or the triple point.

The constant temperature lines of the  $p$ - $v$  diagram are called the isotherms. For any specified temperature less than the critical temperature, the pressure remains constant within the two-phase region even though specific volume changes. In the single-phase liquid and vapor regions the pressure decreases at fixed temperature as specific volume increases. For temperature greater than or equal to the critical temperature, there is no passage across the two-phase liquid-vapor region.



**Figure 3.1-2**  $T$ - $v$  diagram for water (to scale).

Figure 3.1-2 is a  $T$ - $v$  diagram for water. For pressure greater than or equal to the critical pressure, temperature increases continuously at fixed pressure as the specific volume increases and there is no passage across the two-phase liquid-vapor region. The isobaric curve marked 50 MPa in Figure 3.1-2 shows this behavior. For pressure less than the critical value, there is a two-phase region where the temperature remains constant at a fixed pressure as the two-phase region is traversed. The isobaric curve with values of 20 MPa or less in Figure 3.1-2 shows the constant temperature during the phase change.

At 100°C, the saturated volumes of liquid and vapor water are 1.0434 cm<sup>3</sup>/g and 1,673.6 cm<sup>3</sup>/g, respectively. The quality of steam is the mass fraction of water vapor in a mixture of liquid and vapor water. The specific volume of 100°C steam with a quality of 0.65 is given by

$$v = (1 - 0.65)v^L + 0.65 v^V = (0.35)(1.0434) + (0.65)(1,673.6) = 1088.2 \text{ cm}^3/\text{g}$$

### Phase Behavior

We will consider a phase change of 1 kg of liquid water contained within a piston-cylinder assembly as shown in Figure 3.2-1a. The water is at 20°C and 1.014 bar (or 1 atm) as indicated by point (1) on Figure 3.2-2.

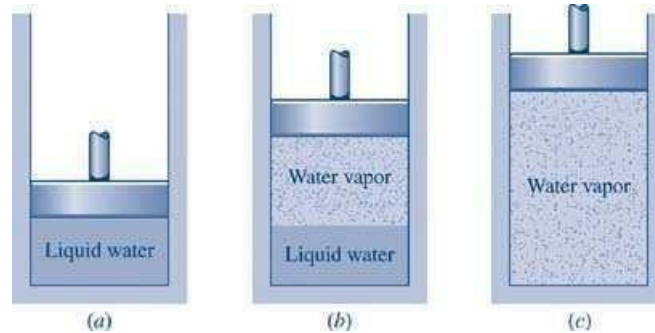

**Figure 3.2-1** Phase change at constant pressure for water<sup>3</sup>

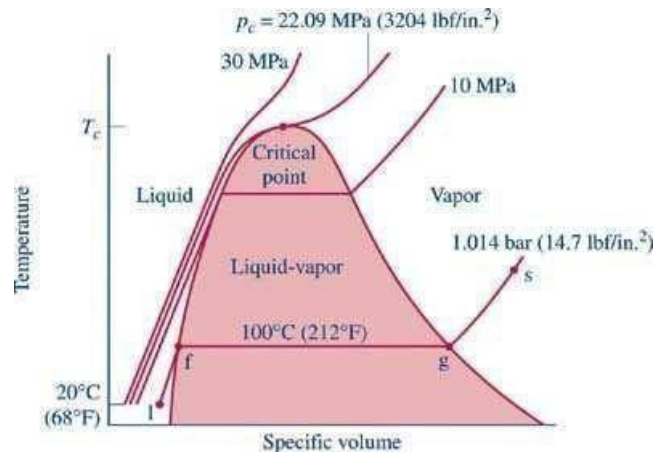

**Figure 3.2-2** Sketch of  $T$ - $v$  diagram for water

As the water is heated at constant pressure, the temperature increases with a slight increase in specific volume until the system reaches point (f). This is the saturated liquid state corresponding to 1.014 bar. The saturation temperature for water at 1.014 bar is 100°C. The liquid states along the line segment 1-f are called *subcooled* or *compressed* liquid states. When the system is at the saturated liquid state (point f in Figure 3.2-2) any additional heat will cause the liquid to evaporate at constant pressure as shown in Figure 3.2-1b. When a mixture of liquid and vapor exists in equilibrium, the liquid phase is a saturated liquid and the vapor phase is a saturated vapor. Liquid water continues to evaporate with additional heat until it becomes all saturated vapor at point (g). Any further heating will cause an increase in both temperature and specific volume and the saturated vapor becomes superheated vapor denoted by point (s) in Figure 3.2-2. For a two-phase liquid-vapor mixture, the quality  $x$  is defined as the mass fraction of vapor in the mixture

$$x = \frac{m_{\text{vapor}}}{m_{\text{vapor}} + m_{\text{liquid}}}$$

When a substance exists as part liquid and part vapor at saturation conditions, its quality ( $x$ ) is defined as the ratio of the mass of the vapor to the total mass of both vapor and liquid.

#### Enthalpy–Entropy Chart

An enthalpy–entropy chart, also known as the H–S chart or Mollier diagram, plots the total heat against entropy, describing the enthalpy of a thermodynamic system. A typical chart covers a pressure range of 0.01–1000 bar, and temperatures up to 800 degrees Celsius. It shows enthalpy  $H$  in terms of internal energy  $U$ , pressure  $p$  and volume  $V$  using the relationship  $H=U+pV$  or, in terms of specific enthalpy, specific entropy and specific volume.

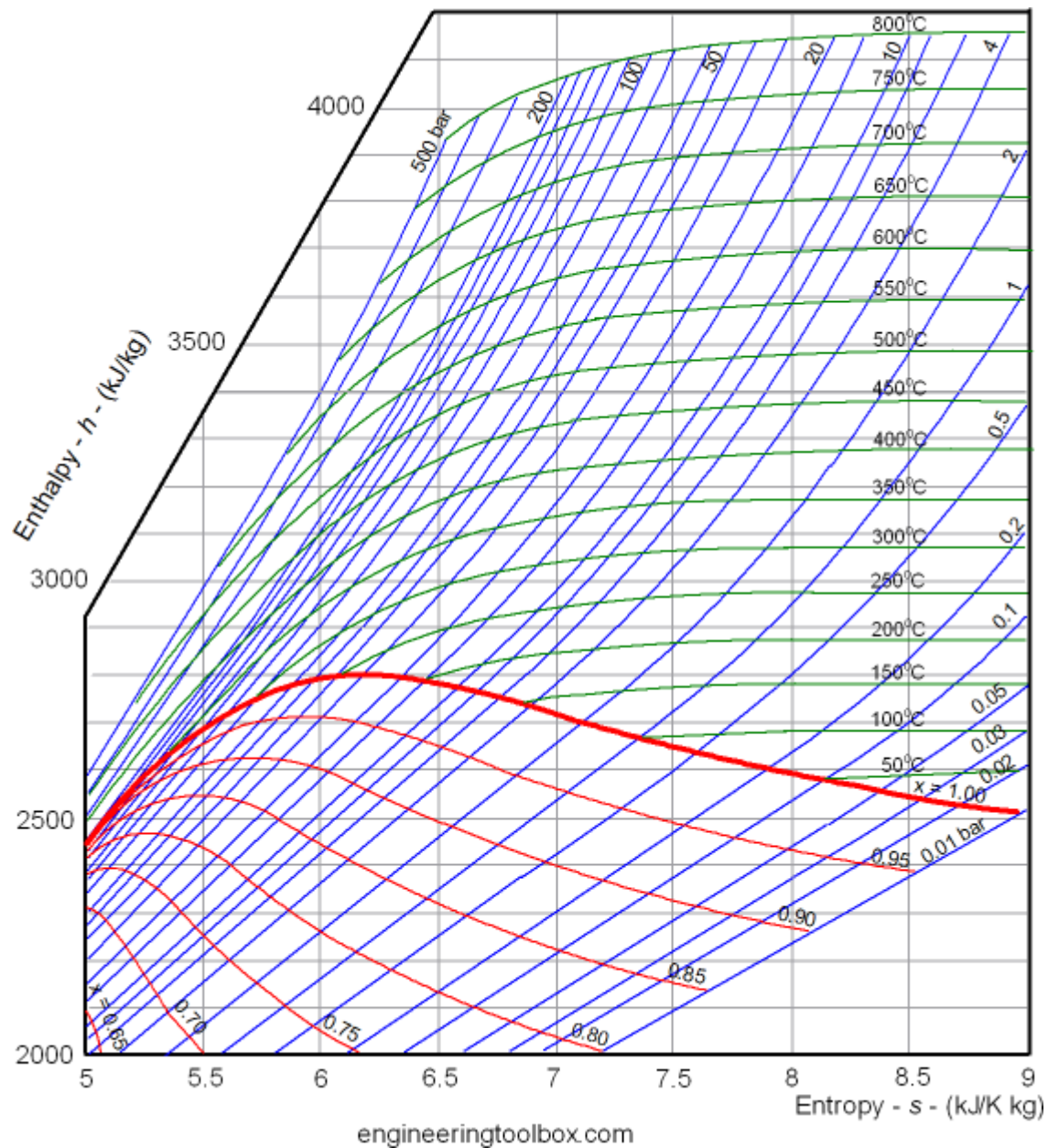

On the diagram, lines of constant pressure, constant temperature and volume are plotted, so in a two-phase region, the lines of constant pressure and temperature coincide. Thus, coordinates on the diagram represent entropy and heat.

A vertical line in the  $h$ – $s$  chart represents an isentropic process. The process 3–4 in a Rankine cycle is isentropic when the steam turbine is said to be an ideal one. So the expansion process in a turbine can be easily calculated using the  $h$ – $s$  chart when the process

is considered to be ideal (which is the case normally when calculating enthalpies, entropies, etc. Later the deviations from the ideal values and they can be calculated considering the isentropic efficiency of the steam turbine used.

Lines of constant dryness fraction ( $x$ ), sometimes called the quality, are drawn in the wet region and lines of constant temperature are drawn in the superheated region.  $x$  gives the fraction (by mass) of gaseous substance in the wet region, the remainder being colloidal liquid droplets. Above the heavy line, the temperature is above the boiling point, and the dry (superheated) substance is gas only.

Characteristics of the critical point:

- For saturated phase often its enthalpy is an important property.
- Enthalpy-pressure charts are used for refrigeration cycle analysis.
- Enthalpy-entropy charts for water are used for steam cycle analysis.
- Note: Unlike pressure, volume and temperature which have specified numbers associated with it, in the case of internal energy, enthalpy (and entropy) only changes are required. Consequently, a base (or datum) is defined -as you have seen in the case of water.

Let  $V$  be total volume of liquid vapour mixture of quality  $x$ ,  $V_f$  the volume of saturated liquid and  $V_g$  the volume of saturated vapour, the corresponding masses being  $m$ ,  $m_f$  and  $m_g$  respectively.

$$\text{Now, } m = m_f + m_g$$

$$V = V_f + V_g$$

$$m v = m_f v_f + m_g v_g$$

Saturation States

When a liquid and its vapour are in equilibrium at certain pressure and temperature, only the pressure or the temperature is sufficient to identify the saturation state.

If pressure is given, the temperature of the mixture gets fixed, which is known as saturation temperature, or if the temperature is given, the saturation pressure gets fixed.

Saturation liquid or saturated vapour has only one independent variable, i.e. only one property is required to be known to fix up the state.

Type of Steam

Wet steam:

Wet steam is defined as steam which is partly vapour and partly liquid suspended in it. It means that evaporation of water is not complete.

Dry saturated steam:

When the wet steam is further heated, and it does not contain any suspended particles of water, it is known as dry saturated steam.

Superheated steam: When the dry steam is further heated at constant pressure, thus raising its temperature, it is called superheated steam.

Measurement of Steam Quality:

The state of a pure substance gets fixed if two independent properties are given. A pure substance is thus said to have two degrees of freedom. Of all thermodynamic properties, it is easiest to measure the pressure and temperature of a substance. Therefore, whenever pressure and temperature are independent properties, it is the practice to measure them to determine that state of the substance.

Types of Calorimeters used for measurement of Steam Quality

- Barrel Calorimeter
- Separating Calorimeter
- Throttling Calorimeter
- Combined Separating and Throttling calorimeter

Barrel Calorimeter

Dryness fraction of steam can be found out very conveniently by barrel calorimeter as shown in figure. A vessel contains a measured quantity of water. Also water equivalent of the vessel is determined experimentally and stamped platform of weighing machine.

Sample of steam is passed through the sampling tube into fine exit holes for discharge of steam in the cold water.

The steam gets condensed and the temperature of water rises. The weighing machine gives the steam condensed.

From the law of conservation of energy,

*HeatLost =*

*HeatGain*

$$x = \frac{C_p \{ M/m(t_2 - t_1) - (t_s - t_2) \}}{h_{fg}}$$

Where, x = quantity of steam in the main pipe

h<sub>fg</sub> = latent heat of vaporization at pressure p

$C_p$  = specific heat of water at constant pressure p m  
 $m$  = mass of steam condensed  
 $M$  = Equivalent mass of water at commencement  
 $t_s$  = Sat. temperature;  
 $t_1$  = temperature of Water at commencement  
 $t_2$  = final temperature after steam has condensed

### Separating Calorimeter

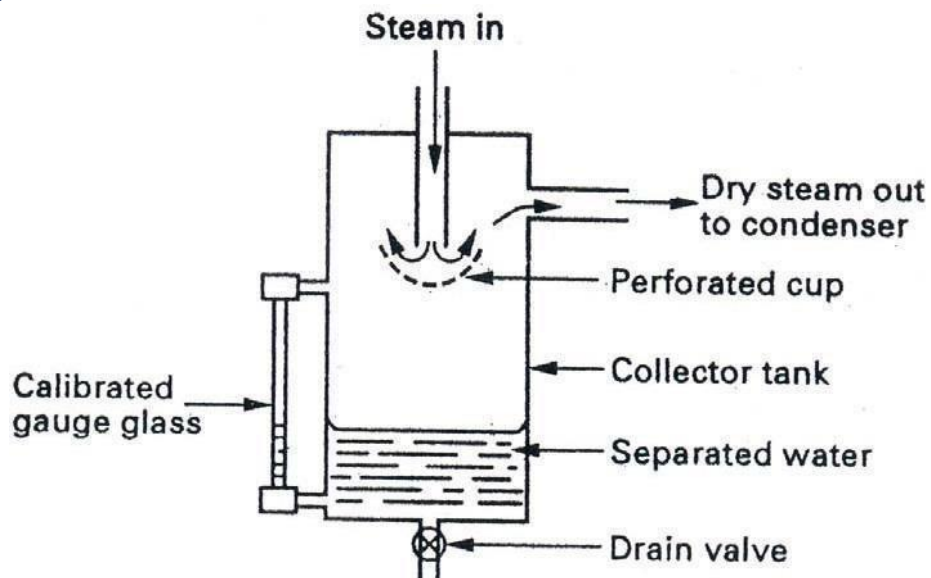

The wet steam enters at the top from the main steam pipe through holes in the sampling pipe facing up stream which should be as far as possible downstream from elbows and valves to ensure representative sample of steam when in operation the wet steam entering passes down the central passage and undergoes a sudden reversal of direction of motion when strikes perforated cup.

#### Advantages:

Quick determination of dryness fraction of very wet steam

#### Disadvantages:

It leads to inaccuracy due to incomplete separation of water

Dryness fraction calculated is always greater than actual dryness fraction.

Throttling Calorimeter

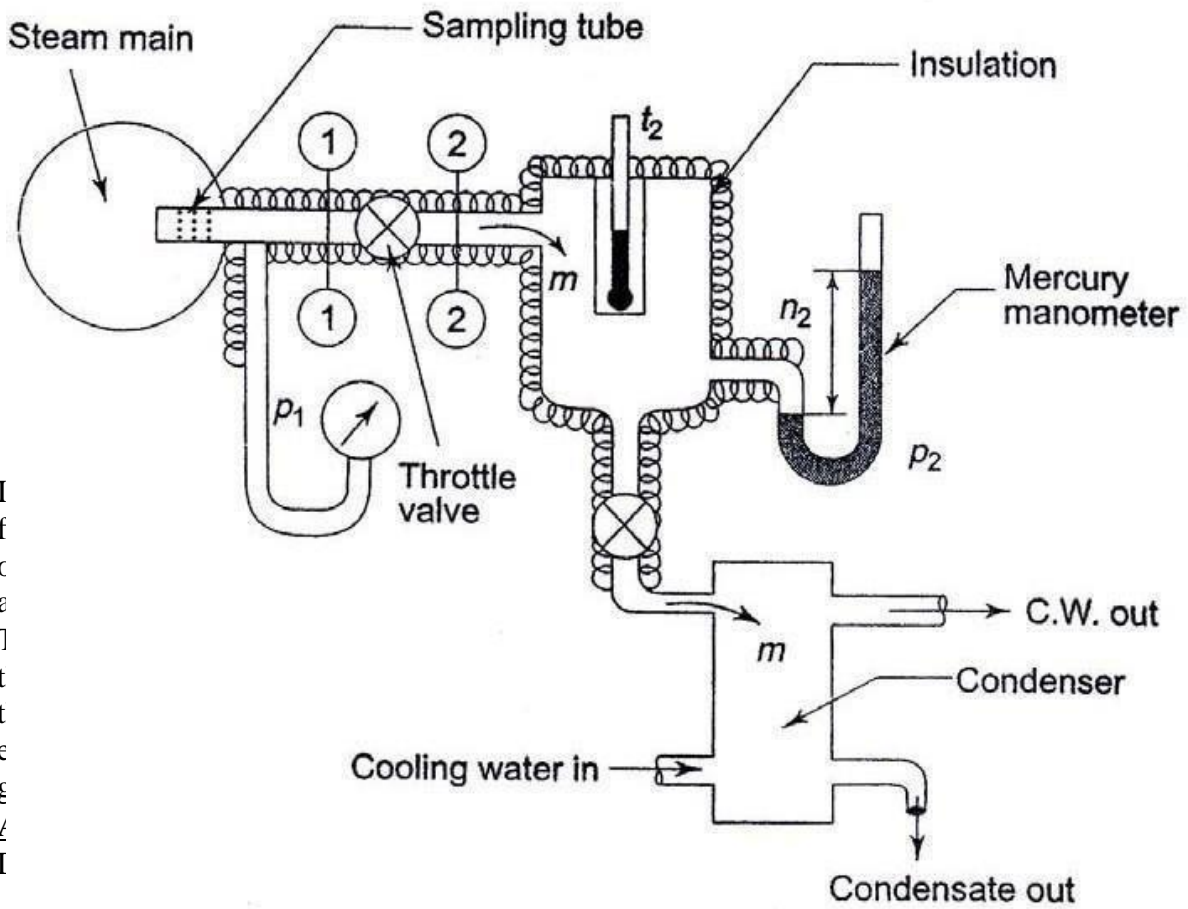

I  
f  
c  
a  
l  
c  
u  
l  
a  
t  
e  
d  
I

3  
3  
-3

Disadvantages:

It is not possible to find dryness fraction of very wet steam.

Combined Separating and Throttling calorimeter

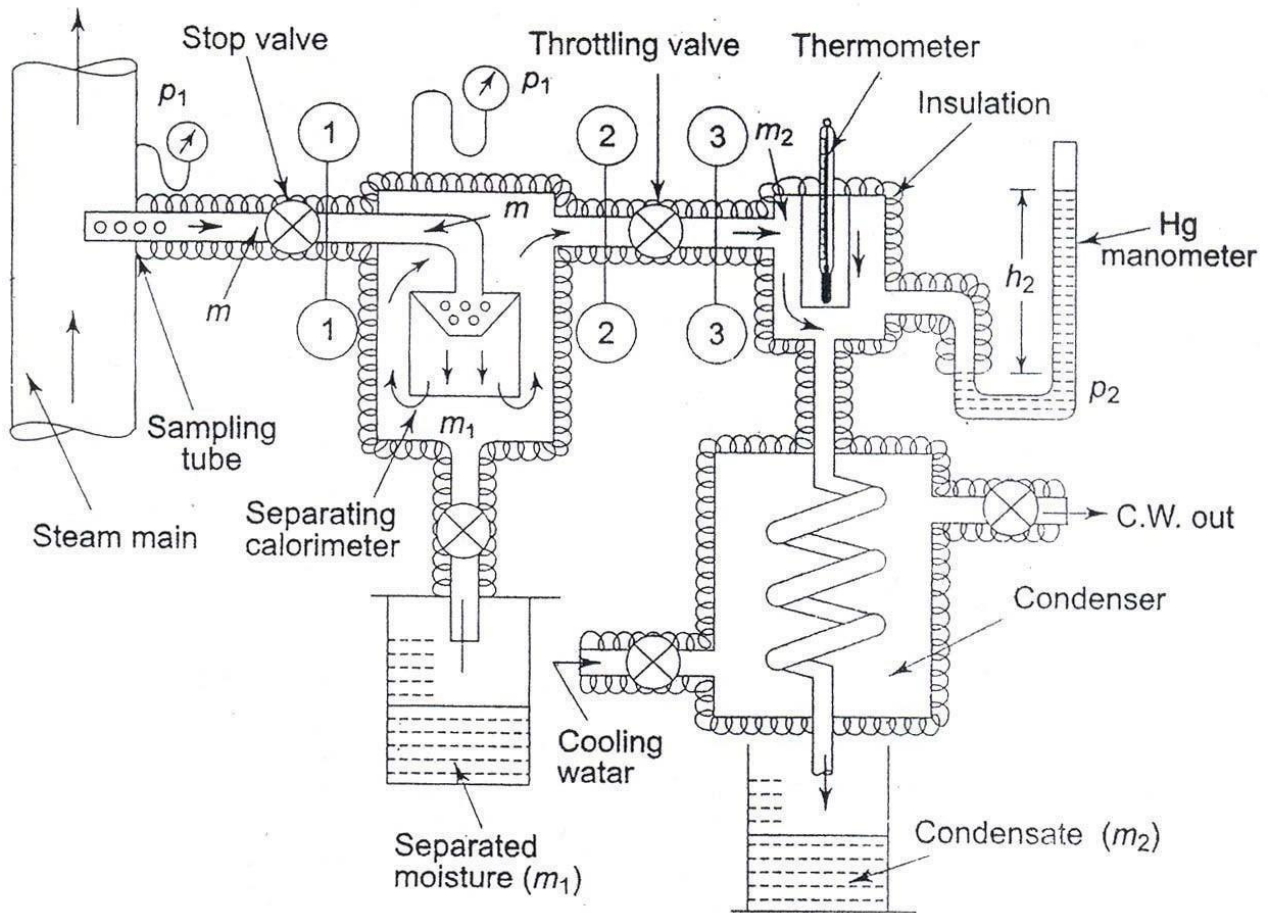

When the steam is very wet and the pressure after throttling is not low enough to take the steam to the superheated region, then a combined separating and throttling calorimeter is used for the measurement of quality.

Steam from the main is first passed through a separator where some part of the moisture separates out due to the sudden change in direction and falls by gravity, and the partially dry vapour is then throttled and taken to the superheated region.

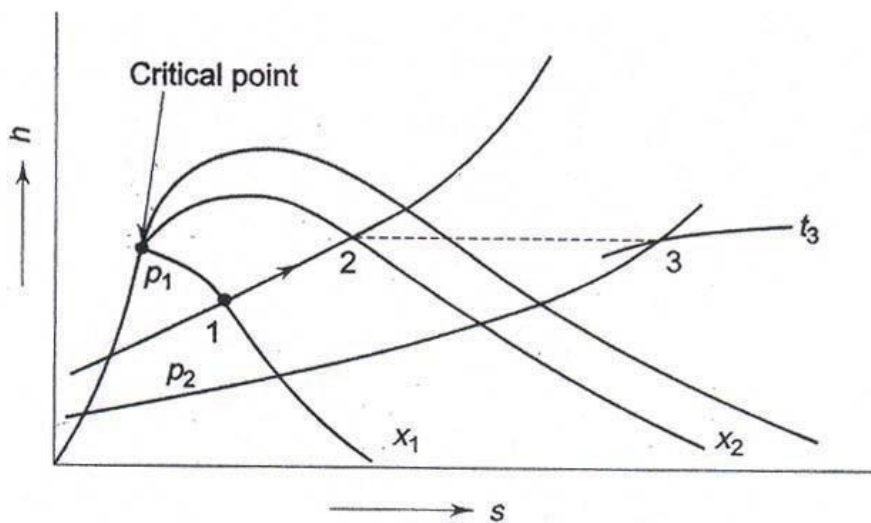

*Separating and throttling processes on  $h-s$  plot*

In Fig. process 1-2 represents the moisture separation from the wet sample of steam at constant pressure  $P_1$  and process 2-3 represents throttling to pressure  $P_2$ . With  $P_2$  and  $t_3$  being measured,  $h_3$  can be found out from the superheated steam table.

$$h_3 = h_2 = h_{f,p_1} + x_2 h_{fg,p_1}$$

Therefore  $x_2$ , the quality of steam after partial moisture separation can be evaluated. If  $m$  kg of steam, is taken through the sampling tube in  $t$  s,  $m_1$  kg of it is separated, and  $m_2$  kg is throttled and then condensed to water and collected, then  $m = m_1 + m_2$  and at state 2, the mass of dry vapour will be  $x_2 m_2$ . Therefore, the quality of the sample of steam at state 1,  $x_1$  is given by . .

$$x_1 = \frac{\text{mass of dry vapour state 1}}{\text{mass of liquid – vapour mixture at state 1}}$$

$$x_1 = \frac{m_2}{m_1 + m_2}$$

$$x = \frac{m_g}{m_g + m_f} = \frac{50}{50 + 1.5} = 0.971 \text{ ----- Ans}$$

Eg. Steam is generated at 8 bar from water at 32°C. Determine the heat required to produce 1 kg of steam (a) when the dryness fraction is 0.85 (b) when steam is dry saturated and (c) when the steam is superheated to 305°C. The specific heat of superheated steam may be taken as 2.093 kJ/kg-K.

Given:

Steam pressure (p) = 8 bar Initial temperature of water ( $T_1$ ) = 32°C Mass of steam (m) = 1 kg

Required: Heat required when (a)  $x = 0.85$  (b)

$x = 1$  (c)  $T_{sup} = 305^\circ\text{C}$

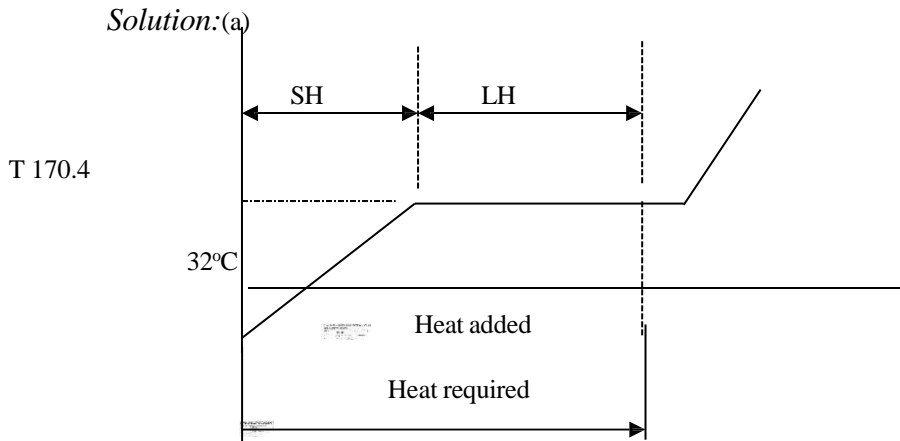

Heat required = Sensible heat addition + Latent heat

addition Sensible heat addition =  $m C_{pw} (t_s - T_1)$

$t_s$  = saturation temperature = 170.4°C at 8 bar from steam

table  $C_{pw}$  = Specific heat at constant pressure = 4.186 kJ/kg

(Taken)

$$\text{Sensible Heat addition} = 1 \times 4.186 \times (170.4 - 32)$$

$$= 79.34 \text{ kJ/kg}$$

Latent heat addition / kg =  $x h_{fg}$

Latent heat ( $h_{fg}$ ) = 2046.5 kJ/kg from steam table at 8 bar

Latent heat addition for 'm' kg =  $m \times h_{fg}$

$$= 1 \times 0.85 \times (2046.5)$$

$$= 1739.525 \text{ kJ/kg}$$

Total heat required = 579.34 + 1739.525

$$= 2318.865 \text{ kJ/kg --- Ans}$$

(b)

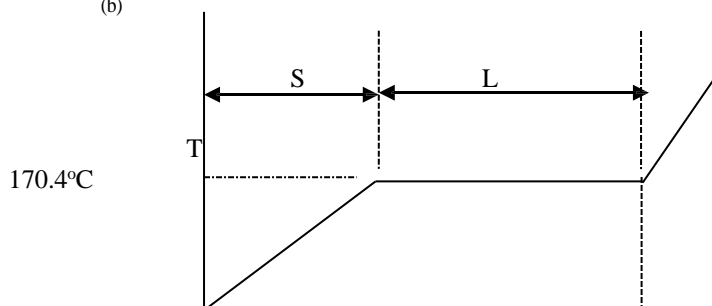

Heat required = Sensible heat addition + Latent heat addition Latent heat addition / kg =  $x h_{fg}$

Latent heat ( $h_{fg}$ ) = 2046.5 kJ/kg from steam table at 8

bar Latent heat addition for 'm' kg =  $m \times h_{fg}$

$$= 1 \times 1 \times (2046.5)$$

$$= 2046.5 \text{ kJ/kg}$$

Total heat required = 579.34 + 2046.5

$$= 2625.84 \text{ kJ/kg --- Ans}$$

Heat required = Sensible heat addition + Latent heat addition + Sensible Heat addition

Sensible heat addition to superheated steam

$$\begin{aligned} &= m C_{pv} (T_{\text{sup}} - t_s) \\ &= 1 \times 2.093 \times (305 - 170.4) \\ &= 281.72 \text{ kJ/kg} \end{aligned}$$

Latent heat addition / kg =  $h_{fg}$

$$\text{Latent heat } (h_{fg}) = 2046.5 \text{ kJ/kg from steam table at 8 bar}$$

$$\text{Total heat required} = 579.34 + 2046.5 + 281.72$$

$$= 2907.56 \text{ kJ/kg --- Ans}$$

### **Ideal Gas:**

Perfect gas, also called ideal gas, a gas that conforms, in physical behaviour, to a particular, idealized relation between pressure, volume, and temperature called the general gas law.

Gas Laws:

#### Boyle's Law

Boyle's Law Pressure is inversely proportional to volume:  $p \propto 1/v$  Robert Boyle noticed that when the volume of a container holding an amount of gas is increased, pressure decreases, and vice versa (while the temperature is held constant). Note that this is not a linear relationship between  $p$  and  $V$ .

#### Charles' Law:

Charles' Law Volume is directly proportional to temperature:  $V = cT$ , where  $c > 0$  is constant. Scientist Jacques Charles noticed that if air in a balloon is heated, the balloon expands. For an ideal gas, this relationship between  $V$  and  $T$  should be linear (as long as pressure is constant).

#### Charles' and Boyle's Laws combined

Combine the two laws above:  $pV/T = K$ , where  $k$  is a constant,  $= pV = mRT$

#### The Individual Gas Constant - R

The Individual Gas Constant depends on the particular gas and is related to the molecular weight of the gas. The value is independent of temperature. The individual gas constant,  $R$ , for a gas can be calculated from the universal gas constant,  $R_u$  (given in several units below), and the gas molecular weight,  $M_{\text{gas}}$ :

$$R = R_u / M_{\text{gas}}$$

In the SI system units are J/kg K.

#### The Universal Gas Constant - $R_u$

The Universal Gas Constant -  $R_u$  - appears in the ideal gas law and can be expressed as the product between the Individual Gas Constant -  $R$  - for the particular gas - and the Molecular Weight -  $M_{\text{gas}}$  - for the gas, and is the same for all ideal or perfect gases:

$$R_u = M_{\text{gas}} R, \text{ kJ/(kmol.K)} : 8.3144598$$

#### The Molecular weight of a Gas Mixture

The average molecular weight of a gas mixture is equal to the sum of the mole fractions of each gas multiplied by the molecular weight of that particular gas:

$$M_{\text{mixture}} = \sum x_i \cdot M_i = (x_1 \cdot M_1 + \dots + x_n \cdot M_n)$$

where

$x_i$  = mole fractions of each gas

$M_i$  = the molar mass of each gas

**Throttling Process:**

The porous plug experiment was designed to measure temperature changes when a fluid flows steadily through a porous plug which is inserted in a thermally insulated, horizontal pipe. The apparatus used by Joule and Thomson is shown in Figure

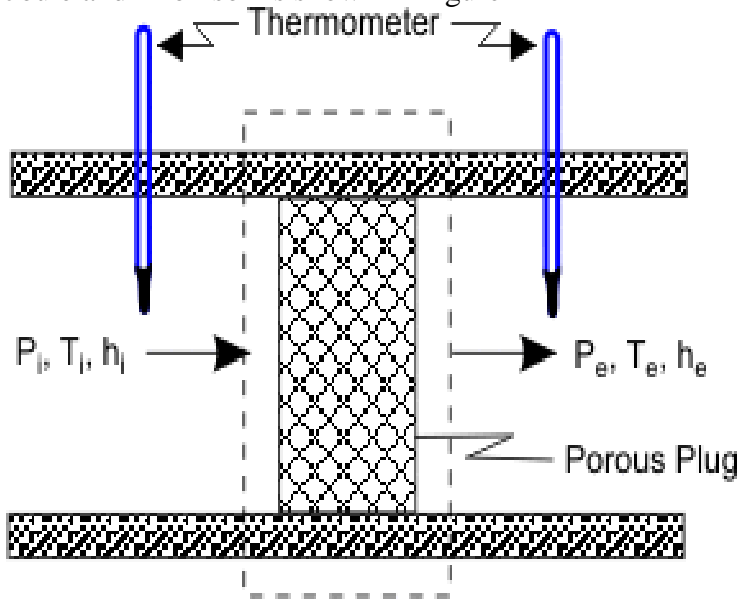

A gas at pressure and temperature flows continuously through a porous plug in a tube and emerges into a space which is maintained at a constant pressure. The device is thermally insulated and kept horizontal. Consider the dotted portion as control volume.

$$\dot{Q} = 0, W_{sh} = 0. \text{ This results in } h_i = h_e$$

Therefore, whenever a fluid expands from a region of high pressure to a region of low pressure through a porous plug, partially opened valve or some obstruction, without exchanging any energy as heat and work with the surrounding (neglecting, the changes in PE and KE), the enthalpy of the fluid remains constant, and the fluid is said to have undergone a throttling process.

Free expansion (or unresisted expansion) process. A free expansion occurs when a fluid is allowed to expand suddenly into a vacuum chamber through an orifice of large dimensions. In this process, no heat is supplied or rejected and no external work is done. Hence the total heat of the fluid remains constant. This type of expansion may also be called as constant total heat expansion. It is thus obvious, that in a free expansion process,

$$Q_{1-2} = 0, W_{1-2} = 0 \text{ and } dU = 0.$$

van der Waals Equation of State:

The ideal gas law treats the molecules of a gas as point particles with perfectly elastic collisions. This works well for dilute gases in many experimental circumstances. But gas molecules are not point masses, and there are circumstances where the properties of the molecules have an experimentally measurable effect. A modification of the ideal gas law

was proposed by Johannes D. van der Waals in 1873 to take into account molecular size and molecular interaction forces. It is usually referred to as the van der Waals equation of state.

$$\left[ P + a \left( \frac{n}{V} \right)^2 \right] \left( \frac{V}{n} - b \right) = RT$$

The constants  $a$  and  $b$  have positive values and are characteristic of the individual gas. The van der Waals equation of state approaches the ideal gas law  $PV=nRT$  as the values of these constants approach zero. The constant  $a$  provides a correction for the intermolecular forces. Constant  $b$  is a correction for finite molecular size and its value is the volume of one mole of the atoms or molecules.

Since the constant  $b$  is an indication of molecular volume, it could be used to estimate the radius of an atom or molecule, modeled as a sphere. Fishbane et al. give the value of  $b$  for nitrogen gas as  $39.4 \times 10^{-6} \text{ m}^3/\text{mol}$ .

## UNIT-IV

**Mixtures of perfect Gases:**

A mixture, consisting of several pure substances, is referred to as a solution. Examples of pure substances are water, ethyl alcohol, nitrogen, ammonia, sodium chloride, and iron. Examples of mixtures are air, consisting of nitrogen, oxygen and a number of other gases, aqueous ammonia solutions, aqueous solutions of ethyl alcohol, various metal alloys. The pure substances making up a mixture are called components or constituents.

## Mixture of ideal gases

Basic assumption is that the gases in the mixture do not interact with each other.

Consider a mixture with components  $l = 1, 2, 3, \dots$  with masses  $m_1, m_2, m_3 \dots m_i$  and with  $N_1, N_2, N_3, \dots, N_i, \dots$  number of moles.

The total mixture occupies a volume  $V$ , has a total pressure  $P$  and temperature  $T$  (which is also the temperature of each of the component species)

The total mass

$$m = \sum m_i \quad (4.1)$$

Total number of mole  $N$

$$N = \sum N_i \quad (4.2)$$

Mass fraction of species  $i$

$$\phi_i = \frac{m_i}{m} \quad (4.3)$$

Mole fraction of species  $i$

$$Y_i = \frac{N_i}{N} \quad (4.4)$$

The mass and number of moles of species  $i$  are related by

$$m_i = N_i M_i \quad (4.5)$$

$N_i$  is the number of moles of species  $i$  and  $M_i$  is the molar mass of species  $i$

Also to be noted

$$\sum \phi_i = 1 \quad \text{and} \quad \sum Y_i = 1 \quad (4.6)$$

$$(4.7)$$

We can also define a molar mass of the mixture as

$$M = \frac{m}{N} = \frac{\sum N_i M_i}{N} \quad (4.7)$$

or,

$$M = \frac{\sum N_i}{N} M_i$$

or,

$$M = \sum Y_i M_i$$

Dalton 's Law of partial pressure

Total pressure of an ideal gas mixture is equal to the sum of the partial pressures of the constituent components, That is

$$P = \sum P_i \quad (4.9)$$

P is the total pressure of the mixture

$P_i$  is the partial pressure of species  $i$

= pressure of the species if it existed alone in the given temperature T and volume V

$$P_i = \frac{N_i \hat{R} T}{V} \quad (4.10)$$

$\hat{R}$  is the universal gas constant = 8.314 kJ/k mol K

Amagat's Law:

Volume of an ideal gas mixture is equal to the sum of the partial volumes

$$V = \sum V_i \quad (4.11)$$

V = total volume of the mixture

$V_i$  = partial volume of the species  $i$

= volume of the species if it existed alone in the given temperature T and pressure

For an ideal gas

$$V_i = \frac{N_i \hat{R} T}{P} \quad (4.12)$$

Amagat's Law

$$V = \sum V_i = \frac{\sum N_i \hat{R}T}{P} = \frac{\hat{R}T}{P} \sum N_i = \frac{\hat{R}T}{P} N$$

Or

$$V = \frac{N \hat{R}T}{P} \tag{4.13}$$

The volume fraction of species *I*

$$\frac{V_i}{V} = \frac{N_i \hat{R}T}{P} \frac{P}{N \hat{R}T} = \frac{N_i}{N} = Y_i$$

or,

$$\frac{V_i}{V} = Y_i \tag{34.16}$$

Volume fraction = Mole fraction

Mass based analysis is known as gravimetric analysis

Mole based analysis is known as molar analysis

**Mole Fraction:**

The composition of a gas mixture can be described by the mole fractions of the gases present. The mole fraction (*X*) of any component of a mixture is the ratio of the number of moles of that component to the total number of moles of all the species present in the mixture (*n<sub>tot</sub>*):

$$x_A = \text{moles of A} / \text{total moles}$$

$$= n_A / n_{tot}$$

$$= n_A / (n_A + n_B + \dots)$$

The mole fraction is a dimensionless quantity between 0 and 1.

If *x<sub>A</sub>* = 1.0, then the sample is pure A, not a mixture.

If *x<sub>A</sub>* = 0, then no A is present in the mixture.

The sum of the mole fractions of all the components present must equal 1.

To see how mole fractions can help us understand the properties of gas mixtures, let's evaluate the ratio of the pressure of a gas A to the total pressure of a gas mixture that contains A. We can use the ideal gas law to describe the pressures of both gas A and the mixture: *P<sub>A</sub>* = *n<sub>A</sub>**R**T*/*V* and *P<sub>tot</sub>* = *n<sub>tot</sub>**R**T*/*V*. The ratio of the two is thus

$$P_A / P_{tot} =$$

$$n_A / n_{tot} = x_A$$

$$P_A = x_A P_{tot}$$

**Mass Fraction:**

the mass fraction of a substance within a mixture is the ratio of the mass of that substance to the total mass of the mixture.

Expressed as a formula, the mass fraction is

According to the conservation of mass, we have:

To change from a mass fraction analysis to a mole fraction analysis, we can show that

$$y_i = \frac{mf_i / M_i}{\sum_{i=1}^k mf_i / M_i}$$

**Problem 12-30**

**P-v-T BEHAVIOR OF GAS MIXTURES**

A rigid tank contains 8 kmol of O<sub>2</sub> and 10 kmol of CO<sub>2</sub> gases at 290 K and 150 kPa. Estimate the volume of the tank.



$$V_m = \sum_{i=1}^k V_i(T_m, P_m)$$

$$V_m = \frac{N_m R_u T_m}{P_m} = \frac{(18 \text{ kmol})(8.314 \text{ kPa} \cdot \text{m}^3/\text{kmol} \cdot \text{K})(290 \text{ K})}{150 \text{ kPa}} = 289.3 \text{ m}^3$$

Answer: 289 m<sup>3</sup>

**Problem 12-32**

**P-v-T BEHAVIOR OF GAS MIXTURES**

A rigid tank contains 0.5 kmol of Ar and 2 kmol of N<sub>2</sub> at 250 kPa and 280 K. The mixture is now heated to 400 K. Determine the volume of the tank and the final pressure of the mixture.

$$V_m = \frac{N_m R_u T_m}{P_m} = \frac{(2.5 \text{ kmol})(8.314 \text{ kPa} \cdot \text{m}^3/\text{kmol} \cdot \text{K})(280 \text{ K})}{250 \text{ kPa}} = 23.3 \text{ m}^3$$

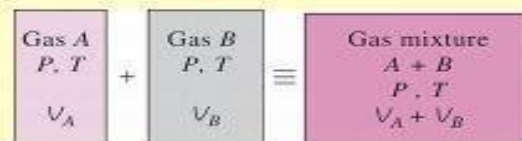

$$V_m = \sum_{i=1}^k V_i(T_m, P_m)$$

$$\frac{P_2 V_2}{T_2} = \frac{P_1 V_1}{T_1} \rightarrow P_2 = \frac{T_2}{T_1} P_1 = \frac{400 \text{ K}}{280 \text{ K}} (250 \text{ kPa}) = 357.1 \text{ kPa}$$

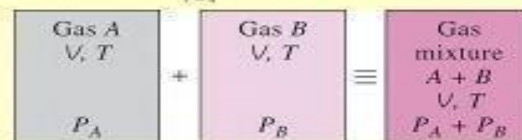

$$P_m = \sum_{i=1}^k P_i(T_m, V_m)$$

**Example**     *0.3 m<sup>3</sup> of helium at 20 bar and 30°C is mixed with 0.7 m<sup>3</sup> of oxygen at 5 bar and 5°C by opening the valve between two tanks. Calculate the heat transfer, if the final temperature of the mixture is 25°C.*

**Solution.**

Given: Volume of helium,  $v_{He} = 0.3 \text{ m}^3$

Pressure of helium,  $p_{He} = 20 \text{ bar} = 20 \times 10^2 \text{ kN/m}^2$

Temperature of helium,  $T_{He} = 30^\circ\text{C} = 30 + 273 = 303 \text{ K}$

Volume of oxygen,  $v_{O_2} = 0.7 \text{ m}^3$

Pressure of oxygen,  $p_{O_2} = 5 \text{ bar} = 5 \times 10^2 \text{ kN/m}^2$

Temperature of oxygen,  $T_{O_2} = 5^\circ\text{C} = 5 + 273 = 278 \text{ K}$

Temperature of the mixture,  
 $T_{mix} = 25^\circ\text{C} = 25 + 273 = 298 \text{ K}$

First of all, let us find the mass and specific heat at constant volume for helium (He) and oxygen (O<sub>2</sub>).

We know that gas constant for helium,

$$R_{He} = \frac{R_u}{\text{Molecular mass of helium } (M_{He})} = \frac{8.314}{4}$$

$$= 2.0785 \text{ kJ/kg K}$$

and gas constant for oxygen,  $R_{O_2} = \frac{R_u}{M_{O_2}} = \frac{8.314}{32} = 0.26 \text{ kJ/kg K}$

From the characteristic equation of gas,  $p v = m R T$ , we have

Mass of helium, 
$$m_{He} = \frac{p_{He} \cdot v_{He}}{R_{He} T_{He}} = \frac{20 \times 10^2 \times 0.3}{2.0785 \times 303} = 0.9527 \text{ kg}$$

and mass of oxygen, 
$$m_{O_2} = \frac{p_{O_2} v_{O_2}}{R_{O_2} T_{O_2}} = \frac{5 \times 10^4 \times 0.7}{0.26 \times 278} = 4.842$$

∴ Total mass of the mixture,

$$m = m_{He} + m_{O_2} = 0.9527 + 4.842 = 5.7947 \text{ kg}$$

Specific heat at constant volume for helium,

$$(c_v)_{He} = \frac{R_{He}}{\gamma_{He} - 1} = \frac{2.0785}{1.66 - 1} = 3.15 \text{ kJ/kg} \quad \dots(\because \gamma_{He} = 1.66)$$

Specific heat at constant volume for oxygen,

$$(c_v)_{O_2} = \frac{R_{O_2}}{\gamma_{O_2} - 1} = \frac{0.26}{1.4 - 1} = 0.65 \text{ kJ/kg K} \quad \dots(\because \gamma_{O_2} = 1.4)$$

and specific heat at constant volume for the gas mixture,

$$(c_v)_{mix} = \frac{m_{He} (c_v)_{He} + m_{O_2} (c_v)_{O_2}}{m} = \frac{0.9527 \times 3.15 + 4.842 \times 0.65}{5.7947}$$

We know that initial internal energy before mixing,

$$\begin{aligned} U_1 &= m_{He} (c_v)_{He} T_{He} + m_{O_2} (c_v)_{O_2} T_{O_2} \\ &= 0.9527 \times 3.15 \times 303 + 4.842 \times 0.65 \times 278 \\ &= 909.3 + 874.95 = 1784.25 \text{ kJ} \end{aligned}$$

and final internal energy after mixing,

$$\begin{aligned} U_2 &= m (c_v)_{mix} \cdot T_{mix} \\ &= 5.7947 \times 1.061 \times 298 = 1832.15 \text{ kJ} \end{aligned}$$

∴ Heat transfer,

$$Q = U_2 - U_1 = 1832.15 - 1784.25 = 47.9 \text{ kJ Ans.}$$

**Example** . Find the increase in entropy when 2 kg of oxygen at 60°C are mixed with 6 kg of nitrogen at the same temperature. The initial pressure of each constituent is 103 kPa and is same as that of the mixture.

**Solution.**

Given: Mass of oxygen,  $m_{O_2} = 2 \text{ kg}$   
 Temperature of oxygen,  $T_{O_2} = 60^\circ\text{C} = 60 + 273 = 333 \text{ K}$   
 Mass of nitrogen,  $m_{N_2} = 6 \text{ kg}$   
 Initial pressure of each constituent,  
 $p_{O_2} = p_{N_2} = 103 \text{ kPa}$

We know that number of moles of oxygen,

$$n_{O_2} = \frac{\text{Mass of oxygen } (m_{O_2})}{\text{Molecular mass of oxygen } (M_{O_2})} = \frac{2}{32} = 0.0625$$

and number of moles of nitrogen,

$$n_{N_2} = \frac{m_{N_2}}{M_{N_2}} = \frac{6}{28} = 0.2143$$

Total number of moles in the mixture,

$$n = n_{O_2} + n_{N_2} = 0.0625 + 0.2143 = 0.2768$$

We know that mole fraction of oxygen,

$$x_{O_2} = \frac{n_{O_2}}{n} = \frac{p_{O_2}}{p} = \frac{0.0625}{0.2768} = 0.2258$$

and mole fraction of nitrogen,

$$x_{N_2} = \frac{n_{N_2}}{n} = \frac{p_{N_2}}{p} = \frac{0.2143}{0.2768} = 0.7742$$

We know that increase in entropy,

$$\begin{aligned} ds &= -2.3 n_{O_2} R_u \log \left( \frac{p_{O_2}}{p} \right) - 2.3 n_{N_2} R_u \log \left( \frac{p_{N_2}}{p} \right) \\ &= -2.3 \times 0.0625 \times 8.314 \log (0.2258) - 2.3 \times 0.2143 \times 8.314 \log (0.7742) \\ &= 0.7724 + 0.4555 = 1.2279 \text{ kJ/kg Ans.} \end{aligned}$$

### VOLUMETRIC ANALYSIS AND GRAVIMETRIC ANALYSIS

The mixture of gases may be analysed either on the volumetric basis or on mass basis (*i.e.* gravimetric basis). Such analysis are called *volumetric analysis* and *gravimetric analysis* respectively. In order to convert the volumetric analysis of a gas mixture into mass or gravimetric analysis, first of all multiply the volume of each constituent to its own molecular mass to obtain the mass of that constituent. Add up these masses to obtain the total mass of the mixture. Now divide the mass of each constituent to the total mass of the mixture which gives the mass fraction of each constituent. The procedure is best explained in the following example.

**Example 11.9.** A mixture of gases has the following volumetric composition:

$$CO_2 = 12\%; O_2 = 4\%; N_2 = 82\%; CO = 2\%$$

Calculate: 1. Gravimetric composition; 2. Molecular mass of the mixture; and 3. Gas constant for the mixture.

**Solution.**

Given: Volume of carbon dioxide ( $CO_2$ ) in  $1 \text{ m}^3$  of the mixture =  $12\% = 0.12$

Volume of oxygen ( $O_2$ ) =  $4\% = 0.04$

Volume of nitrogen ( $N_2$ ) =  $82\% = 0.82$

Volume of carbon monoxide ( $CO$ ) =  $2\% = 0.02$

1. *Gravimetric composition*

We have already discussed in Art. 11.4 that the volume fraction ( $z$ ) is equal to the mole fraction ( $x$ ).

We also know that \*mass of the constituent per mole of the mixture

$$= x \times M, \text{ where } M \text{ is the molecular mass of the constituent.}$$

Using these relations, the results may be tabulated as follows:

Constituent	% by volume or % by mole  (a)	**kg mole per mole of mixture or mole fraction or volume fraction ( $x$ )  (b)	Molecular mass ( $M$ )  (c)	Mass of the constituent per mole of the mixture $m = x \times M$  (d)	% Mass  $= \frac{(d)}{\Sigma(d)} \times 100$
$CO_2$	12	0.12	44	5.28	$\frac{5.28}{30.08} \times 100 = 17.55$
$O_2$	4	0.04	32	1.28	$\frac{1.28}{30.08} \times 100 = 4.26$
$N_2$	82	0.82	28	22.96	$\frac{22.96}{30.08} \times 100 = 76.33$
$CO$	2	0.02	28	0.56	$\frac{0.56}{30.08} \times 100 = 1.86$
<b>Total</b>	<b>100</b>	<b>1.00</b>		$\Sigma(d) = 30.08$	<b>100</b>

\* We know that mole fraction of the constituent (say  $x_a$ )

$$= \frac{\text{Number of moles of the constituent (say } n_a)}{\text{Total number of moles in the mixture } (n)} \quad \dots[\text{For constituent } a]$$

and mass of the constituent = Number of moles of the constituent  $\times$  Molecular mass of the constituent

$\therefore$  Mass of the constituent per mole of the mixture (*i.e.* when  $n = 1$ )

2. *Molecular mass of the mixture*

We know that molecular mass of the mixture

$$= \Sigma m = \Sigma (d) = 30.08 \text{ Ans.}$$

3. *Gas constant for the mixture*

$$R = \frac{R_u}{\Sigma m} = \frac{8.314}{30.08} = 0.2764 \text{ kJ/kg K Ans.}$$

**Example 11.10.** *A mixture of gases at a pressure of 4 bar has a temperature of 150°C. A sample is analysed and volumetric analysis is found to be*

$$CO_2 = 14\%; O_2 = 5\%; \text{ and } N_2 = 81\%$$

*Determine the gravimetric analysis and partial pressure of the gases in the mixture. If 2.3 kg of mixture is cooled at constant pressure to 15°C; find the final volume.*

**Solution.**

Given: Pressure of mixture of gases,

$$p = 4 \text{ bar} = 400 \text{ kN/m}^2$$

Temperature of mixture,  $T = 150^\circ\text{C}$

Volume of carbon dioxide (CO<sub>2</sub>) = 14% = 0.14

Volume of oxygen (O<sub>2</sub>) = 5% = 0.05

Volume of nitrogen (N<sub>2</sub>) = 81% = 0.81

*Gravimetric analysis*

As discussed in the previous example, the results of the gravimetric analysis are given in following table.

Constituent	% by volume or % by mole  (a)	Volume fraction or mole fraction (x)  (b)	Molecular mass (M)  (c)	Mass of the constituent per mole of the mixture $m = x \times M$ (d)	% Mass $\frac{(d)}{\Sigma(d)} \times 100$
CO <sub>2</sub>	14	0.14	44	6.16	$\frac{6.16}{30.44} \times 100 = 20.2$
O <sub>2</sub>	5	0.05	32	1.6	$\frac{1.6}{30.44} \times 100 = 5.3$
N <sub>2</sub>	81	0.81	28	22.68	$\frac{22.68}{30.44} \times 100 = 74.5$
<b>Total</b>	<b>100</b>	<b>1.00</b>		<b><math>\Sigma(d) = 30.44</math></b>	<b>100</b>

*Partial pressure of the gases in the mixture*

We know that volume fraction is equal to the mole fraction.

∴ Partial pressure of carbon dioxide,

$$p_{\text{CO}_2} = x_{\text{CO}_2} \times p = 0.14 \times 4 = 0.56 \text{ bar Ans.}$$

Partial pressure of oxygen,

$$p_{\text{O}_2} = x_{\text{O}_2} \times p = 0.05 \times 4 = 0.20 \text{ bar Ans.}$$

and partial pressure of nitrogen,

$$p_{\text{N}_2} = x_{\text{N}_2} \times p = 0.81 \times 4 = 3.24 \text{ bar Ans.}$$

*Final volume*

Given: Mass of the mixture,

$$m_{\text{mix}} = 2.3 \text{ kg}$$

Temperature,

$$T = 15^\circ\text{C} = 15 + 273 = 288 \text{ K}$$

We know that number of moles in the mixture,

$$n = \frac{\text{Mass of the mixture } (m_{\text{mix}})}{\text{Total mass of the constituents per mole of the mixture } (\Sigma d)}$$

$$= \frac{2.3}{30.44} = 0.0756$$

Using the gas equation, we have

$$pv = n R_u T$$

∴

$$v = \frac{n R_u T}{p} = \frac{0.0756 \times 8.314 \times 288}{400} = 0.453 \text{ m}^3 \text{ Ans.}$$

#### **Atmospheric Air:**

Atmospheric air makes up the environment in almost every type of air conditioning system. Hence a thorough understanding of the properties of atmospheric air and the ability to analyze various processes involving air is fundamental to air conditioning design.

Psychrometry is the study of the properties of mixtures of air and water vapour.

Atmospheric air is a mixture of many gases plus water vapour and a number of pollutants. The amount of water vapour and pollutants vary from place to place. The concentration of water vapour and pollutants decrease with altitude, and above an altitude of about 10 km, atmospheric air consists of only dry air. The pollutants have to be filtered out before processing the air. Hence, what we process is essentially a mixture of various gases that constitute air and water vapour. This mixture is known as moist air.

**Psychrometric Properties:**

Dry bulb temperature (DBT) is the temperature of the moist air as measured by a standard thermometer or other temperature measuring instruments.

Saturated vapour pressure (psat) is the saturated partial pressure of water vapour at the dry bulb temperature. This is readily available in thermodynamic tables and charts.

ASHRAE suggests the following regression equation for saturated vapour pressure of water, which is valid for 0 to 100°C.

Relative humidity (Φ) is defined as the ratio of the mole fraction of water vapour in moist air to mole fraction of water vapour in saturated air at the same temperature and pressure. Using perfect gas equation we can show that:

$$\phi = \frac{\text{partial pressure of water vapour}}{\text{saturation pressure of pure water vapour at same temperature}} = \frac{p_v}{p_{sat}}$$

Relative humidity is normally expressed as a percentage. When Φ is 100 percent, the air is saturated.

Humidity ratio (W): The humidity ratio (or specific humidity) W is the mass of water associated with each kilogram of dry air<sup>1</sup>. Assuming both water vapour and dry air to be perfect gases<sup>2</sup>, the humidity ratio is given by:

$$W = \frac{\text{kg of water vapour}}{\text{kg of dry air}} = \frac{p_v V / R_v T}{p_a V / R_a T} = \frac{p_v / R_v}{(p_t - p_v) / R_a}$$

Substituting the values of gas constants of water vapour and air R<sub>v</sub> and R<sub>a</sub> in the above equation; the humidity ratio is given by:

$$W = 0.622 \frac{p_v}{p_t - p_v}$$

For a given barometric pressure p<sub>t</sub>, given the DBT, we can find the saturated vapour pressure p<sub>sat</sub> from the thermodynamic property tables on steam. Then using the above equation, we can find the humidity ratio at saturated conditions, W<sub>sat</sub>.

It is to be noted that, W is a function of both total barometric pressure and vapor pressure of water.

Dew-point temperature: If unsaturated moist air is cooled at constant pressure, then the temperature at which the moisture in the air begins to condense is known as dew-point temperature (DPT) of air. An approximate equation for dew-point temperature is given by:

$$DPT = \frac{4030(DBT + 235)}{4030 - (DBT + 235)\ln\phi} - 235$$

where  $\phi$  is the relative humidity (in fraction). DBT & DPT are in °C. Of course, since from its definition, the dew point temperature is the saturation temperature corresponding to the vapour pressure of water vapour, it can be obtained from steam tables

Degree of saturation  $\mu$ : The degree of saturation is the ratio of the humidity ratio  $W$  to the humidity ratio of a saturated mixture  $W_s$  at the same temperature and pressure, i.e.,

$$\mu = \left| \frac{W}{W_s} \right|_{t,P}$$

Enthalpy: The enthalpy of moist air is the sum of the enthalpy of the dry air and the enthalpy of the water vapour. Enthalpy values are always based on some reference value. For moist air, the enthalpy of dry air is given a zero value at 0°C, and for water vapour the enthalpy of saturated water is taken as zero at 0°C.

The enthalpy of moist air is given by:

$$h = h_a + Wh_g = c_p t + W(h_{fg} + c_{pw} t)$$

where  $c_p$  = specific heat of dry air at constant pressure, kJ/kg.K  
 $c_{pw}$  = specific heat of water vapor, kJ/kg.K  
 $t$  = Dry-bulb temperature of air-vapor mixture, °C  
 $W$  = Humidity ratio, kg of water vapor/kg of dry air  
 $h_a$  = enthalpy of dry air at temperature  $t$ , kJ/kg  
 $h_g$  = enthalpy of water vapor<sup>3</sup> at temperature  $t$ , kJ/kg  
 $h_{fg}$  = latent heat of vaporization at 0°C, kJ/kg

The unit of  $h$  is kJ/kg of dry air. Substituting the approximate values of  $c_p$  and  $h_g$ , we obtain:

$$h = 1.005 t + W(2501 + 1.88t)$$

Humid specific heat: From the equation for enthalpy of moist air, the humid specific heat of moist air can be written as:

$$c_{pm} = c_p + W.c_{pw}$$

where  $c_{pm}$  = humid specific heat, kJ/kg.K  
 $c_p$  = specific heat of dry air, kJ/kg.K  
 $c_{pw}$  = specific heat of water vapor, kJ/kg  
 $W$  = humidity ratio, kg of water vapor/kg of dry air

Since the second term in the above equation ( $w.c_{pw}$ ) is very small compared to the first term, for all practical purposes, the humid specific heat of moist air,  $c_{pm}$  can be taken as 1.0216 kJ/kg dry air.K

Specific volume: The specific volume is defined as the number of cubic meters of moist air per kilogram of dry air. From perfect gas equation since the volumes occupied by the individual substances are the same, the specific volume is also equal to the number of cubic meters of dry air per kilogram of dry air, i.e.,

$$v = \frac{R_a T}{P_a} = \frac{R_a T}{P_t - P_v} \quad \text{m}^3 / \text{kg dry air}$$

### Psychrometric chart

A *Psychrometric chart* graphically represents the thermodynamic properties of moist air. Standard psychrometric charts are bounded by the dry-bulb temperature line (abscissa) and the vapour pressure or humidity ratio (ordinate). The Left Hand Side of the psychrometric chart is bounded by the saturation line. Figure 27.2 shows the schematic of a psychrometric chart. Psychrometric charts are readily available for standard barometric pressure of 101.325 kPa at sea level and for normal temperatures (0-50°C). ASHRAE has also developed psychrometric charts for other temperatures and barometric pressures (for low temperatures: -40 to 10°C, high temperatures 10 to 120°C and very high temperatures 100 to 120°C)

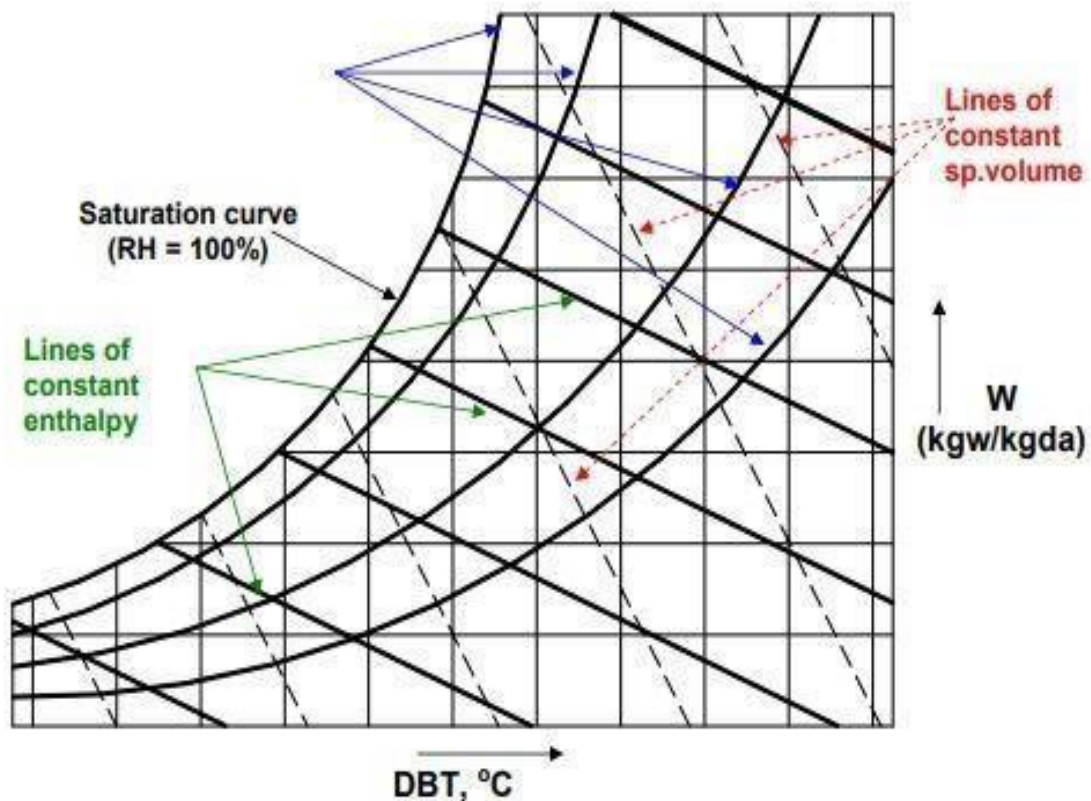

Figure 27.2 Schematic of a psychrometric chart for a given barometric pressure

### Measurement of psychrometric properties:

Based on Gibbs' phase rule, the thermodynamic state of moist air is uniquely fixed if the barometric pressure and two other independent properties are known. This means that at a given barometric pressure, the state of moist air can be determined by measuring any two independent properties. One of them could be the dry-bulb temperature (DBT), as the measurement of this temperature is fairly simple and accurate. The accurate measurement of other independent parameters such as humidity ratio is very difficult in practice. Since measurement of temperatures is

easier, it would be convenient if the other independent parameter is also a temperature. Of course, this could be the dew-point temperature (DPT), but it is observed that accurate measurement of dew-point temperature is difficult. In this context, a new independent temperature parameter called the *wet-bulb temperature* (WBT) is defined. Compared to DPT, it is easier to measure the wet-bulb temperature of moist air. Thus knowing the dry-bulb and wet-bulb temperatures from measurements, it is possible to find the other properties of moist air.

To understand the concept of wet-bulb temperature, it is essential to understand the process of combined heat and mass transfer.

#### **Combined heat and mass transfer; the straight line law**

The straight line law states that “*when air is transferring heat and mass (water) to or from a wetted surface, the condition of air shown on a psychrometric chart drives towards the saturation line at the temperature of the wetted surface*”.

For example, as shown in Fig.27.3, when warm air passes over a wetted surface its temperature drops from 1 to 2. Also, since the vapor pressure of air at 1 is greater than the saturated vapor pressure at  $t_w$ , there will be moisture transfer from air to water, i.e., the warm air in contact with cold wetted surface cools and dehumidifies. According to the straight line law, the final condition of air (i.e., 2) lies on a straight line joining 1 with  $t_w$  on the saturation line. This is due to the value of unity of the Lewis number, that was discussed in an earlier chapter on analogy between heat and mass transfer.

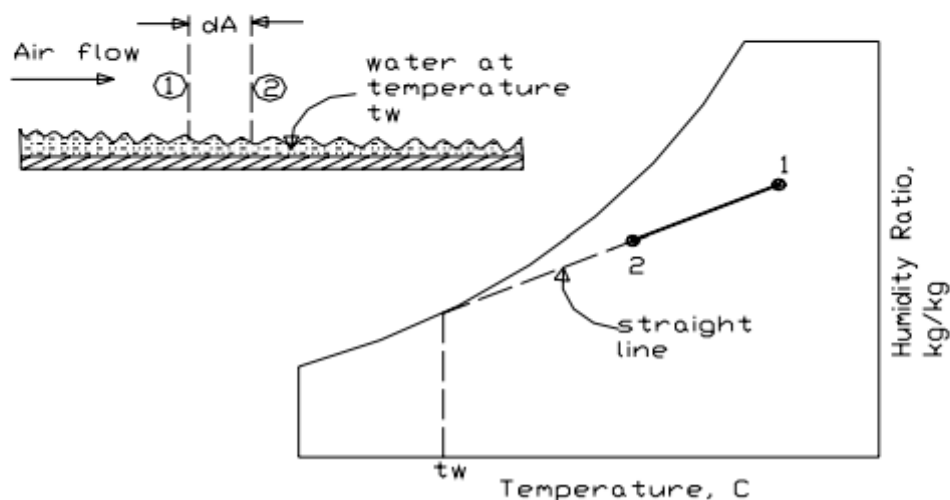

**Fig.27.3: Principle of straight-line law for air-water mixtures**

#### **Adiabatic saturation and thermodynamic wet bulb temperature:**

Adiabatic saturation temperature is defined as that temperature at which water, by evaporating into air, can bring the air to saturation at the same temperature adiabatically. An adiabatic saturator is a device using which one can measure theoretically the adiabatic saturation temperature of air.

As shown in Fig.27.4, an adiabatic saturator is a device in which air flows through an infinitely long duct containing water. As the air comes in contact with

water in the duct, there will be heat and mass transfer between water and air. If the duct is infinitely long, then at the exit, there would exist perfect equilibrium between air and water at steady state. Air at the exit would be fully saturated and its temperature is equal to that of water temperature. The device is adiabatic as the walls of the chamber are thermally insulated. In order to continue the process, make-up water has to be provided to compensate for the amount of water evaporated into the air. The temperature of the make-up water is controlled so that it is the same as that in the duct.

After the adiabatic saturator has achieved a steady-state condition, the temperature indicated by the thermometer immersed in the water is the thermodynamic wet-bulb temperature. The thermodynamic wet bulb temperature will be less than the entering air DBT but greater than the dew point temperature.

Certain combinations of air conditions will result in a given sump temperature, and this can be defined by writing the energy balance equation for the adiabatic saturator. Based on a unit mass flow rate of dry air, this is given by:

$$h_1 = h_2 - (W_2 - W_1)h_f$$

where  $h_f$  is the enthalpy of saturated liquid at the sump or thermodynamic wet-bulb temperature,  $h_1$  and  $h_2$  are the enthalpies of air at the inlet and exit of the adiabatic saturator, and  $W_1$  and  $W_2$  are the humidity ratio of air at the inlet and exit of the adiabatic saturator, respectively.

It is to be observed that the thermodynamic wet-bulb temperature is a thermodynamic property, and is independent of the path taken by air. Assuming the humid specific heat to be constant, from the enthalpy balance, the thermodynamic wet-bulb temperature can be written as:

$$t_2 = t_1 - \frac{h_{fg,2}}{c_{pm}} (w_2 - w_1)$$

where  $h_{fg,2}$  is the latent heat of vaporization at the saturated condition 2. Thus measuring the dry bulb ( $t_1$ ) and wet bulb temperature ( $t_2$ ) one can find the inlet humidity ratio ( $W_1$ ) from the above expression as the outlet saturated humidity ratio ( $W_2$ ) and latent heat of vaporizations are functions of  $t_2$  alone (at fixed barometric pressure).

On the psychrometric chart as shown in Fig.27.4, point 1 lies below the line of constant enthalpy that passes through the saturation point 2.  $t_2 = f(t_1, W_1)$  is not a unique function, in the sense that there can be several combinations of  $t_1$  and  $W_1$  which can result in the same sump temperature in the adiabatic saturator. A line passing through all these points is a constant wet bulb temperature line. Thus all inlet conditions that result in the same sump temperature, for example point 1' have the same wet bulb temperature. The line is a straight line according to the straight-line law. The straight-line joining 1 and 2 represents the path of the air as it passes through the adiabatic saturator.

Normally lines of constant wet bulb temperature are shown on the psychrometric chart. The difference between actual enthalpy and the enthalpy obtained by following constant wet-bulb temperature is equal to  $(W_2 - W_1)h_f$ .

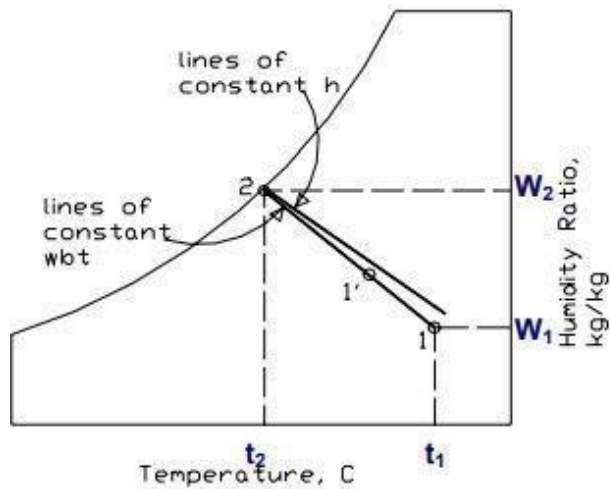
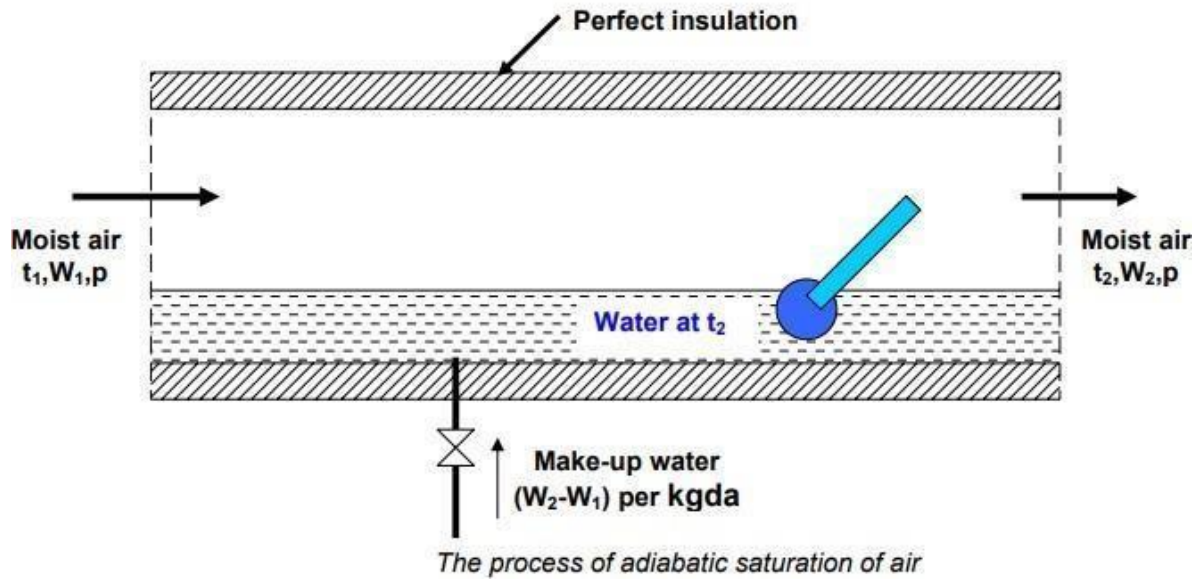

*Adiabatic saturation process 1-2 on psychrometric chart*

**Wet-Bulb Thermometer:**

In practice, it is not convenient to measure the wet-bulb temperature using an adiabatic saturator. In stead, a thermometer with a wetted wick is used to measure the wet bulb temperature as shown in Fig.27.6. It can be observed that since the area of the wet bulb is finite, the state of air at the exit of the wet bulb will not be saturated, in stead it will be point 2 on the straight line joining 1 and  $i$ , provided the temperature of water on the wet bulb is  $i$ . It has been shown by Carrier, that this is a valid assumption for air-water mixtures. Hence for air-water mixtures, one can assume that the temperature measured by the wet-bulb thermometer is equal to the thermodynamic wet-bulb temperature<sup>4</sup>. For other gas-vapor mixtures, there can be appreciable difference between the thermodynamic and actual wet-bulb temperatures.

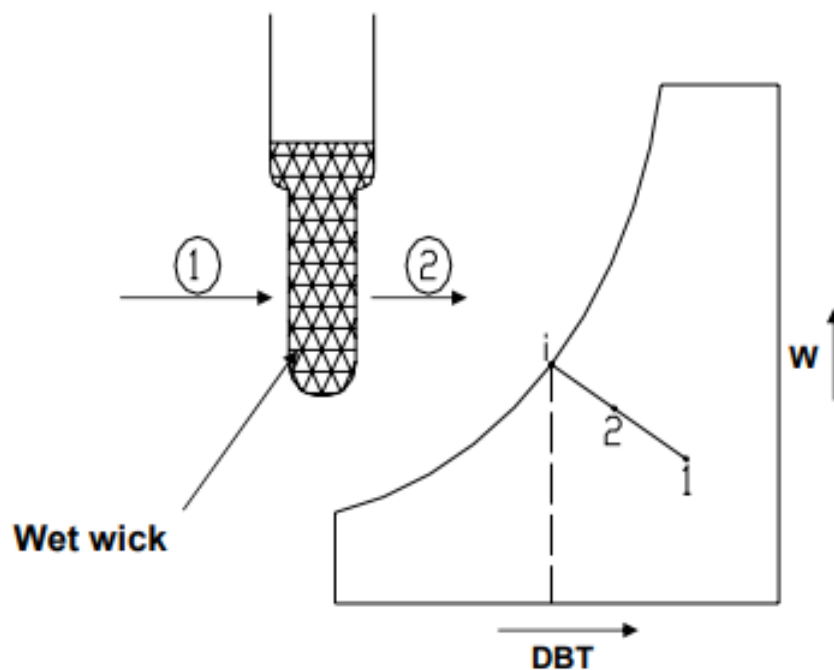

*Schematic of a wet-bulb thermometer and the process on psychrometric chart*

## Calculation of psychrometric properties from p, DBT and WBT:

As mentioned before, to fix the thermodynamic state of moist air, we need to know three independent properties. The properties that are relatively easier to measure, are: the barometric pressure, dry-bulb temperature and wet-bulb temperature. For a given barometric pressure, knowing the dry bulb and wet bulb temperatures, all other properties can be easily calculated from the psychrometric equations. The following are the empirical relations for the vapor pressure of water in moist air:

i) Modified Apjohn equation:

$$p_v = p_v' - \frac{1.8p(t - t')}{2700} \quad (27.15)$$

ii) Modified Ferrel equation:

$$p_v = p_v' - 0.00066p(t - t') \left[ 1 + \frac{1.8t}{1571} \right] \quad (27.16)$$

iii) Carrier equation:

$$p_v = p_v' - \frac{1.8(p - p_v')(t - t')}{2800 - 1.3(1.8t + 32)} \quad (27.17)$$

where t = dry bulb temperature, °C  
 t' = wet bulb temperature, °C  
 p = barometric pressure  
 p<sub>v</sub> = vapor pressure  
 p<sub>v</sub>' = saturation vapor pressure at wet-bulb temperature

The units of all the pressures in the above equations should be consistent.

Once the vapor pressure is calculated, then all other properties such as relative humidity, humidity ratio, enthalpy, humid volume etc. can be calculated from the psychrometric equations presented earlier.

### Psychrometer:

Any instrument capable of measuring the psychrometric state of air is called a psychrometer. As mentioned before, in order to measure the psychrometric state of air, it is required to measure three independent parameters. Generally two of these are the barometric pressure and air dry-bulb temperature as they can be measured easily and with good accuracy.

Two types of psychrometers are commonly used. Each comprises of two thermometers with the bulb of one covered by a moist wick. The two sensing bulbs are separated and shaded from each other so that the radiation heat transfer between them becomes negligible. Radiation shields may have to be used over the bulbs if the surrounding temperatures are considerably different from the air temperature.

The *sling psychrometer* is widely used for measurements involving room air or other applications where the air velocity inside the room is small. The sling psychrometer consists of two thermometers mounted side by side and fitted in a frame with a handle for whirling the device through air. The required air circulation ( $\approx 3$  to  $5$  m/s) over the sensing bulbs is obtained by whirling the psychrometer ( $\approx 300$  RPM). Readings are taken when both the thermometers show steady-state readings.

In the *aspirated psychrometer*, the thermometers remain stationary, and a small fan, blower or syringe moves the air across the thermometer bulbs.

The function of the wick on the wet-bulb thermometer is to provide a thin film of water on the sensing bulb. To prevent errors, there should be a continuous film of water on the wick. The wicks made of cotton or cloth should be replaced frequently, and only distilled water should be used for wetting it. The wick should extend beyond the bulb by 1 or 2 cms to minimize the heat conduction effects along the stem.

Other types of psychrometric instruments:

1. Dunmore Electric Hygrometer
2. DPT meter
3. Hygrometer (Using horse's or human hair)

5. On a particular day the weather forecast states that the dry bulb temperature is  $37^\circ\text{C}$ , while the relative humidity is 50% and the barometric pressure is 101.325 kPa. Find the humidity ratio, dew point temperature and enthalpy of moist air on this day.

**Ans.:**

At  $37^\circ\text{C}$  the saturation pressure ( $p_s$ ) of water vapour is obtained from steam tables as **6.2795 kPa**.

Since the relative humidity is 50%, the vapour pressure of water in air ( $p_v$ ) is:

$$p_v = 0.5 \times p_s = 0.5 \times 6.2795 = 3.13975 \text{ kPa}$$

the humidity ratio  $W$  is given by:

$$W = 0.622 \times p_v / (p_t - p_v) = 0.622 \times 3.13975 / (101.325 - 3.13975) = 0.01989 \text{ kgw/kgda}$$

(Ans.)

The enthalpy of air ( $h$ ) is given by the equation:

$$h = 1.005t + W(2501 + 1.88t) = 1.005 \times 37 + 0.01989(2501 + 1.88 \times 37) = 88.31 \text{ kJ/kgda}$$

(Ans.)

7. Moist air at 1 atm. pressure has a dry bulb temperature of 32°C and a wet bulb temperature of 26°C. Calculate a) the partial pressure of water vapour, b) humidity ratio, c) relative humidity, d) dew point temperature, e) density of dry air in the mixture, f) density of water vapour in the mixture and g) enthalpy of moist air using perfect gas law model and psychrometric equations.

**Ans.:**

a) Using modified Apjohn equation and the values of DBT, WBT and barometric pressure, the vapour pressure is found to be:

$$p_v = 2.956 \text{ kPa} \quad (\text{Ans.})$$

b) The humidity ratio  $W$  is given by:

$$W = 0.622 \times 2.956 / (101.325 - 2.956) = 0.0187 \text{ kgw/kgda} \quad (\text{Ans.})$$

c) Relative humidity  $RH$  is given by:

$$RH = (p_v / p_s) \times 100 = (p_v / \text{saturation pressure at } 32^\circ\text{C}) \times 100$$

From steam tables, the saturation pressure of water at 32°C is 4.7552 kPa, hence,

$$RH = (2.956 / 4.7552) \times 100 = 62.16\% \quad (\text{Ans.})$$

d) Dew point temperature is the saturation temperature of steam at 2.956 kPa. Hence using steam tables we find that:

$$DPT = T_{\text{sat}}(2.956 \text{ kPa}) = 23.8^\circ\text{C} \quad (\text{Ans.})$$

e) Density of dry air and water vapour

Applying perfect gas law to dry air:

$$\begin{aligned} \text{Density of dry air } \rho_a &= (p_a / R_a T) = (p_t - p_v) / R_a T = (101.325 - 2.956) / (287.035 \times 305) \times 10^3 \\ &= 1.1236 \text{ kg/m}^3 \text{ of dry air} \quad (\text{Ans.}) \end{aligned}$$

f) Similarly the density of water vapour in air is obtained using perfect gas law as:

$$\begin{aligned} \text{Density of water vapour } \rho_v &= (p_v / R_v T) = 2.956 \times 10^3 / (461.52 \times 305) = 0.021 \text{ kg/m}^3 \\ & \quad (\text{Ans.}) \end{aligned}$$

g) Enthalpy of moist air is found from the equation:

$$\begin{aligned} h &= 1.005 \times t + W(2501 + 1.88 \times t) = 1.005 \times 32 + 0.0187(2501 + 1.88 \times 32) \\ h &= 80.05 \text{ kJ/kg of dry air} \quad (\text{Ans.}) \end{aligned}$$

## UNIT-V

### Gas Power Cycles

#### Introduction

For the purpose of thermodynamic analysis of the internal combustion engines, the following approximations are made:

- The engine is assumed to operate on a closed cycle with a fixed mass of air which does not undergo any chemical change.
- The combustion process is replaced by an equivalent energy addition process from an external source.
- The exhaust process is replaced by an equivalent energy rejection process to external surroundings by means of which the working fluid is restored to the initial state.
- The air is assumed to behave like an ideal gas with constant specific heat. These cycles are usually referred to as air standard cycle.

#### Otto Cycle

The Air Standard Otto cycle is named after its inventor **Nikolaus A. Otto**. Figures 5.1 (a), (b) and (c) illustrate the working principles of an Otto cycle. The Otto cycle consists of the following processes.

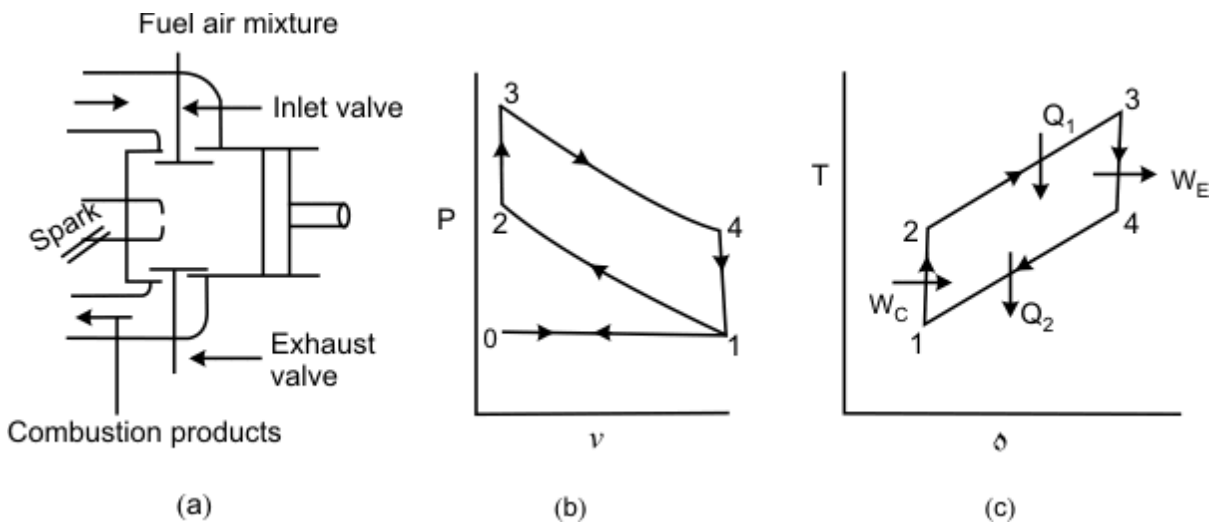

Figure 5.1

0-1: Constant pressure suction during which a mixture of fuel vapour and air is drawn into the cylinder as the piston executes an outward stroke.

1-2: The mixture is compressed isentropically due to the inward motion of the piston. Because of the **isentropic compression**, the temperature of the gas increases.

2-3: The hot fuel vapour-air mixture is ignited by means of an electric spark. Since the combustion is instantaneous, there is not enough time for the piston to move outward. This process is approximated as a **constant volume energy addition process**.

3-4: The hot combustion products undergo **isentropic expansion** and the piston executes an outward motion.

4-1: The exhaust port opens and the combustion products are exhausted into the atmosphere. The process is conveniently approximated as a **constant-volume energy rejection process**.

1-0: The remaining combustion products are exhausted by an inward motion of the piston at constant pressure.

Effectively there are four strokes in the cycle. These are suction, compression, expansion, and exhaust strokes, respectively. From the P-V diagram it can be observed that the work done during the process 0-1 is exactly balanced by the work done during 1-0. Hence for the purpose of thermodynamic analysis we need to consider only the cycle 1-2-3-4, which is air- standard Otto Cycle.

$$\eta = \frac{W_{net}}{Q_1} = \frac{(Q_1 - Q_2)}{Q_1} \quad (5.1)$$

Where  $Q_1$  and  $Q_2$  denote the energy absorbed and energy rejected in the form of heat. Application of the first law of thermodynamics to process 2-3 and 4-1 gives:

$$Q_1 = U_3 - U_2 = m(u_3 - u_2) = mc_v (T_3 - T_2) \quad (5.2)$$

$$Q_2 = U_4 - U_1 = m(u_4 - u_1) = mc_v (T_4 - T_1) \quad (5.3)$$

Therefore,

$$\eta = 1 - \frac{T_4 - T_1}{T_3 - T_2} \quad (5.4)$$

1-2 and 3-4 are isentropic processes for which  $TV^{\gamma-1} = \text{constant}$

Therefore,

$$\frac{T_1}{T_2} = \left(\frac{V_2}{V_1}\right)^{\gamma-1} \quad \text{or} \quad \frac{T_2}{T_1} = \left(\frac{V_1}{V_2}\right)^{\gamma-1} \quad (5.5)$$

and

$$\frac{T_3}{T_4} = \left(\frac{V_4}{V_3}\right)^{\gamma-1} \quad (5.6)$$

But

$$V_1 = V_4 \quad \text{and} \quad V_2 = V_3 \quad (5.7)$$

Hence

$$\frac{T_3}{T_4} = \left(\frac{V_1}{V_2}\right)^{\gamma-1} \quad (5.8)$$

So,

$$\frac{T_2}{T_1} = \frac{T_3}{T_4} \quad \text{or} \quad \frac{T_3}{T_2} = \frac{T_4}{T_1} \quad (5.9)$$

$$\frac{T_3}{T_2} - 1 = \frac{T_4}{T_1} - 1 \quad (5.10)$$

or

$$\frac{T_3 - T_2}{T_2} = \frac{T_4 - T_1}{T_1} \quad \text{or} \quad \frac{T_4 - T_1}{T_3 - T_2} = \frac{T_1}{T_2} \quad (5.11)$$

and

$$\frac{T_1}{T_2} = \left(\frac{V_2}{V_1}\right)^{\gamma-1} = \left(\frac{1}{r_0}\right)^{\gamma-1} \quad (5.12)$$

$$\eta = 1 - \left(\frac{1}{r_0}\right)^{\gamma-1} \quad (5.13)$$

Where

$$r_0 = \frac{V_1}{V_2} = \text{Compression ratio} \quad (5.14)$$

Since  $\eta$ , the efficiency of the Otto cycle increases with increasing compression ratio. However, in an actual engine, the compression ratio can not be increased indefinitely since higher compression ratios give higher values of  $T_2$  and this leads to **spontaneous** and **uncontrolled** combustion of the gasoline-air mixture in the cylinder. Such a condition is usually called knocking.

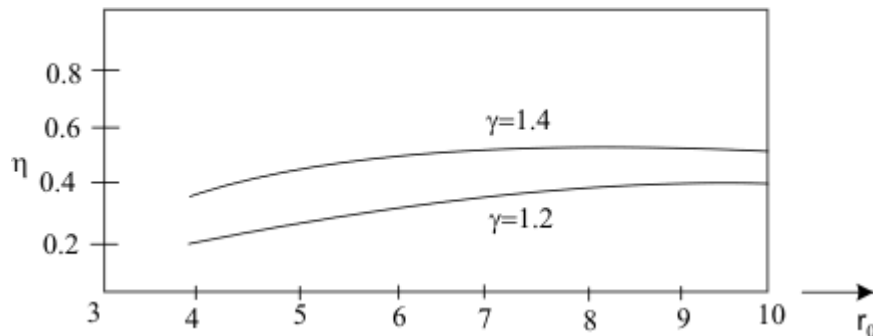

Figure 5.2

Performance of an engine is evaluated in terms of the efficiency (see Figure 5.2). However, sometime it is convenient to describe the performance in terms of mean effective pressure, an imaginary pressure obtained by equating the cycle work to the work evaluated by the following relation

$$W_{net} = P_m \int dV = P_m (V_1 - V_2) \quad (5.15)$$

The mean effective pressure is defined as the net work divided by the displacement volume.

That is

$$P_m = \frac{W_{net}}{(V_1 - V_2)}$$

## DIESEL CYCLE

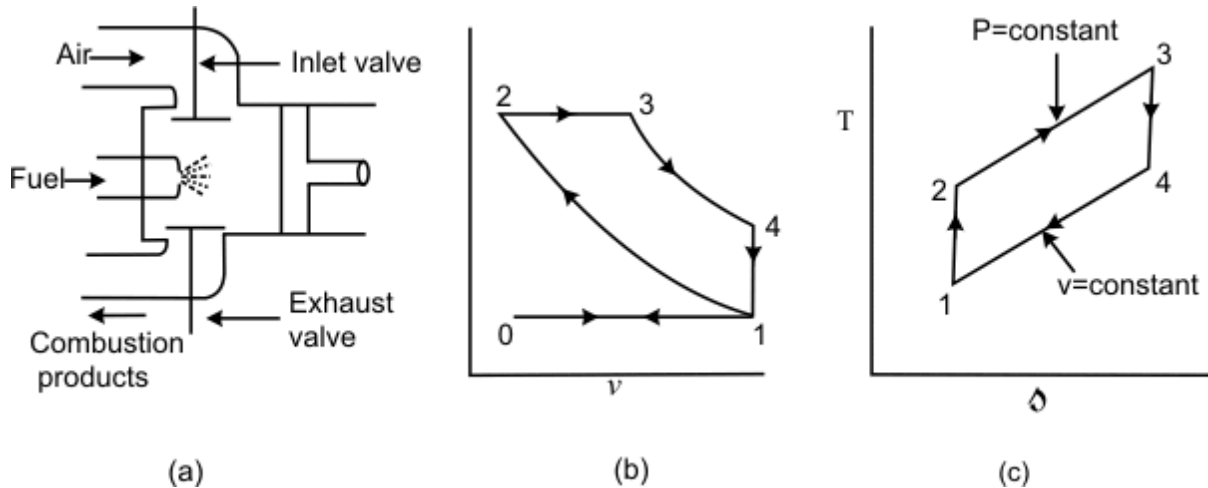

Figure 5.3 (a), (b) and (c)

The Diesel cycle was developed by Rudolf Diesel in Germany. Figures 5.3 (a), (b) and (c) explain the working principle of an Air Standard Diesel cycle. The following are the processes.

0-1: Constant pressure suction during which fresh air is drawn into the cylinder as the piston executes the outward motion.

1-2: The air is compressed isentropically. Usually the compression ratio in the **Diesel cycle is much higher than that of Otto cycle**. Because of the high compression ratio, the temperature of the gas at the end of isentropic compression is so high that when fuel is injected, it gets ignited immediately.

2-3: The fuel is injected into the hot compressed air at state 2 and the fuel undergoes a chemical reaction. The combustion of Diesel oil in air is not as spontaneous as the combustion of gasoline and the combustion is relatively slow. Hence the piston starts moving outward as combustion takes place. The combustion process is conveniently approximated as a **constant pressure energy addition process**.

3-4: The combustion products undergo isentropic expansion and the piston executes an outward motion.

4-1: The combustion products are exhausted at constant volume when the discharge port opens. This is replaced by a **constant-volume energy rejection process**.

1-0: The remaining combustion products are exhausted at constant pressure by the inward motion of the piston.

In the analysis of a Diesel cycle, two important parameters are: compression ratio ( $r_0 = V_1/V_2$ ) and the cut-off ratio ( $r_c$ ). The cut-off ratio is defined as the ratio of the volume at the end of constant-pressure energy addition process to the volume at the beginning of the energy addition process.

$$r_c = \frac{V_3}{V_2} \quad (5.16)$$

$$\text{Energy added} = Q_1 = mc_p (T_3 - T_2) \quad (5.17)$$

$$\text{Energy rejected} = Q_2 = mc_v (T_4 - T_1) \quad (5.18)$$

$$\eta = \frac{Q_1 - Q_2}{Q_1} = 1 - \frac{T_4 - T_1}{\gamma(T_3 - T_2)} \quad (5.19)$$

or

$$\eta = 1 - \frac{\{(T_4/T_1) - 1\} T_1}{\{(T_3/T_2) - 1\} \gamma T_2} \quad (5.20)$$

1-2 is Isentropic:

$$\frac{T_1}{T_2} = \left(\frac{V_2}{V_1}\right)^{\gamma-1} = \left(\frac{1}{r_0}\right)^{\gamma-1}$$

**4-1 is Constant volume:**

$$\frac{T_4}{T_1} = \frac{P_4}{P_1} = \frac{P_4}{P_3} \times \frac{P_3}{P_1}$$

But  $P_2 = P_3$

Hence

$$\frac{T_4}{T_1} = \frac{P_4}{P_3} \times \frac{P_2}{P_1}$$

Since 1–2 and 3–4 are isentropic processes ( $PV^\gamma = C$ )

$$\frac{P_4}{P_3} = \left(\frac{V_3}{V_4}\right)^\gamma \quad \text{and} \quad \frac{P_2}{P_1} = \left(\frac{V_1}{V_2}\right)^\gamma$$

Hence

$$\frac{T_4}{T_1} = \left(\frac{V_3}{V_4}\right)^\gamma \left(\frac{V_1}{V_2}\right)^\gamma = \left(\frac{V_3}{V_2}\right)^\gamma = (r_c)^\gamma \quad (5.21)$$

$$\eta = 1 - \frac{\{(r_c)^\gamma - 1\}}{\gamma (r_0)^{\gamma-1} \{r_c - 1\}} \quad (5.22)$$

Also to be noted

$$\frac{T_3}{T_2} = \frac{P_3 V_3}{P_2 V_2} = \frac{V_3}{V_2} = r_c \quad (5.23)$$

The compression ratios normally in the Diesel engines vary between 14 and 17.

### AIR STANDARD DUAL CYCLE

Figures 5.4 (a) and (b) shows the working principles of a Dual cycle. In the dual cycle, the energy addition is accomplished in two stages: Part of the energy is added at constant volume and part of the energy is added at constant pressure. The remaining processes are similar to those of the Otto cycle and the Diesel cycle. The efficiency of the cycle can be estimated in the following way

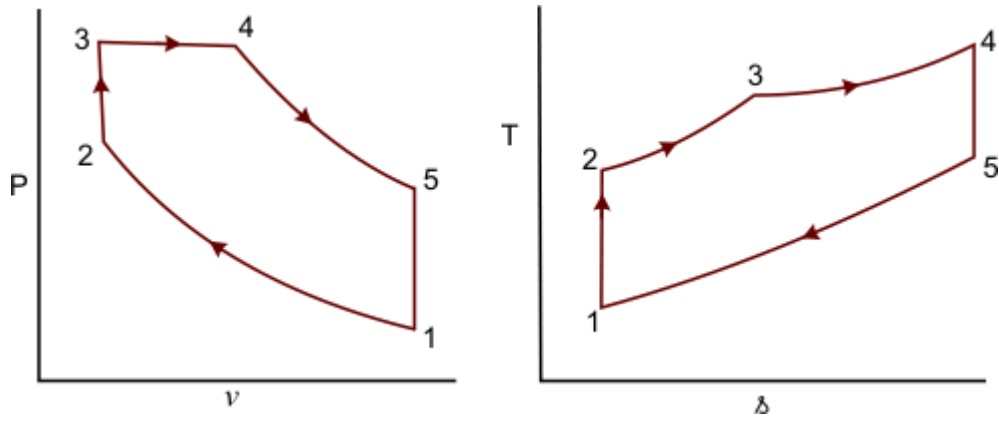

Figure 5.4.1 (a) and (b)

Energy added

$$q_1 = c_v(T_3 - T_2) + c_p(T_4 - T_3) \quad (5.24)$$

Energy rejected

$$q_2 = c_v(T_5 - T_1) \quad (5.25)$$

$$\eta = 1 - \frac{c_v(T_5 - T_1)}{c_v(T_3 - T_2) + c_p(T_4 - T_3)} \quad (5.25)$$

or

$$\eta = 1 - \frac{(T_5 - T_1)}{(T_3 - T_2) + \gamma(T_4 - T_3)} \quad (5.26)$$

The efficiency of the cycle can be expressed in terms of the following ratios

Compression ratio,  $r_0 = \frac{V_1}{V_2}$  (5.27)

Cut-off ratio,  $r_c = \frac{V_4}{V_3}$  (5.28)

Expansion ratio,  $r_e = \frac{V_5}{V_4}$  (5.28)

Constant volume pressure ratio,  $r_{vp} = \frac{P_3}{P_2}$  (5.29)

$$\eta_{Dual} = 1 - \frac{1}{(r_0)^{\gamma-1}} \frac{r_{vp} (r_c)^\gamma - 1}{(r_{vp} - 1) + \gamma r_{vp} (r_c - 1)}$$
 (5.30)

I  $r_c = 1, \eta_{Dual} \rightarrow \eta_{Otto}$

f  $r_{vp} = 1, \eta_{Dual} \rightarrow \eta_{Diesel}$

I

f

**Comparison of Otto, Diesel & Dual Cycles**

**For same compression ratio and heat rejection (Figures 5.5 (a) and (b))**

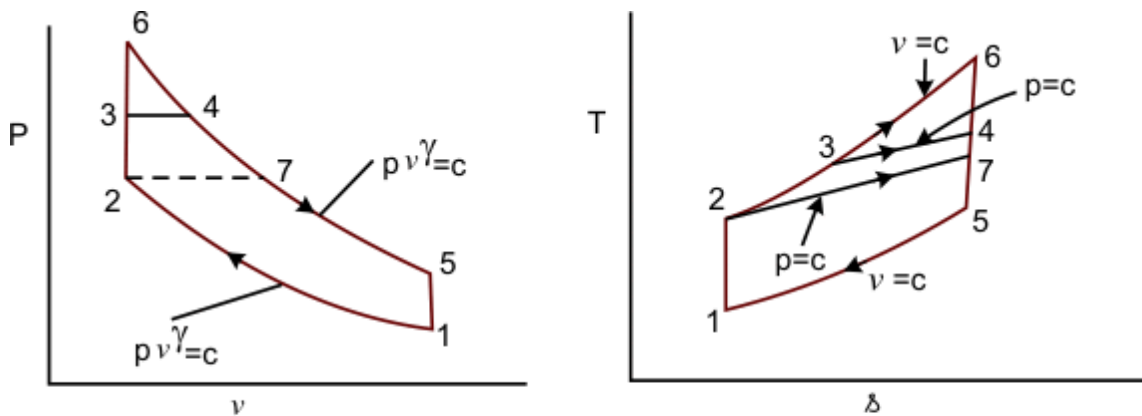

(a)

(b)

**Figure 5.5 (a) and (b)**

1-6-4-5: Otto cycle

1-7-4-5: Diesel cycle

1-2-3-4-5 Dual cycle

For the same  $Q_2$ , the higher the  $Q_1$ , the higher is the cycle efficiency

$$\eta_{Otto} > \eta_{Dual} > \eta_{Diesel}$$

For the same maximum pressure and temperature (Figures 5.6 (a) and (b))

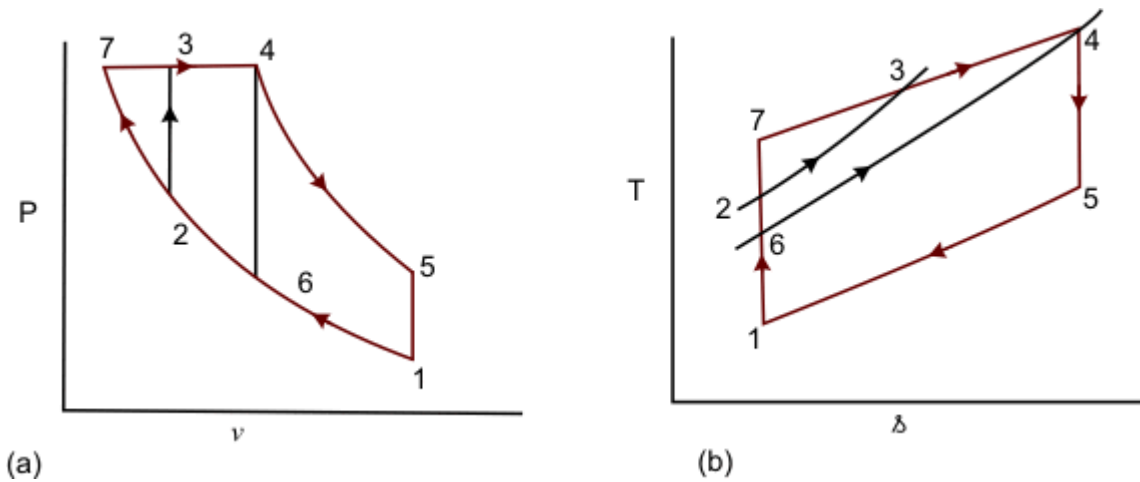

Figure 5.6 (a) and (b)

1-6-4-5: Otto cycle

1-7-4-5: Diesel cycle

1-2-3-4-5 Dual cycle

$Q_1$  is represented by:

Area under 6-4  $\rightarrow$  for Otto cycle  
 area under 7-4  $\rightarrow$  for Diesel cycle

and  
 area under 2-3-4  $\rightarrow$  for Dual cycle and  $Q_2$  is same for all the cycles

$$\eta_{Diesel} > \eta_{Dual} > \eta_{Otto}$$

**THE RANKINE CYCLE**

The Rankine cycle is an ideal cycle for vapour power cycles. Many of the impracticalities

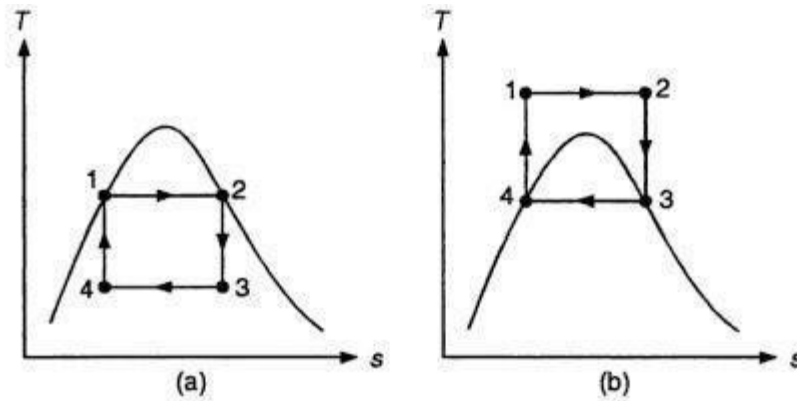

Figure 9.1  $T$ - $s$  diagram of two Carnot vapour cycles.

associated with the Carnot cycle can be eliminated by superheating the steam in the boiler and condensing it completely in the condenser, as shown in Fig. 9.2. The processes involved are:

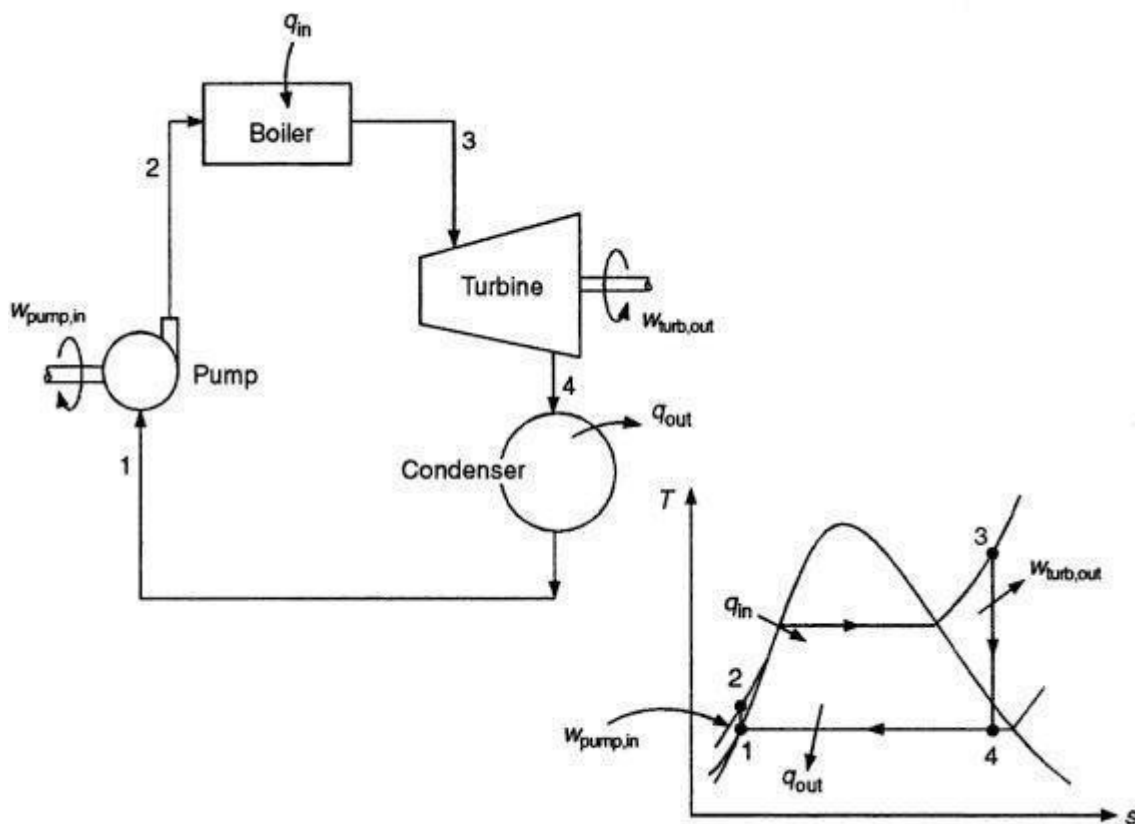

Figure 9.2 The Rankine cycle.

isentropic compression in a pump (1–2), constant pressure heat addition in a boiler (2–3), isentropic expansion in a turbine (3–4), and constant pressure heat rejection in a condenser (4–1). The cycle that results in these processes is the *Rankine cycle*.

The pump, boiler, and condenser associated with a Rankine cycle are steady-flow devices, and thus all the processes of this cycle can be analysed as steady-flow processes. The  $\Delta ke$  and

**Example 3.30.** (a) With the help of  $p-v$  and  $T-s$  diagram compare the cold air standard otto, diesel and dual combustion cycles for same maximum pressure and maximum temperature. (AMIE Summer, 1998)

**Solution.** Refer Fig. 3.29. (a, b).

The air-standard Otto, Dual and Diesel cycles are drawn on common  $p-v$  and  $T-s$  diagrams for the same maximum pressure and maximum temperature, for the purpose of comparison.

Otto 1-2-3-4-1, Dual 1-2'-3'-3-4-1, Diesel 1-2''-3-4-1 (Fig 3.29 (a)).

Slope of constant volume lines on  $T-s$  diagram is higher than that of constant pressure lines. (Fig. 3.29 (b)).

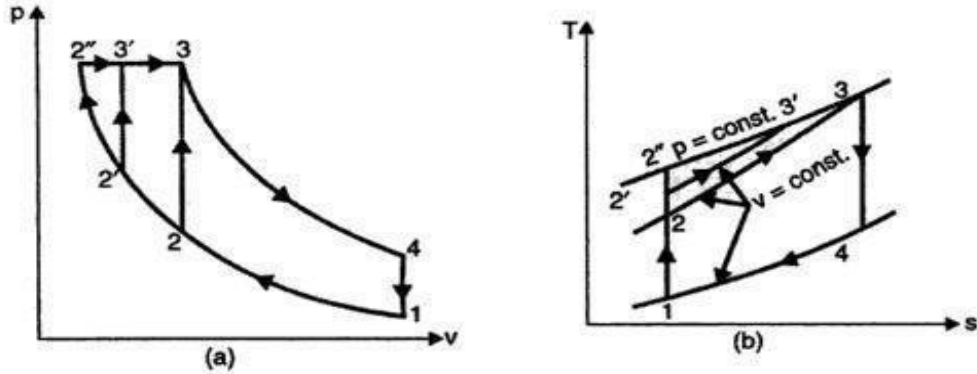

Fig. 3.29

Here the otto cycle must be limited to a low compression ratio ( $r$ ) to fulfill the condition that point 3 (same maximum pressure and temperature) is to be a common state for all the three cycles.

The construction of cycles on  $T-s$  diagram proves that for the given conditions the heat rejected is same for all the three cycles (area under process line 4-1). Since, by definition,

$$\eta = 1 - \frac{\text{Heat rejected, } Q_r}{\text{Heat supplied, } Q_s} = 1 - \frac{\text{Const.}}{Q_s}$$

the cycle, with greater heat addition will be more efficient. From the  $T-s$  diagram,

$$Q_{s(\text{diesel})} = \text{Area under } 2''-3$$

$$Q_{s(\text{dual})} = \text{Area under } 2'-3'-3$$

$$Q_{s(\text{otto})} = \text{Area under } 2-3.$$

It can be seen that,  $Q_{s(\text{diesel})} > Q_{s(\text{dual})} > Q_{s(\text{otto})}$

and thus,  $\eta_{\text{diesel}} > \eta_{\text{dual}} > \eta_{\text{otto}}$

In an engine working on Dual cycle, the temperature and pressure at the beginning of the cycle are  $90^\circ\text{C}$  and 1 bar respectively. The compression ratio is 9. The maximum pressure is limited to 68 bar and total heat supplied per kg of air is 1750 kJ. Determine :

- (i) Pressure and temperatures at all salient points
- (ii) Air standard efficiency
- (iii) Mean effective pressure.

**Solution.** Refer Fig. 3.22.

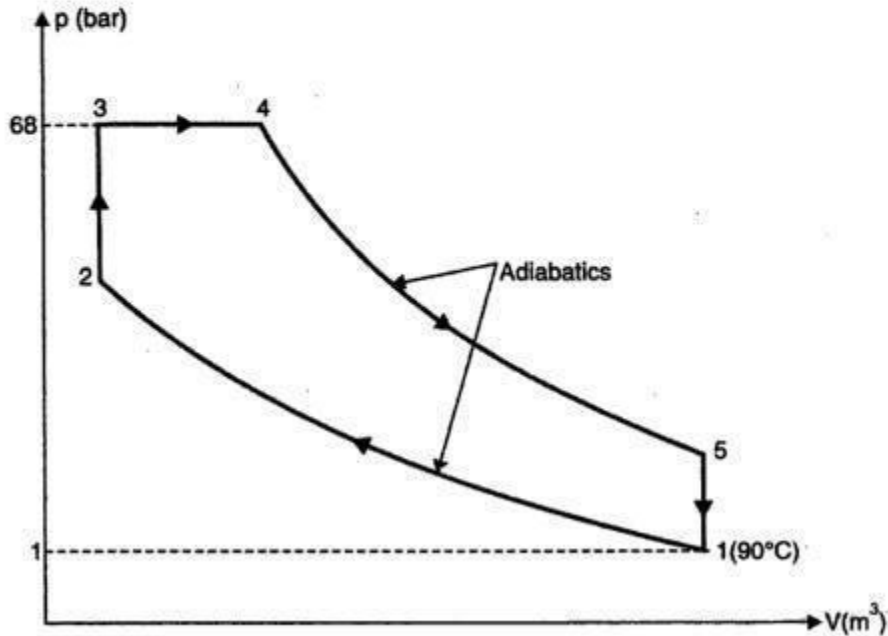

Fig. 3.22

Initial pressure,  $p_1 = 1$  bar  
 Initial temperature,  $T_1 = 90 + 273 = 363$  K  
 Compression ratio,  $r = 9$   
 Maximum pressure,  $p_3 = p_4 = 68$  bar  
 Total heat supplied  $= 1750$  kJ/kg

(i) Pressures and temperatures at salient points :

For the isentropic process 1-2,

$$p_1 V_1^\gamma = p_2 V_2^\gamma$$

$$p_2 = p_1 \times \left(\frac{V_1}{V_2}\right)^\gamma = 1 \times (r)^\gamma = 1 \times (9)^{1.4} = 21.67 \text{ bar. (Ans.)}$$

Also,

$$\frac{T_2}{T_1} = \left(\frac{V_1}{V_2}\right)^{\gamma-1} = (r)^{\gamma-1} = (9)^{1.4-1} = 2.408$$

∴

$$T_2 = T_1 \times 2.408 = 363 \times 2.408 = 874.1 \text{ K. (Ans.)}$$

$$p_3 = p_4 = 68 \text{ bar. (Ans.)}$$

For the constant volume process 2-3,

$$\frac{P_2}{T_2} = \frac{P_3}{T_3}$$

$$\therefore T_3 = T_2 \times \frac{P_3}{P_2} = 874.1 \times \frac{68}{21.67} = 2742.9 \text{ K. (Ans.)}$$

Heat added at constant volume

$$= c_v (T_3 - T_2) = 0.71 (2742.9 - 874.1) = 1326.8 \text{ kJ/kg}$$

$\therefore$  Heat added at constant pressure

$$= \text{Total heat added} - \text{Heat added at constant volume} \\ = 1750 - 1326.8 = 423.2 \text{ kJ/kg}$$

$$\therefore c_p (T_4 - T_3) = 423.2 \\ 1.0(T_4 - 2742.9) = 423.2$$

$$\therefore T_4 = 3166 \text{ K. (Ans.)}$$

For constant pressure process 3-4,

$$\rho = \frac{V_4}{V_3} = \frac{T_4}{T_3} = \frac{3166}{2742.9} = 1.15$$

For adiabatic (or isentropic) process 4-5,

$$\frac{V_5}{V_4} = \frac{V_5}{V_2} \times \frac{V_2}{V_4} = \frac{V_1}{V_2} \times \frac{V_3}{V_4} = \frac{r}{\rho} \quad \left( \because \rho = \frac{V_4}{V_3} \right)$$

Also

$$P_4 V_4^\gamma = P_5 V_5^\gamma$$

$$\therefore P_5 = P_4 \times \left( \frac{V_4}{V_5} \right)^\gamma = 68 \times \left( \frac{\rho}{r} \right)^\gamma = 68 \times \left( \frac{1.15}{9} \right)^{1.4} = 3.81 \text{ bar. (Ans.)}$$

$$\text{Again, } \frac{T_5}{T_4} = \left( \frac{V_4}{V_5} \right)^{\gamma-1} = \left( \frac{\rho}{r} \right)^{\gamma-1} = \left( \frac{1.15}{9} \right)^{1.4-1} = 0.439$$

$$\therefore T_5 = T_4 \times 0.439 = 3166 \times 0.439 = 1389.8 \text{ K. (Ans.)}$$

(ii) Air standard efficiency :

Heat rejected during constant volume process 5-1,

$$Q_r = C_v (T_5 - T_1) = 0.71(1389.8 - 363) = 729 \text{ kJ/kg}$$

$$\therefore \eta_{\text{air-standard}} = \frac{\text{Work done}}{\text{Heat supplied}} = \frac{Q_s - Q_r}{Q_s} \\ = \frac{1750 - 729}{1750} = 0.5834 \text{ or } 58.34\%. \text{ (Ans.)}$$

(iii) Mean effective pressure,  $p_m$  :

Mean effective pressure is given by

$$p_m = \frac{\text{Work done per cycle}}{\text{Stroke volume}}$$

$$p_m = \frac{1}{V_s} \left[ P_3 (V_4 - V_3) + \frac{P_4 V_4 - P_5 V_5}{\gamma - 1} - \frac{P_2 V_2 - P_1 V_1}{\gamma - 1} \right]$$

$$V_1 = V_5 = r V_c, V_2 = V_3 = V_c, V_4 = \rho V_c, \\ V_s = (r - 1) V_c$$

$$\left[ \because r = \frac{V_s + V_c}{V_c} = 1 + \frac{V_s}{V_c} \right] \\ \left[ \therefore V_s = (r - 1) V_c \right]$$

$$\therefore p_m = \frac{1}{(r-1)V_c} \left[ p_3 (\rho V_c - V_c) + \frac{p_4 \rho V_c - p_5 \times r V_c}{\gamma - 1} - \frac{p_2 V_c - p_1 r V_c}{\gamma - 1} \right]$$

$$r = 9, \rho = 1.15, \gamma = 1.4$$

$$p_1 = 1 \text{ bar}, p_2 = 21.67 \text{ bar}, p_3 = p_4 = 68 \text{ bar}, p_5 = 3.81 \text{ bar}$$

Substituting the above values in the above equation, we get

$$p_m = \frac{1}{(9-1)} \left[ 68(1.15-1) + \frac{68 \times 1.15 - 3.81 \times 9}{1.4-1} - \frac{21.67-9}{1.4-1} \right]$$

$$= \frac{1}{8} (10.2 + 109.77 - 31.67) = 11.04 \text{ bar}$$

Hence, mean effective pressure = 11.04 bar. (Ans.)

A Diesel engine working on a dual combustion cycle has a stroke volume of  $0.0085 \text{ m}^3$  and a compression ratio  $15 : 1$ . The fuel has a calorific value of  $43890 \text{ kJ/kg}$ . At the end of suction, the air is at  $1 \text{ bar}$  and  $100^\circ\text{C}$ . The maximum pressure in the cycle is  $65 \text{ bar}$  and air fuel ratio is  $21 : 1$ . Find for ideal cycle the thermal efficiency. Assume  $c_p = 1.0 \text{ kJ/kg K}$  and  $c_v = 0.71 \text{ kJ/kg K}$ .

**Solution.** Refer Fig. 3.24.

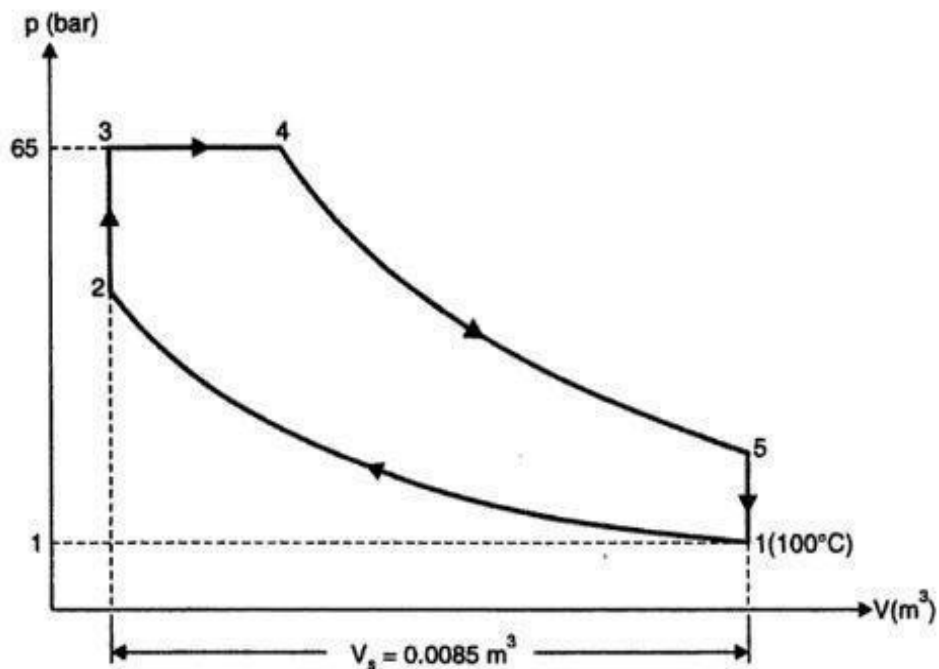

Fig. 3.24

Initial temperature,  
Initial pressure,

$$T_1 = 100 + 273 = 373 \text{ K}$$

$$p_1 = 1 \text{ bar}$$

Maximum pressure in the cycle,  $p_3 = p_4 = 65 \text{ bar}$

Stroke volume,  $V_s = 0.0085 \text{ m}^3$

Air-fuel ratio  $= 21 : 1$

Compression ratio,  $r = 15 : 1$

Calorific value of fuel,  $C = 43890 \text{ kJ/kg}$

$c_p = 1.0 \text{ kJ/kg K}$ ,  $c_v = 0.71 \text{ kJ/kg K}$

**Thermal efficiency :**

$$V_s = V_1 - V_2 = 0.0085 \text{ m}^3$$

and as

$$r = \frac{V_1}{V_2} = 15, \text{ then } V_1 = 15V_2$$

$$\therefore 15V_2 - V_2 = 0.0085$$

or

$$14V_2 = 0.0085$$

or

$$V_2 = V_3 = V_c = \frac{0.0085}{14} = 0.0006 \text{ m}^3$$

For *adiabatic compression process 1-2*,

$$p_1 V_1^\gamma = p_2 V_2^\gamma$$

or

$$p_2 = p_1 \cdot \left( \frac{V_1}{V_2} \right)^\gamma = 1 \times (15)^{1.41} \quad \left[ \gamma = \frac{c_p}{c_v} = \frac{1.0}{0.71} = 1.41 \right]$$

$$= 45.5 \text{ bar}$$

Also,

$$\frac{T_2}{T_1} = \left( \frac{V_1}{V_2} \right)^{\gamma-1} = (r)^{\gamma-1} = (15)^{1.41-1} = 3.04$$

$\therefore$

$$T_2 = T_1 \times 3.04 = 373 \times 3.04 = 1134 \text{ K or } 861^\circ\text{C}$$

For *constant volume process 2-3*,

$$\frac{p_2}{T_2} = \frac{p_3}{T_3}$$

or

$$T_3 = T_2 \times \frac{p_3}{p_2} = 1134 \times \frac{65}{45.5} = 1620 \text{ K or } 1347^\circ\text{C}$$

According to characteristic equation of gas,

$$p_1 V_1 = mRT_1$$

$\therefore$

$$m = \frac{p_1 V_1}{RT_1} = \frac{1 \times 10^5 \times 0.009}{287 \times 373} = 0.0084 \text{ kg (air)}$$

*Heat added during constant volume process 2-3*,

$$= m \times c_v (T_3 - T_2)$$

$$= 0.0084 \times 0.71 (1620 - 1134)$$

$$= 2.898 \text{ kJ}$$

Amount of fuel added during the *constant volume process 2-3*,

$$= \frac{2.898}{43890} = 0.000066 \text{ kg}$$

Also as air-fuel ratio is 21 : 1.

$$\therefore \text{Total amount of fuel added} = \frac{0.0084}{21} = 0.0004 \text{ kg}$$

$$\begin{aligned} \text{Quantity of fuel added during the process 3-4,} \\ = 0.0004 - 0.000066 = 0.000334 \text{ kg} \end{aligned}$$

$$\begin{aligned} \therefore \text{Heat added during the constant pressure operation 3-4} \\ = 0.000334 \times 43890 = 14.66 \text{ kJ} \end{aligned}$$

$$\begin{aligned} \text{But } (0.0084 + 0.0004) c_p (T_4 - T_3) &= 14.66 \\ 0.0088 \times 1.0 (T_4 - 1620) &= 14.66 \end{aligned}$$

$$\therefore T_4 = \frac{14.66}{0.0088} + 1620 = 3286 \text{ K or } 3013^\circ\text{C}$$

Again for operation 3-4,

$$\frac{V_3}{T_3} = \frac{V_4}{T_4} \quad \text{or} \quad V_4 = \frac{V_3 T_4}{T_3} = \frac{0.0006 \times 3286}{1620} = 0.001217 \text{ m}^3$$

For adiabatic expansion operation 4-5,

$$\frac{T_4}{T_5} = \left( \frac{V_5}{V_4} \right)^{\gamma-1} = \left( \frac{0.009}{0.001217} \right)^{1.41-1} = 2.27$$

or

$$T_5 = \frac{T_4}{2.27} = \frac{3286}{2.27} = 1447.5 \text{ K or } 1174.5^\circ\text{C}$$

Heat rejected during constant volume process 5-1,

$$\begin{aligned} &= m c_v (T_5 - T_1) \\ &= (0.00854 + 0.0004) \times 0.71 (1447.5 - 373) = 6.713 \text{ kJ} \end{aligned}$$

Work done

$$\begin{aligned} &= \text{Heat supplied} - \text{Heat rejected} \\ &= (2.898 + 14.66) - 6.713 = 10.845 \text{ kJ} \end{aligned}$$

$\therefore$  Thermal efficiency,

$$\eta_{th} = \frac{\text{Work done}}{\text{Heat supplied}} = \frac{10.845}{(2.898 + 14.66)} = 0.6176 \text{ or } 61.76\%. \quad (\text{Ans.})$$

**EXAMPLE 9.1**

A steam power plant operates between a boiler pressure of 4 MPa and 300°C and a condenser pressure of 50 kPa. Determine the thermal efficiency of the cycle, the work ratio, and the specific steam flow rate, assuming (a) the cycle to be a Carnot cycle, and (b) a simple ideal Rankine cycle.

**Solution**

(a) The  $T-s$  diagram of a Carnot cycle is shown in the adjacent figure.

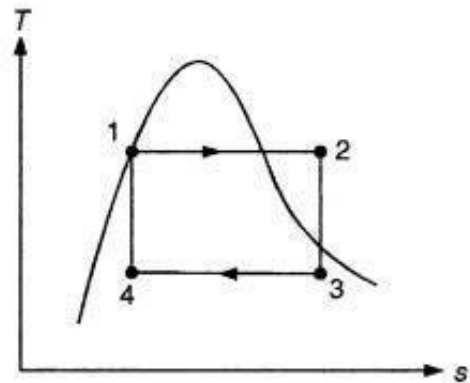

Process 1–2 is reversible and isothermal heating of water in the boiler.

Process 2–3 is isentropic expansion of steam at state 2 in the turbine.

Process 3–4 is reversible and isothermal condensation of steam in the condenser.

Process 4–1 is isentropic compression of steam to initial state.

At state 1:  $P_1 = 4 \text{ MPa}$ ,  $T_1 = 300^\circ\text{C}$

At state 2:  $P_2 = 50 \text{ kPa}$ , the steam is in a saturated state.

From the saturated water-pressure table (Table 4 of the Appendix), at 50 kPa, we get  $T_2 = T_{\min} = T_{\text{sat}} = 81.33^\circ\text{C}$

$\Delta pe$  of the steam are usually small compared with the work and heat transfer terms and are, therefore, neglected. Thus, the steady-flow energy equation per unit mass of steam is

$$q - w = h_e - h_i \quad (\text{kJ/kg}) \tag{9.1}$$

Assuming the pump and turbine to be isentropic and noting that there is no work associated with the boiler and the condenser, the energy conservation relation for each device becomes

$$w_{\text{pump,in}} = h_2 - h_1 = v(P_2 - P_1) \tag{9.2}$$

$$q_{\text{boi,in}} = h_3 - h_2 \tag{9.3}$$

$$w_{\text{turb,out}} = h_3 - h_4 \tag{9.4}$$

$$q_{\text{cond,out}} = h_4 - h_1 \tag{9.5}$$

The thermal efficiency of the Rankine cycle is given by

$$\eta_{\text{th}} = \frac{w_{\text{net}}}{q_{\text{in}}} = 1 - \frac{q_{\text{out}}}{q_{\text{in}}} \tag{9.6}$$

where  $w_{\text{net}} = q_{\text{in}} - q_{\text{out}} = w_{\text{turb,out}} - w_{\text{pump,in}}$

The  $\eta_{\text{th}}$  can also be interpreted as the ratio of the area enclosed by the cycle on a  $T-s$  diagram to the area under the heat addition process.

Therefore, the thermal efficiency for the given Carnot cycle is

$$\eta_{th,carnot} = 1 - \frac{T_{min}}{T_{max}} = 1 - \frac{81.33 + 273.15}{300 + 273.15} = 0.3815$$

$$= \boxed{38.15 \text{ per cent}}$$

The work ratio =  $\frac{\text{net work output}}{\text{gross work output}} = \frac{W_{net,out}}{W_{gross,out}}$

Heat supplied =  $h_2 - h_1 = h_{fg} @ 4MPa = 1714.1 \text{ kJ/kg}$  (From Table 4 of the Appendix)

$$\eta_{th,carnot} = \frac{W_{net,out} - W_{net,in}}{\text{gross heat supplied}} = 0.3815$$

Therefore,

$$W_{net, out} - W_{net, in} = 0.3815 \times 1714.1 = 653.9 \text{ kJ/kg}$$

That is, the net work output = 653.9 kJ/kg.

To find the expansion work for the process 2–3,  $h_3$  is required.

From Table 4,  $h_2 = 2801.4 \text{ kJ/kg}$  and  $s_2 = s_3 = 6.0701 \text{ kJ/(kg K)}$

But  $s_3 = 6.0701 = s_{f3} + x_3 s_{fg3} = 1.0910 + x_3(7.5939 - 1.0910)$

or

$$x_3 = 0.766$$

Now,

$$h_3 = h_{f3} + x_3 h_{fg3} = 340.49 + 0.766(2645.9 - 340.49) = 2106.4 \text{ kJ/kg}$$

Therefore,

$$w_{32} = h_2 - h_3 = 2801.4 - 2106.4 = 695 \text{ kJ/kg}$$

That is, the gross work output,  $w_{gross,out} = 695 \text{ kJ/kg}$

Therefore,

$$\text{Work ratio} = \frac{W_{net,out}}{W_{gross,out}} = \frac{653.9}{695} = \boxed{0.94}$$

The specific steam flow rate (ssfr) is the steam flow required to develop unit power output. That is,

$$\text{ssfr} = \frac{\dot{m}_{\text{steam}}}{\dot{m}_s w_{out}} = \frac{1}{W_{net, out}}$$

$$= \frac{1}{653.9} = \boxed{0.00153 \text{ kg/kW}}$$

A steam power plant operates on the cycle shown below with 3 MPa and 400°C at the turbine inlet and 10 kPa at the turbine exhaust. The adiabatic efficiency of the turbine is 85 per cent and that of the pump is 80 per cent. Determine (a) the thermal efficiency of the cycle, and (b) the mass flow rate of the steam if the power output is 20 MW.

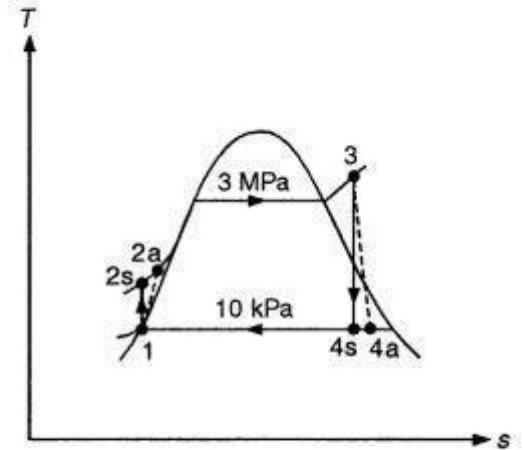
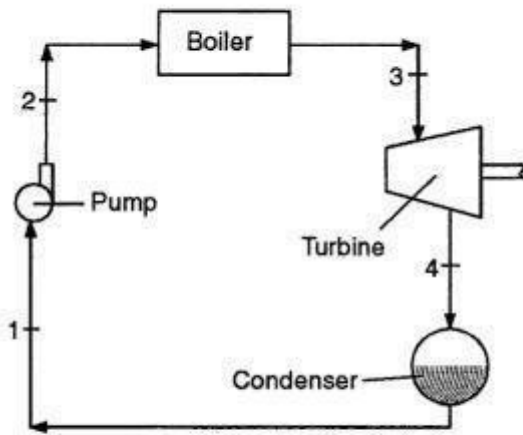

**Solution**

All the components are treated as steady-flow devices. The changes, if any, in the kinetic and potential energies are assumed to be negligible. Losses other than those in the turbine and pump are neglected.

$$(a) \quad w_{\text{pump,in}} = \frac{v_1(P_2 - P_1)}{\eta_P} = \frac{0.001010(3000 - 10)}{0.80} = 3.77 \text{ kJ/kg}$$

Turbine work output is

$$w_{\text{turb,out}} = \eta_T w_{\text{turb,in}} = \eta_T (h_3 - h_{4s})$$

$$= 0.85(3230.90 - 2192.21) = 882.89 \text{ kJ/kg}$$

Boiler heat input is

$$q_{\text{in}} = h_3 - h_2 = 3230.9 - 195.59 = 3035.31 \text{ kJ/kg}$$

Thus,

$$w_{\text{net,out}} = w_{\text{turb,out}} - w_{\text{pump,in}} = 882.89 - 3.77 = 879.12 \text{ kJ/kg}$$

$$\eta_{\text{th}} = \frac{w_{\text{net,out}}}{q_{\text{in}}} = \frac{879.12}{3035.31} = 0.2896 = \boxed{28.96 \text{ per cent}}$$

If there are no losses in the turbine and the pump, the thermal efficiency would be 28.99 per cent.

(b) The power generated by the power plant is

$$\dot{W}_{\text{net,out}} = \dot{m} w_{\text{net,out}} = 20,000 \text{ kW}$$

Therefore, the mass flow rate,  $\dot{m} = \frac{20,000}{879.12} = \boxed{22.75 \text{ kg/s}}$