

MECHANICS OF SOLIDS

COURSE FILE

III B. Tech I Semester

(2019-2020)

Prepared By

Dr. Ajith Raj R, Associate Professor

Department of Aeronautical Engineering



MALLA REDDY COLLEGE OF ENGINEERING & TECHNOLOGY

(Autonomous Institution – UGC, Govt. of India)

Affiliated to JNTU, Hyderabad, Approved by AICTE - Accredited by NBA & NAAC – 'A' Grade - ISO 9001:2015 Certified)

Maisammaguda, Dhulapally (Post Via. Kompally), Secunderabad – 500100, Telangana State, India.

MRCET VISION

- To become a model institution in the fields of Engineering, Technology and Management.
- To have a perfect synchronization of the ideologies of MRCET with challenging demands of International Pioneering Organizations.

MRCET MISSION

To establish a pedestal for the integral innovation, team spirit, originality and competence in the students, expose them to face the global challenges and become pioneers of Indian vision of modern society.

MRCET QUALITY POLICY.

- To pursue continual improvement of teaching learning process of Undergraduate and Post Graduate programs in Engineering & Management vigorously.
- To provide state of art infrastructure and expertise to impart the quality education.

PROGRAM OUTCOMES

(PO's)

Engineering Graduates will be able to:

1. **Engineering knowledge:** Apply the knowledge of mathematics, science, engineering fundamentals, and an engineering specialization to the solution of complex engineering problems.
2. **Problem analysis:** Identify, formulate, review research literature, and analyze complex engineering problems reaching substantiated conclusions using first principles of mathematics, natural sciences, and engineering sciences.
3. **Design / development of solutions:** Design solutions for complex engineering problems and design system components or processes that meet the specified needs with appropriate consideration for the public health and safety, and the cultural, societal, and environmental considerations.
4. **Conduct investigations of complex problems:** Use research-based knowledge and research methods including design of experiments, analysis and interpretation of data, and synthesis of the information to provide valid conclusions.
5. **Modern tool usage:** Create, select, and apply appropriate techniques, resources, and modern engineering and IT tools including prediction and modeling to complex engineering activities with an understanding of the limitations.
6. **The engineer and society:** Apply reasoning informed by the contextual knowledge to assess societal, health, safety, legal and cultural issues and the consequent responsibilities relevant to the professional engineering practice.
7. **Environment and sustainability:** Understand the impact of the professional engineering solutions in societal and environmental contexts, and demonstrate the knowledge of, and need for sustainable development.
8. **Ethics:** Apply ethical principles and commit to professional ethics and responsibilities and norms of the engineering practice.
9. **Individual and team work:** Function effectively as an individual, and as a member or leader in diverse teams, and in multidisciplinary settings.
10. **Communication:** Communicate effectively on complex engineering activities with the engineering community and with society at large, such as, being able to comprehend and write effective reports and design documentation, make effective presentations, and give and receive clear instructions.
11. **Project management and finance:** Demonstrate knowledge and understanding of the engineering and management principles and apply these to one's own work, as a member and leader in a team, to manage projects and in multi disciplinary environments.
12. **Life- long learning:** Recognize the need for, and have the preparation and ability to engage in independent and life-long learning in the broadest context of technological change.

DEPARTMENT OF AERONAUTICAL ENGINEERING

VISION

Department of Aeronautical Engineering aims to be indispensable source in Aeronautical Engineering which has a zeal to provide the value driven platform for the students to acquire knowledge and empower themselves to shoulder higher responsibility in building a strong nation.

MISSION

The primary mission of the department is to promote engineering education and research. To strive consistently to provide quality education, keeping in pace with time and technology. Department passions to integrate the intellectual, spiritual, ethical and social development of the students for shaping them into dynamic engineers.

QUALITY POLICY STATEMENT

Impart up-to-date knowledge to the students in Aeronautical area to make them quality engineers. Make the students experience the applications on quality equipment and tools. Provide systems, resources and training opportunities to achieve continuous improvement. Maintain global standards in education, training and services.

PROGRAM EDUCATIONAL OBJECTIVES – Aeronautical Engineering

1. **PEO1 (PROFESSIONALISM & CITIZENSHIP):** To create and sustain a community of learning in which students acquire knowledge and learn to apply it professionally with due consideration for ethical, ecological and economic issues.
2. **PEO2 (TECHNICAL ACCOMPLISHMENTS):** To provide knowledge based services to satisfy the needs of society and the industry by providing hands on experience in various technologies in core field.
3. **PEO3 (INVENTION, INNOVATION AND CREATIVITY):** To make the students to design, experiment, analyze, and interpret in the core field with the help of other multi disciplinary concepts wherever applicable.
4. **PEO4 (PROFESSIONAL DEVELOPMENT):** To educate the students to disseminate research findings with good soft skills and become a successful entrepreneur.
5. **PEO5 (HUMAN RESOURCE DEVELOPMENT):** To graduate the students in building national capabilities in technology, education and research

PROGRAM SPECIFIC OUTCOMES – Aeronautical Engineering

1. To mould students to become a professional with all necessary skills, personality and sound knowledge in basic and advance technological areas.
2. To promote understanding of concepts and develop ability in design manufacture and maintenance of aircraft, aerospace vehicles and associated equipment and develop application capability of the concepts sciences to engineering design and processes.
3. Understanding the current scenario in the field of aeronautics and acquire ability to apply knowledge of engineering, science and mathematics to design and conduct experiments in the field of Aeronautical Engineering.
4. To develop leadership skills in our students necessary to shape the social, intellectual, business and technical worlds.

MALLA REDDY COLLEGE OF ENGINEERING & TECHNOLOGY

II Year B. Tech, ANE-I Sem

L	T/P/D	C
3	1/-/-	3

R17A0363 - MECHANICS OF SOLIDS

Objectives:

- To introduce behavior of structural components under various loading conditions.
- To impart the knowledge of Shear force and Bending moment diagrams.

UNIT – I

Simple Stresses & Strains : Elasticity and plasticity – Types of stresses & strains–Hooke’s law– stress – strain diagram for mild steel – Working stress – Factor of safety – Lateral strain, Poisson’s ratio & volumetric strain – Elastic module & the relationship between them – Bars of varying section – compositebars – Temperature stresses. Strain energy – Resilience – Gradual, sudden, impact and shock loadings.

UNIT – II

Shear Force And Bending Moment : Definition of beam – Types of beams – Concept of shear force and bending moment – S.F and B.M diagrams for cantilever, simply supported and overhanging beams subjected to point loads, u.d.l., uniformly varying loads and combination of these loads – Point of contra flexure – Relation between S.F., B.M and rate of loading at a section of a beam.

UNIT – III

Flexural Stresses : Theory of simple bending – Assumptions – Derivation of bending equation: $M/I = f/y = E/R$ Neutral axis – Determination bending stresses – section modulus of rectangular and circular sections (Solid and Hollow), I,T,Angle and Channel sections – Design of simple beam sections. Shear Stresses: Derivation of formula – Shear stress distribution across various beams sections like rectangular, circular, triangular, I, T angle sections.

UNIT-IV

Principal Stresses and Strains: Introduction – Stresses on an inclined section of a bar under axial loading – compound stresses – Normal and tangential stresses on an inclined plane for biaxial stresses – Two perpendicular normal stresses accompanied by a state of simple shear – Mohr’s circle of stresses – Principal stresses and strains – Analytical and graphical solutions. Theories of Failure: Introduction – Various theories of failure - Maximum Principal Stress Theory, Maximum Principal Strain Theory, Strain Energy and Shear Strain Energy Theory (Von Mises Theory).

UNIT – V

Torsion of Circular Shafts : Theory of pure torsion – Derivation of Torsion equations : $T/J = q/r = N\theta/L$ – Assumptions made in the theory of pure torsion – Torsional moment of resistance – Polar section modulus – Power transmitted by shafts – Combined bending and torsion and end thrust – Design of shafts according to theories of failure.

Thin Cylinders: Thin seamless cylindrical shells – Derivation of formula for longitudinal and circumferential stresses – hoop, longitudinal and Volumetric strains – changes in dia, and volume of thin cylinders– Thin spherical shells.

Text Books:

1. Strength of materials – R.S. Kurmi and Gupta.
2. Solid Mechanics, by Popov
3. Strength of Materials – Ryder. G.H.; Macmillan Long Man Pub.
4. Strength of Materials – W.A. Nash, TMH

Reference Books:

1. Strength of Materials -By Jindal, Umesh Publications.
2. Analysis of structures by Vazirani and Ratwani.
3. Mechanics of Structures Vol –I by H.J.Shah and S.B.Junnarkar, Charotar Publishing House Pvt. Ltd.
4. Strength of Materials by D.S Prakash Rao, Universities Press Pvt. Ltd.
5. Strength of Materials by S.S.Rattan, Tata McGraw Hill Education Pvt. Ltd.
6. Fundamentals of Solid Mechancis by M.L.Gambhir, PHI Learning Pvt. Ltd
7. Strength of Materials by R.K Rajput, S.Chand & Company Ltd.

Outcomes:

- Understand the fundamental concepts of stress and strain in materials
 - Knowledge of beams and analysis of Shear Force and Bending moments
 - Apply the basic concepts to find the shear stress distribution and deflection in simply supported and Cantilever beam
 - Analysis of Elastic stability in columns under loading conditions
 - Knowledge on failure theories and factor of safety
-

UNIT – I

SIMPLE STRESSES AND STRAINS

INTRODUCTION AND REVIEW

Preamble

Engineering science is usually subdivided into number of topics such as

1. Solid Mechanics
2. Fluid Mechanics
3. Heat Transfer
4. Properties of materials and soon Although there are close links between them in terms of the physical principles involved and methods of analysis employed.

The solid mechanics as a subject may be defined as a branch of applied mechanics that deals with behaviours of solid bodies subjected to various types of loadings. This is usually subdivided into further two streams i.e Mechanics of rigid bodies or simply Mechanics and Mechanics of deformable solids.

The mechanics of deformable solids which is branch of applied mechanics is known by several names i.e. strength of materials, mechanics of materials etc.

Mechanics of rigid bodies:

The mechanics of rigid bodies is primarily concerned with the static and dynamic behaviour under external forces of engineering components and systems which are treated as infinitely strong and undeformable. Primarily we deal here with the forces and motions associated with particles and rigid bodies.

Mechanics of deformable solids :

Mechanics of solids:

The mechanics of deformable solids is more concerned with the internal forces and associated changes in the geometry of the components involved. Of particular importance are the properties of the materials used, the strength of which will determine whether the components fail by breaking in service, and the stiffness of which will determine whether the amount of deformation they suffer is acceptable. Therefore, the subject of mechanics of materials or strength of materials is central to the whole activity of engineering design. Usually the objectives in analysis here will be the determination of the stresses, strains, and deflections produced by loads. Theoretical analyses and experimental results have an equal roles in this field.

Analysis of stress and strain :

Concept of stress : Let us introduce the concept of stress as we know that the main problem of engineering mechanics of material is the investigation of the internal resistance of the body, i.e. the nature of forces set up within a body to balance the effect of the externally applied forces.

The externally applied forces are termed as loads. These externally applied forces may be due to any one of the reason.

- (i) due to service conditions
- (ii) due to environment in which the component works
- (iii) through contact with other members
- (iv) due to fluid pressures
- (v) due to gravity or inertia forces.

As we know that in mechanics of deformable solids, externally applied forces acts on a body and body suffers a deformation. From equilibrium point of view, this action should be opposed or reacted by internal forces which are set up within the particles of material due to cohesion.

These internal forces give rise to a concept of stress. Therefore, let us define a stress Therefore, let us define a term stress

Stress:

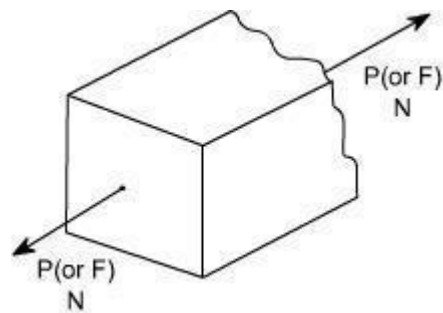

Let us consider a rectangular bar of some cross – sectional area and subjected to some load or force (in Newtons)

Let us imagine that the same rectangular bar is assumed to be cut into two halves at section XX. The each portion of this rectangular bar is in equilibrium under the action of load P and the internal forces acting at the section XX has been shown

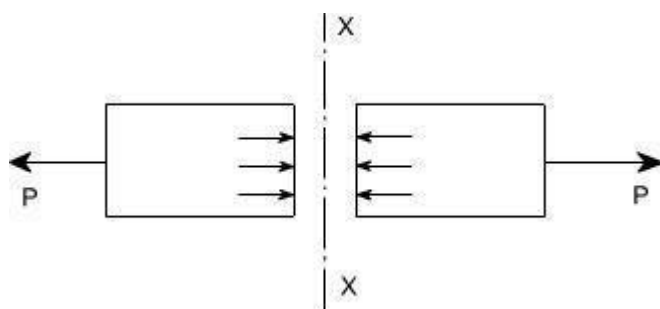

Now stress is defined as the force intensity or force per unit area. Here we use a symbol to represent the stress.

$$\sigma = \frac{P}{A}$$

Where A is the area of the X – section

Here we are using an assumption that the total force or total load carried by the rectangular bar is uniformly distributed over its cross – section.

But the stress distributions may be far from uniform, with local regions of high stress known as stress concentrations.

If the force carried by a component is not uniformly distributed over its cross – sectional area, A, we must consider a small area, 'A' which carries a small load P, of the total force 'P', Then definition of stress is

$$\sigma = \frac{\delta F}{\delta A}$$

As a particular stress generally holds true only at a point, therefore it is defined mathematically as

$$\sigma = \lim_{\delta A \rightarrow 0} \frac{\delta F}{\delta A}$$

Units :

The basic units of stress in S.I units i.e. (International system) are N / m² (or Pa)

$$\text{MPa} = 10^6 \text{ Pa}$$

$$\text{GPa} = 10^9 \text{ Pa}$$

$$\text{KPa} = 10^3 \text{ Pa}$$

Some times N / mm² units are also used, because this is an equivalent to MPa. While US customary unit is pound per square inch psi.

TYPES OF STRESSES :

only two basic stresses exists : (1) normal stress and (2) shear stress. Other stresses either are similar to these basic stresses or are a combination of these e.g. bending stress is a combination tensile, compressive and shear stresses. Torsional stress, as encountered in twisting of a shaft is a shearing stress.

Let us define the normal stresses and shear stresses in the following sections.

Normal stresses : We have defined stress as force per unit area. If the stresses are normal to the areas concerned, then these are termed as normal stresses. The normal stresses are generally denoted by a Greek letter (σ)

This is also known as uniaxial state of stress, because the stresses acts only in one direction however, such a state rarely exists, therefore we have biaxial and triaxial state of stresses where either the two mutually perpendicular normal stresses acts or three mutually perpendicular normal stresses acts as shown in the figures below :

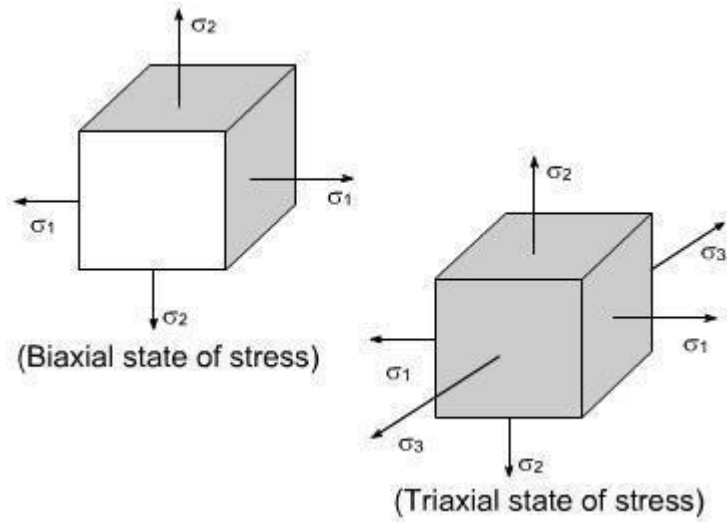

Tensile or compressive stresses :

The normal stresses can be either tensile or compressive whether the stresses acts out of the area or into the area

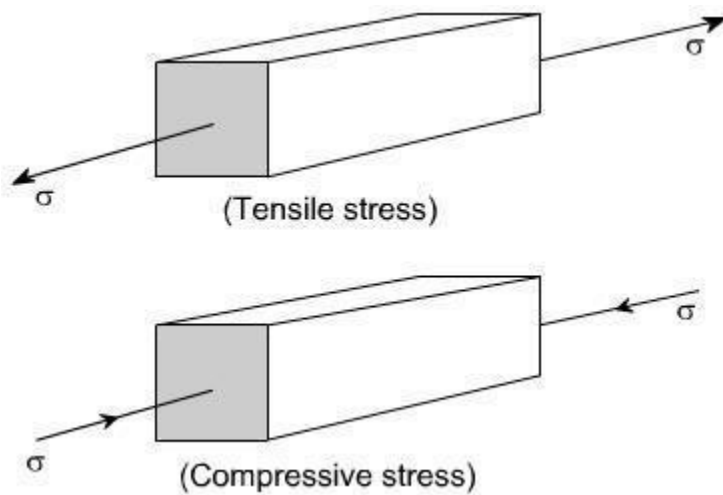

Bearing Stress : When one object presses against another, it is referred to a bearing stress (They are in fact the compressive stresses).

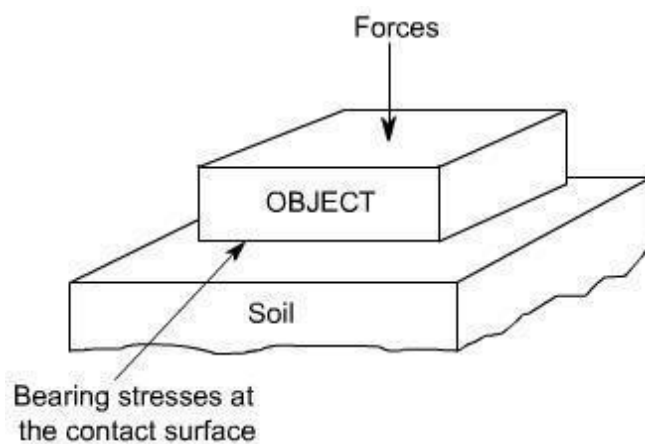

Shear stresses :

Let us consider now the situation, where the cross – sectional area of a block of material is subject to a distribution of forces which are parallel, rather than normal, to the area concerned. Such forces are associated with a shearing of the material, and are referred to as shear forces. The resulting force intensities are known as shear stresses.

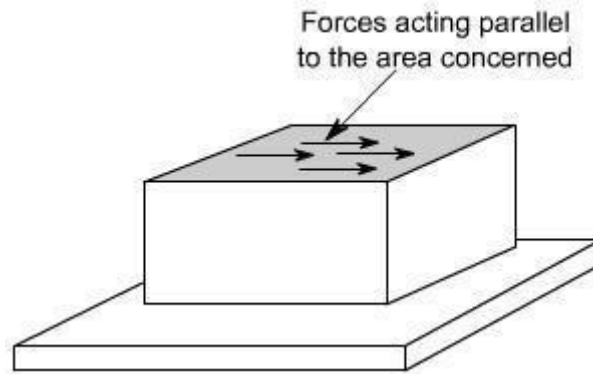

The resulting force intensities are known as shear stresses, the mean shear stress being equal to

$$\tau = \frac{P}{A}$$

Where P is the total force and A the area over which it acts.

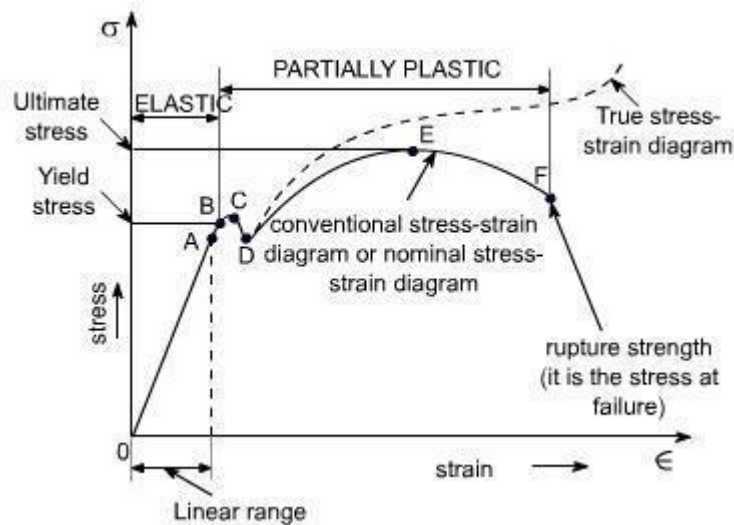

Nominal stress – Strain OR Conventional Stress – Strain diagrams:

Stresses are usually computed on the basis of the original area of the specimen; such stresses are often referred to as conventional or nominal stresses.

True stress – Strain Diagram:

Since when a material is subjected to a uniaxial load, some contraction or expansion always takes place. Thus, dividing the applied force by the corresponding actual area of the specimen at the same instant gives the so called true stress.

SALIENT POINTS OF THE GRAPH:

(A) So it is evident from the graph that the strain is proportional to strain or elongation is proportional to the load giving a st. line relationship. This law of proportionality is valid upto a point A.

Or we can say that point A is some ultimate point when the linear nature of the graph ceases or there is a deviation from the linear nature. This point is known as **the limit of proportionality or the proportionality limit**.

(B) For a short period beyond the point A, the material may still be elastic in the sense that the deformations are completely recovered when the load is removed. The limiting point B is termed as **Elastic Limit**.

(C) and (D) - Beyond the elastic limit plastic deformation occurs and strains are not totally recoverable. There will be thus permanent deformation or permanent set when load is removed. These two points are termed as upper and lower yield points respectively. The stress at the yield point is called the yield strength.

A study a stress – strain diagrams shows that the yield point is so near the proportional limit that for most purpose the two may be taken as one. However, it is much easier to locate the former. For material which do not possess a well define yield points, In order to find the yield point or yield strength, an offset method is applied.

In this method a line is drawn parallel to the straight line portion of initial stress diagram by off setting this by an amount equal to 0.2% of the strain as shown as below and this happens especially for the low carbon steel.

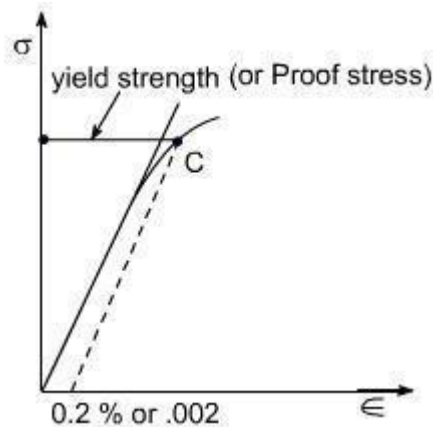

(E) A further increase in the load will cause marked deformation in the whole volume of the metal. The maximum load which the specimen can with stand without failure is called the load at the ultimate strength.

The highest point 'E' of the diagram corresponds to the ultimate strength of a material.

σ_u = Stress which the specimen can with stand without failure & is known as Ultimate Strength or Tensile Strength.

σ_u is equal to load at E divided by the original cross-sectional area of the bar.

(F) Beyond point E, the bar begins to forms neck. The load falling from the maximum until fracture occurs at F.

[Beyond point E, the cross-sectional area of the specimen begins to reduce rapidly over a relatively small length of bar and the bar is said to form a neck. This necking takes place whilst the load reduces, and fracture of the bar finally occurs at point F]

Note: Owing to large reduction in area produced by the necking process the actual stress at fracture is often greater than the above value. Since the designers are interested in maximum loads which can be carried by the complete cross section, hence the stress at fracture is seldom of any practical value.

Percentage Elongation:

The ductility of a material in tension can be characterized by its elongation and by the reduction in area at the cross section where fracture occurs.

It is the ratio of the extension in length of the specimen after fracture to its initial gauge length, expressed in percent.

$$\delta = \frac{(l_1 - l_g)}{l_g} \times 100$$

l_1 = gauge length of specimen after fracture (or the distance between the gage marks at fracture)

l_g = gauge length before fracture (i.e. initial gauge length)

For 50 mm gage length, steel may have a % elongation of the order of 10% to 40%.

Ductile and Brittle Materials:

Based on this behaviour, the materials may be classified as ductile or brittle materials

Ductile Materials:

If we just examine the earlier tension curve one can notice that the extension of the materials over the plastic range is considerably in excess of that associated with elastic loading. The capacity of materials to allow these large deformations or large extensions without failure is termed as ductility. The materials with high ductility are termed as ductile materials.

Brittle Materials:

A brittle material is one which exhibits a relatively small extension or deformation to fracture, so that the partially plastic region of the tensile test graph is much reduced.

This type of graph is shown by the cast iron or steels with high carbon contents or concrete.

ELASTIC CONSTANTS

In considering the elastic behavior of an isotropic materials under, normal, shear and hydrostatic loading, we introduce a total of four elastic constants namely E, G, K, and μ .

It turns out that not all of these are independent to the others. In fact, given any two of them, the other two can be foundout . Let us define these elastic constants

(i) E = Young's Modulus of Rigidity

$$= \text{Stress} / \text{strain}$$

(ii) G = Shear Modulus or Modulus of rigidity

$$= \text{Shear stress} / \text{Shear strain}$$

(iii) μ = Possion's ratio

$$= \text{lateral strain} / \text{longitudinal strain}$$

(iv) K = Bulk Modulus of elasticity

$$= \text{Volumetric stress} / \text{Volumetric strain}$$

Where

Volumetric strain = sum of linear stress in x, y and z

direction. Volumetric stress = stress which cause the change

in volume. Let us find the relations between them

RELATION AMONG ELASTIC CONSTANTS

Relation between E, G and μ :

Let us establish a relation among the elastic constants E,G and . Consider a cube of material of side 'a' subjected to the action of the shear and complementary shear stresses as shown in the figure and producing the strained shape as shown in the figure below.

Assuming that the strains are small and the angle A C B may be taken as 45^0 .

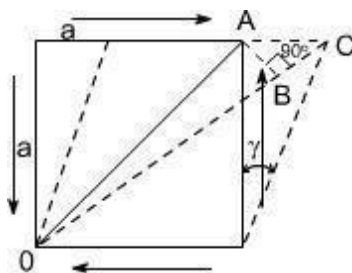

Therefore strain on the diagonal OA

= Change in length / original length

Since angle between OA and OB is very small hence OA OB therefore BC, is the change in the length of the diagonal OA

$$\begin{aligned} \text{Thus, strain on diagonal OA} &= \frac{BC}{OA} \\ &= \frac{AC \cos 45^\circ}{OA} \\ OA &= \frac{a}{\sin 45^\circ} = a\sqrt{2} \\ \text{hence strain} &= \frac{AC}{a\sqrt{2}} \cdot \frac{1}{\sqrt{2}} \\ &= \frac{AC}{2a} \end{aligned}$$

but $AC = a\gamma$

where γ = shear strain

$$\text{Thus, the strain on diagonal} = \frac{a\gamma}{2a} = \frac{\gamma}{2}$$

From the definition

$$G = \frac{\tau}{\gamma} \text{ or } \gamma = \frac{\tau}{G}$$

$$\text{thus, the strain on diagonal} = \frac{\gamma}{2} = \frac{\tau}{2G}$$

Now this shear stress system is equivalent or can be replaced by a system of direct stresses at 45° as shown below. One set will be compressive, the other tensile, and both will be equal in value to the applied shear strain.

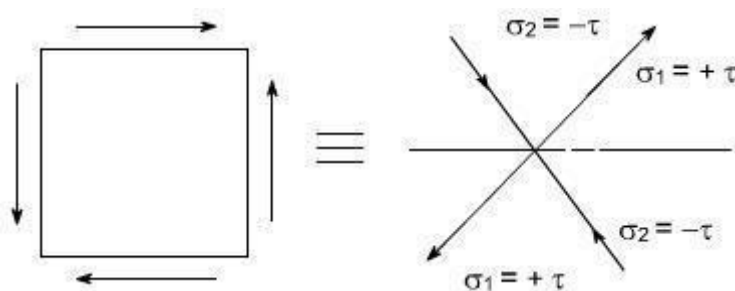

Thus, for the direct state of stress system which applies along the diagonals:

$$\begin{aligned}\text{strain on diagonal} &= \frac{\sigma_1}{E} - \mu \frac{\sigma_2}{E} \\ &= \frac{\tau}{E} - \mu \frac{(-\tau)}{E} \\ &= \frac{\tau}{E}(1 + \mu)\end{aligned}$$

equating the two strains one may get

$$\frac{\tau}{2G} = \frac{\tau}{E}(1 + \mu)$$

or $E = 2G(1 + \mu)$

We have introduced a total of four elastic constants, i.e E, G, K and μ . It turns out that not all of these are independent of the others. Infact given any two of them, the other two can be found.

Again $E = 3K(1 - 2\gamma)$

$$\Rightarrow \frac{E}{3(1 - 2\gamma)} = K$$

if $\gamma = 0.5$ $K = \infty$

$$\epsilon_v = \frac{(1 - 2\gamma)}{E} (\epsilon_x + \epsilon_y + \epsilon_z) = 3 \frac{\sigma}{E} (1 - 2\gamma)$$

(for $\epsilon_x = \epsilon_y = \epsilon_z$ hydrostatic state of stress)

$\epsilon_v = 0$ if $\gamma = 0.5$

irrespective of the stresses i.e, the material is incompressible.

When $\mu = 0.5$ Value of k is infinite, rather than a zero value of E and volumetric strain is zero, or in other words, the material is incompressible.

Relation between E, K and μ :

□

Consider a cube subjected to three equal stresses σ as shown in the figure below



The total strain in one direction or along one edge due to the application of hydrostatic stress or volumetric stress is given as

$$= \frac{\sigma}{E} - \gamma \frac{\sigma}{E} - \gamma \frac{\sigma}{E}$$

$$= \frac{\sigma}{E} (1 - 2\gamma)$$

volumetre strain = 3. linear strain

volumetre strain = $\epsilon_x + \epsilon_y + \epsilon_z$

or thus, $\epsilon_x = \epsilon_y = \epsilon_z$

volumetric strain = $3 \frac{\sigma}{E} (1 - 2\gamma)$

By definition

Bulk Modulus of Elasticity (K) = $\frac{\text{Volumetric stress}(\sigma)}{\text{Volumetric strain}}$

or

Volumetric strain = $\frac{\sigma}{k}$

Equating the two strains we get

$$\frac{\sigma}{k} = 3 \cdot \frac{\sigma}{E} (1 - 2\gamma)$$

$$\boxed{E = 3K(1 - 2\gamma)}$$

Relation between E, G and K :

$$E = \frac{9 GK}{3K + G}$$

Relation between E, K and ν :

From the already derived relations, E can be eliminated

$$E = 2G(1 + \nu)$$

$$E = 3K(1 - 2\nu)$$

Thus, we get

$$3K(1 - 2\nu) = 2G(1 + \nu)$$

therefore

$$\nu = \frac{(3K - 2G)}{2(G + 3K)}$$

or

$$\nu = 0.5(3K - 2G)(G + 3K)$$

Engineering Brief about the elastic constants :

We have introduced a total of four elastic constants i.e E, G, K and ν . It may be seen that not all of these are independent of the others. Infact given any two of them, the other two can be determined.

Futher, it may be noted that

$$E = 3K(1 - 2\nu)$$

or

$$K = \frac{E}{(1 - 2\nu)}$$

if $\nu = 0.5$; $K = \infty$

$$\text{Also } \epsilon_v = \frac{(1 - 2\nu)}{E} (\sigma_x + \sigma_y + \sigma_z)$$

$$= \frac{(1 - 2\nu)}{E} \cdot 3\sigma \text{ (for hydrostatic state of stress i.e } \sigma_x = \sigma_y = \sigma_z = \sigma \text{)}$$

hence if $\nu = 0.5$, the value of K becomes infinite, rather than a zero value of E and the volumetric strain is zero or in otherwords, the material becomes incompressible

Futher, it may be noted that under condition of simple tension and simple shear, all real materials tend to experience displacements in the directions of the applied forces and Under hydrostatic loading they tend to increase in volume. In otherwords the value of the elastic constants E, G and K cannot be negative

Therefore, the relations

$$E = 2 G (1 + \nu)$$

$$E = 3 K (1 - 2\nu)$$

Yields $-1 \leq \nu \leq 0.5$

Determination of Poisson's ratio: Poisson's ratio can be determined easily by simultaneous use of two strain gauges on a test specimen subjected to uniaxial tensile or compressive load. One gage is mounted parallel to the longitudinal axis of the specimen and other is mounted perpendicular to the longitudinal axis as shown below:

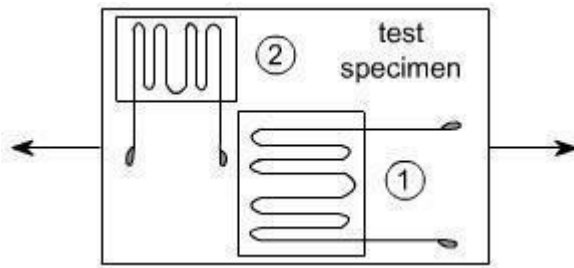

Compression Test: Machines used for compression testing are basically similar to those used for tensile testing often the same machine can be used to perform both tests.

Shape of the specimen: The shape of the machine to be used for the different materials are as follows:

- (i) **For metals and certain plastics:** The specimen may be in the form of a cylinder
- (ii) **For building materials:** Such as concrete or stone the shape of the specimen may be in the form of a cube.

Shape of stress strain diagram

(a) **Ductile materials:** For ductile material such as mild steel, the load Vs compression diagram would be as follows

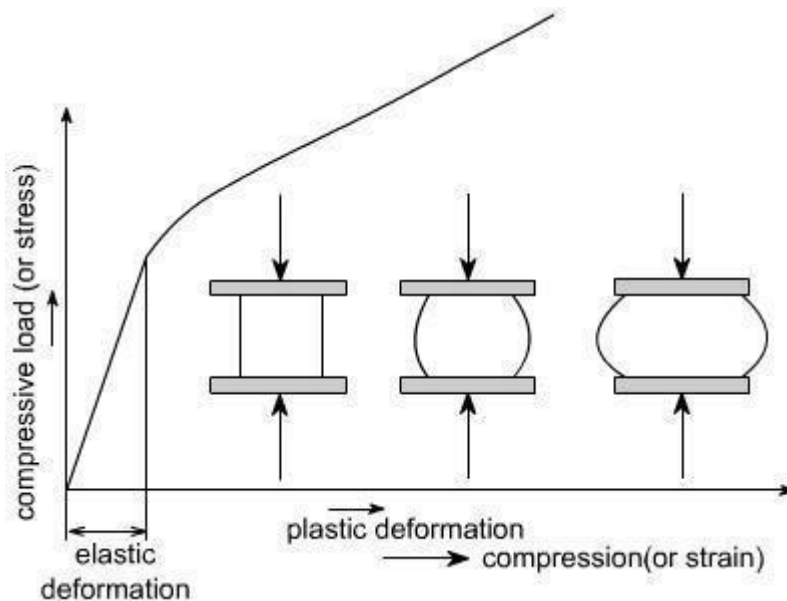

(1) The ductile materials such as steel, Aluminum, and copper have stress – strain diagrams similar to ones which we have for tensile test, there would be an elastic range which is then followed by a plastic region.

(2) The ductile materials (steel, Aluminum, copper) proportional limits in compression test are very much close to those in tension.

(3) In tension test, a specimen is being stretched, necking may occur, and ultimately fracture takes place. On the other hand when a small specimen of the ductile material is compressed, it begins to bulge on sides and becomes barrel shaped as shown in the figure above. With increasing load, the specimen is flattened out, thus offering increased resistance to further shortening (which means that the stress – strains curve goes upward) this effect is indicated in the diagram.

Brittle materials (in compression test)

Brittle materials in compression typically have an initial linear region followed by a region in which the shortening increases at a higher rate than does the load. Thus, the compression stress – strain diagram has a shape that is similar to the shape of the tensile diagram.

However, brittle materials usually reach much higher ultimate stresses in compression than in tension.

For cast iron, the shape may be like this

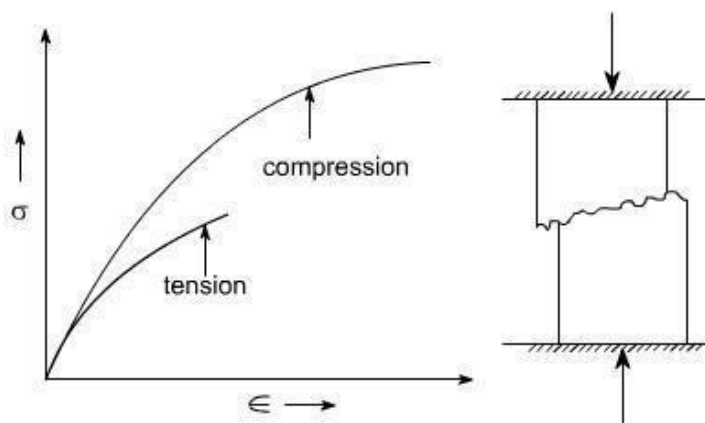

Brittle materials in compression behave elastically up to certain load, and then fail suddenly by splitting or by cracking in the way as shown in figure. The brittle fracture is performed by separation and is not accompanied by noticeable plastic deformation.

Practice Problems:

PROB 1: A standard mild steel tensile test specimen has a diameter of 16 mm and a gauge length of 80 mm such a specimen was tested to destruction, and the following results obtained.

Load at yield point = 87 kN

Extension at yield point = 173×10^{-6} m

Ultimate load = 124 kN

Total extension at fracture = 24 mm

Diameter of specimen at fracture = 9.8 mm

Cross - sectional area at fracture = 75.4 mm^2

Cross - sectional Area 'A' = 200 mm^2

Compute the followings:

- (i) Modulus of elasticity of steel
- (ii) The ultimate tensile stress
- (iii) The yield stress
- (iv) The percentage elongation
- (v) The Percentage reduction in Area.

PROB 2:

A light alloy specimen has a diameter of 16mm and a gauge Length of 80 mm. When tested in tension, the load extension graph proved linear up to a load of 6kN, at which point the extension was 0.034 mm. Determine the limits of proportionality stress and the modulus of elasticity of material.

Note: For a 16mm diameter specimen, the Cross – sectional area $A = 200 \text{ mm}^2$

This is according to tables Determine the limit of proportion stress & the modulus of elasticity for the material.

Ans: 30 MN /m^2 , 70.5 GN /m^2

solution:

$$\begin{aligned}\text{Limit of proportionality stress} &= \frac{6 \text{ kN}}{200 \times 10^{-6}} \\ &= 30 \text{ MN/m}^2\end{aligned}$$

Young Modulus

$$\begin{aligned}E &= \frac{\text{Stress}}{\text{Strain}} \\ \text{strain} &= \frac{.034}{80} \\ E &= 30 \times 10^6 \div \frac{.034}{80} \\ &= 70.5 \text{ GN/m}^2\end{aligned}$$

Strain Energy

Strain Energy of the member is defined as the internal work done in deforming the body by the action of externally applied forces. This energy in elastic bodies is known as **elastic strain energy** :

Strain Energy in uniaxial Loading

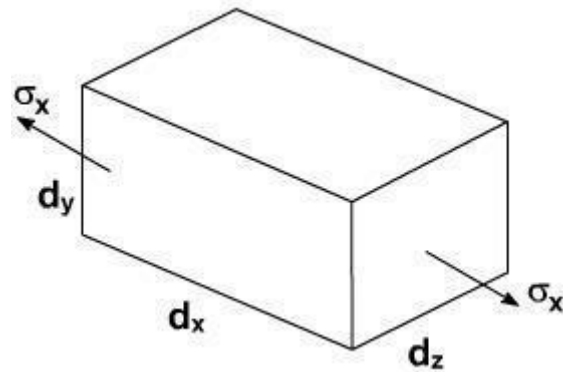

Fig .1

Let us consider an infinitesimal element of dimensions as shown in Fig .1. Let the element be subjected to normal stress σ_x .

The forces acting on the face of this element is $\sigma_x \cdot d_y \cdot d_z$

where

$d_y d_z$ = Area of the element due to the application of forces, the element deforms to an amount = $\sigma_x dx$

$$= \frac{\text{Change in length}}{\text{Original in length}}$$

Assuming the element material to be as linearly elastic the stress is directly proportional to strain as shown in Fig . 2.

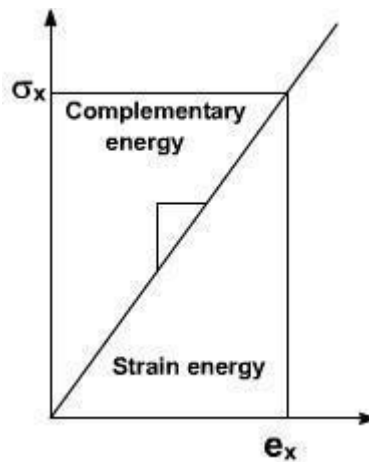

Fig .2

From Fig .2 the force that acts on the element increases linearly from zero until it attains its full value.

For a perfectly elastic body the above work done is the internal strain energy “du”.

$$du = \frac{1}{2} \sigma_x dydz \epsilon_x dx \quad \dots(2)$$

$$= \frac{1}{2} \sigma_x \epsilon_x dx dy dz$$

$$du = \frac{1}{2} \sigma_x \epsilon_x dv \quad \dots\dots(3)$$

where $dv = dx dy dz$

= Volume of the element

By rearranging the above equation we can write

$$U_o = \frac{du}{dv} = \frac{1}{2} \sigma_x \epsilon_x \quad \dots\dots(4)$$

The equation (4) represents the strain energy in elastic body per unit volume of the material its strain energy – density ‘ u_o ’ .

From Hook's Law for elastic bodies, it may be recalled that

$$\sigma = E \epsilon$$

$$U_o = \frac{du}{dv} = \frac{\sigma_x^2}{2E} = \frac{E \epsilon_x^2}{2} \quad \dots\dots(5)$$

$$U = \int_{Vol} \frac{\sigma_x^2}{2E} dv \quad \dots\dots(6)$$

In the case of a rod of uniform cross – section subjected at its ends an equal and opposite forces of magnitude P as shown in the Fig .3.

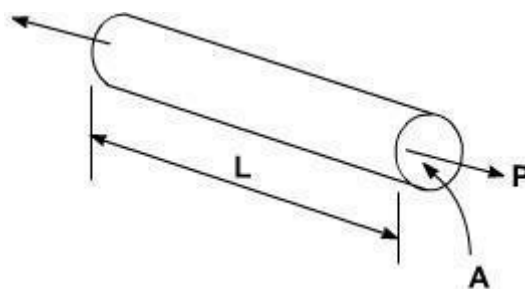

Fig .3

$$U = \int_{vol} \frac{\sigma_x^2}{2E} dv$$

$$U = \int_0^L \frac{P^2}{2EA^2} Adx$$

$$U = \frac{P^2L}{2AE}$$

$$\sigma_x = \frac{P}{A}$$

$dv = Adx = \text{Element volume}$

$A = \text{Area of the bar.}$
 $L = \text{Length of the bar}$

.....(7)

Modulus of resilience :

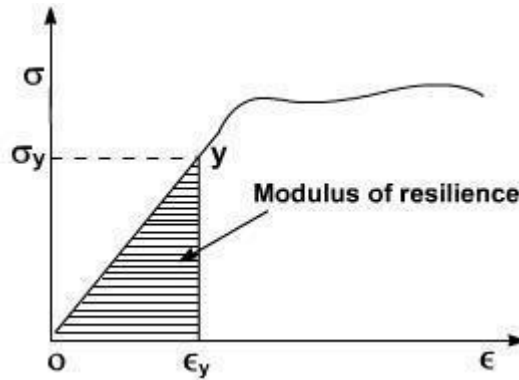

Fig .4

Suppose ' σ_x ' in strain energy equation is put equal to σ_y i.e. the stress at proportional limit or yield point. The resulting strain energy gives an index of the materials ability to store or absorb energy without permanent deformation

So
$$U_y = \frac{\sigma_y^2}{2E}$$
(8)

The quantity resulting from the above equation is called the Modulus of resilience

The modulus of resilience is equal to the area under the straight line portion 'OY' of the stress – strain diagram as shown in Fig .4 and represents the energy per unit volume that the material can absorb without yielding. Hence this is used to differentiate materials for applications where energy must be absorbed by members.

Modulus of Toughness :

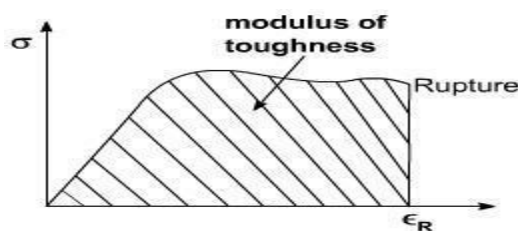

Fig .5

Suppose ' ϵ ' [strain] in strain energy expression is replaced by ϵ_R strain at rupture, the resulting strain energy density is called modulus of toughness

$$U = \int_0^{\epsilon} E \epsilon_x dx = \frac{E \epsilon_R^2}{2} dv$$
$$U = \frac{E \epsilon_R^2}{2} \quad \dots\dots(9)$$

From the stress – strain diagram, the area under the complete curve gives the measure of modulus of toughness. It is the materials.

Ability to absorb energy upto fracture. It is clear that the toughness of a material is related to its ductility as well as to its ultimate strength and that the capacity of a structure to withstand an impact Load depends upon the toughness of the material used.

UNIT-II
SHEAR FORCE AND BENDING MOMENT

Concept of Shear Force and Bending moment in beams:

When the beam is loaded in some arbitrarily manner, the internal forces and moments are developed and the terms shear force and bending moments come into pictures which are helpful to analyze the beams further. Let us define these terms

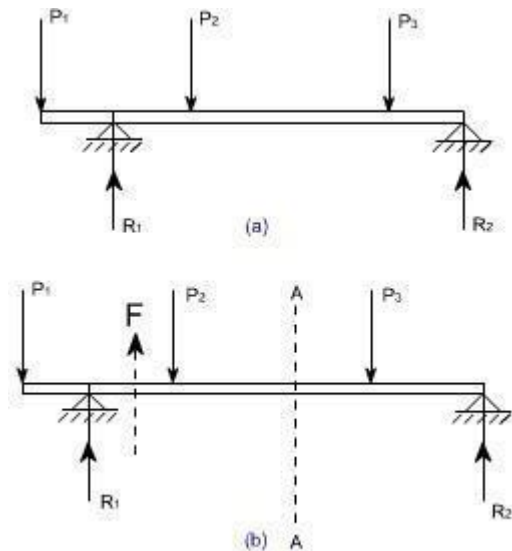

Fig 1

Now let us consider the beam as shown in fig 1(a) which is supporting the loads P_1 , P_2 , P_3 and is simply supported at two points creating the reactions R_1 and R_2 respectively. Now let us assume that the beam is to be divided into or imagined to be cut into two portions at a section AA. Now let us assume that the resultant of loads and reactions to the left of AA is 'F' vertically upwards, and since the entire beam is to remain in equilibrium, thus the resultant of forces to the right of AA must also be F, acting downwards. This force 'F' is as a shear force. The shearing force at any x-section of a beam represents the tendency for the portion of the beam to one side of the section to slide or shear laterally relative to the other portion.

Therefore, now we are in a position to define the shear force 'F' to as follows:

At any x-section of a beam, the shear force 'F' is the algebraic sum of all the lateral components of the forces acting on either side of the x-section.

Sign Convention for Shear Force:

The usual sign conventions to be followed for the shear forces have been illustrated in figures 2 and 3.

Fig 2: Positive Shear Force

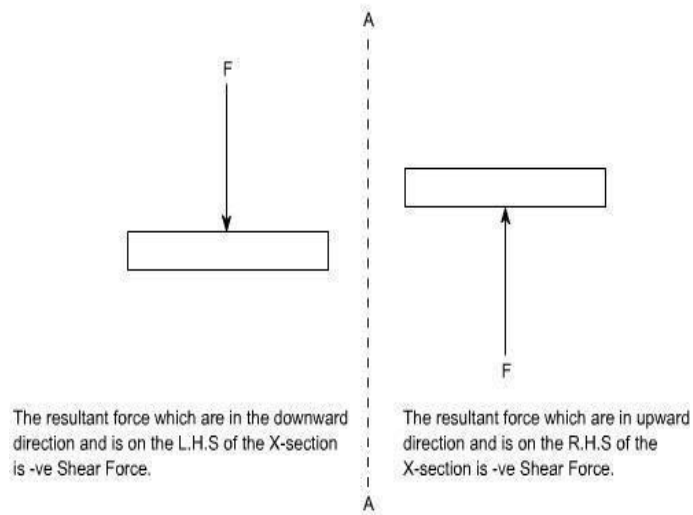
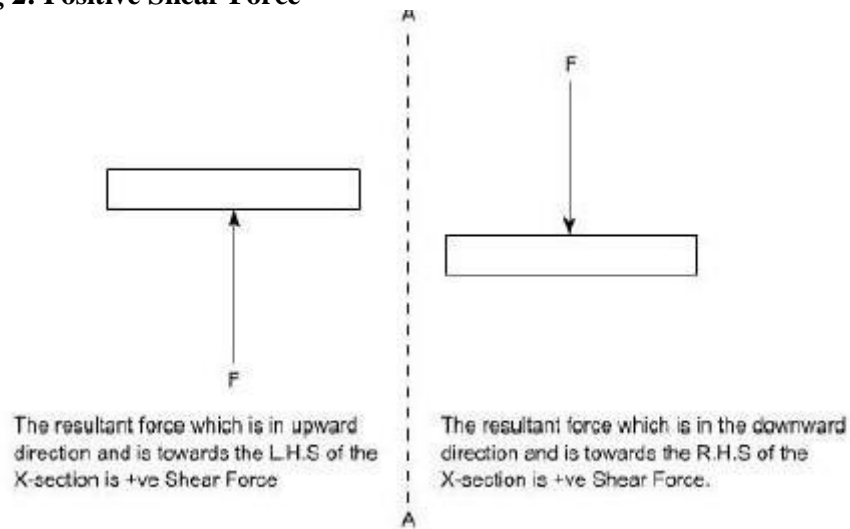

Fig 3: Negative Shear Force

Bending Moment:

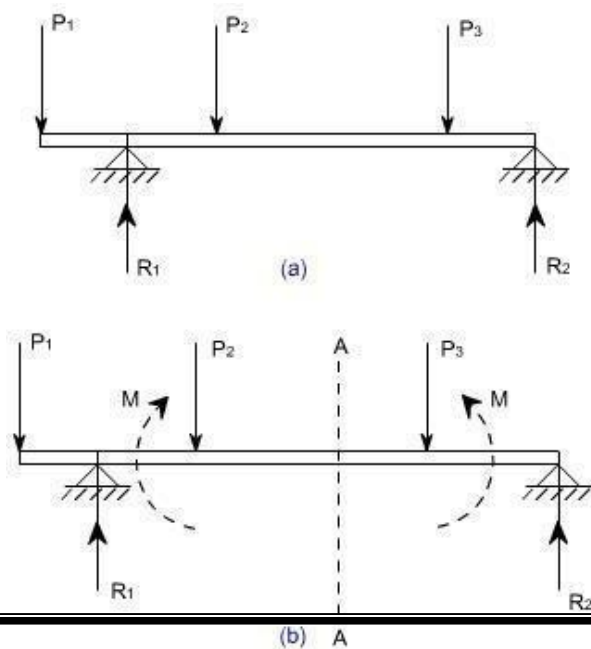

Fig 4

Let us again consider the beam which is simply supported at the two prints, carrying loads P_1 , P_2 and P_3 and having the reactions R_1 and R_2 at the supports Fig 4. Now, let us imagine that the beam is cut into two portions at the x-section AA. In a similar manner, as done for the case of shear force, if we say that the resultant moment about the section AA of all the loads and reactions to the left of the x-section at AA is M in C.W direction, then moment of forces to the right of x-section AA must be ' M ' in C.C.W. Then ' M ' is called as the Bending moment and is abbreviated as B.M. Now one can define the bending moment to be simply as the algebraic sum of the moments about an x-section of all the forces acting on either side of the section

Sign Conventions for the Bending Moment:

For the bending moment, following sign conventions may be adopted as indicated in Fig 5 and Fig 6.

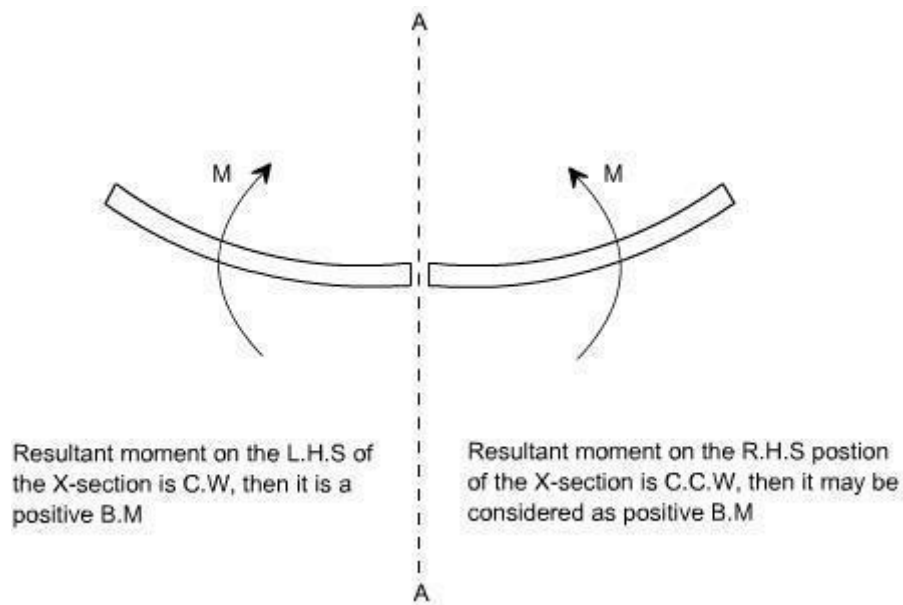

Fig 5: Positive Bending Moment

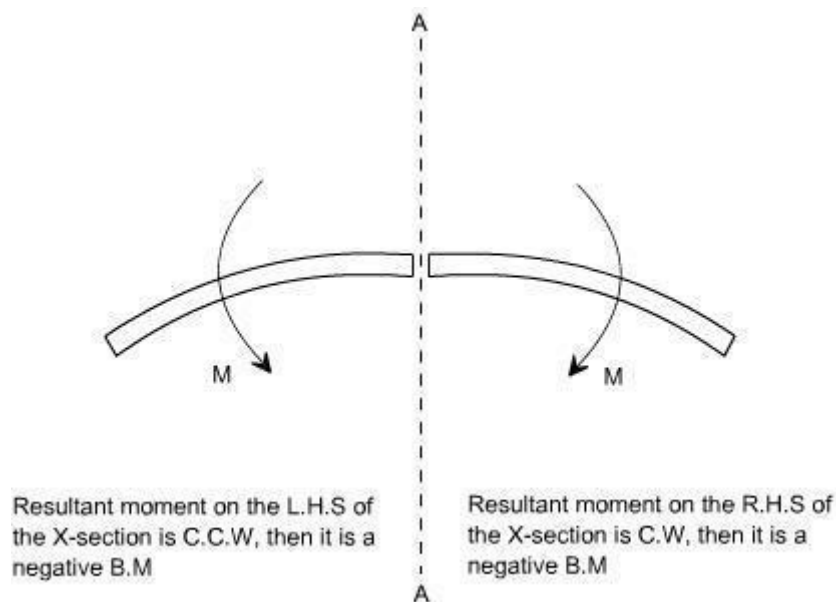

Fig 6: Negative Bending Moment

Some times, the terms 'Sagging' and Hogging are generally used for the positive and negative bending moments respectively.

Bending Moment and Shear Force Diagrams:

The diagrams which illustrate the variations in B.M and S.F values along the length of the beam for any fixed loading conditions would be helpful to analyze the beam further.

Thus, a shear force diagram is a graphical plot, which depicts how the internal shear force 'F' varies along the length of beam. If x denotes the length of the beam, then F is function x i.e. $F(x)$.

Similarly a bending moment diagram is a graphical plot which depicts how the internal bending moment 'M' varies along the length of the beam. Again M is a function x i.e. $M(x)$.

Basic Relationship Between The Rate of Loading, Shear Force and Bending Moment:

The construction of the shear force diagram and bending moment diagrams is greatly simplified if the relationship among load, shear force and bending moment is established.

Let us consider a simply supported beam AB carrying a uniformly distributed load w /length. Let us imagine to cut a short slice of length dx cut out from this loaded beam at distance ' x ' from the origin 'O'.

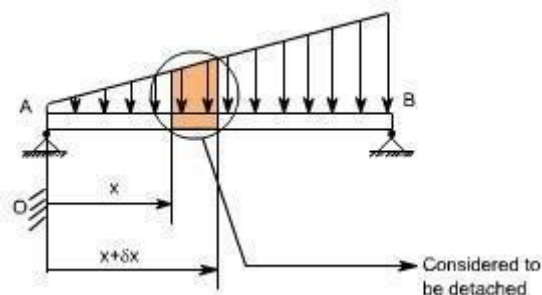

Let us detach this portion of the beam and draw its free body diagram.

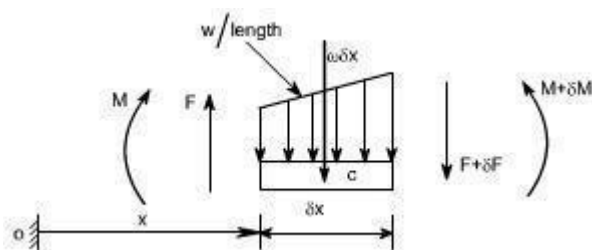

The forces acting on the free body diagram of the detached portion of this loaded beam are the following

- The shearing force F and $F + \delta F$ at the section x and $x + \delta x$ respectively.
- The bending moment at the sections x and $x + \delta x$ be M and $M + \delta M$ respectively.
- Force due to external loading, if 'w' is the mean rate of loading per unit length then the total loading on this slice of length δx is $w \cdot \delta x$, which is approximately acting through the centre 'c'. If the loading is assumed to be uniformly distributed then it would pass exactly through the centre 'c'.

This small element must be in equilibrium under the action of these forces and couples.

Now let us take the moments at the point 'c'. Such that

$$\begin{aligned}
 M + F \cdot \frac{\delta x}{2} + (F + \delta F) \cdot \frac{\delta x}{2} &= M + \delta M \\
 \Rightarrow F \cdot \frac{\delta x}{2} + (F + \delta F) \cdot \frac{\delta x}{2} &= \delta M \\
 \Rightarrow F \cdot \frac{\delta x}{2} + F \cdot \frac{\delta x}{2} + \delta F \cdot \frac{\delta x}{2} &= \delta M \quad [\text{Neglecting the product of} \\
 &\quad \delta F \text{ and } \delta x \text{ being small quantities}] \\
 \Rightarrow F \cdot \delta x &= \delta M \\
 \Rightarrow F &= \frac{\delta M}{\delta x}
 \end{aligned}$$

Under the limits $\delta x \rightarrow 0$

$$\boxed{F = \frac{dM}{dx}} \quad \dots\dots\dots (1)$$

Re solving the forces vertically we get

$$\begin{aligned}
 w \cdot \delta x + (F + \delta F) &= F \\
 \Rightarrow w &= -\frac{\delta F}{\delta x} \\
 \text{Under the limits } \delta x &\rightarrow 0
 \end{aligned}$$

$$\Rightarrow w = -\frac{dF}{dx} \text{ or } -\frac{d}{dx} \left(\frac{dM}{dx} \right)$$

$$\boxed{w = -\frac{dF}{dx} = -\frac{d^2M}{dx^2}} \quad \dots\dots\dots (2)$$

Conclusions: From the above relations, the following important conclusions may be drawn

- From Equation (1), the area of the shear force diagram between any two points, from the basic calculus is the bending moment diagram

$$M = \int F \cdot dx$$

- The slope of bending moment diagram is the shear force, thus

$$F = \frac{dM}{dx}$$

Thus, if $F=0$; the slope of the bending moment diagram is zero and the bending moment is therefore constant.'

- The maximum or minimum Bending moment occurs where $\frac{dM}{dx} = 0$.

The slope of the shear force diagram is equal to the magnitude of the intensity of the distributed loading at any position along the beam. The -ve sign is as a consequence of our particular choice of sign conventions

Procedure for drawing shear force and bending moment diagram:

Preamble:

The advantage of plotting a variation of shear force F and bending moment M in a beam as a function of 'x' measured from one end of the beam is that it becomes easier to determine the maximum absolute value of shear force and bending moment.

Further, the determination of value of M as a function of 'x' becomes of paramount importance so as to determine the value of deflection of beam subjected to a given loading.

Construction of shear force and bending moment diagrams:

A shear force diagram can be constructed from the loading diagram of the beam. In order to draw this, first the reactions must be determined always. Then the vertical components of forces and reactions are successively summed from the left end of the beam to preserve the mathematical sign conventions adopted. The shear at a section is simply equal to the sum of all the vertical forces to the left of the section.

When the successive summation process is used, the shear force diagram should end up with the previously calculated shear (reaction at right end of the beam. No shear force acts through the beam just beyond the last vertical force or reaction. If the shear force diagram closes in this fashion, then it gives an important check on mathematical calculations.

The bending moment diagram is obtained by proceeding continuously along the length of beam from the left hand end and summing up the areas of shear force diagrams giving due regard to sign. The process of obtaining the moment diagram from the shear force diagram by summation is exactly the same as that for drawing shear force diagram from load diagram.

It may also be observed that a constant shear force produces a uniform change in the bending moment, resulting in straight line in the moment diagram. If no shear force exists along a certain portion of a beam, then it indicates that there is no change in moment takes place. It may also further observe that $dm/dx = F$ therefore, from the fundamental theorem of calculus the maximum or minimum moment occurs where the shear is zero. In order to check the validity of the bending moment diagram, the terminal conditions for the moment must be satisfied. If the end is free or pinned, the computed sum must be equal to zero. If the end is built in, the moment computed by the summation must be equal to the one calculated initially for the reaction. These conditions must always be satisfied.

Illustrative problems:

In the following sections some illustrative problems have been discussed so as to illustrate the procedure for drawing the shear force and bending moment diagrams

1. A cantilever of length carries a concentrated load 'W' at its free end.

Draw shear force and bending moment.

Solution:

At a section a distance x from free end consider the forces to the left, then $F = -W$ (for all values of x) -ve sign means the shear force to the left of the x -section are in downward direction and therefore negative

Taking moments about the section gives (obviously to the left of the section)

$M = -Wx$ (-ve sign means that the moment on the left hand side of the portion is in the anticlockwise direction and is therefore taken as -ve according to the sign convention)

so that the maximum bending moment occurs at the fixed end i.e. $M = -Wl$

From equilibrium consideration, the fixing moment applied at the fixed end is Wl and the reaction is W . the shear force and bending moment are shown as,

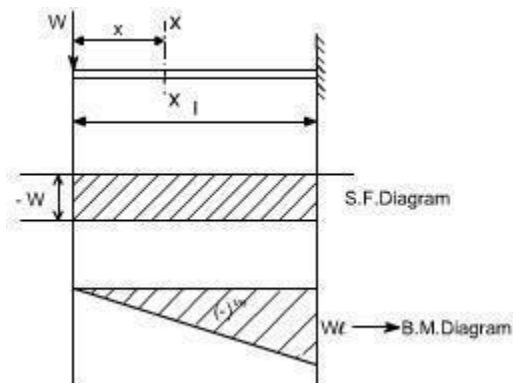

2. Simply supported beam subjected to a central load (i.e. load acting at the mid-way)

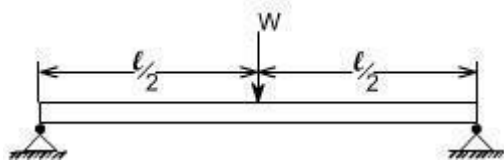

By symmetry the reactions at the two supports would be $W/2$ and $W/2$. now consider any section $X-X$ from the left end then, the beam is under the action of following forces.

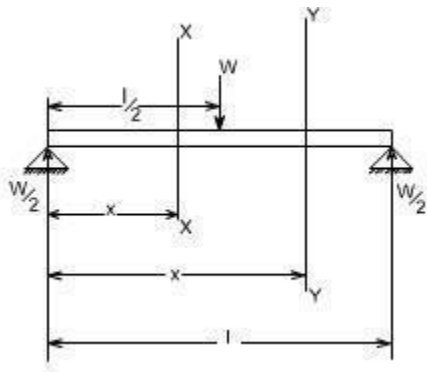

So the shear force at any X-section would be = $W/2$ [Which is constant upto $x < l/2$]

If we consider another section Y-Y which is beyond $l/2$ then

$$S.F_{Y-Y} = \frac{W}{2} - W = \frac{-W}{2} \text{ for all values greater } = l/2$$

Hence S.F diagram can be plotted as,

.For B.M diagram:

If we just take the moments to the left of the cross-section,

$$B.M_{x-x} = \frac{W}{2} x \text{ for } x \text{ lies between } 0 \text{ and } l/2$$

$$B.M_{\text{at } x = l/2} = \frac{W}{2} \cdot \frac{l}{2} \text{ i.e. B.M. at } x = 0$$

$$= \frac{Wl}{4}$$

$$B.M_{Y-Y} = \frac{W}{2} x - W \left(x - \frac{l}{2} \right)$$

Again

$$= \frac{W}{2} x - Wx + \frac{Wl}{2}$$

$$= -\frac{W}{2} x + \frac{Wl}{2}$$

$$B.M_{\text{at } x = l} = -\frac{Wl}{2} + \frac{Wl}{2}$$

$$= 0$$

Which when plotted will give a straight relation i.e.

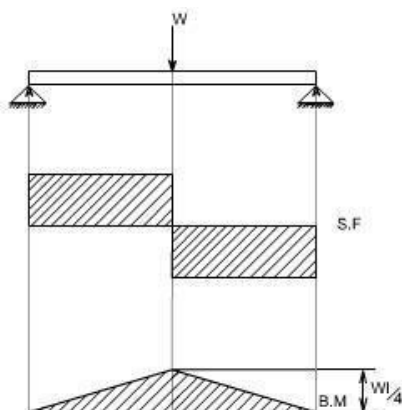

It may be observed that at the point of application of load there is an abrupt change in the shear force, at this point the B.M is maximum.

3. A cantilever beam subjected to U.d.L, draw S.F and B.M diagram.

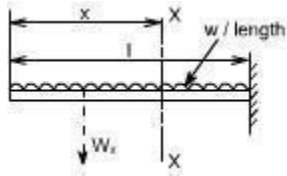

Here the cantilever beam is subjected to a uniformly distributed load whose intensity is given w / length .

Consider any cross-section XX which is at a distance of x from the free end. If we just take the resultant of all the forces on the left of the X-section, then

$$S.F_{XX} = -Wx \text{ for all values of 'x'. ----- (1)}$$

$$S.F_{XX} = 0$$

$$S.F_{XX} \text{ at } x=l = -Wl$$

So if we just plot the equation No. (1), then it will give a straight line relation. Bending Moment at X-X is obtained by treating the load to the left of X-X as a concentrated load of the same value acting through the centre of gravity.

Therefore, the bending moment at any cross-section X-X is

$$\begin{aligned} B.M_{X-X} &= - Wx \frac{x}{2} \\ &= - W \frac{x^2}{2} \end{aligned}$$

The above equation is a quadratic in x , when B.M is plotted against x this will produce a parabolic variation.

The extreme values of this would be at $x = 0$ and $x = l$

$$\begin{aligned} B.M_{\text{at } x=l} &= - \frac{Wl^2}{2} \\ &= \frac{Wl}{2} - Wx \end{aligned}$$

Hence S.F and B.M diagram can be plotted as follows:

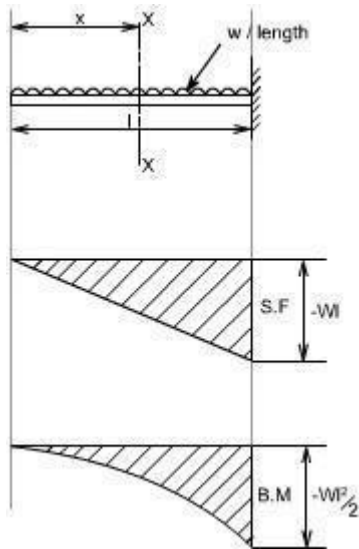

4. Simply supported beam subjected to a uniformly distributed load [U.D.L].

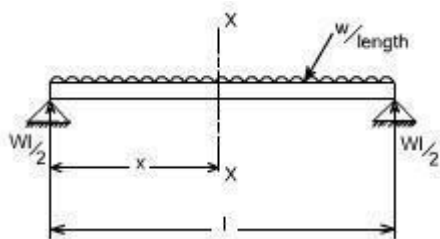

The total load carried by the span would be

= intensity of loading x length

= $w \times l$

By symmetry the reactions at the end supports are each $wl/2$

If x is the distance of the section considered from the left hand end of the beam.

S.F at any X-section X-X is

$$= \frac{wl}{2} - wx$$

$$= w \left(\frac{l}{2} - x \right)$$

Giving a straight relation, having a slope equal to the rate of loading or intensity of the loading.

$$\text{S.F. at } x=0 = \frac{wl}{2} - wx$$

so at

S.F. at $x = \frac{l}{2} = 0$ hence the S.F. is zero at the centre

$$\text{S.F. at } x=l = -\frac{wl}{2}$$

The bending moment at the section x is found by treating the distributed load as acting at its centre of gravity, which is at a distance of $x/2$ from the section

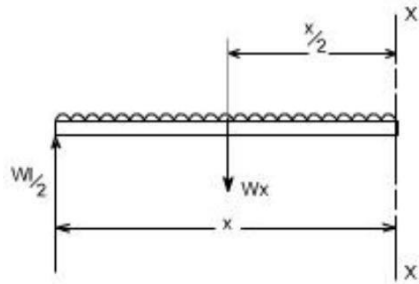

$$\text{B.M.}_{x,x} = \frac{Wl}{2}x - Wx \cdot \frac{x}{2}$$

so the

$$= W \cdot \frac{x}{2}(l - x) \dots\dots(2)$$

$$\text{B.M.}_{\text{at } x=0} = 0$$

$$\text{B.M.}_{\text{at } x=l} = 0$$

$$\text{B.M.}_{\text{at } x=l} = -\frac{Wl^2}{8}$$

So the equation (2) when plotted against x gives rise to a parabolic curve and the shear force and bending moment can be drawn in the following way will appear as follows:

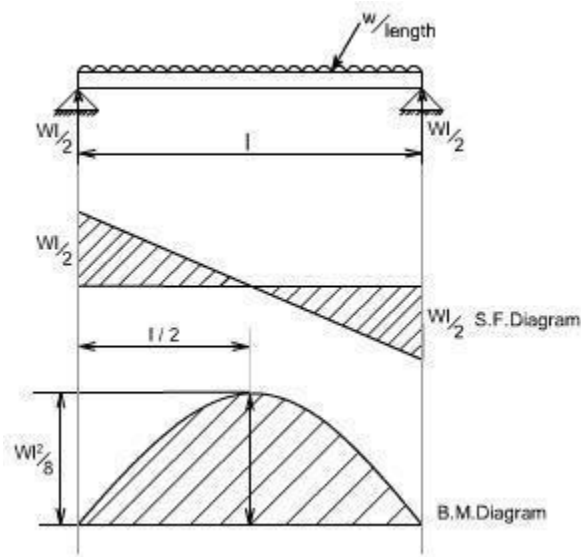

5. Couple.

When the beam is subjected to couple, the shear force and Bending moment diagrams may be drawn exactly in the same fashion as discussed earlier.

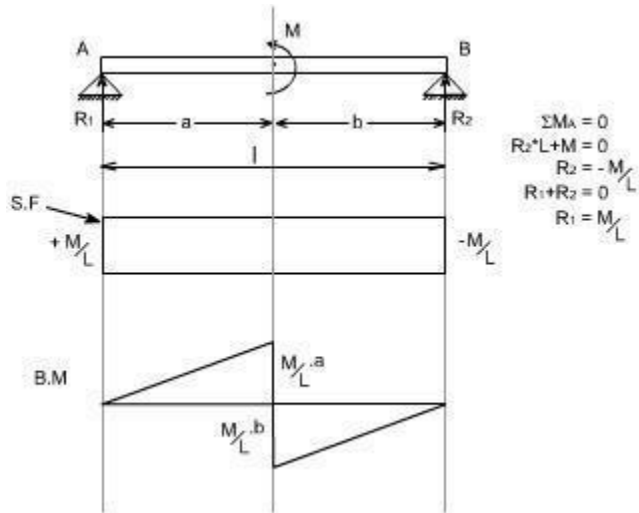

6. Eccentric loads.

When the beam is subjected to an eccentric load, the eccentric load are to be changed into a couple/ force as the case may be, In the illustrative example given below, the 20 kN load acting at a distance of 0.2m may be converted to an equivalent of 20 kN force and a couple of 2 kN.m. similarly a 10 kN force which is acting at an angle of 30° may be resolved into horizontal and vertical components. The rest of the procedure for drawing the shear force and Bending moment remains the same.

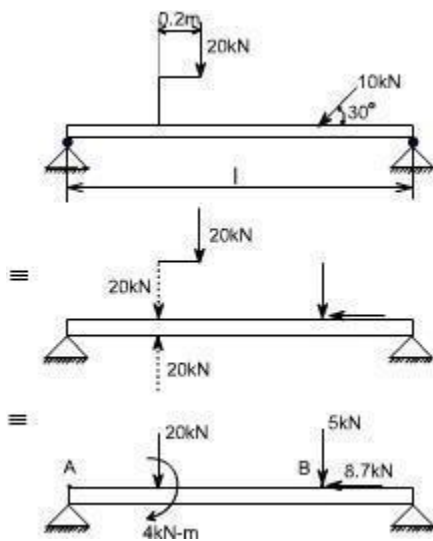

6. Loading changes or there is an abrupt change of loading:

When there is an abrupt change of loading or loads changes, the problem may be tackled in a systematic way. Consider a cantilever beam of 3 meters length. It carries a uniformly distributed load of 2 kN/m and a concentrated loads of 2kN at the free end and 4kN at 2 meters from fixed end. The shearing force and bending moment diagrams are required to be drawn and state the maximum values of the shearing force and bending moment.

Solution

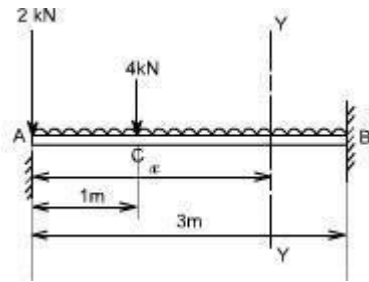

Consider any cross section x-x, at a distance x from the free end

$$\text{Shear Force at } x-x = -2 - 2x \quad 0 < x < 1$$

$$\text{S.F at } x = 0 \text{ i.e. at A} = -2 \text{ kN}$$

$$\text{S.F at } x = 1 = -2 - 2 = -4 \text{ kN}$$

$$\text{S.F at C (} x = 1) = -2 - 2x - 4 \text{ Concentrated load}$$

$$= -2 - 4 - 2 \times 1 \text{ kN}$$

$$= -8 \text{ kN}$$

Again consider any cross-section Y-Y, located at a distance x from the free end

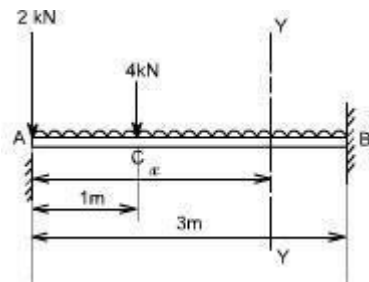

$$\text{S.F at Y-Y} = -2 - 2x - 4 \quad 1 < x < 3$$

This equation again gives S.F at point C equal to -8kN

$$\text{S.F at } x = 3 \text{ m} = -2 - 4 - 2 \times 3$$

$$= -12 \text{ kN}$$

Hence the shear force diagram can be drawn as below:

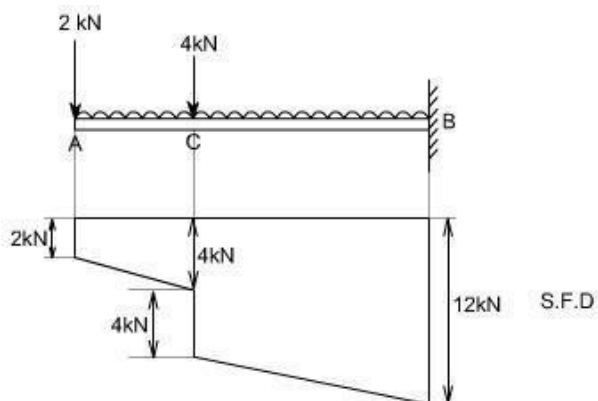

For bending moment diagrams – Again write down the equations for the respective cross sections, as consider above

Bending Moment at $xx = -2x - 2x \cdot x/2$ valid upto AC

B.M at $x = 0 = 0$

B.M at $x = 1\text{m} = -3 \text{ kN}\cdot\text{m}$

For the portion CB, the bending moment equation can be written for the x-section at Y-Y .

B.M at YY = $-2x - 2x \cdot x/2 - 4(x - 1)$

This equation again gives,

B.M at point C = $- 2 \cdot 1 - 1 - 0$ i.e. at $x = 1$

= $-3 \text{ kN}\cdot\text{m}$

at point B i.e. at $x = 3 \text{ m}$

= $- 6 - 9 - 8$

= $- 23 \text{ kN}\cdot\text{m}$

The variation of the bending moment diagrams would obviously be a parabolic

curve Hence the bending moment diagram would be

Point of Contraflexure:

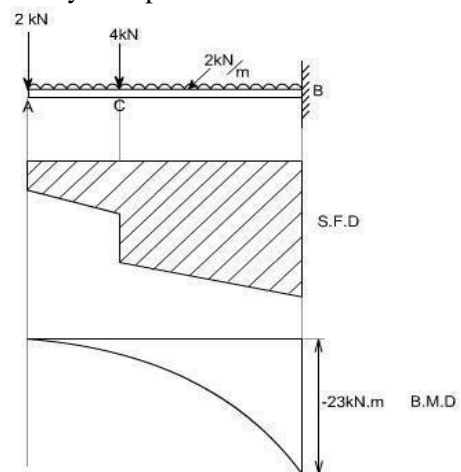
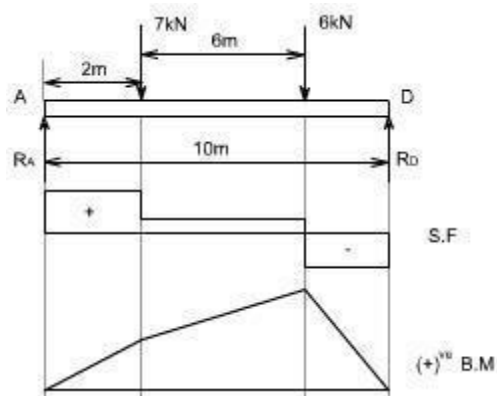

Consider the loaded beam a shown below along with the shear force and Bending moment diagrams for It may be observed that this case, the bending moment diagram is completely positive so that the curvature of the beam varies along its length, but it is always concave upwards or sagging. However if we consider a again a loaded beam as shown below along with the S.F and B.M diagrams, then

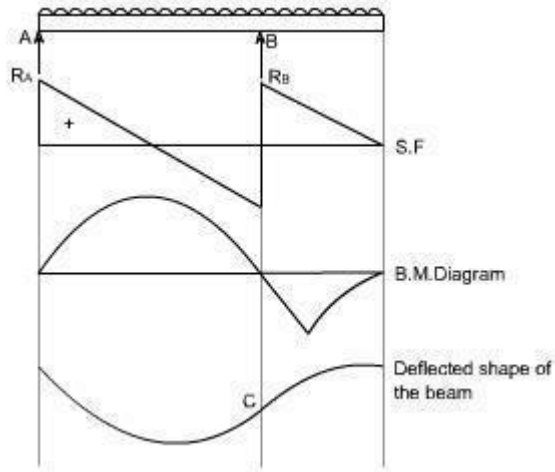

It may be noticed that for the beam loaded as in this case,

The bending moment diagram is partly positive and partly negative. If we plot the deflected shape of the beam just below the bending moment

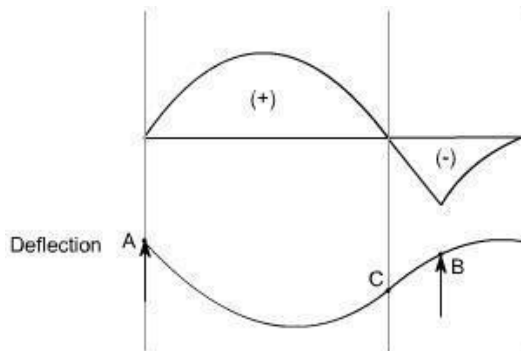

This diagram shows that L.H.S of the beam 'sags' while the R.H.S of the beam 'hogs'

The point C on the beam where the curvature changes from sagging to hogging is a point of contraflexure.

UNIT-III
FLEXURAL STRESSES

Members Subjected to Flexural Loads

Introduction:

In many engineering structures members are required to resist forces that are applied laterally or transversely to their axes. These type of members are termed as beam.

There are various ways to define the beams such as

Definition I: A beam is a laterally loaded member, whose cross-sectional dimensions are small as compared to its length.

Definition II: A beam is nothing simply a bar which is subjected to forces or couples that lie in a plane containing the longitudinal axis of the bar. The forces are understood to act perpendicular to the longitudinal axis of the bar.

Definition III: A bar working under bending is generally termed as a beam.

Materials for Beam:

The beams may be made from several usable engineering materials such commonly among them are as follows:

- Metal
- Wood
- Concrete
- Plastic

Examples of Beams:

Refer to the figures shown below that illustrates the beam

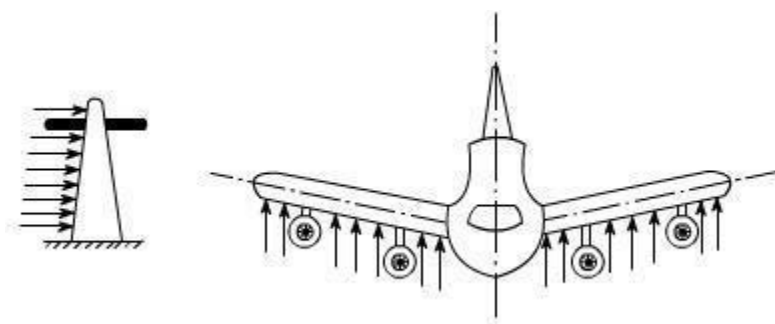

Fig 1

Fig 2

In the fig.1, an electric pole has been shown which is subject to forces occurring due to wind; hence it is an example of beam.

In the fig.2, the wings of an aeroplane may be regarded as a beam because here the aerodynamic action is responsible to provide lateral loading on the member.

Geometric forms of Beams:

The Area of X-section of the beam may take several forms some of them have been shown below:

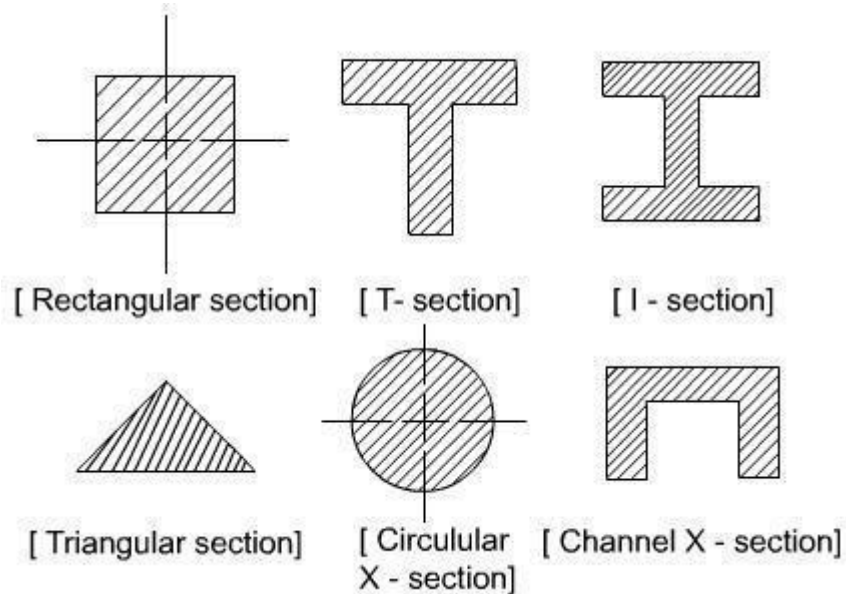

Issues Regarding Beam:

Designer would be interested to know the answers to following issues while dealing with beams in practical engineering application

- At what load will it fail
- How much deflection occurs under the application of loads.

Classification of Beams:

Beams are classified on the basis of their geometry and the manner in which they are supported.

Classification I: The classification based on the basis of geometry normally includes features such as the shape of the X-section and whether the beam is straight or curved.

Classification II: Beams are classified into several groups, depending primarily on the kind of supports used. But it must be clearly understood why do we need supports. The supports are required to provide constraint to the movement of the beams or simply the supports resist the movements either in particular direction or in rotational direction or both. As a consequence of this, the reaction comes into picture whereas to resist rotational movements the moment comes into picture. On the basis of the support, the beams may be classified as follows:

Cantilever Beam: A beam which is supported on the fixed support is termed as a cantilever beam: Now let us understand the meaning of a fixed support. Such a support is obtained by building a beam into a brick wall, casting it into concrete or welding the end of the beam. Such a support provides both the translational and rotational constraint to the beam, therefore the reaction as well as the moments appears, as shown in the figure below

Simply Supported Beam: The beams are said to be simply supported if their supports creates only the translational constraints.

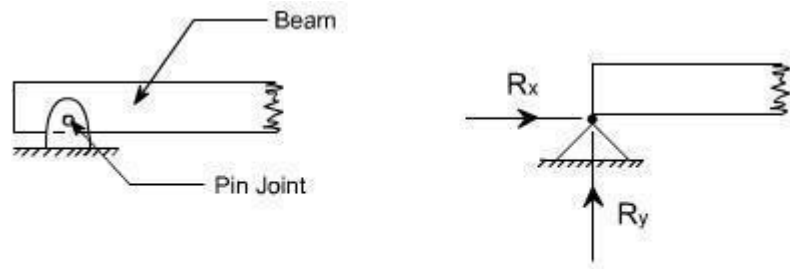

(a) Actual Representation

(b) Diagrammatic Representation

Some times the translational movement may be allowed in one direction with the help of rollers and can be represented like this

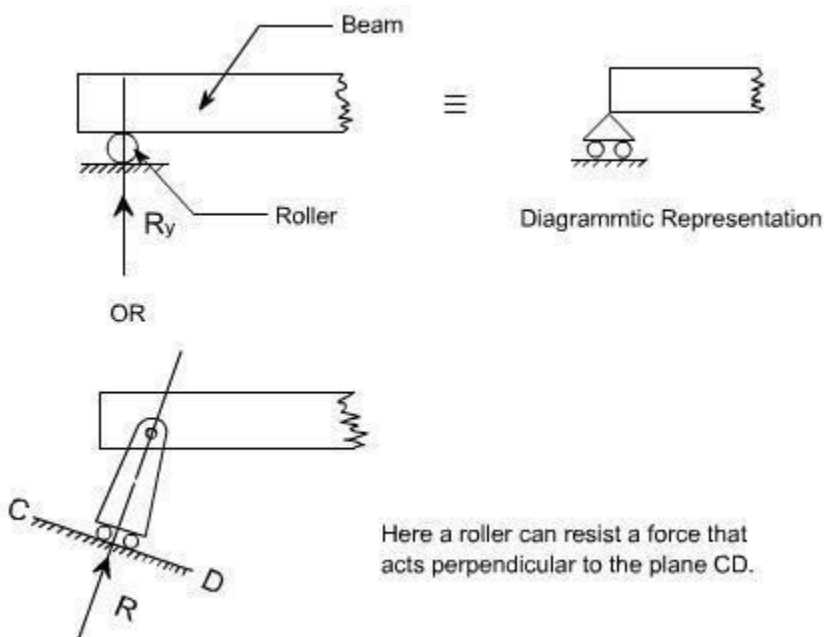

Statically Determinate or Statically Indeterminate Beams:

The beams can also be categorized as statically determinate or else it can be referred as statically indeterminate. If all the external forces and moments acting on it can be determined from the equilibrium conditions alone then. It would be referred as a statically determinate beam, whereas in the statically indeterminate beams one has to consider deformation i.e. deflections to solve the problem.

Types of loads acting on beams:

A beam is normally horizontal where as the external loads acting on the beams is generally in the vertical directions. In order to study the behaviors of beams under flexural loads. It becomes pertinent that one must be familiar with the various types of loads acting on the beams as well as their physical manifestations.

A. Concentrated Load: It is a kind of load which is considered to act at a point. By this we mean that the length of beam over which the force acts is so small in comparison to its total length that one can model the force as though applied at a point in two dimensional view of beam. Here in this case, force or load may be made to act on a beam by a hanger or through other means

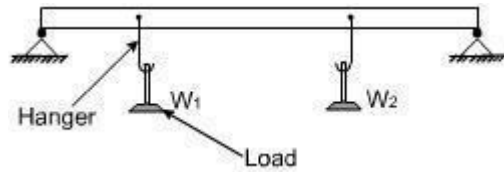

B. Distributed Load: The distributed load is a kind of load which is made to spread over a entire span of beam or over a particular portion of the beam in some specific manner

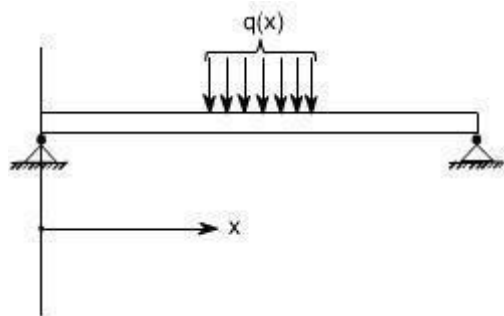

In the above figure, the rate of loading 'q' is a function of x i.e. span of the beam, hence this is a non uniformly distributed load.

The rate of loading 'q' over the length of the beam may be uniform over the entire span of beam, then we call this as a uniformly distributed load (U.D.L). The U.D.L may be represented in either of the way on the beams

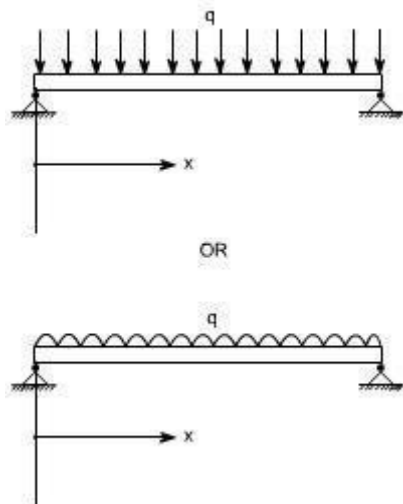

some times the load acting on the beams may be the uniformly varying as in the case of dams or on inclind wall of a vessel containing liquid, then this may be represented on the beam as below:

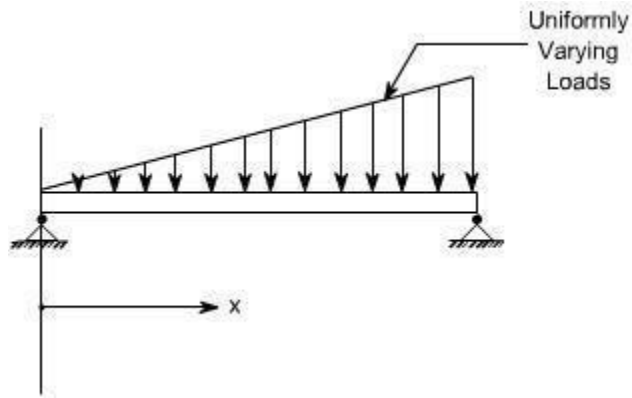

The U.D.L can be easily realized by making idealization of the ware house load, where the bags of grains are placed over a beam.

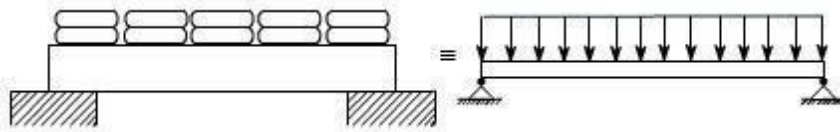

Concentrated Moment:

The beam may be subjected to a concentrated moment essentially at a point. One of the possible arrangement for applying the moment is being shown in the figure below:

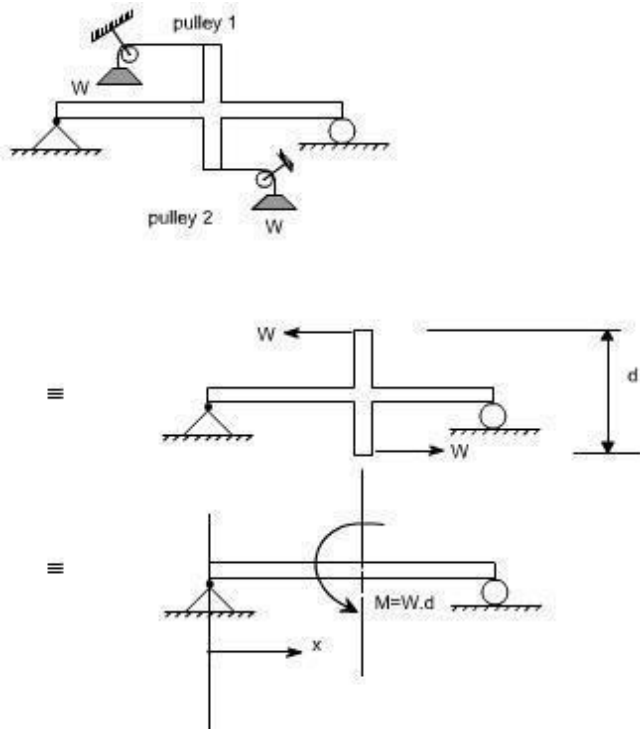

Simple Bending Theory OR Theory of Flexure for Initially Straight Beams

(The normal stress due to bending are called flexure stresses)

Preamble:

When a beam having an arbitrary cross section is subjected to a transverse loads the beam will bend. In addition to bending the other effects such as twisting and buckling may occur, and to investigate a problem that includes all the combined effects of bending, twisting and buckling could become a complicated one. Thus we are interested to investigate the bending effects alone, in order to do so, we have to put certain constraints on the geometry of the beam and the manner of loading.

Assumptions:

The constraints put on the geometry would form the **assumptions**:

1. Beam is initially **straight** , and has a **constant cross-section**.
2. Beam is made of **homogeneous material** and the beam has a **longitudinal plane of symmetry**.
3. Resultant of the applied loads lies in the plane of symmetry.
4. The geometry of the overall member is such that bending not buckling is the primary cause of failure.
5. Elastic limit is nowhere exceeded and '**E**' is same in tension and compression.
6. Plane cross - sections remains plane before and after bending.

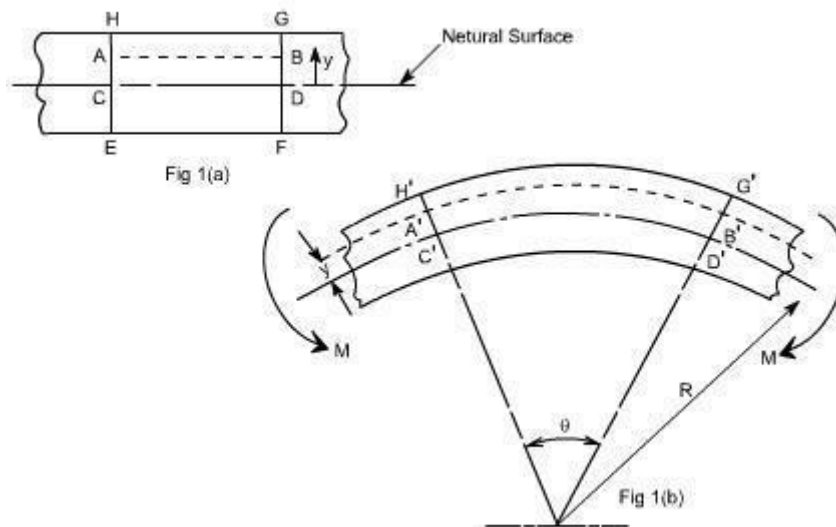

Let us consider a beam initially unstressed as shown in fig 1(a). Now the beam is subjected to a constant bending moment (i.e. 'Zero Shearing Force') along its length as would be obtained by applying equal couples at each end. The beam will bend to the radius R as shown in Fig 1(b)

As a result of this bending, the top fibers of the beam will be subjected to tension and the bottom to compression it is reasonable to suppose, therefore, **that some where between the two there are points at which the stress is zero. The locus of all such points is known as neutral axis** . The radius of curvature R is then measured to this axis. For symmetrical sections the N. A. is the axis of symmetry but what ever the section N. A. will always pass through the centre of the area or centroid.

The above restrictions have been taken so as to eliminate the possibility of 'twisting' of the beam.

Concept of pure bending:

Loading restrictions:

As we are aware of the fact internal reactions developed on any cross-section of a beam may consists of a resultant normal force, a resultant shear force and a resultant couple. In order to ensure that the bending effects alone are investigated, we shall put a constraint on the loading such that the resultant normal and the resultant shear forces are zero on any cross-section perpendicular to the longitudinal axis of the member,

That means $F = 0$

since $\frac{dM}{dX} = F = 0$ or $M = \text{constant}$.

Thus, the zero shear force means that the bending moment is constant or the bending is same at every cross-section of the beam. Such a situation may be visualized or envisaged when the beam or some portion of the beam, as been loaded only by pure couples at its ends. It must be recalled that the couples are assumed to be loaded in the plane of symmetry.

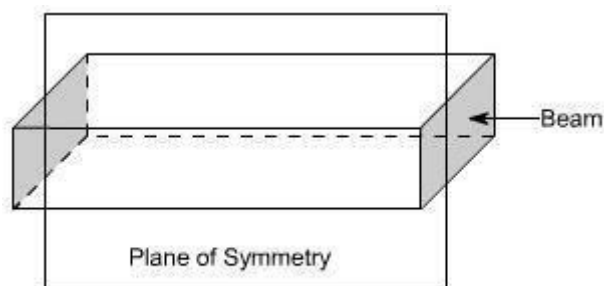

Fig (1)

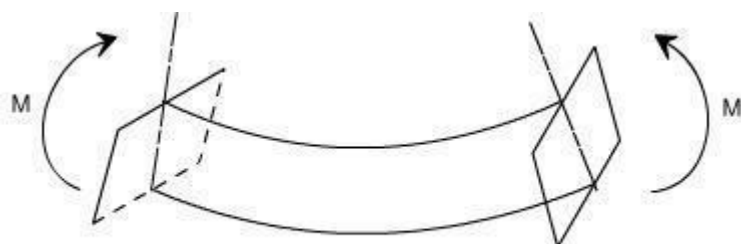
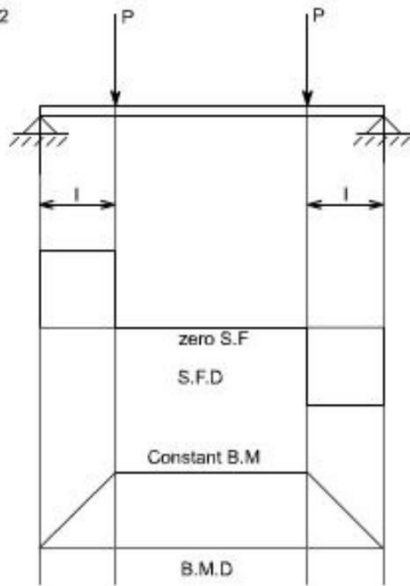

Fig (2)

When a member is loaded in such a fashion it is said to be in **pure bending**. The examples of pure bending have been indicated in EX 1 and EX 2 as shown below :

EX. 2



EX. 1

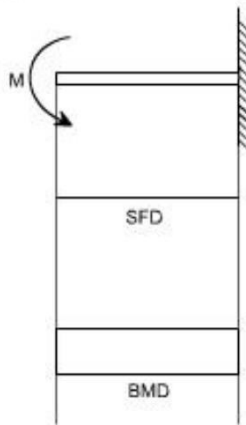

When a beam is subjected to pure bending or loaded by the couples at the ends, certain cross-section gets deformed and we shall have to make out the conclusion that,

1. Plane sections originally perpendicular to longitudinal axis of the beam remain plane and perpendicular to the longitudinal axis even after bending, i.e. the cross-section $A'E'$, $B'F'$ (refer Fig 1(a)) do not get warped or curved.
2. In the deformed section, the planes of this cross-section have a common intersection i.e. any time originally parallel to the longitudinal axis of the beam becomes an arc of circle.

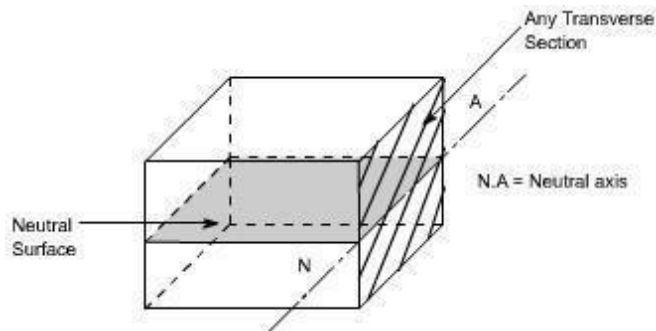

We know that when a beam is under bending the fibres at the top will be lengthened while at the bottom will be shortened provided the bending moment M acts at the ends. In between these there are some fibres which remain unchanged in length that is they are not strained, that is they do not carry any stress. The plane containing such fibres is called neutral surface.

The line of intersection between the neutral surface and the transverse exploratory section is called the neutral axis **(N A)** .

Bending Stresses in Beams or Derivation of Elastic Flexural formula :

In order to compute the value of bending stresses developed in a loaded beam, let us consider the two cross-sections of a beam **HE** and **GF** , originally parallel as shown in fig 1(a).when the beam is to bend it is assumed that these sections remain parallel i.e. **H'E'** and **G'F'** , the final position of the sections, are still straight lines, they then subtend some angle . |

Consider now fiber **AB** in the material, at adistance y from the N.A, when the beam bends this will stretch to **A'B'**

Therefore ,

$$\text{strain in fibre AB} = \frac{\text{change in length}}{\text{orginal length}}$$

$$= \frac{A'B' - AB}{AB}$$

$$\text{But } AB = CD \text{ and } CD = C'D'$$

refer to fig1(a) and fig1(b)

$$\therefore \text{strain} = \frac{A'B' - C'D'}{C'D'}$$

Since **CD** and **C'D'** are on the neutral axis and it is assumed that the Stress on the neutral axis zero. Therefore, there won't be any strain on the neutral axis

$$= \frac{(R + y)\theta - R\theta}{R\theta} = \frac{R\theta + y\theta - R\theta}{R\theta} = \frac{y}{R}$$

However $\frac{\text{stress}}{\text{strain}} = E$ where $E = \text{Young's Modulus of elasticity}$

Therefore ,equating the two strains as obtained from the two relations i.e,

$$\frac{\sigma}{E} = \frac{y}{R} \text{ or } \frac{\sigma}{y} = \frac{E}{R} \quad \dots\dots\dots(1)$$

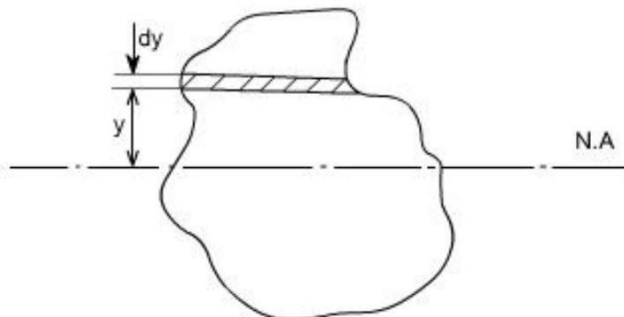

Consider any arbitrary a cross-section of beam, as shown above now the strain on a fibre at a distance 'y' from the N.A, is given by the expression

$$\sigma = \frac{E}{R} y$$

if the shaded strip is of area 'dA'

then the force on the strip is

$$F = \sigma \delta A = \frac{E}{R} y \delta A$$

Moment about the neutral axis would be $= F \cdot y = \frac{E}{R} y^2 \delta A$

The total moment for the whole cross-section is therefore equal to

$$M = \sum \frac{E}{R} y^2 \delta A = \frac{E}{R} \sum y^2 \delta A$$

Now the term $\sum y^2 \delta A$ is the property of the material and is called as a second moment of area of the cross-section and is denoted by a symbol I.

Therefore

$$M = \frac{E}{R} I \quad \dots\dots\dots(2)$$

combining equation 1 and 2 we get

$$\boxed{\frac{\sigma}{y} = \frac{M}{I} = \frac{E}{R}}$$

This equation is known as the Bending Theory Equation. The above proof has involved the assumption of pure bending without any shear force being present. Therefore this termed as the pure bending equation. This equation gives distribution of stresses which are normal to cross-section i.e. in x-direction.

Section Modulus:

From simple bending theory equation, the maximum stress obtained in any cross-section is given as

$$\sigma_{\max} = \frac{M}{I} y_{\max}$$

For any given allowable stress the maximum moment which can be accepted by a particular shape of cross-section is therefore

$$M = \frac{I}{y_{\max}} \sigma_{\max}$$

For ready comparison of the strength of various beam cross-section this relationship is some times written in the form

$$M = Z \sigma_{\max} \text{ where } Z = \frac{I}{y_{\max}} \text{ Is termed as section modulus}$$

The higher value of Z for a particular cross-section, the higher the bending moment which it can withstand for a given maximum stress.

Theorems to determine second moment of area: There are two theorems which are helpful to determine the value of second moment of area, which is required to be used while solving the simple bending theory equation.

Second Moment of Area :

Taking an analogy from the mass moment of inertia, the second moment of area is defined as the summation of areas times the distance squared from a fixed axis. (This property arised while we were driving bending theory equation). This is also known as the moment of inertia. An alternative name given to this is second moment of area, because the first moment being the sum of areas times their distance from a given axis and the second moment being the square of the distance or $\int y^2 dA$.

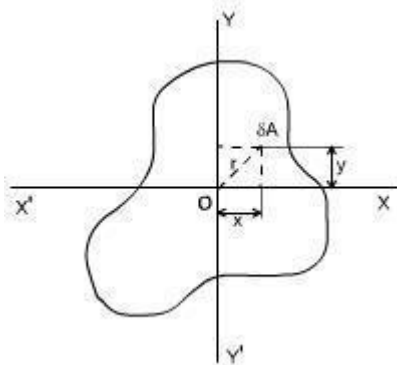

Consider any cross-section having small element of area d A then by the definition

$$I_x(\text{Mass Moment of Inertia about x-axis}) = \int y^2 dA \text{ and } I_y(\text{Mass Moment of Inertia about y-axis}) = \int x^2 dA$$

Now the moment of inertia about an axis through 'O' and perpendicular to the plane of figure is called the polar moment of inertia. (The polar moment of inertia is also the area moment of inertia).

i.e,

$$\begin{aligned} J &= \text{polar moment of inertia} \\ &= \int r^2 dA \\ &= \int (x^2 + y^2) dA \\ &= \int x^2 dA + \int y^2 dA \\ &= I_x + I_y \\ \text{or } J &= I_x + I_y \quad \dots\dots\dots (1) \end{aligned}$$

The relation (1) is known as the **perpendicular axis theorem** and may be stated as follows:

The sum of the Moment of Inertia about any two axes in the plane is equal to the moment of inertia about an axis perpendicular to the plane, the three axes being concurrent, i.e, the three axes exist together.

CIRCULAR SECTION :

For a circular x-section, the polar moment of inertia may be computed in the following manner

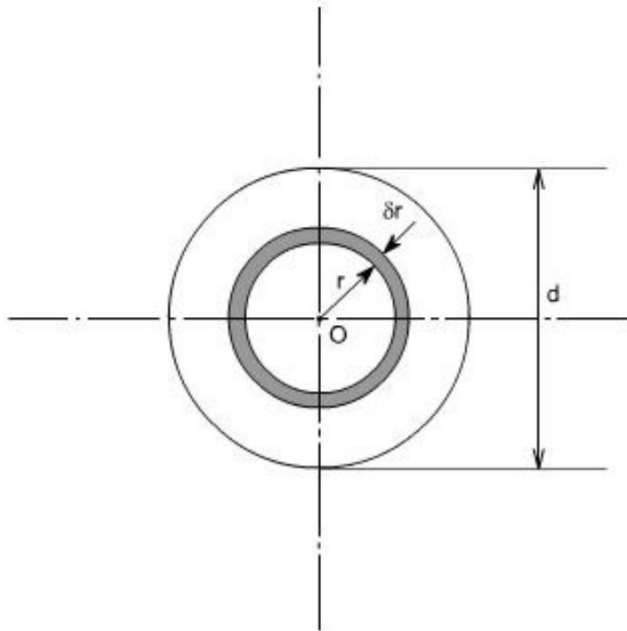

Consider any circular strip of thickness δr located at a radius 'r'.

Then the area of the circular strip would be $dA = 2\pi r \cdot \delta r$

$$J = \int r^2 dA$$

Taking the limits of integration from 0 to $d/2$

$$J = \int_0^{\frac{d}{2}} r^2 2\pi \delta r$$

$$= 2\pi \int_0^{\frac{d}{2}} r^3 \delta r$$

$$J = 2\pi \left[\frac{r^4}{4} \right]_0^{\frac{d}{2}} = \frac{\pi d^4}{32}$$

however, by perpendicular axis theorem

$$J = I_x + I_y$$

But for the circular cross-section, the I_x and I_y are both equal being moment of inertia about a diameter

$$I_{dia} = \frac{1}{2} J$$

$$I_{dia} = \frac{\pi d^4}{64}$$

for a hollow circular section of diameter D and d , the values of J and I are defined as

$$J = \frac{\pi(D^4 - d^4)}{32}$$

$$I = \frac{\pi(D^4 - d^4)}{64}$$

Thus

Parallel Axis Theorem:

The moment of inertia about any axis is equal to the moment of inertia about a parallel axis through the centroid plus the area times the square of the distance between the axes.

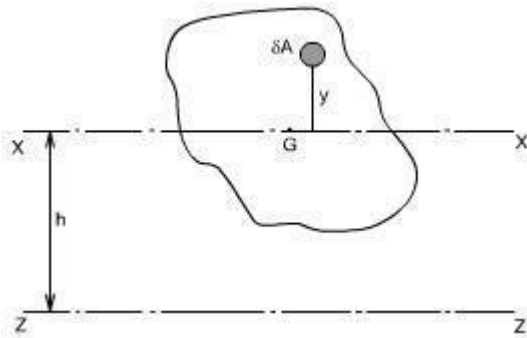

If 'ZZ' is any axis in the plane of cross-section and 'XX' is a parallel axis through the centroid G, of the cross-section, then

$$\begin{aligned}
 I_z &= \int (y + h)^2 dA \text{ by definition (moment of inertia about an axis ZZ)} \\
 &= \int (y^2 + 2yh + h^2) dA \\
 &= \int y^2 dA + h^2 \int dA + 2h \int y dA \\
 &\qquad\qquad\qquad \text{Since } \int y dA = 0 \\
 &= \int y^2 dA + h^2 \int dA \\
 &= \int y^2 dA + h^2 A
 \end{aligned}$$

$$I_z = I_x + Ah^2 \quad I_x = I_G \text{ (since cross-section axes also pass through G)}$$

Where A = Total area of the section

Rectangular Section:

For a rectangular x-section of the beam, the second moment of area may be computed as below :

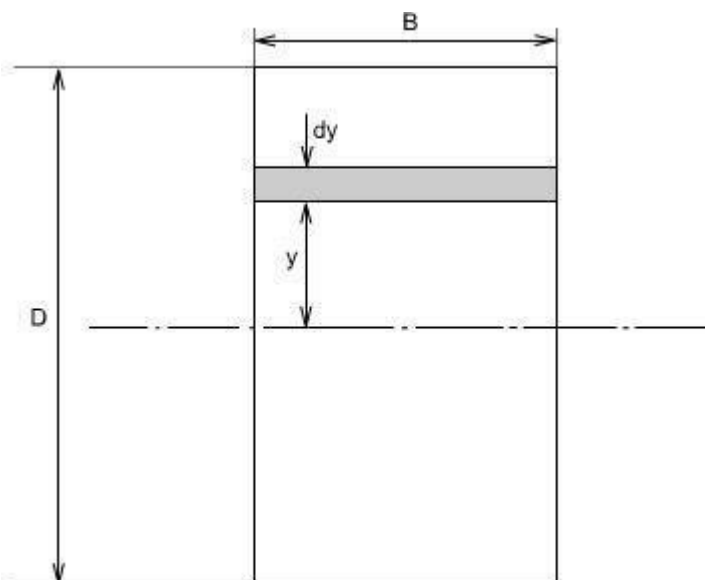

Consider the rectangular beam cross-section as shown above and an element of area dA , thickness dy , breadth B located at a distance y from the neutral axis, which by symmetry passes through the centre of section. The second moment of area I as defined earlier would be

$$I_{N.A} = \int y^2 dA$$

Thus, for the rectangular section the second moment of area about the neutral axis i.e., an axis through the centre is given by

$$\begin{aligned} I_{N.A} &= \int_{-\frac{D}{2}}^{\frac{D}{2}} y^2 (B dy) \\ &= B \int_{-\frac{D}{2}}^{\frac{D}{2}} y^2 dy \\ &= B \left[\frac{y^3}{3} \right]_{-\frac{D}{2}}^{\frac{D}{2}} \\ &= \frac{B}{3} \left[\frac{D^3}{8} - \left(\frac{-D^3}{8} \right) \right] \\ &= \frac{B}{3} \left[\frac{D^3}{8} + \frac{D^3}{8} \right] \\ I_{N.A} &= \frac{BD^3}{12} \end{aligned}$$

Similarly, the second moment of area of the rectangular section about an axis through the lower edge of the section would be found using the same procedure but with integral limits of 0 to D .

$$I = B \left[\frac{y^3}{3} \right]_0^D = \frac{BD^3}{3}$$

Therefore

These standard formulas prove very convenient in the determination of $I_{N.A}$ for build up sections which can be conveniently divided into rectangles. For instance if we just want to find out the Moment of Inertia of an I-section, then we can use the above relation.

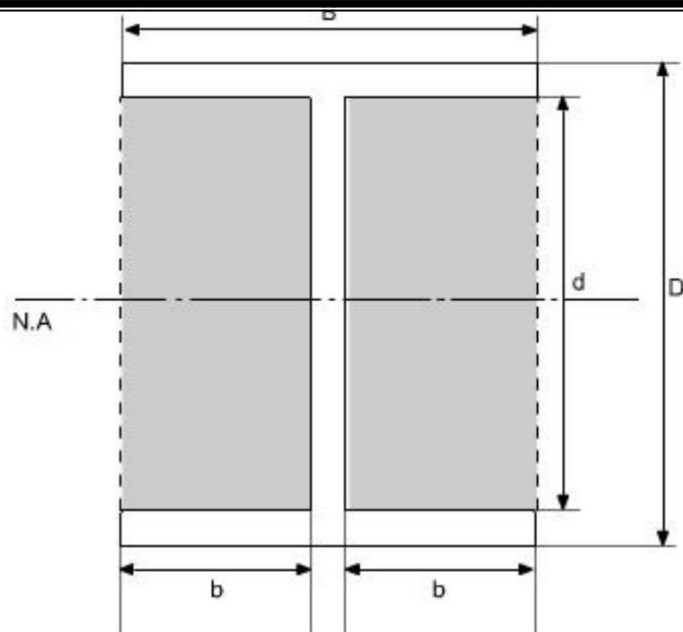

$$I_{N.A.} = I_{\text{of dotted rectangle}} - I_{\text{of shaded portion}}$$

$$\therefore I_{N.A.} = \frac{BD^3}{12} - 2 \left(\frac{bd^3}{12} \right)$$

$$I_{N.A.} = \frac{BD^3}{12} - \frac{bd^3}{6}$$

Use of Flexure Formula:

Illustrative Problems:

An I - section girder, 200mm wide by 300 mm depth flange and web of thickness is 20 mm is used as simply supported beam for a span of 7 m. The girder carries a distributed load of 5 KN /m and a concentrated load of 20 KN at mid-span.

Determine the

- (i). The second moment of area of the cross-section of the girder
- (ii). The maximum stress set up.

Solution:

The second moment of area of the cross-section can be determined as follows :

For sections with symmetry about the neutral axis, use can be made of standard I value for a rectangle about an axis through centroid i.e. $(bd^3)/12$. The section can thus be divided into convenient rectangles for each of which the neutral axis passes through the centroid. Example in the case enclosing the girder by a rectangle

Computation of Bending Moment:

In this case the loading of the beam is of two types

- (a) Uniformly distributed load
- (b) Concentrated Load

In order to obtain the maximum bending moment the technique will be to consider each loading on the beam separately and get the bending moment due to it as if no other forces acting on the structure and then superimpose the two results.

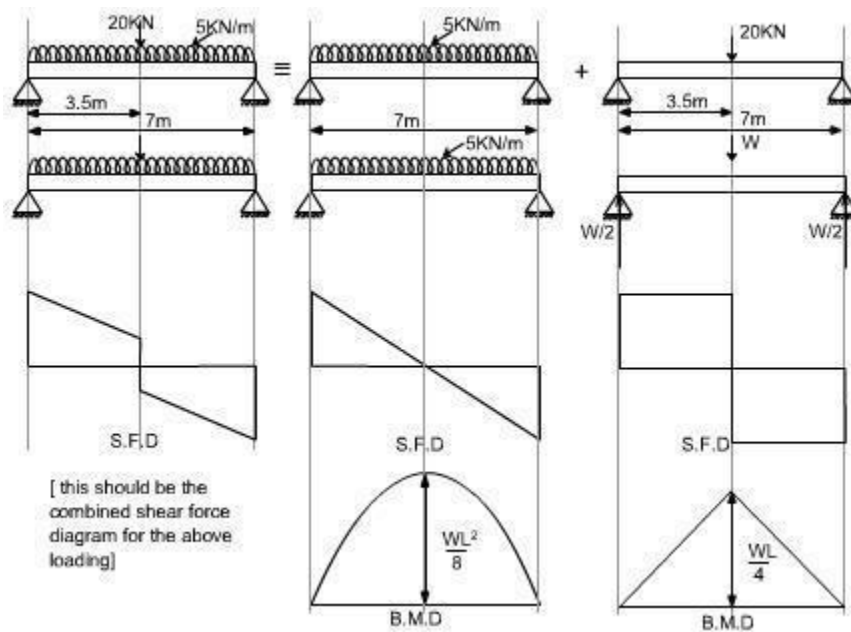

Hence

$$\begin{aligned}M_{\max} &= \frac{wL}{4} + \frac{wL^2}{8} \\&= \frac{20 \times 10^3 \times 7}{4} + \frac{5 \times 10^3 \times 7^2}{8} \\&= (35.0 + 30.63) 10^3 \\&= 65.63 \text{ kNm} \\ \sigma_{\max} &= \frac{M_{\max}}{I} y_{\max} \\&= \frac{65.63 \times 10^3 \times 150 \times 10^3}{1.06 \times 10^{-4}} \\ \sigma_{\max} &= 51.8 \text{ MN/m}^2\end{aligned}$$

Shearing Stresses in Beams

All the theory which has been discussed earlier, while we discussed the bending stresses in beams was for the case of pure bending i.e. constant bending moment acts along the entire length of the beam.

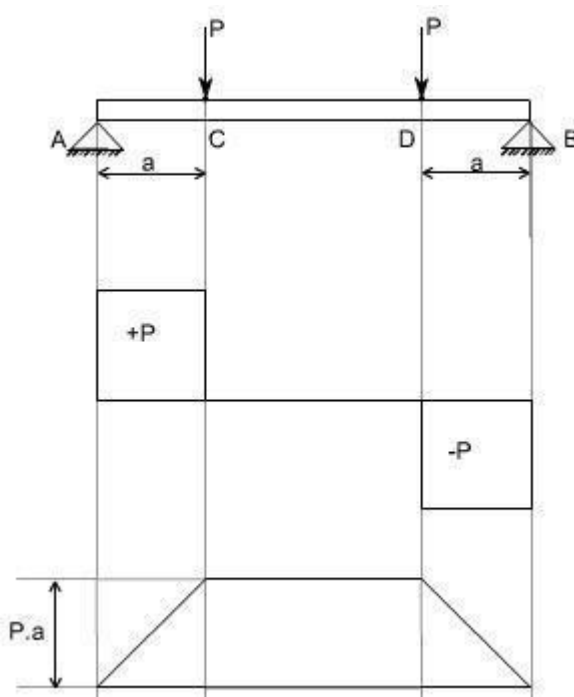

Let us consider the beam AB transversely loaded as shown in the figure above. Together with shear force and bending moment diagrams we note that the middle portion CD of the beam is free from shear force and that its bending moment, $M = P \cdot a$ is uniform between the portion C and D. This condition is called the pure bending condition.

Since shear force and bending moment are related to each other $F = \frac{dM}{dX}$ (eq) therefore if the shear force changes then there will be a change in the bending moment also, and then this won't be the pure bending.

Conclusions :

Hence one can conclude from the pure bending theory was that the shear force at each X-section is zero and the normal stresses due to bending are the only ones produced.

In the case of non-uniform bending of a beam where the bending moment varies from one X-section to another, there is a shearing force on each X-section and shearing stresses are also induced in the material. The deformation associated with those shearing stresses causes “warping” of the x-section

$$\frac{\sigma}{y} = \frac{M}{I} = \frac{E}{R}$$

so that the assumption which we assumed while deriving the relation that the plane cross-section after bending remains plane is violated. Now due to warping the plane cross-section before bending do not remain plane after bending. This complicates the problem but more elaborate analysis

$$\frac{\sigma}{y} = \frac{M}{I} = \frac{E}{R}$$

shows that the normal stresses due to bending, as calculated from the equation

The above equation gives the distribution of stresses which are normal to the cross-section that is in x-direction or along the span of the beam are not greatly altered by the presence of these shearing stresses. Thus, it is justifiable to use the theory of pure bending in the case of non uniform bending and it is accepted practice to do so.

Let us study the shear stresses in the beams.

Concept of Shear Stresses in Beams :

By the earlier discussion we have seen that the bending moment represents the resultant of certain linear distribution of normal stresses σ over the cross-section. Similarly, the shear force F_x over any cross-section must be the resultant of a certain distribution of shear stresses.

Derivation of equation for shearing stress :

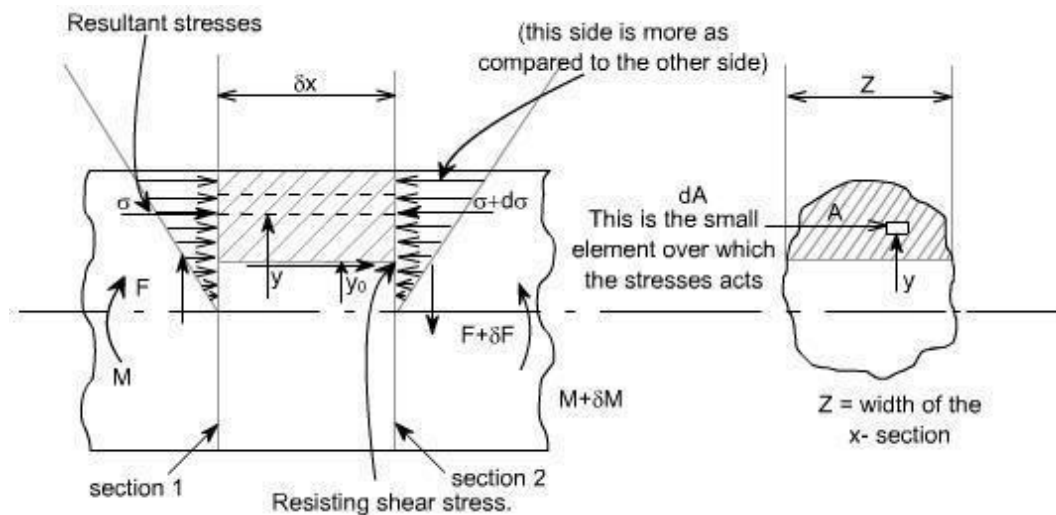

Assumptions :

1. Stress is uniform across the width (i.e. parallel to the neutral axis)
2. The presence of the shear stress does not affect the distribution of normal bending stresses.

It may be noted that the assumption no.2 cannot be rigidly true as the existence of shear stress will cause a distortion of transverse planes, which will no longer remain plane.

In the above figure let us consider the two transverse sections which are at a distance δx apart. The shearing forces and bending moments being F , $F + \delta F$ and M , $M + \delta M$ respectively. Now due to the shear stress on transverse planes there will be a complementary shear stress on longitudinal planes parallel to the neutral axis.

□

□

$$\text{i.e. } \tau \cdot z \delta x = \int d\sigma \cdot dA$$

from the bending theory equation

$$\frac{\sigma}{y} = \frac{M}{I}$$

$$\sigma = \frac{M \cdot y}{I}$$

$$\sigma + d\sigma = \frac{(M + \delta M) \cdot y}{I}$$

$$\text{Thus } d\sigma = \frac{\delta M \cdot y}{I}$$

The figure shown below indicates the pictorial representation of the part.

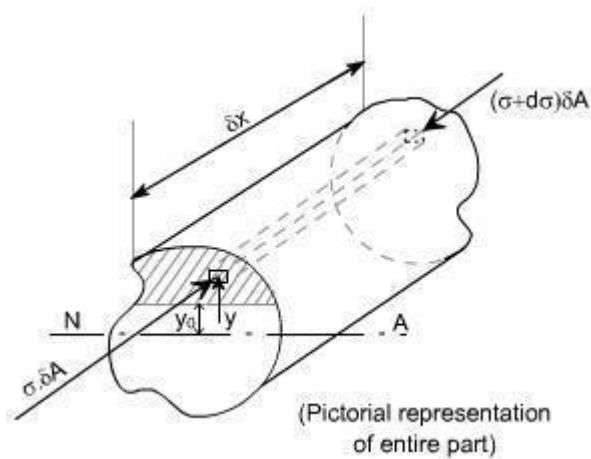

$$d\sigma = \frac{\delta M \cdot y}{I}$$

$$\tau \cdot z \delta x = \int d\sigma \cdot dA$$

$$= \int \frac{\delta M \cdot y \cdot \delta A}{I}$$

$$\tau \cdot z \delta x = \frac{\delta M}{I} \int y \cdot \delta A$$

But $F = \frac{\delta M}{\delta x}$

i.e. $\tau = \frac{F}{I \cdot z} \int y \cdot \delta A$

But from definition, $\int y \cdot dA = A \bar{y}$

$\int y \cdot dA$ is the first moment of area of the shaded portion

and \bar{y} = centroid of the area 'A'

Hence

$$\tau = \frac{F \cdot A \cdot \bar{y}}{I \cdot z}$$

So substituting

Where 'z' is the actual width of the section at the position where 'I' is being calculated and I is the total moment of inertia about the neutral axis.

Shearing stress distribution in typical cross-sections:

Let us consider few examples to determine the shear stress distribution in a given X- sections

Rectangular x-section:

Consider a rectangular x-section of dimension b and d

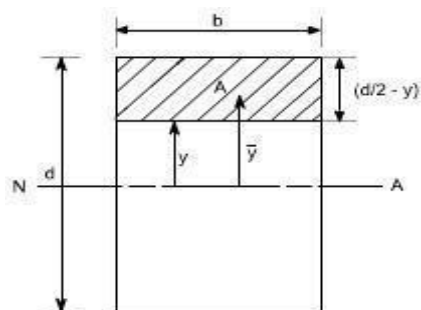

A is the area of the x-section cut off by a line parallel to the neutral axis. \bar{y} is the distance of the centroid of A from the neutral axis

$$\tau = \frac{F.A.\bar{y}}{l.z}$$

for this case, $A = b\left(\frac{d}{2} - y\right)$

While $\bar{y} = \left[\frac{1}{2}\left(\frac{d}{2} - y\right) + y \right]$

i.e $\bar{y} = \frac{1}{2}\left(\frac{d}{2} + y\right)$ and $z = b; l = \frac{b.d^3}{12}$

substituting all these values, in the formula

$$\begin{aligned} \tau &= \frac{F.A.\bar{y}}{l.z} \\ &= \frac{F.b.\left(\frac{d}{2} - y\right) \cdot \frac{1}{2}\left(\frac{d}{2} + y\right)}{\frac{b.d^3}{12}} \\ &= \frac{F}{2} \left\{ \left(\frac{d}{2}\right)^2 - y^2 \right\} \\ &= \frac{6.F}{b.d^3} \left\{ \left(\frac{d}{2}\right)^2 - y^2 \right\} \end{aligned}$$

This shows that there is a parabolic distribution of shear stress with y .

The maximum value of shear stress would obviously be at the location $y = 0$.

$$\begin{aligned} \text{Such that } \tau_{\max} &= \frac{6.F}{b.d^3} \cdot \frac{d^2}{4} \\ &= \frac{3.F}{2.b.d} \end{aligned}$$

So $\tau_{\max} = \frac{3.F}{2.b.d}$ The value of τ_{\max} occurs at the neutral axis

The mean shear stress in the beam is defined as

$$\tau_{\text{mean or } \tau_{\text{avg}}} = \frac{F}{A} = \frac{F}{b.d}$$

So $\tau_{\max} = 1.5 \tau_{\text{mean}} = 1.5 \tau_{\text{avg}}$

Therefore the shear stress distribution is shown as below.

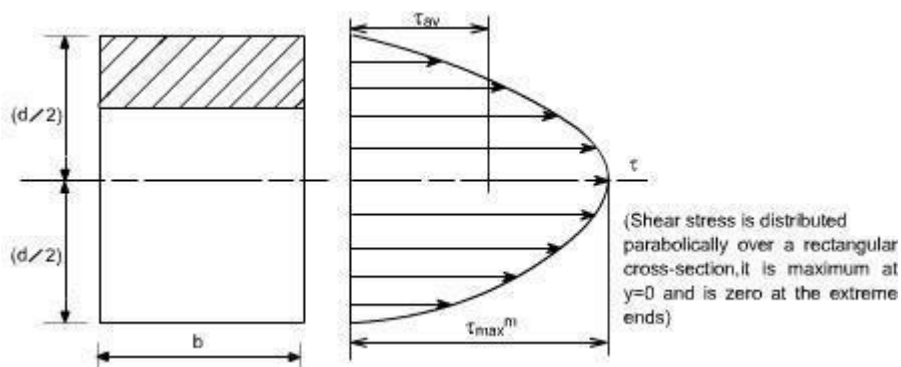

It may be noted that the shear stress is distributed parabolically over a rectangular cross-section, it is maximum at $y = 0$ and is zero at the extreme ends.

I - section :

Consider an I - section of the dimension shown below.

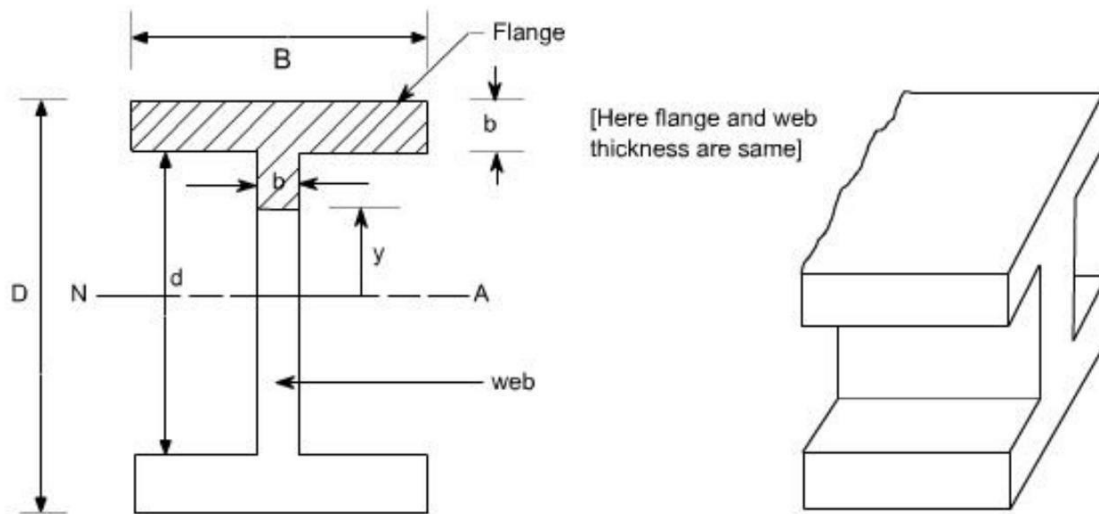

The shear stress distribution for any arbitrary shape is given as $\tau = \frac{F A \bar{y}}{Z I}$

Let us evaluate the quantity $A\bar{y}$, the $A\bar{y}$ quantity for this case comprise the contribution due to flange area and web area

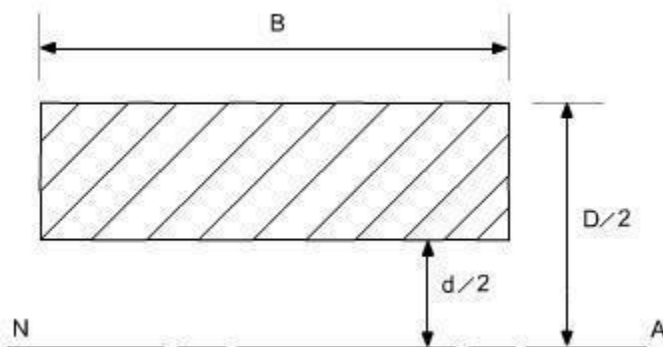

Flange area

$$\text{Area of the flange} = B \left(\frac{D - d}{2} \right)$$

Distance of the centroid of the flange from the N.A.

$$\bar{y} = \frac{1}{2} \left(\frac{D - d}{2} \right) + \frac{d}{2}$$

$$\bar{y} = \left(\frac{D + d}{4} \right)$$

Hence,

$$A\bar{y}|_{\text{Flange}} = B \left(\frac{D - d}{2} \right) \left(\frac{D + d}{4} \right)$$

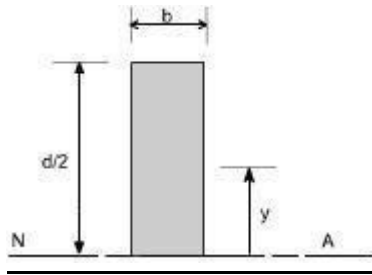

Web Area

Area of the web

$$A = b \left(\frac{d}{2} - y \right)$$

Distance of the centroid from N.A

$$\bar{y} = \frac{1}{2} \left(\frac{d}{2} - y \right) + y$$

$$\bar{y} = \frac{1}{2} \left(\frac{d}{2} + y \right)$$

Therefore,

$$A\bar{y}|_{web} = b \left(\frac{d}{2} - y \right) \frac{1}{2} \left(\frac{d}{2} + y \right)$$

Hence,

$$A\bar{y}|_{Total} = B \left(\frac{D-d}{2} \right) \left(\frac{D+d}{4} \right) + b \left(\frac{d}{2} - y \right) \left(\frac{d}{2} + y \right) \frac{1}{2}$$

Thus,

$$A\bar{y}|_{Total} = B \left(\frac{D^2 - d^2}{8} \right) + \frac{b}{2} \left(\frac{d^2}{4} - y^2 \right)$$

Therefore shear stress,

$$\tau = \frac{F}{bI} \left[\frac{B(D^2 - d^2)}{8} + \frac{b}{2} \left(\frac{d^2}{4} - y^2 \right) \right]$$

To get the maximum and minimum values of τ substitute in the above relation.

$y = 0$ at N. A. And $y = d/2$ at the tip.

The maximum shear stress is at the neutral axis. i.e. for the condition $y = 0$ at N. A.

Hence, τ_{max} at $y = 0 = \frac{F}{8bI} \left[B(D^2 - d^2) + bd^2 \right]$ (2)

The minimum stress occur at the top of the web, the term $bd^2/2$ goes off and shear stress is given by the following expression

τ_{min} at $y = d/2 = \frac{F}{8bI} \left[B(D^2 - d^2) \right]$ (3)

The distribution of shear stress may be drawn as below, which clearly indicates a parabolic distribution

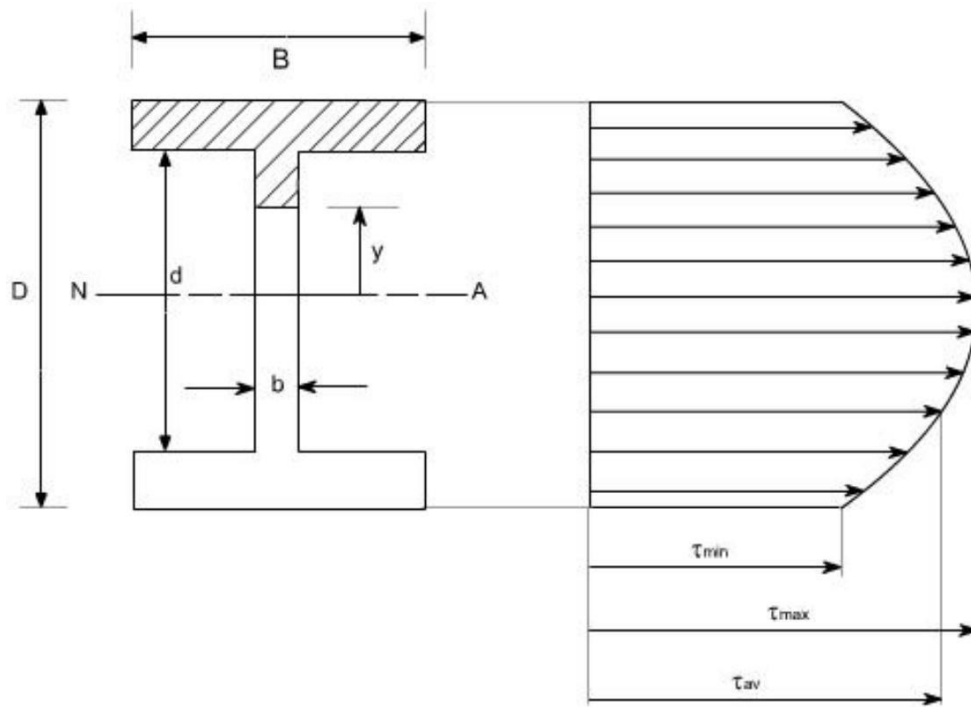

$$\tau_{\max}^m = \frac{F}{8bl} \left[B(D^2 - d^2) + bd^2 \right]$$

Note: from the above distribution we can see that the shear stress at the flanges is not zero, but it has some value, this can be analyzed from equation (1). At the flange tip or flange or web interface $y = d/2$. Obviously than this will have some constant value and than onwards this will have parabolic distribution.

In practice it is usually found that most of shearing stress usually about 95% is carried by the web, and hence the shear stress in the flange is negligible however if we have the concrete analysis i.e. if we analyze the shearing stress in the flange i.e. writing down the expression for shear stress for flange and web separately, we will have this type of variation.

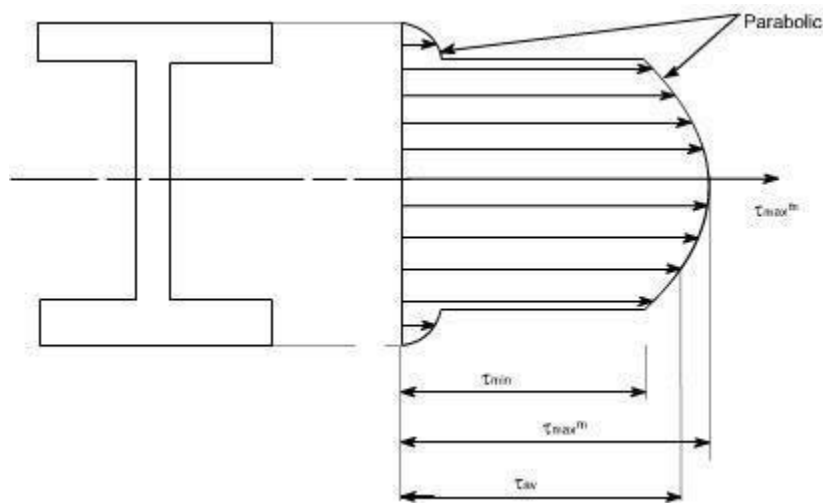

This distribution is known as the “top – hat” distribution. Clearly the web bears the most of the shear stress and bending theory we can say that the flange will bear most of the bending stress.

Shear stress distribution in beams of circular cross-section:

Let us find the shear stress distribution in beams of circular cross-section. In a beam of circular cross-section, the value of Z width depends on y.

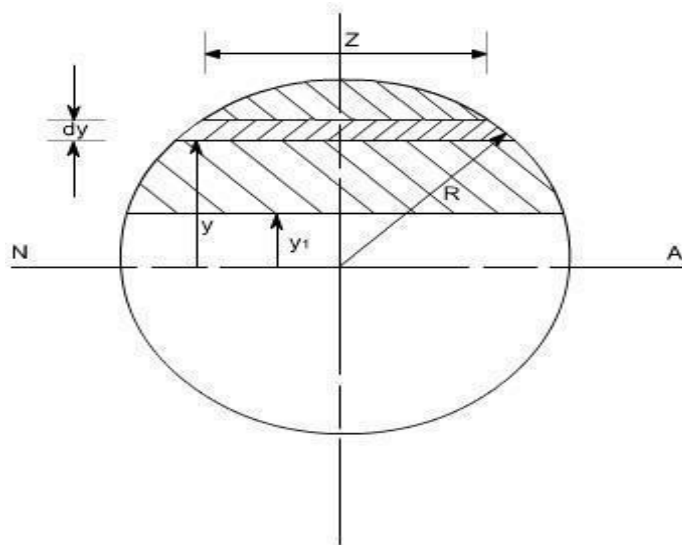

Using the expression for the determination of shear stresses for any arbitrary shape or a arbitrary section.

$$\tau = \frac{FA \bar{y}}{Zl} = \frac{FA \int y dA}{Zl}$$

Where $\int y dA$ is the area moment of the shaded portion or the first moment of area.

Here in this case 'dA' is to be found out using the Pythagoras theorem

$$\left(\frac{Z}{2}\right)^2 + y^2 = R^2$$

$$\left(\frac{Z}{2}\right)^2 = R^2 - y^2 \text{ or } \frac{Z}{2} = \sqrt{R^2 - y^2}$$

$$Z = 2\sqrt{R^2 - y^2}$$

$$dA = Z dy = 2\sqrt{R^2 - y^2} \cdot dy$$

$$I_{N.A} \text{ for a circular cross-section} = \frac{\pi R^4}{4}$$

Hence,

$$\tau = \frac{FA \bar{y}}{Zl} = \frac{F}{\frac{\pi R^4}{4} \cdot 2\sqrt{R^2 - y^2}} \int_{y_1}^R 2y\sqrt{R^2 - y^2} dy$$

Where R = radius of the circle.

[The limits have been taken from y_1 to R because we have to find moment of area the shaded portion]

$$= \frac{4F}{\pi R^4 \sqrt{R^2 - y^2}} \int_{y_1}^R y\sqrt{R^2 - y^2} dy$$

The integration yields the final result to be

$$\tau = \frac{4F(R^2 - y_1^2)}{3\pi R^4}$$

Again this is a parabolic distribution of shear stress, having a maximum value when $y_1 = 0$

$$\tau_{\max} |_{y_1 = 0} = \frac{4F}{3\pi R^2}$$

Obviously at the ends of the diameter the value of $y_1 = \pm R$ thus $\tau = 0$ so this is again a parabolic distribution; maximum at the neutral axis

Also

$$\tau_{\text{avg}} \text{ or } \tau_{\text{mean}} = \frac{F}{A} = \frac{F}{\pi R^2}$$

Hence,

$$\tau_{\max} = \frac{4}{3} \tau_{\text{avg}}$$