



MALLA REDDY COLLEGE OF ENGINEERING & TECHNOLOGY

(AUTONOMOUS INSTITUTION – UGC, GOVT. OF INDIA)

**B.Tech
Aeronautical
Engineering**

Department of AERONAUTICAL ENGINEERING



FINITE ELEMENT ANALYSIS (R20A2137)

Prepared by:

**M.Yugender
Assistant Professor
Department of ANE
yugender@mrcet.ac.in**

FINITE ELEMENT ANALYSIS (R20A2137)



DIGITAL NOTES

**B.TECH (R-20 Regulation)
(III YEAR – II SEM)
(2023-24)**

DEPARTMENT AERONAUTICAL ENGINEERING



**MALLA REDDY COLLEGE OF ENGINEERING &
TECHNOLOGY**

(Autonomous Institution – UGC, Govt. of India)

Recognized under 2(f) and 12 (B) of UGC ACT 1956

(Affiliated to JNTUH, Hyderabad, Approved by AICTE - Accredited by NBA & NAAC – 'A' Grade - ISO 9001:2015 Certified)
Maisammaguda, Dhulapally (Post Via. Hakimpet), Secunderabad – 500100, Telangana State, India

Department of AERONAUTICAL ENGIERRING

Vision

- Department of Aeronautical Engineering aims to be indispensable source in Aeronautical Engineering which has a zeal to provide the value driven platform for the students to acquire knowledge and empower themselves to shoulder higher responsibility in building a strong nation..

Mission

- The primary mission of the department is to promote engineering education and research. To strive consistently to provide quality education, keeping in pace with time and technology. Department passions to integrate the intellectual, spiritual, ethical, and social development of the students for shaping them into dynamic engineers.

QUALITY POLICY

- Impart up-to date knowledge to the students in Aeronautical area to make them quality engineers. Make the students experience the applications on quality equipment and tools. Provide systems, resources, and training opportunities to achieve continuous improvement. Maintain global standards in education, training, and services.

PROGRAM OUTCOMES (PO's)

Engineering Graduates will be able to:

- Engineering knowledge: Apply the knowledge of mathematics, science, engineering fundamentals, and an engineering specialization to the solution of complex engineering problems.
- Problem analysis: Identify, formulate, review research literature, and analyze complex engineering problems reaching substantiated conclusions using first principles of mathematics, natural sciences, and engineering sciences.
- Design / development of solutions: Design solutions for complex engineering problems and design system components or processes that meet the specified needs with appropriate consideration for the public health and safety, and the cultural, societal and environmental considerations.
- Conduct investigations of complex problems: Use research-based knowledge and research methods including design of experiments, analysis and interpretation of data, and synthesis of the information to provide valid conclusions.
- Modern tool usage: Create, select, and apply appropriate techniques, resources, and modern engineering and IT tools including prediction and modeling to complex engineering activities with an understanding of the limitations.
- The engineer and society: Apply reasoning informed by the contextual knowledge to assess societal, health, safety, legal and cultural issues and the consequent responsibilities relevant to the professional engineering practice.
- Environment and sustainability: Understand the impact of the professional engineering solutions in societal and environmental contexts, and demonstrate the knowledge of, and need for sustainable development.
- Ethics: Apply ethical principles and commit to professional ethics and

responsibilities and norms of the engineering practice. Individual and team work: Function effectively as an individual, and as a member or leader in diverse teams, and in multidisciplinary settings.

- **Communication:** Communicate effectively on complex engineering activities with the engineering community and with society at large, such as, being able to comprehend and write effective reports and design documentation, make effective presentations, and give and receive clear instructions.
- **Project management and finance:** Demonstrate knowledge and understanding of the engineering and management principles and apply these to one's own work, as a member and leader in a team, to manage projects and in multi disciplinary environments.
- **Life- long learning:** Recognize the need for, and have the preparation and ability to engage in independent and life-long learning in the broadest context of technological change.

PROGRAM EDUCATIONAL OBJECTIVES – Aeronautical Engineering

- PEO1 (PROFESSIONALISM & CITIZENSHIP): To create and sustain a community of learning in which students acquire knowledge and learn to apply it professionally with due consideration for ethical, ecological and economic issues.
- PEO2 (TECHNICAL ACCOMPLISHMENTS): To provide knowledge based services to satisfy the needs of society and the industry by providing hands on experience in various technologies in core field.
- PEO3 (INVENTION, INNOVATION AND CREATIVITY): To make the students to design, experiment, analyze, and interpret in the core field with the help of other multi disciplinary concepts wherever applicable.
- PEO4 (PROFESSIONAL DEVELOPMENT): To educate the students to disseminate research findings with good soft skills and become a successful entrepreneur.
- PEO5 (HUMAN RESOURCE DEVELOPMENT): To graduate the students in building national capabilities in technology, education and research

PROGRAM SPECIFIC OUTCOMES – Aeronautical Engineering

- To mould students to become a professional with all necessary skills, personality and sound knowledge in basic and advance technological areas.
- To promote understanding of concepts and develop ability in design manufacture and maintenance of aircraft, aerospace vehicles and associated equipment and develop application capability of the concepts sciences to engineering design and processes.
- Understanding the current scenario in the field of aeronautics and acquire ability to apply knowledge of engineering, science and mathematics to design and conduct experiments in the field of Aeronautical Engineering.
- 4. To develop leadership skills in our students necessary to shape the social, intellectual, business and technical worlds.

MALLA REDDY COLLEGE OF ENGINEERING AND TECHNOLOGY

III Year B. TECH – II- SEM ANE

L/T/P/C
4/-/-/4**(R20A2137) FINITE ELEMENT ANALYSIS****OBJECTIVES:**

- It covers the fundamental theoretical approach beginning with a review of differential equations, boundary conditions, integral forms, interpolation, parametric geometry, numerical integration, and matrix algebra.
- Next, engineering applications to field analysis, stress analysis and vibrations are introduced. Time dependent problems are also treated.
- Students are also introduced, by means of selected tutorials, to the commercial finite element system Solid Works which is similar to one they could be expected to use upon graduation. Graduate students will also be introduced to the more powerful (and difficult to use) Ansys system.

Unit– I

Introduction to Finite Element Method for solving field problems. Stress and Equilibrium. Strain – Displacement relations. Stress – strain relations. One Dimensional problems: Finite element modeling coordinates and shape functions. Potential Energy approach: Assembly of Global stiffness matrix and load vector. Finite element equations, Treatment of boundary conditions, Quadratic shape functions.

Unit – II

Analysis of Beams: Element stiffness matrix for two node, two degrees of freedom per node beam element.

Analysis of Trusses: Stiffness matrix for plain truss elements, stress calculations and problems.

Unit – III

Finite element modelling of two dimensional stress analysis with constant strain triangles and treatment of boundary conditions. Finite element modelling of Axisymmetric solids subjected to Axisymmetric loading with triangular elements. Two dimensional four noded isoperimetric elements and numerical integration.

Unit – IV

Steady state heat transfer analysis: one dimensional analysis of a fin and two dimensional analysis of thin plate.

Unit – V

Dynamic Analysis: Formulation of finite element model, element matrices, evaluation of Eigen values and Eigen vectors for a stepped bar and a beam.

TEXT BOOKS:

1. Introduction to Finite Elements in Engineering / Chandraputla, Ashok and Belegundu /Prentice – Hall.
 2. The Finite Element Methods in Engineering / SS Rao / Pergamon.
 3. The Finite Element Method for Engineers – Kenneth H. Huebner, Donald L. Dewhirst, Douglas E. Smith and Ted
- G. Byrom / John Wiley & sons (ASIA) Pte Ltd.

Code No: R20A2137

MALLA REDDY COLLEGE OF ENGINEERING & TECHNOLOGY

(Autonomous Institution – UGC, Govt. of India)

III B.Tech II Semester Regular Examinations, May 2023

Finite Element Analysis

(AE)

Time: 3 hours

Max. Marks: 70

Note: This question paper Consists of 5 Sections. Answer **FIVE** Questions, Choosing **ONE** Question from each SECTION and each Question carries 14 marks.

SECTION-I

- 1 For a tapered bar as shown in figure, find the displacements at the nodes by forming into two element model. In addition to self weight, the bar is subjected to a point load of $P=1\text{kN}$ at the free end. Also find the reaction forces. [5M]

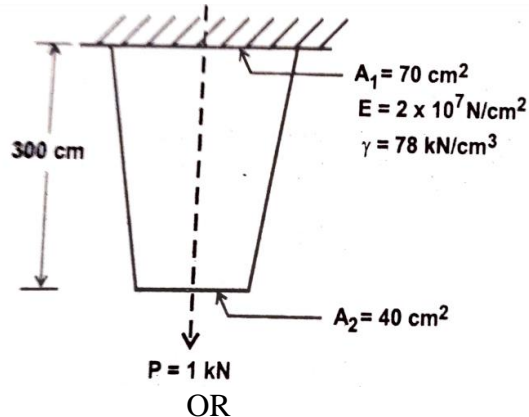

- 2 stepped bar is subjected to an axial load of 300 kN at 20°C as shown in fig. The temperature is then raised to 60°C . Determine (a) the nodal displacements (b) stresses in each material and (c) support reactions. [14M]

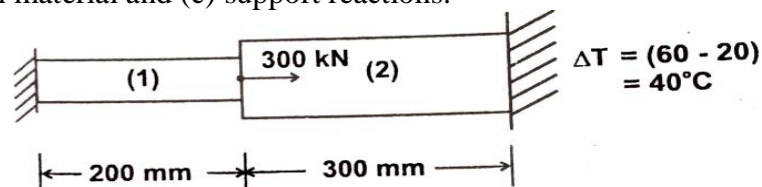

(1) Aluminium
 $E_1 = 70 \times 10^3 \text{ N/mm}^2$
 $A_1 = 900 \text{ mm}^2$
 $\alpha_1 = 23 \times 10^{-6} \text{ mm/mm}^\circ\text{C}$
 $l_1 = 200 \text{ mm}$

(2) Steel
 $E_2 = 200 \times 10^3 \text{ N/mm}^2$
 $A_2 = 1200 \text{ mm}^2$
 $\alpha_2 = 12 \times 10^{-6} \text{ mm/mm}^\circ\text{C}$
 $l_2 = 300 \text{ mm}$.

SECTION-II

- 3 Using two equal length beam elements determine central deflection and slope at supports in simply supported beam of span 3 m carrying a central point load of 20 kN. Take $EI=8000 \text{ kNm}^2$ and make use of symmetry. [14M]

OR

- 4 In the two-member truss shown in Fig., let $\theta_1 = 45^\circ$, $\theta_2 = 15^\circ$, $x_1 = y_1 = 0$, $E_1 = E_2 = 200 \text{ GPa}$, $A_1 = A_2 = 900 \text{ mm}^2$, $F_{3x} = 500 \text{ N}$ and $F_{3y} = 300 \text{ N}$. determine the displacement components of node 3. [14M]

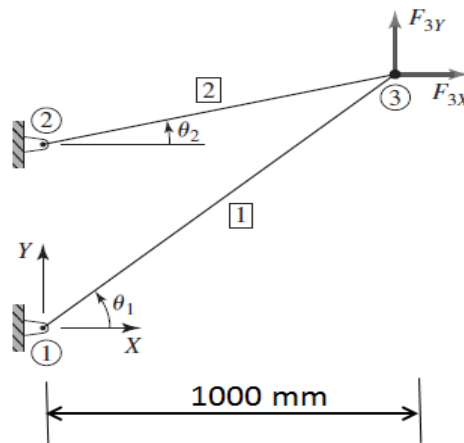
SECTION-III

- 5 Examine the shape functions for four-noded rectangular element by using natural coordinate system. [14M]

OR

- 6 Derive shape functions for three noded triangular element. [14M]

SECTION-IV

- 7 Derive a finite element equation for two-dimensional steady state heat conduction problems. [14M]

OR

- 8 A wall of 0.6 m thickness having thermal conductivity of 1.2 W/mK. The wall is to be insulated with a material of thickness 0.06 m having an average thermal conductivity of 0.3 W/mK. The inner surface temperature is 1000°C and outside of the insulated is exposed to atmospheric air at 30°C with heat transfer coefficient of $35 \text{ W/m}^2\text{K}$. Calculate the nodal temperatures. [14M]

SECTION-V

- 9 Consider a uniform cross section bar of length 'L' made up of a material whose Young's modulus and density are given by E and ρ . Estimate the natural [14M]

frequencies of axial vibration of the bar using both consistent and lumped mass matrices.

OR

- 10** For the stepped bar shown in Fig. Develop the global stiffness and mass matrices **[14M]** and also determine the natural frequencies and mode shapes. Assume $E=200$ GPa and mass density $=7850$ Kg/m³, $L_1=L_2=0.3$ m $A_1=350$ mm² $A_2=600$ mm².

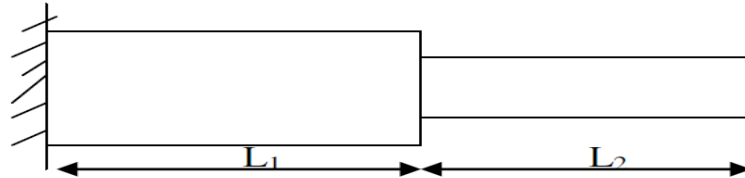

Code No: R18A2114

MALLA REDDY COLLEGE OF ENGINEERING & TECHNOLOGY

(Autonomous Institution – UGC, Govt. of India)

III B.Tech II Semester Supplementary Examinations, April 2023

Finite Element Analysis

(AE)

Time: 3 hours

Max. Marks: 70

Note: This question paper Consists of 5 Sections. Answer **FIVE** Questions, Choosing **ONE** Question from each SECTION and each Question carries 14 marks.

SECTION-I

- 1 Derive and assemble global stiffness matrix for 1-D bar element [14M]

OR

- 2 Define shape function? Derive the shape function of 1-D bar element using global coordinates. [14M]

SECTION-II

- 3 For the three stepped bar shown in figure, determine the displacements at node 2 and 3 and stresses. [14M]

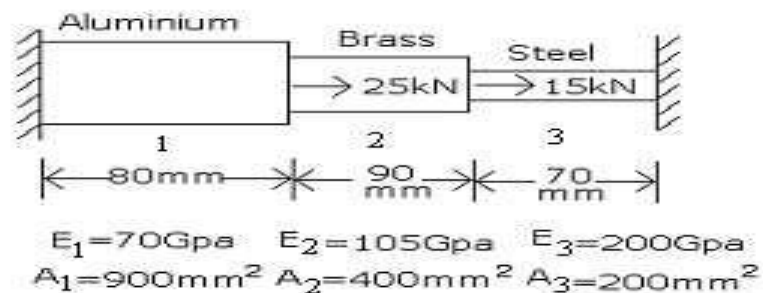

OR

- 4 For the two bar truss shown in fig, determine the displacements of node 1 and the stress in element 1-3. Take $E = 70 \text{ GPa}$, $A = 200 \text{ mm}^2$, Point load at node 1 = 12 kN [14M]

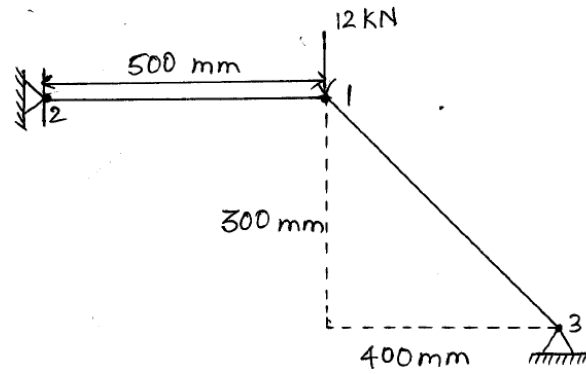

SECTION-III

- 5 (i) Explain briefly iso-parametric, sub- parametric and super-parametric elements [6M]
- (ii) For the isoparametric quadrilateral element shown in figure. Determine the local coordinates of the point 'P' which has Cartesian co-ordinates (7, 4). [8M]

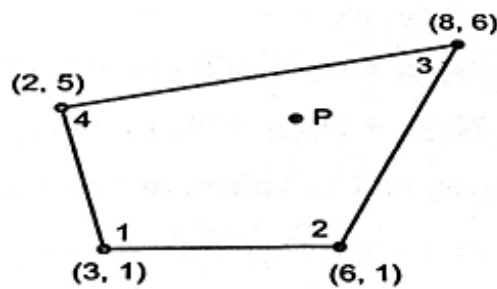

OR

- 6 For the axisymmetric elements shown in fig. determine the element stresses. [14M]

Let $E = 2.1 \times 10^5 \text{ N/mm}^2$ and $\nu = 0.25$. The co-ordinates shown in fig are in mm. The nodal displacements are

$u_1 = 0.05 \text{ mm}$	$w_1 = 0.03 \text{ mm}$
$u_2 = 0.02 \text{ mm}$	$w_2 = 0.02 \text{ mm}$
$u_3 = 0 \text{ mm}$	$w_3 = 0 \text{ mm}$

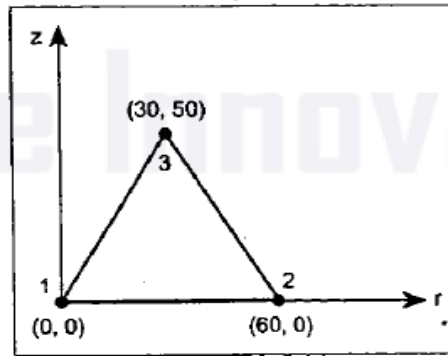
**SECTION-IV**

- 7 Calculate the temperature distribution in a one dimension fin with physical properties given in figure. The fin is rectangular in shape and is 120 mm long, 40 mm wide and 10 mm thick. Assume that convection heat loss occurs from the end of fin. Use two elements. Take $k = 0.3 \text{ W/mm}^\circ\text{C}$, $h = 1 \times 10^{-3} \text{ W/mm}^2 \text{ }^\circ\text{C}$, $T_\infty = 20^\circ\text{C}$. [14M]

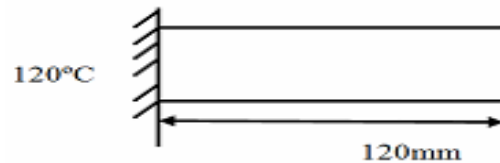

OR

- 8 Discuss the two dimensional analysis of thin plate with a suitable example [14M]

SECTION-V

- 9 For the stepped bar shown in figure. Develop the global stiffness and mass matrices and also determine the natural frequencies and mode shapes. Assume $E = 200 \text{ GPa}$ and mass density $= 7850 \text{ kg/m}^3$, $L_1 = L_2 = 0.3 \text{ m}$, $A_1 = 350 \text{ mm}^2$ & $A_2 = 600 \text{ mm}^2$ [14M]

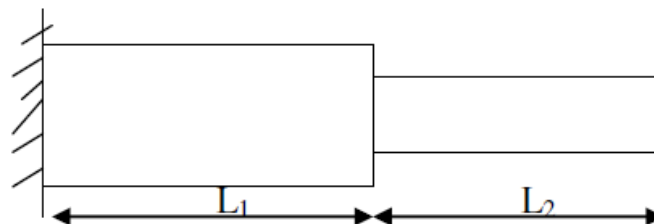

OR

- 10 Explain the evaluation of Eigen values and Eigen vectors for a beam with an example. [14M]

INDEX

S.No	Unit No	PageNos.
1	Unit – III	1-16
2	Unit – III	17-29
3	Unit – III	30-38
4	Unit – III	39-50
5	Unit – III	51-58

UNIT I

INTRODUCTION: The finite element analysis is a numerical technique. In this method all the complexities of the problems, like varying shape, boundary conditions and loads are maintained as they are but the solutions obtained are approximate. The fast improvements in computer hardware technology and slashing of cost of computers have boosted this method, since the computer is the basic need for the application of this method. A number of popular brand of finite element analysis packages are now available commercially. Some of the popular packages are STAAD-PRO, GT-STRUDEL, NASTRAN, NISA and ANSYS. Using these packages one can analyze several complex structures.

The finite element analysis originated as a method of stress analysis in the design of aircrafts. It started as an extension of matrix method of structural analysis. Today this method is used not only for the analysis in solid mechanics, but even in the analysis of fluid flow, heat transfer, electric and magnetic fields and many others. Civil engineers use this method extensively for the analysis of beams, space frames, plates, shells, folded plates, foundations, rock mechanics problems and seepage analysis of fluid through porous media. Both static and dynamic problems can be handled by finite element analysis. This method is used extensively for the analysis and design of ships, aircrafts, space crafts, electric motors and heat engines.

The **basic unknowns** or the **Field variables** which are encountered in the engineering problems are displacements in solid mechanics, velocities in fluid mechanics, electric and magnetic potentials in electrical engineering and temperatures in heat flow problems. In a continuum, these unknowns are infinite. The finite element procedure reduces such unknowns to a finite number by dividing the solution region into small parts called **elements** and by expressing the unknown field variables in terms of assumed **approximating functions** (Interpolating functions/Shape functions) within each element. The approximating functions are defined in terms of field variables of specified points called **nodes** or **nodal points**. Thus in the finite element analysis the unknowns are the field variables of the nodal points. Once these are found the field variables at any point can be found by using interpolation functions. After selecting elements and nodal unknowns next step in finite element analysis is to assemble **element properties** for each element. For example, in solid mechanics, we have to find the force-displacement i.e. stiffness characteristics of each individual element. Mathematically this relationship is of the form

$$[k]_e \{\delta\}_e = \{F\}_e$$

where $[k]_e$ is element stiffness matrix, $\{\delta\}_e$ is nodal displacement vector of the element and $\{F\}_e$ is nodal force vector. The element of stiffness matrix k_{ij} represent the force in coordinate direction 'i' due to a unit displacement in coordinate direction 'j'. Four methods are available for formulating these element properties viz. direct approach, variational approach, weighted residual approach and energy balance approach. Any

one of these methods can be used for assembling element properties. In solid mechanics variational approach is commonly employed to assemble stiffness matrix and nodal force vector (consistent loads). Element properties are used to assemble global properties/structure properties to get system equations $[k]\{u\} = \{F\}$. Then the boundary conditions are imposed. The solution of these simultaneous equations gives the nodal unknowns. Using these nodal values additional calculations are made to get the required values e.g. stresses, strains, moments, etc. in solid mechanics problems.

Thus the various steps involved in the finite element analysis are:

- (i) Select suitable field variables and the elements.
- (ii) Discretise the continua.
- (iii) Select interpolation functions.
- (iv) Find the element properties.
- (v) Assemble element properties to get global properties.
- (vi) Impose the boundary conditions.
- (vii) Solve the system equations to get the nodal unknowns.
- (viii) Make the additional calculations to get the required values.

Methods of Engineering Analysis

There are three methods are adopted for analyzing the product

1. Experimental methods

2. Analytical methods

Numerical methods

Experimental methods

In these methods the actual products or their proto type models or atleast their material specimen are tested by using some equipments

Ex: UTM, Rockwell hardness tester

Analytical methods

These methods are theoretically analyzing methods. Only simple and regular shaped products like beams, shafts, plates can be analyzed by these methods

Numerical methods

For the products of complicated sizes and shapes with complicated material properties and boundary conditions getting solution using analytical methods is highly difficult. In such situation the numerical method can be employed

There are three numerical methods

i) Functional approximating methods

ii) **Finite element method**

iii) Finite difference method

Application of FEM

S.No	Area of Study	Analysing problem
1	Civil Engineering structures	Analysis of trusses, folded plates, shell roofs, bridges and prestressed concrete structures
2	Aircraft structures	Analysis of aircraft wings, fins, rockets, space craft and missile structures
3	Mechanical Design	Stress analysis of pressure vessels, pistons, composite materials, Linkages and gears
4	Heat Conduction	Temperature distribution in solida and fluids
5	Hydraulic and water resources Engineering	Analysis of potential flows, free surface flows, viscous flows, analysis of hydraulic structures and dams
6	Electrical Machines and Electromagnetic	Analysis of synchronous and induction machines eddy current and core losses in electric machines
7	Nuclear Engineering	Analysis of nuclear pressure vessels and containment structures
8	Geomechanics	Stress analysis in soils, dams, layered piles and machine foundations

Advantages and disadvantages of FEM

Advantages

Using FEM we are able to

- 1.model irregular shaped bodies quite easily
- 2.handle general load conditions without difficulty

3. model bodies composed of several different materials because the element equations are evaluated individually
4. handle unlimited numbers and kinds of boundary conditions
5. vary the size of the element to make it possible to use small elements
6. alter the finite element model easily and cheaply
7. include dynamic effects

Disadvantages

1. The finite element method is time consuming process
2. FEM cannot produce exact results as those of analytical methods

Equations of Equilibrium for 3D Body

Typical three dimensional element of size $dx \times dy \times dz$. Face $abcd$ may be called as negative face of x and the face $efgh$ as the positive face of x since the x value for face $abcd$ is less than that for the face $efgh$. Similarly the face $aehd$ is negative face of y and $bfgc$ is positive face of y . Negative and positive faces of z are $dhgc$ and $aefb$. The direct stresses σ and shearing stresses τ acting on the negative faces are shown in the Fig. with suitable subscript. It may be noted that the first subscript of shearing stress is the plane and the second subscript is the direction. Thus the τ_{xy} means shearing stress on the plane where x value is constant and y is the direction.

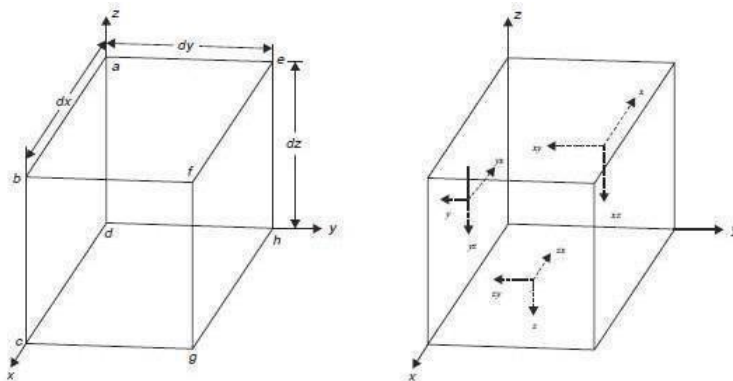

Face	Stress on -ve Face	Stresses on +ve Face
x	σ_x τ_{xy} τ_{xz}	$\sigma_x^+ = \sigma_x + \frac{\partial \sigma_x}{\partial x} dx$ $\tau_{xy}^+ = \tau_{xy} + \frac{\partial \tau_{xy}}{\partial x} dx$ $\tau_{xz}^+ = \tau_{xz} + \frac{\partial \tau_{xz}}{\partial x} dx$
y	σ_y τ_{yx} τ_{yz}	$\sigma_y^+ = \sigma_y + \frac{\partial \sigma_y}{\partial y} dy$ $\tau_{yx}^+ = \tau_{yx} + \frac{\partial \tau_{yx}}{\partial y} dy$ $\tau_{yz}^+ = \tau_{yz} + \frac{\partial \tau_{yz}}{\partial y} dy$
z	σ_z τ_{zx} τ_{zy}	$\sigma_z^+ = \sigma_z + \frac{\partial \sigma_z}{\partial z} dz$ $\tau_{zx}^+ = \tau_{zx} + \frac{\partial \tau_{zx}}{\partial z} dz$ $\tau_{zy}^+ = \tau_{zy} + \frac{\partial \tau_{zy}}{\partial z} dz$

Let the intensity of body forces acting on the element in x, y, z directions be X, Y and Z respectively as shown in Fig. The intensity of body forces are uniform over entire body. Hence the total body force in x, y, z direction on the element shown are given by

- (i) $X dx dy dz$ in x – direction
- (ii) $Y dx dy dz$ in y – direction and
- (iii) $Z dx dy dz$ in z – direction

Equations of Equilibrium

Considering all forces are acting we can write the equilibrium equations for the element

$$\sum F_x = 0$$

$$\sigma_x^+ dy dz - \sigma_x dy dz + \tau_{yx}^+ dx dz - \tau_{yx} dx dz + \tau_{zx}^+ dx dy - \tau_{zx} dx dy + X dx dy dz = 0$$

$$\text{i.e.} \quad \left(\sigma_x + \frac{\partial \sigma_x}{\partial x} dx \right) dy dz - \sigma_x dy dz + \left(\tau_{yx} + \frac{\partial \tau_{yx}}{\partial y} dy \right) dx dz - \tau_{yx} dx dz$$

$$+ \left(\tau_{zx} + \frac{\partial \tau_{zx}}{\partial z} dz \right) dx dy - \tau_{zx} dx dy + X dx dy dz = 0$$

Simplifying and dividing throughout by $dx dy dz$

$$\frac{\partial \sigma_x}{\partial x} + \frac{\partial \tau_{yx}}{\partial y} + \frac{\partial \tau_{zx}}{\partial z} + X = 0$$

Similarly $\Sigma F_y=0$ and $\Sigma F_z=0$ Equilibrium conditions give

$$\frac{\partial \tau_{xy}}{\partial x} + \frac{\partial \sigma_y}{\partial y} + \frac{\partial \tau_{yz}}{\partial z} + Y = 0$$

$$\frac{\partial \tau_{xz}}{\partial x} + \frac{\partial \tau_{yz}}{\partial y} + \frac{\partial \sigma_z}{\partial z} + Z = 0$$

$\Sigma M_x=0$

$$\tau_{yz}^+ dx dz \frac{dy}{2} + \tau_{yz}^- dx dz \frac{dy}{2} - \left[\tau_{xy}^+ dx dz \frac{dy}{2} + \tau_{xy}^- dx dz \frac{dy}{2} \right] = 0$$

$$\text{i.e.} \quad \left(\tau_{yz} + \frac{\partial \tau_{yz}}{\partial y} dy \right) dx dy \frac{dz}{2} + \tau_{yz} dx dy \frac{dz}{2} - \left[\left(\tau_{xy} + \frac{\partial \tau_{xy}}{\partial x} dx \right) dx dy \frac{dz}{2} + \tau_{xy} dx dy \frac{dz}{2} \right] = 0$$

Neglecting small quantity then

$$\tau_{zy} = \tau_{yz}$$

$\Sigma M_y=0$ then we will get

$$\tau_{xz} = \tau_{zx}$$

$\Sigma M_z=0$ then we will get

$$\tau_{xy} = \tau_{yx}$$

$$[\sigma]^T = [\sigma_x \sigma_y \sigma_z \tau_{xy} \tau_{yz} \tau_{xz}]$$

and the equilibrium equations are

$$\frac{\partial \sigma_x}{\partial x} + \frac{\partial \tau_{xy}}{\partial y} + \frac{\partial \tau_{xz}}{\partial z} + X = 0$$

$$\frac{\partial \tau_{xy}}{\partial x} + \frac{\partial \sigma_y}{\partial y} + \frac{\partial \tau_{yz}}{\partial z} + Y = 0$$

$$\frac{\partial \tau_{xz}}{\partial x} + \frac{\partial \tau_{yz}}{\partial y} + \frac{\partial \sigma_z}{\partial z} + Z = 0$$

$$\tau_{xy} = \tau_{yx}, \tau_{yz} = \tau_{zy} \text{ and } \tau_{xz} = \tau_{zx}$$

Strain Displacement equations

Taking displacement components in x, y, z directions as u, v, and w respectively, the relations among components of strain and the components of displacement are

$$\epsilon_x = \frac{\partial u}{\partial x} + \frac{1}{2} \left[\left(\frac{\partial u}{\partial x} \right)^2 + \left(\frac{\partial v}{\partial x} \right)^2 + \left(\frac{\partial w}{\partial x} \right)^2 \right]$$

$$\epsilon_y = \frac{\partial v}{\partial y} + \frac{1}{2} \left[\left(\frac{\partial u}{\partial y} \right)^2 + \left(\frac{\partial v}{\partial y} \right)^2 + \left(\frac{\partial w}{\partial y} \right)^2 \right]$$

$$\epsilon_z = \frac{\partial w}{\partial z} + \frac{1}{2} \left[\left(\frac{\partial u}{\partial z} \right)^2 + \left(\frac{\partial v}{\partial z} \right)^2 + \left(\frac{\partial w}{\partial z} \right)^2 \right]$$

$$\gamma_{xy} = \frac{\partial v}{\partial x} + \frac{\partial u}{\partial y} + \frac{\partial u}{\partial x} \cdot \frac{\partial u}{\partial y} + \frac{\partial v}{\partial x} \cdot \frac{\partial v}{\partial y} + \frac{\partial w}{\partial x} \cdot \frac{\partial w}{\partial y}$$

$$\gamma_{yz} = \frac{\partial w}{\partial y} + \frac{\partial v}{\partial z} + \frac{\partial u}{\partial y} \cdot \frac{\partial u}{\partial z} + \frac{\partial v}{\partial y} \cdot \frac{\partial v}{\partial z} + \frac{\partial w}{\partial y} \cdot \frac{\partial w}{\partial z}$$

$$\gamma_{xz} = \frac{\partial u}{\partial z} + \frac{\partial w}{\partial x} + \frac{\partial u}{\partial x} \cdot \frac{\partial u}{\partial z} + \frac{\partial v}{\partial x} \cdot \frac{\partial v}{\partial z} + \frac{\partial w}{\partial x} \cdot \frac{\partial w}{\partial z}$$

strains are expressed up to the accuracy of second order (quadratic) changes in displacements. These equations may be simplified to the first (linear) order accuracy only by dropping the second order changes terms. Then linear strain – displacement relation is given by:

$$\epsilon_x = \frac{\partial u}{\partial x} \quad \gamma_{xy} = \frac{\partial u}{\partial x} + \frac{\partial v}{\partial y}$$

$$\epsilon_y = \frac{\partial v}{\partial y} \quad \gamma_{yz} = \frac{\partial v}{\partial y} + \frac{\partial w}{\partial z}$$

$$\epsilon_z = \frac{\partial w}{\partial z} \quad \gamma_{xz} = \frac{\partial w}{\partial x} + \frac{\partial u}{\partial z}$$

LINEAR CONSTITUTIVE EQUATIONS

The constitutive law expresses the relationship among stresses and strains. In theory of elasticity, usually it is considered as linear. In one dimensional stress analysis, the linear constitutive law is stress is proportional to strain and the constant of proportionality is called Young's modulus. It is very well known as Hooke's law.

The similar relation is expressed among the six components of stresses and strains and is called '**Generalized Hooke's Law**'. This may be stated as:

$$\begin{Bmatrix} \sigma_x \\ \sigma_y \\ \sigma_z \\ \tau_{xy} \\ \tau_{yz} \\ \tau_{xz} \end{Bmatrix} = \begin{bmatrix} D_{11} & D_{12} & D_{13} & D_{14} & D_{15} & D_{16} \\ D_{21} & D_{22} & D_{23} & D_{24} & D_{25} & D_{26} \\ D_{31} & D_{32} & D_{33} & D_{34} & D_{35} & D_{36} \\ D_{41} & D_{42} & D_{43} & D_{44} & D_{45} & D_{46} \\ D_{51} & D_{52} & D_{53} & D_{54} & D_{55} & D_{56} \\ D_{61} & D_{62} & D_{63} & D_{64} & D_{65} & D_{66} \end{bmatrix} \begin{Bmatrix} \epsilon_x \\ \epsilon_y \\ \epsilon_z \\ \gamma_{xy} \\ \gamma_{yz} \\ \gamma_{xz} \end{Bmatrix}$$

$$\{\sigma\} = [D] \{\epsilon\},$$

where D is 6×6 matrix of constants of elasticity to be determined by experimental investigations for each material. As D is symmetric matrix [$D_{ij} = D_{ji}$], there are 21 material properties for linear elastic **Anisotropic Materials**. Certain materials exhibit symmetry with respect to planes within the body. Such materials are called **Orthotropic materials**. Hence for orthotropic materials, the number of material constants reduces to 9 as shown below:

$$\begin{Bmatrix} \sigma_x \\ \sigma_y \\ \sigma_z \\ \tau_{xy} \\ \tau_{yz} \\ \tau_{xz} \end{Bmatrix} = \begin{bmatrix} D_{11} & D_{12} & D_{13} & 0 & 0 & 0 \\ & D_{22} & D_{23} & 0 & 0 & 0 \\ & & D_{33} & 0 & 0 & 0 \\ & Sym & & D_{44} & 0 & 0 \\ & & & & D_{55} & 0 \\ & & & & & D_{66} \end{bmatrix} \begin{Bmatrix} \epsilon_x \\ \epsilon_y \\ \epsilon_z \\ \gamma_{xy} \\ \gamma_{yz} \\ \gamma_{xz} \end{Bmatrix}$$

Using the Young's Moduli and Poisons ratio terms the above relation may be expressed as:

$$\begin{aligned} \epsilon_x &= \frac{\sigma_x}{E_x} - \mu_{yx} \frac{\sigma_y}{E_y} - \mu_{zx} \frac{\sigma_z}{E_z} \\ \epsilon_y &= -\mu_{xy} \frac{\sigma_x}{E_x} + \frac{\sigma_y}{E_y} - \mu_{zy} \frac{\sigma_z}{E_z} \\ \epsilon_z &= -\mu_{xz} \frac{\sigma_x}{E_x} - \mu_{yz} \frac{\sigma_y}{E_y} + \frac{\sigma_z}{E_z} \\ \gamma_{xy} &= \frac{\tau_{xy}}{G_{xy}}, \quad \gamma_{yz} = \frac{\tau_{yz}}{G_{yz}}, \quad \gamma_{zx} = \frac{\tau_{zx}}{G_{zx}} \end{aligned}$$

Note that there are 12 material properties in above equations However only nine of these are independent because the following relations exist

$$\frac{E_x}{\mu_{xy}} = \frac{E_y}{\mu_{yx}}, \quad \frac{E_y}{\mu_{yz}} = \frac{E_z}{\mu_{zy}}, \quad \frac{E_z}{\mu_{zx}} = \frac{E_x}{\mu_{xz}}$$

For **Isotropic Materials** the above set of equations are further simplified. An isotropic material is the one that has same material property in all directions. In other word for isotropic materials,

$$E_x = E_y = E_z \text{ say } E \text{ and}$$

$$\mu_{xy} = \mu_{yx} = \mu_{yz} = \mu_{zy} = \mu_{xz} = \mu_{zx} \text{ say } \mu$$

Hence for a three dimensional problem, the strain stress relation for isotropic material is,

$$\begin{pmatrix} \epsilon_x \\ \epsilon_y \\ \epsilon_z \\ \gamma_{xy} \\ \gamma_{yz} \\ \gamma_{xz} \end{pmatrix} = \begin{pmatrix} \frac{1}{E} & -\frac{\mu}{E} & -\frac{\mu}{E} & 0 & 0 & 0 \\ -\frac{\mu}{E} & \frac{1}{E} & -\frac{\mu}{E} & 0 & 0 & 0 \\ -\frac{\mu}{E} & -\frac{\mu}{E} & \frac{1}{E} & 0 & 0 & 0 \\ 0 & 0 & 0 & \frac{1-\mu}{2} & 0 & 0 \\ 0 & 0 & 0 & 0 & \frac{1-\mu}{2} & 0 \\ 0 & 0 & 0 & 0 & 0 & \frac{1-\mu}{2} \end{pmatrix} \begin{pmatrix} \sigma_x \\ \sigma_y \\ \sigma_z \\ \tau_{xy} \\ \tau_{yz} \\ \tau_{xz} \end{pmatrix}$$

Since $G = \frac{E}{2(1-\mu)}$ and stress – strain relation is

$$\begin{pmatrix} \sigma_x \\ \sigma_y \\ \sigma_z \\ \tau_{xy} \\ \tau_{yz} \\ \tau_{xz} \end{pmatrix} = \frac{E}{(1+\mu)(1-2\mu)} \begin{pmatrix} 1-\mu & \mu & \mu & 0 & 0 & 0 \\ \mu & 1-\mu & \mu & 0 & 0 & 0 \\ \mu & \mu & 1-\mu & 0 & 0 & 0 \\ 0 & 0 & 0 & \frac{1-2\mu}{2} & 0 & 0 \\ 0 & 0 & 0 & 0 & \frac{1-2\mu}{2} & 0 \\ 0 & 0 & 0 & 0 & 0 & \frac{1-2\mu}{2} \end{pmatrix} \begin{pmatrix} \epsilon_x \\ \epsilon_y \\ \epsilon_z \\ \gamma_{xy} \\ \gamma_{yz} \\ \gamma_{xz} \end{pmatrix}$$

PLANE STRESS PROBLEM

The thin plates subject to forces in their plane only, fall under this category of the problems. Fig. shows a typical plane stress problem. In this, there is

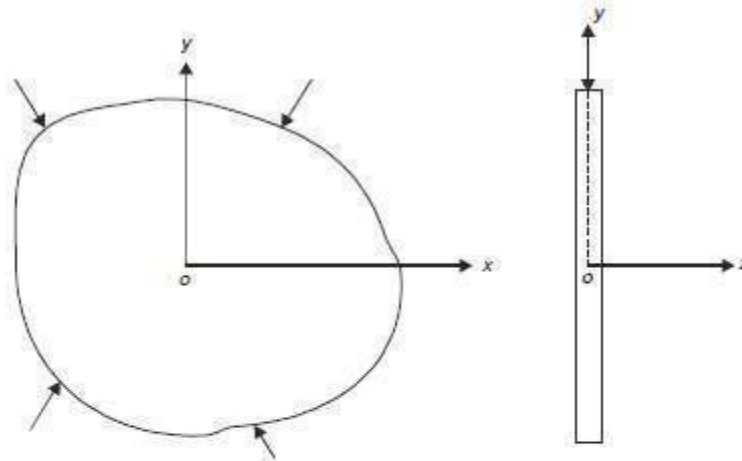

no force in the z-direction and no variation of any forces in z-direction. Hence

$$\sigma_z = \tau_{xz} = \tau_{yz} = 0$$

The conditions $\tau_{xz} = \tau_{yz} = 0$ give $\gamma_{xz} = \gamma_{yz} = 0$ and the condition $\sigma_z = 0$ gives,

$$\sigma_z = \mu \varepsilon_x + \mu \varepsilon_y + (1 - \mu) \varepsilon_z = 0$$

i.e.
$$\varepsilon_z = -\frac{\mu}{1 - \mu} (\varepsilon_x + \varepsilon_y)$$

If this is substituted in equation 2.13 the constitutive law reduces to

$$\begin{Bmatrix} \sigma_x \\ \sigma_y \\ \tau_{xy} \end{Bmatrix} = \frac{E}{1 - \mu^2} \begin{bmatrix} 1 & \mu & 0 \\ \mu & 1 & 0 \\ 0 & 0 & \frac{1 - \mu}{2} \end{bmatrix} \begin{Bmatrix} \varepsilon_x \\ \varepsilon_y \\ \gamma_{xy} \end{Bmatrix}$$

PLANE STRAIN PROBLEM

A long body subject to significant lateral forces but very little longitudinal forces falls under this category of problems. Examples of such problems are pipes, long strip footings, retaining walls, gravity dams, tunnels, etc. In these problems, except for a small distance at the ends, state of stress is represented by any small longitudinal strip. The displacement in longitudinal direction (z -direction) is zero in typical strip. Hence the strain components,

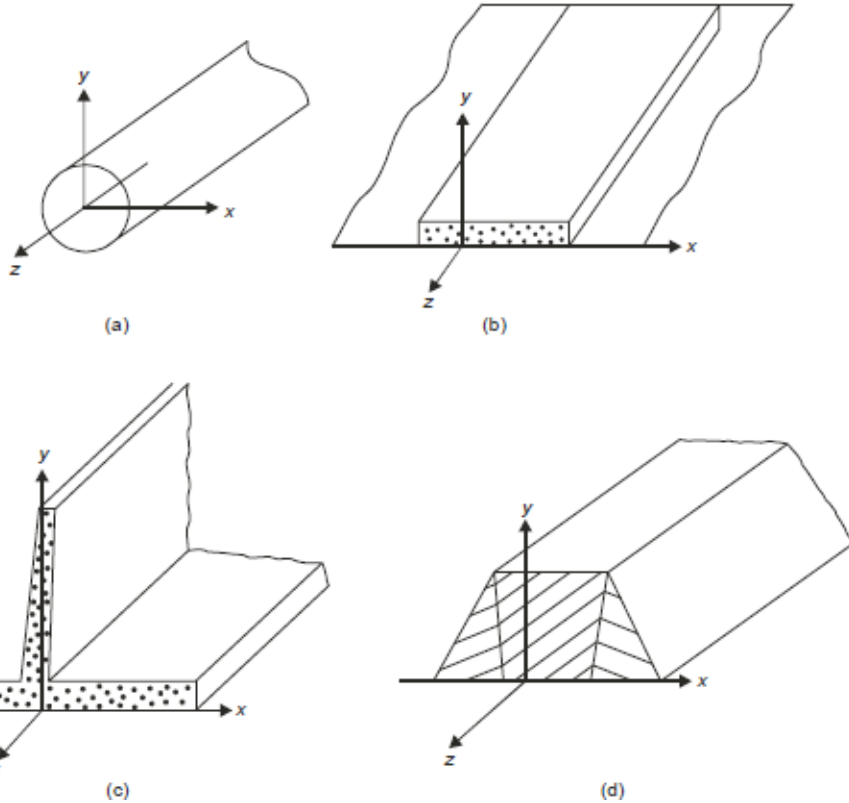

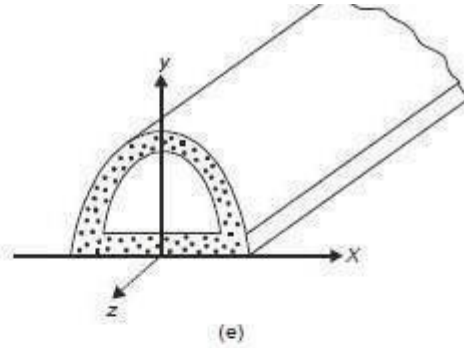

Fig. 2.7 (contd)

$$\epsilon_z = \gamma_{xz} = \gamma_{yz} = 0$$

$\gamma_{xz} = \gamma_{yz} = 0$ means τ_{xz} and τ_{yz} are zero.

$\epsilon_z = 0$ means

$$\epsilon_z = \frac{\sigma_z}{E} - \mu \frac{(\sigma_x + \sigma_y)}{E} = 0$$

i.e.

$$\sigma_z = \mu(\sigma_x + \sigma_y)$$

Hence equation 2.13 when applied to plane strains problems reduces to

$$\begin{Bmatrix} \sigma_x \\ \sigma_y \\ \tau_{xy} \end{Bmatrix} = \frac{E}{(1+\mu)(1-2\mu)} \begin{pmatrix} 1-\mu & \mu & 0 \\ \mu & 1-\mu & 0 \\ 0 & 0 & \frac{1-2\mu}{2} \end{pmatrix} \begin{Bmatrix} \epsilon_x \\ \epsilon_y \\ \gamma_{xy} \end{Bmatrix}$$

Functional Approximation Methods

The nature of the problems for which the solutions to be found out are

- i) Equilibrium problems
- ii) Eigen value problems
- iii) propagation problems

The functional approximation methods for solving the above types of problems are classified in to major types

- i) Variational methods
- ii) Weighted residual methods

Rayleigh-Ritz method is good example for variational method

Weighted residual method

- Point collocation method
- sub domain collocation method
- Least square method
- Galerkin's method

Rayleigh-Ritz Method

Rayleigh -Ritz method is a typical variational method in which principle of integral approach is adopted for solving the complex structural problems

i) Minimum potential energy method

ii) Integral approach method

Minimum potential energy method

In this method the total potential energy ' Π ' is considered as the function of generalized coordinated which are exactly equal to the number of degrees of freedom

$$\Pi = U - W$$

U=Internal energy

W=work done by the external force

Polynomial series

$$y(x) = a_1 + a_2x + a_3x^2 + \text{-----}$$

a_1, a_2, a_3 ----- are Ritz parameters

Integral approach method

Differential equation is

$$D \frac{d^2y}{dx^2} + Q = 0$$

$$\int [D/2(dy/dx) - Qy] dx$$

ONE DIMENSIONAL PROBLEMS

Bar and beam elements are considered as One Dimensional elements. These elements are often used to model trusses and frame structures

Types of Loading

i) Body force (f)

It is distributed force acting on every elemental volume of the body. Unit is Force / Unit volume. Ex: Self weight due to gravity.

ii) Traction (T)

It is distributed force acting on the surface of the body. Unit is Force / Unit area. But for one dimensional problem, unit is Force / Unit length. Ex: Frictional resistance, viscous drag and Surface shear.

iii) Point load (P)

It is force acting at a particular point which causes displacement.

Finite Element Modeling

It has two processes. (1) Discretization of structure (2) Numbering of nodes.

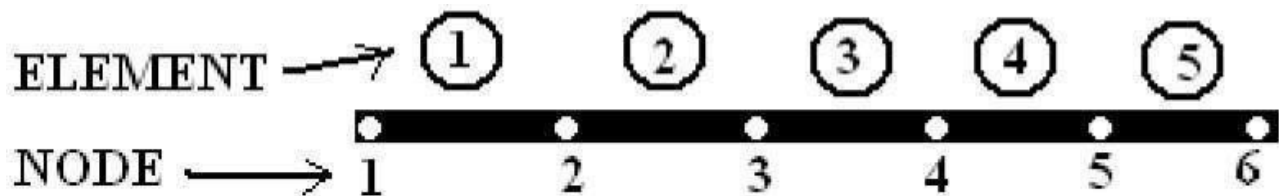

CO – ORDINATES

(A) Global co – ordinates, (B) Local co – ordinates and (C) Natural co – ordinates.

- Equation of Stiffness Matrix for One dimensional bar element

$$[K] = \frac{AE}{l} \begin{bmatrix} 1 & -1 \\ -1 & 1 \end{bmatrix}$$

For a stepped bar loaded as shown in figure. Determine a) Nodal displacements

b) support Reactions c)Element Stress

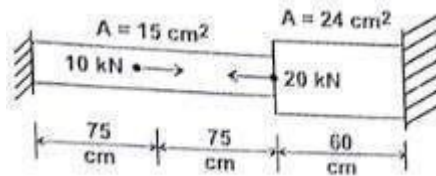

Solution

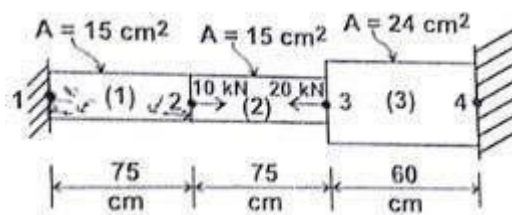

Element 1	Element 2	Element 3
$A_1 = 15 \text{ cm}^2$	$A_2 = 15 \text{ cm}^2$	$A_3 = 24 \text{ cm}^2$
$E_1 = 20 \times 10^6 \text{ N/cm}^2$	$E_2 = 20 \times 10^6 \text{ N/cm}^2$	$E_3 = 20 \times 10^6 \text{ N/cm}^2$
$L_1 = 75 \text{ cm}$	$L_2 = 75 \text{ cm}$	$L_3 = 60 \text{ cm}$
$\alpha_1 = 11 \times 10^{-6} \text{ cm/cm}^0\text{C}$	$\alpha_2 = 11 \times 10^{-6} \text{ cm/cm}^0\text{C}$	$\alpha_3 = 11 \times 10^{-6} \text{ cm/cm}^0\text{C}$
$\Delta T = 10^0\text{C}$	$\Delta T = 10^0\text{C}$	$\Delta T = 10^0\text{C}$

$$F_{0(1)} = A_1 E_1 \alpha_1 \Delta T = 33000 \text{ N}$$

$$F_{0(2)} = A_2 E_2 \alpha_2 \Delta T = 33000 \text{ N}$$

$$F_{0(3)} = A_3 E_3 \alpha_3 \Delta T = 52800 \text{ N}$$

The Nodal Forces are

$$F_1 = R_1 + P - F_{0(1)} = R_1 - 33000$$

$$F_2 = P_2 + F_{0(1)} - F_{0(2)} = 10000$$

$$F_3 = P_3 + F_{0(2)} - F_{0(3)} = -39800$$

$$F_4 = R_4 + P_3 + F_{0(2)} - F_{0(3)} = R_4 + 52800$$

The stiffness values are

$$k_1 = A_1 E_1 / L_1 = 4 \times 10^6 \text{ N/cm}$$

$$k_2 = A_2 E_2 / L_2 = 4 \times 10^6 \text{ N/cm}$$

$$k_3 = A_3 E_3 / L_3 = 8 \times 10^6 \text{ N/cm}$$

the nodal conditions are $u_1 = 0$ and $u_4 = 0$

$$10^6 \begin{bmatrix} 4 & -4 & 0 & 0 \\ -4 & 8 & -4 & 0 \\ 0 & -4 & 12 & -8 \\ 0 & 0 & -8 & 8 \end{bmatrix} \begin{Bmatrix} 0 \\ u_2 \\ u_3 \\ 0 \end{Bmatrix} = \begin{Bmatrix} R_1 - 33,000 \\ 10,000 \\ -39,800 \\ R_4 + 52,800 \end{Bmatrix}$$

solve the above matrix then you will get the values of u_2 and u_3 as $-3.48 \times 10^{-3} \text{ cm}$ and as $-0.49 \times 10^{-1} \text{ cm}$

$$R_1 = 34960 \text{ N}$$

$$R_4 = -24960 \text{ N}$$

$$\sigma_{r(1)} = \sigma_{(1)} - \sigma_{\square}^2$$

$$\sigma_{(1)} = -2330.7 \text{ N/cm}$$

$$\sigma_{r(2)} = \sigma_{(2)} - \sigma_{\square}^2$$

$$\sigma_{(2)} = -2997.3 \text{ N/cm}$$

$$\sigma_{r(3)} = \sigma_{(3)} - \sigma_{\square}^2$$

$$\sigma_{(3)} = -1010 \text{ N/cm}$$

UNIT II

Two Dimensional Trusses

Figure shows a typical plane truss. The truss may be statically determinate or indeterminate. In the analysis all joints are assumed pin connected and all loads act at joints only. These assumptions result into no bending of any member. All members are subjected to only direct stresses—tensile or compressive. Now we are interested to see the finite element analysis procedure for such trusses

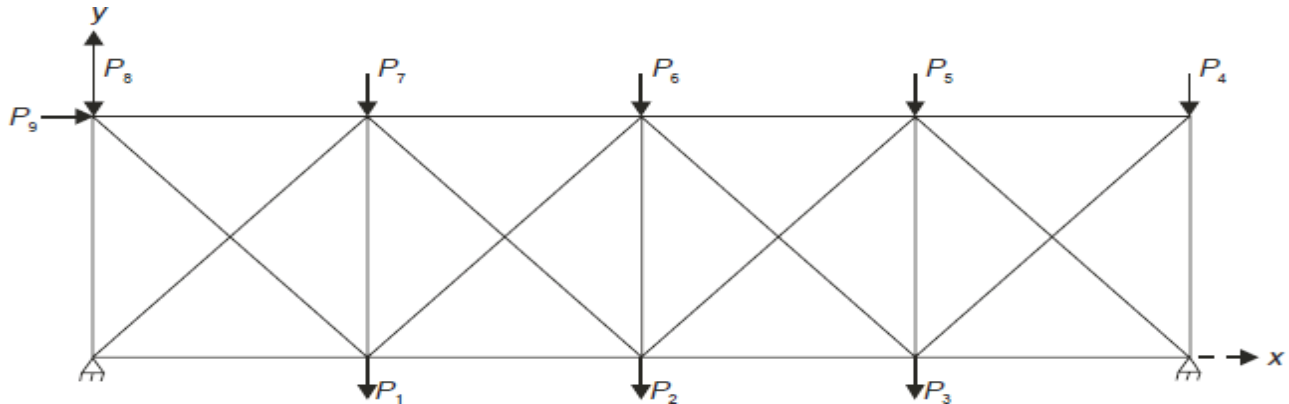

Step 1: Field Variables and Elements

Joint displacements are selected as basic field variables. Since there is no bending of the members, we have to ensure only displacement continuity (Co-continuity) and there is no need to worry about slope continuity (C1continuity). Hence we select two noded bar elements for the analysis of trusses. Since the members are subjected to only axial forces, the displacements are only in the axial directions of the members. Therefore the nodal variable vector for the typical bar element shown in Fig

$$\{\delta'\} = \begin{Bmatrix} \delta'_1 \\ \delta'_2 \end{Bmatrix}$$

where δ'_1, δ'_2 are in the axial directions of the element. But the axial direction is not same for all members. If we select x - y as global coordinate system, there are two displacement components at every node. Hence the nodal variable vector for a typical element is,

$$\{\delta\}^T = [\delta_1 \quad \delta_2 \quad \delta_3 \quad \delta_4]$$

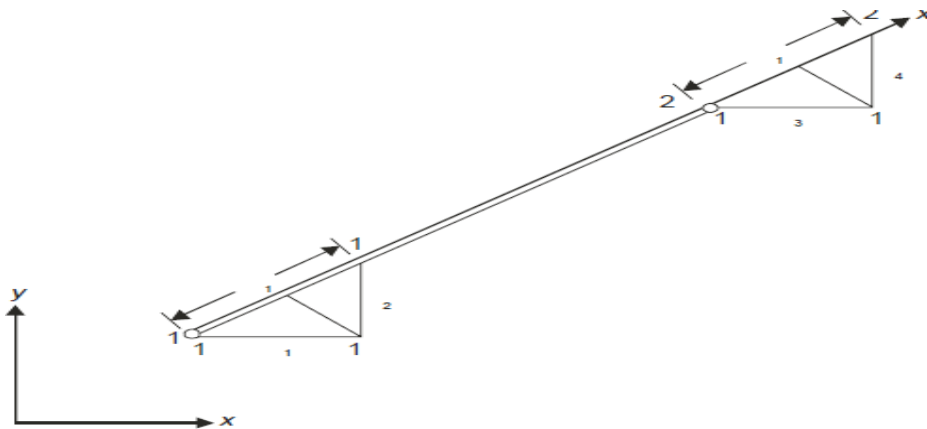

From the Figure it is clear that

$$\delta'_1 = \delta_1 \cos\theta + \delta_2 \sin\theta$$

$$\delta'_2 = \delta_3 \cos\theta + \delta_4 \sin\theta$$

If l and m are the direction cosines,

$$l = \cos\theta, m = \sin\theta,$$

$$\therefore \delta'_1 = l\delta_1 + m\delta_2$$

$$\delta'_2 = l\delta_3 + m\delta_4$$

i.e.
$$\{\delta'\} = \begin{Bmatrix} \delta'_1 \\ \delta'_2 \end{Bmatrix} = \begin{bmatrix} l & m & 0 & 0 \\ 0 & 0 & l & m \end{bmatrix} \begin{Bmatrix} \delta_1 \\ \delta_2 \\ \delta_3 \\ \delta_4 \end{Bmatrix}$$

i.e.
$$\{\delta'\} = [L]\{\delta\}$$

where
$$[L] = \begin{bmatrix} l & m & 0 & 0 \\ 0 & 0 & l & m \end{bmatrix}$$

and $[L]$ is called transformation (or rotation) matrix. If the coordinates (x_1, y_1) and (x_2, y_2) of node 1 and 2 of the elements are known, we can find

$$l = \frac{x_2 - x_1}{l_e}, m = \frac{y_2 - y_1}{l_e}$$

where
$$l_e = \sqrt{(x_2 - x_1)^2 + (y_2 - y_1)^2}$$

Step 2: Discretising

A member may be taken as an element conveniently. Hence in the typical truss considered. There are

- (a) 4 – top chord members
- (b) 4 – bottom chord members
- (c) 5 – vertical members and
- (d) 8 – diagonal members

\therefore Total elements selected are –21

There are 10 nodal points and they are numbered as shown in Fig.

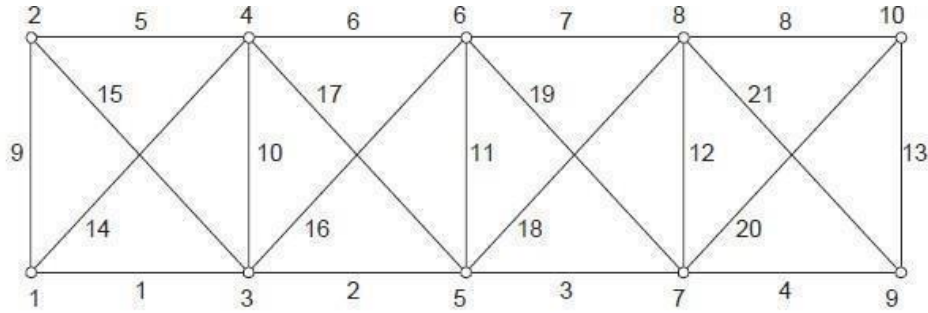

Fig. Numbering nodes and members

The numbering is such that the band width is minimum. In this case maximum difference in the node numbers of an element is in diagonal members and is equal to 3. The degree of freedom of each node is 2, one in x-direction and another in y-direction. Hence the maximum band width

$$= (3 + 1) \times 2 = 8$$

Total degrees of freedom is

$$\begin{aligned} &= \text{Total number of nodes} \times \text{degree of freedom of each node} \\ &= 10 \times 2 = 20 \end{aligned}$$

Step 3: Interpolation Functions

Since bar element is used,

$$\{u\} = [N]\{\delta'\}$$

where

$$[N] = [N_1 \ N_2] = \left[\frac{x'_2 - x'}{l} \quad \frac{x' - x'_1}{l} \right] = \left[\frac{1 - \xi'}{2} \quad \frac{1 + \xi'}{2} \right]$$

Step 4: Element Properties

(a) Stiffness Matrix: In the analysis of bars and columns, we have seen the element stiffness matrix is

$$[k]_e = \frac{EA}{l} \begin{bmatrix} 1 & -1 \\ -1 & 1 \end{bmatrix}$$

when viewed in local coordinate system, the truss is also a one dimensional two noded bar element. Hence the element stiffness matrix of truss element in local coordinate system, $[k']_e$ is given by

$$\begin{aligned} [k']_e &= \frac{EA}{l_e} \begin{bmatrix} 1 & -1 \\ -1 & 1 \end{bmatrix} \\ \therefore U_e &= \frac{1}{2} \{\delta'\}^T [k'] \{\delta'\} \\ \{\delta'\} &= [L] \{\delta\} \end{aligned}$$

$$\begin{aligned}\therefore U_e &= \frac{1}{2} ([L]\{\delta\})^T [k'] [L]\{\delta\} \\ &= \frac{1}{2} \{\delta\}^T [L]^T [k'] [L]\{\delta\} = \frac{1}{2} \{\delta\}^T [k_e]\{\delta\}\end{aligned}$$

where $[k]_e = [L]^T [k'] [L]$

and it may be called as element stiffness matrix in global coordinate system.

$$\therefore [k]_e = \begin{bmatrix} l & 0 \\ m & 0 \\ 0 & l \\ 0 & m \end{bmatrix} \frac{E_e A_e}{l_e} \begin{bmatrix} 1 & -1 \\ -1 & 1 \end{bmatrix} \begin{bmatrix} l & m & 0 & 0 \\ 0 & 0 & l & m \end{bmatrix}$$

$$= \frac{E_e A_e}{l_e} \begin{bmatrix} l & 0 \\ m & 0 \\ 0 & l \\ 0 & m \end{bmatrix} \begin{bmatrix} l & m & -l & -m \\ -l & -m & l & m \end{bmatrix} = \frac{E_e A_e}{l_e} \begin{bmatrix} l^2 & lm & -l^2 & -lm \\ lm & m^2 & -lm & -m^2 \\ -l^2 & -lm & l^2 & lm \\ -lm & -m^2 & lm & m^2 \end{bmatrix}$$

Step 6: Boundary Conditions

If hand calculations are made usually elimination approach is used and if computers are used penalty approach is used for imposing boundary conditions. The method is exactly same as explained in the analysis of columns and tension members.

Step 7: Solution of Simultaneous Equations

This step is also same as explained in the analysis of tension bars and columns.

Step 8: Additional Calculations

Analysts are interested in finding stresses and forces in the members of the truss.

Finite Elements for 2-D Problems

General Formula for the Stiffness Matrix

Displacements (u, v) in a plane element are interpolated from nodal displacements (u_i, v_i) using shape functions N_i as follows,

$$\begin{Bmatrix} u \\ v \end{Bmatrix} = \begin{bmatrix} N_1 & 0 & N_2 & 0 & \dots \\ 0 & N_1 & 0 & N_2 & \dots \end{bmatrix} \begin{Bmatrix} u_1 \\ v_1 \\ u_2 \\ v_2 \\ \vdots \end{Bmatrix} \quad \text{or} \quad \mathbf{u} = \mathbf{N}\mathbf{d}$$

where N is the shape function matrix, u the displacement vector and d the nodal displacement vector. Here we have assumed that u depends on the nodal values of u only, and v on nodal values of v only. Most commonly employed 2-D elements are linear or quadratic triangles and quadrilaterals.

Constant Strain Triangle (CST or T3)

This is the simplest 2-D element, which is also called *linear triangular element*.

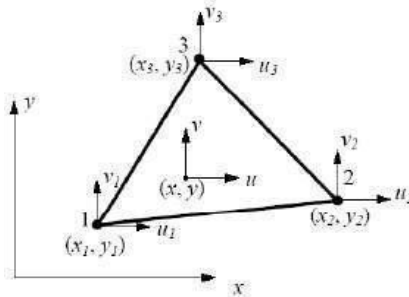

For this element, we have three nodes at the vertices of the triangle, which are numbered around the element in the counter clockwise direction. Each node has two degrees of freedom (can move in the *x* and *y* directions). The displacements *u* and *v* are assumed to be linear functions within the element, that is,

$$u = b_1 + b_2x + b_3y, \quad v = b_4 + b_5x + b_6y$$

Where $b_i (i = 1, 2, \dots, 6)$ are constants. From these, the strains are found to be,

$$\varepsilon_x = b_2, \quad \varepsilon_y = b_6, \quad \gamma_{xy} = b_3 + b_5$$

which are constant throughout the element.

The shape functions (linear functions in x and y) are

$$N_1 = \frac{1}{2A} \{(x_2 y_3 - x_3 y_2) + (y_2 - y_3)x + (x_3 - x_2)y\}$$

$$N_2 = \frac{1}{2A} \{(x_3 y_1 - x_1 y_3) + (y_3 - y_1)x + (x_1 - x_3)y\}$$

$$N_3 = \frac{1}{2A} \{(x_1 y_2 - x_2 y_1) + (y_1 - y_2)x + (x_2 - x_1)y\}$$

and

$$A = \frac{1}{2} \det \begin{bmatrix} 1 & x_1 & y_1 \\ 1 & x_2 & y_2 \\ 1 & x_3 & y_3 \end{bmatrix} \quad \text{is the area of the triangle.}$$

The displacements should satisfy the following six equations,

$$u_1 = b_1 + b_2 x_1 + b_3 y_1$$

$$u_2 = b_1 + b_2 x_2 + b_3 y_2$$

$$\vdots$$

$$v_3 = b_4 + b_5 x_3 + b_6 y_3$$

Solving these equations, we can find the coefficients b_1, b_2, \dots , and b_6 in terms of nodal displacements and coordinates.

The displacements can be expressed as

$$\begin{Bmatrix} u \\ v \end{Bmatrix} = \begin{bmatrix} N_1 & 0 & N_2 & 0 & N_3 & 0 \\ 0 & N_1 & 0 & N_2 & 0 & N_3 \end{bmatrix} \begin{Bmatrix} u_1 \\ v_1 \\ u_2 \\ v_2 \\ u_3 \\ v_3 \end{Bmatrix}$$

The strain-displacement relations are written as

$$\begin{Bmatrix} \epsilon_x \\ \epsilon_y \\ \gamma_{xy} \end{Bmatrix} = \mathbf{B}\mathbf{d} = \frac{1}{2A} \begin{bmatrix} y_{23} & 0 & y_{31} & 0 & y_{12} & 0 \\ 0 & x_{32} & 0 & x_{13} & 0 & x_{21} \\ x_{32} & y_{23} & x_{13} & y_{31} & x_{21} & y_{12} \end{bmatrix} \begin{Bmatrix} u_1 \\ v_1 \\ u_2 \\ v_2 \\ u_3 \\ v_3 \end{Bmatrix}$$

where $x_{ij} = x_i - x_j$ and $y_{ij} = y_i - y_j$ ($i, j = 1, 2, 3$). Again, we see constant strains within the element. From stress-strain relation, we see that stresses obtained using the CST element are also constant.

The element stiffness matrix for the CST element,

$$\mathbf{k} = \int_V \mathbf{B}^T \mathbf{E} \mathbf{B} dV = tA(\mathbf{B}^T \mathbf{E} \mathbf{B})$$

in which t is the thickness of the element. Notice that \mathbf{k} for CST is a 6 by 6 symmetric matrix.

The Natural Coordinates

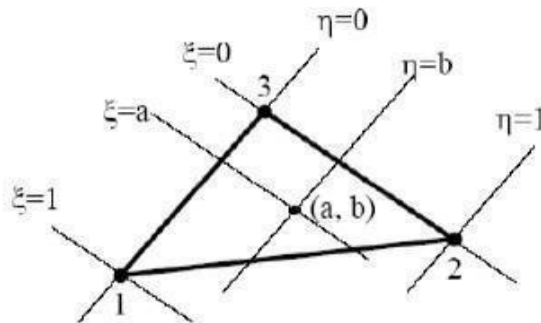

We introduce the natural coordinates (ξ, η) on the triangle, then the shape functions can be represented simply by,

$$N_1 = \xi, \quad N_2 = \eta, \quad N_3 = 1 - \xi - \eta$$

Notice that,

$$N_1 + N_2 + N_3 = 1$$

which ensures that the rigid body translation is represented by the chosen shape functions. Also, as in the 1-D case,

$$N_i = \begin{cases} 1, & \text{at node } i; \\ 0, & \text{at the other nodes} \end{cases}$$

and varies linearly within the element.

The plot for shape function N_1 is shown in the following figure. N_2 and N_3 have similar features.

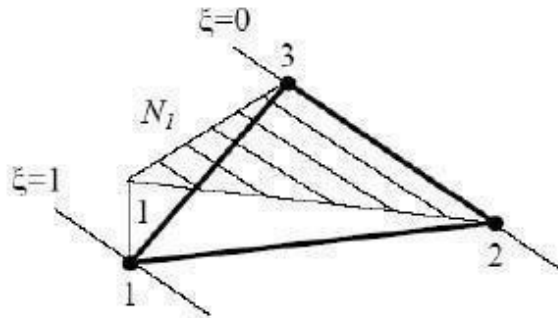

We have two coordinate systems for the element: the global coordinates (x, y) and the natural coordinates (ξ, η) . The relation between the two is given by

$$\begin{aligned} x &= N_1 x_1 + N_2 x_2 + N_3 x_3 & \longrightarrow & \quad x = x_{13} \xi + x_{23} \eta + x_3 \\ y &= N_1 y_1 + N_2 y_2 + N_3 y_3 & & \quad y = y_{13} \xi + y_{23} \eta + y_3 \end{aligned}$$

where $x_{ij} = x_i - x_j$ and $y_{ij} = y_i - y_j$ ($i, j = 1, 2, 3$) as defined earlier.

Displacement u or v on the element can be viewed as functions of (x, y) or (ξ, η) .

Using the chain rule for derivatives, we have,

$$\begin{Bmatrix} \frac{\partial u}{\partial \xi} \\ \frac{\partial u}{\partial \eta} \end{Bmatrix} = \begin{bmatrix} \frac{\partial x}{\partial \xi} & \frac{\partial y}{\partial \xi} \\ \frac{\partial x}{\partial \eta} & \frac{\partial y}{\partial \eta} \end{bmatrix} \begin{Bmatrix} \frac{\partial u}{\partial x} \\ \frac{\partial u}{\partial y} \end{Bmatrix} = \mathbf{J} \begin{Bmatrix} \frac{\partial u}{\partial x} \\ \frac{\partial u}{\partial y} \end{Bmatrix}$$

where \mathbf{J} is called the *Jacobian matrix* of the transformation, and is expressed as

$$\mathbf{J} = \begin{bmatrix} x_{13} & y_{13} \\ x_{23} & y_{23} \end{bmatrix}, \quad \mathbf{J}^{-1} = \frac{1}{2A} \begin{bmatrix} y_{23} & -y_{13} \\ -x_{23} & x_{13} \end{bmatrix}$$

where $\det \mathbf{J} = x_{13} y_{23} - x_{23} y_{13} = 2A$ and A is the area of the triangular element.

$$\begin{Bmatrix} \frac{\partial u}{\partial x} \\ \frac{\partial u}{\partial y} \end{Bmatrix} = \frac{1}{2A} \begin{bmatrix} y_{23} & -y_{13} \\ -x_{23} & x_{13} \end{bmatrix} \begin{Bmatrix} \frac{\partial u}{\partial \xi} \\ \frac{\partial u}{\partial \eta} \end{Bmatrix} = \frac{1}{2A} \begin{bmatrix} y_{23} & -y_{13} \\ -x_{23} & x_{13} \end{bmatrix} \begin{Bmatrix} u_1 - u_3 \\ u_2 - u_3 \end{Bmatrix}$$

Similarly,

$$\begin{Bmatrix} \frac{\partial v}{\partial x} \\ \frac{\partial v}{\partial y} \end{Bmatrix} = \frac{1}{2A} \begin{bmatrix} y_{23} & -y_{13} \\ -x_{23} & x_{13} \end{bmatrix} \begin{Bmatrix} v_1 - v_3 \\ v_2 - v_3 \end{Bmatrix}$$

Using the relations $\boldsymbol{\varepsilon} = \mathbf{D}\mathbf{u} = \mathbf{D}\mathbf{N}\mathbf{d} = \mathbf{B}\mathbf{d}$, we obtain the strain-displacement matrix,

$$\mathbf{B} = \frac{1}{2A} \begin{bmatrix} y_{23} & 0 & y_{31} & 0 & y_{12} & 0 \\ 0 & x_{32} & 0 & x_{13} & 0 & x_{21} \\ x_{32} & y_{23} & x_{13} & y_{31} & x_{21} & y_{12} \end{bmatrix}$$

Applications of the CST Element:

- Use in areas where the strain gradient is small.
- Use in mesh transition areas (fine mesh to coarse mesh).
- Avoid using CST in stress concentration or other crucial areas in the structure, such as edges of holes and corners.
- Recommended for quick and preliminary FE analysis of 2-D problems.

Linear Strain Triangle (LST or T6)

This element is also called *quadratic triangular element*.

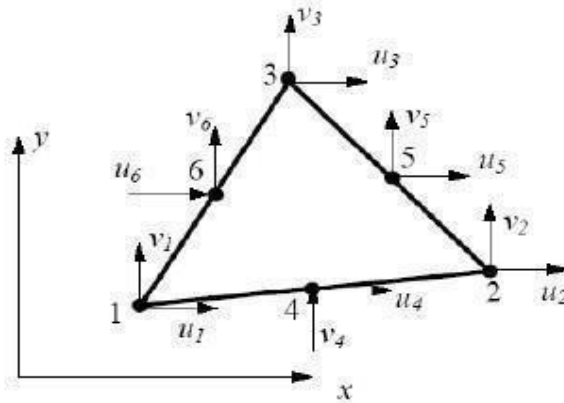

There are six nodes on this element: three corner nodes and three mid-side nodes. Each node has two degrees of freedom (DOF) as before. The displacements (u, v) are assumed to be quadratic functions of (x, y),

$$u = b_1 + b_2x + b_3y + b_4x^2 + b_5xy + b_6y^2$$

$$v = b_7 + b_8x + b_9y + b_{10}x^2 + b_{11}xy + b_{12}y^2$$

where b_i ($i = 1, 2, \dots, 12$) are constants.

The strains are found to be,

$$\epsilon_x = b_2 + 2b_4x + b_5y$$

$$\epsilon_y = b_9 + b_{11}x + 2b_{12}y$$

$$\gamma_{xy} = (b_3 + b_8) + (b_5 + 2b_{10})x + (2b_6 + b_{11})y$$

which are linear functions. Thus, we have the “linear strain triangle” (LST), which provides better results than the CST.

In the natural coordinate system we defined earlier, the six shape functions for the LST element are,

$$N_1 = \xi(2\xi - 1)$$

$$N_2 = \eta(2\eta - 1)$$

$$N_3 = \zeta(2\zeta - 1)$$

$$N_4 = 4\xi\eta$$

$$N_5 = 4\eta\zeta$$

$$N_6 = 4\zeta\xi$$

in which $\zeta = 1 - \xi - \eta$

Each of these six shape functions represents a quadratic form on the element as shown in the following figure.

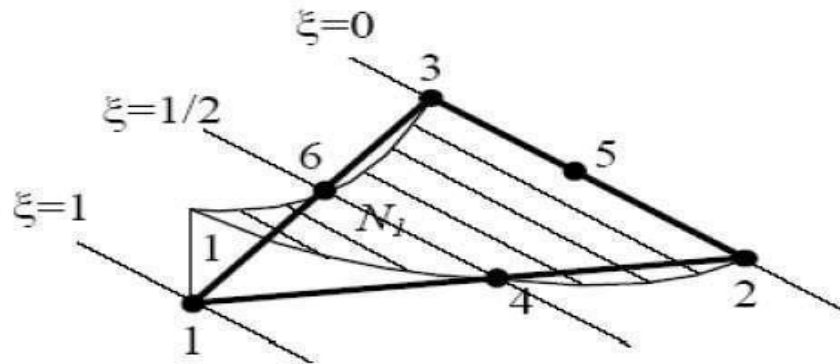

Displacements can be written as,

$$u = \sum_{i=1}^6 N_i u_i, \quad v = \sum_{i=1}^6 N_i v_i$$

Linear Quadrilateral Element (Q4)

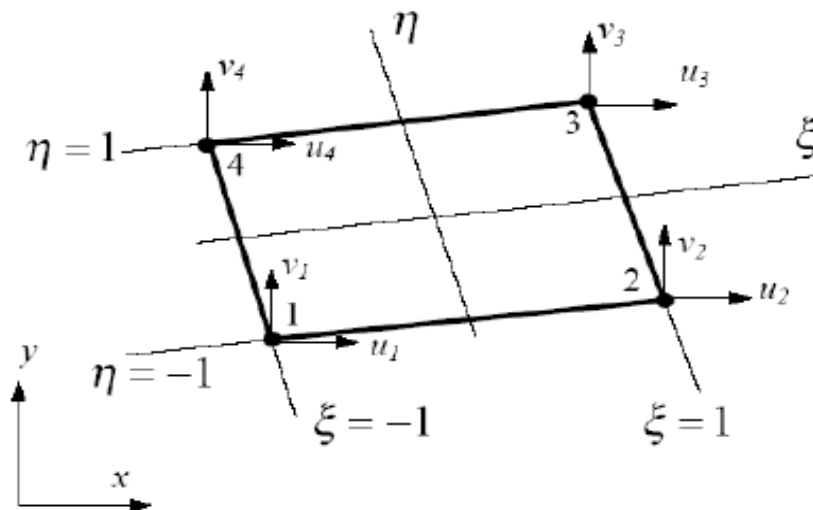

There are four nodes at the corners of the quadrilateral shape. In the natural coordinate system (ξ, η) , the four shape functions are,

$$N_1 = \frac{1}{4}(1-\xi)(1-\eta), \quad N_2 = \frac{1}{4}(1+\xi)(1-\eta)$$

$$N_3 = \frac{1}{4}(1+\xi)(1+\eta), \quad N_4 = \frac{1}{4}(1-\xi)(1+\eta)$$

$$\sum_{i=1}^4 N_i = 1 \quad \text{at any point inside the element.}$$

The displacement field is given by

$$u = \sum_{i=1}^4 N_i u_i, \quad v = \sum_{i=1}^4 N_i v_i$$

which are bilinear functions over the element.

Quadratic Quadrilateral Element (Q8)

This is the most widely used element for 2-D problems due to its high accuracy in analysis and flexibility in modeling.

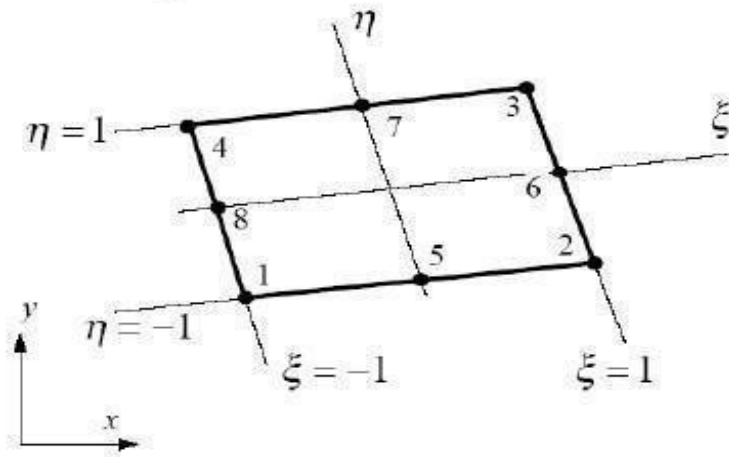

There are eight nodes for this element, four corners nodes and four mid-side nodes.

In the natural coordinate system (ξ, η) the eight shape functions are,

$$\begin{aligned} N_1 &= \frac{1}{4}(1-\xi)(\eta-1)(\xi+\eta+1) & N_5 &= \frac{1}{2}(1-\eta)(1-\xi^2) \\ N_2 &= \frac{1}{4}(1+\xi)(\eta-1)(\eta-\xi+1) & N_6 &= \frac{1}{2}(1+\xi)(1-\eta^2) \\ N_3 &= \frac{1}{4}(1+\xi)(1+\eta)(\xi+\eta-1) & N_7 &= \frac{1}{2}(1+\eta)(1-\xi^2) \\ N_4 &= \frac{1}{4}(\xi-1)(\eta+1)(\xi-\eta+1) & N_8 &= \frac{1}{2}(1-\xi)(1-\eta^2) \end{aligned}$$

Again, we have $\sum_{i=1}^8 N_i = 1$ at any point inside the element.

The displacement field is given by

$$u = \sum_{i=1}^8 N_i u_i, \quad v = \sum_{i=1}^8 N_i v_i$$

which are quadratic functions over the element. Strains and stresses over a quadratic quadrilateral element are quadratic functions, which are better representations.

Stress Calculation

The stress in an element is determined by the following relation,

$$\begin{Bmatrix} \sigma_x \\ \sigma_y \\ \tau_{xy} \end{Bmatrix} = \mathbf{E} \begin{Bmatrix} \varepsilon_x \\ \varepsilon_y \\ \gamma_{xy} \end{Bmatrix} = \mathbf{EBd}$$

where \mathbf{B} is the strain-nodal displacement matrix and \mathbf{d} is the nodal displacement vector which is known for each element once the global FE equation has been solved.

Stresses can be evaluated at any point inside the element (such as the center) or at the nodes. Contour plots are usually used in FEA software packages (during post-process) for users to visually inspect the stress results.

The von Mises Stress:

The von Mises stress is the *effective or equivalent stress* for 2-D and 3-D stress analysis.

$$\sigma_e = \frac{1}{\sqrt{2}} \sqrt{(\sigma_1 - \sigma_2)^2 + (\sigma_2 - \sigma_3)^2 + (\sigma_3 - \sigma_1)^2}$$

in which σ_1, σ_2 and σ_3 and are the three principle stresses at the considered point in a structure.

For 2-D problems, the two principle stresses in the plane are determined by

$$\sigma_1^p = \frac{\sigma_x + \sigma_y}{2} + \sqrt{\left(\frac{\sigma_x - \sigma_y}{2}\right)^2 + \tau_{xy}^2}$$
$$\sigma_2^p = \frac{\sigma_x + \sigma_y}{2} - \sqrt{\left(\frac{\sigma_x - \sigma_y}{2}\right)^2 + \tau_{xy}^2}$$

Thus, we can also express the von Mises stress in terms of the stress components in the *xy coordinate system*.

For plane stress conditions, we have,

$$\sigma_e = \sqrt{(\sigma_x + \sigma_y)^2 - 3(\sigma_x \sigma_y - \tau_{xy}^2)}$$

UNIT III

Elasticity Equations

Elasticity equations are used for solving structural mechanics problems. These equations must be satisfied if an exact solution to a structural mechanics problem is to be obtained. The types of elasticity equations are

1. Strain – Displacement relationship equations

$$e_x = \frac{\partial u}{\partial x}; e_y = \frac{\partial v}{\partial y}; \gamma_{xy} = \frac{\partial u}{\partial y} + \frac{\partial v}{\partial x}; \gamma_{xz} = \frac{\partial u}{\partial z} + \frac{\partial w}{\partial x};$$

$$\gamma_{yz} = \frac{\partial v}{\partial z} + \frac{\partial w}{\partial y}.$$

e_x – Strain in X direction, e_y – Strain in Y direction.

γ_{xy} - Shear Strain in XY plane, γ_{xz} - Shear Strain in XZ plane,

γ_{yz} - Shear Strain in YZ plane

2. Stress – Strain relationship equation

$$\begin{Bmatrix} \sigma_x \\ \sigma_y \\ \sigma_z \\ \tau_{xy} \\ \tau_{yz} \\ \tau_{zx} \end{Bmatrix} = \frac{E}{(1+\nu)(1-2\nu)} \begin{bmatrix} (1-\nu) & \nu & \nu & 0 & 0 & 0 \\ \nu & (1-\nu) & \nu & 0 & 0 & 0 \\ \nu & \nu & (1-\nu) & 0 & 0 & 0 \\ 0 & 0 & 0 & \frac{1-2\nu}{2} & 0 & 0 \\ 0 & 0 & 0 & 0 & \frac{1-2\nu}{2} & 0 \\ 0 & 0 & 0 & 0 & 0 & \frac{1-2\nu}{2} \end{bmatrix} \begin{Bmatrix} e_x \\ e_y \\ e_z \\ \gamma_{xy} \\ \gamma_{yz} \\ \gamma_{zx} \end{Bmatrix}$$

σ – Stress, τ – Shear Stress, E – Young’s Modulus, ν – Poisson’s Ratio, e – Strain, γ - Shear Strain.

3. Equilibrium equations

$$\frac{\partial \sigma_x}{\partial x} + \frac{\partial \tau_{xy}}{\partial y} + \frac{\partial \tau_{xz}}{\partial z} + B_x = 0; \quad \frac{\partial \sigma_y}{\partial y} + \frac{\partial \tau_{yz}}{\partial z} + \frac{\partial \tau_{xy}}{\partial x} + B_y = 0$$

$$\frac{\partial \sigma_z}{\partial z} + \frac{\partial \tau_{xz}}{\partial x} + \frac{\partial \tau_{yz}}{\partial y} + B_z = 0$$

σ – Stress, τ – Shear Stress, B_x - Body force at X direction,
 B_y - Body force at Y direction, B_z - Body force at Z direction.

4. Compatibility equations

There are six independent compatibility equations, one of which is

$$\frac{\partial^2 e_x}{\partial y^2} + \frac{\partial^2 e_y}{\partial x^2} = \frac{\partial^2 \gamma_{xy}}{\partial x \partial y}$$

The other five equations are similarly second order relations.

➤ Axisymmetric Elements

Most of the three dimensional problems are symmetry about an axis of rotation. Those types of problems are solved by a special two dimensional element called as axisymmetric element.

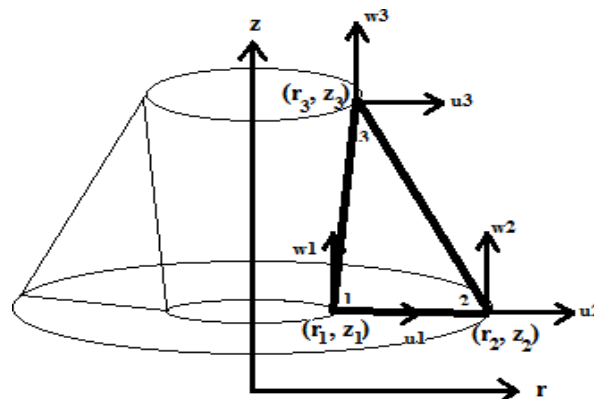

➤ Axisymmetric Formulation

The displacement vector u is given by

$$u(r, z) = \begin{Bmatrix} u \\ w \end{Bmatrix}$$

The stress σ is given by

$$\text{Stress, } \{\sigma\} = \begin{Bmatrix} \sigma_r \\ \sigma_\theta \\ \sigma_z \\ \tau_{rz} \end{Bmatrix}$$

The strain e is given by

$$\text{Strain, } \{e\} = \begin{Bmatrix} e_r \\ e_\theta \\ e_z \\ \gamma_{rz} \end{Bmatrix}$$

Equation of shape function for Axisymmetric element

Shape function,

$$N_1 = \frac{\alpha_1 + \beta_1 r + \gamma_1 z}{2A}; \quad N_2 = \frac{\alpha_2 + \beta_2 r + \gamma_2 z}{2A}; \quad N_3 = \frac{\alpha_3 + \beta_3 r + \gamma_3 z}{2A}$$

$$\alpha_1 = r_2 z_3 - r_3 z_2; \quad \alpha_2 = r_3 z_1 - r_1 z_3; \quad \alpha_3 = r_1 z_2 - r_2 z_1$$

$$\beta_1 = z_2 - z_3; \quad \beta_2 = z_3 - z_1; \quad \beta_3 = z_1 - z_2$$

$$\gamma_1 = r_3 - r_2; \quad \gamma_2 = r_1 - r_3; \quad \gamma_3 = r_2 - r_1$$

$$2A = (r_2 z_3 - r_3 z_2) - r_1 (r_3 z_1 - r_1 z_3) + z_1 (r_1 z_2 - r_2 z_1)$$

➤ Equation of Strain – Displacement Matrix [B] for Axisymmetric element

$$[B] = \frac{1}{2A} \begin{bmatrix} \beta_1 & r = \frac{r_1 + r_2 + r_3}{3} \beta_2 & 0 & \beta_3 & 0 \\ \frac{\alpha_1}{r} + \beta_1 + \frac{\gamma_1 z}{r} & 0 & \frac{\alpha_2}{r} + \beta_2 + \frac{\gamma_2 z}{r} & 0 & \frac{\alpha_3}{r} + \beta_3 + \frac{\gamma_3 z}{r} \\ 0 & \gamma_1 & 0 & \gamma_2 & 0 \\ \gamma_1 & \beta_1 & \gamma_2 & \beta_2 & \gamma_3 \end{bmatrix} \begin{Bmatrix} u_1 \\ w_1 \\ u_2 \\ w_2 \\ u_3 \\ w_3 \end{Bmatrix}$$

➤ Equation of Stress – Strain Matrix [D] for Axisymmetric element

$$[D] = \frac{E}{(1+\nu)(1-2\nu)} \begin{bmatrix} 1-\nu & \nu & \nu & 0 \\ \nu & 1-\nu & \nu & 0 \\ \nu & \nu & 1-\nu & 0 \\ 0 & 0 & 0 & \frac{1-2\nu}{2} \end{bmatrix}$$

➤ Equation of Stiffness Matrix [K] for Axisymmetric element

$$[K] = 2\pi r A [B]^T [D] [B]$$

$$r = \frac{r_1 + r_2 + r_3}{3}; A = (\frac{1}{2}) b x h$$

➤ Temperature Effects

The thermal force vector is given by $\{f\}_t = 2\pi r A [B] [D] \{e\}_t$

$$\{f\}_t = \begin{Bmatrix} F_1 u \\ F_1 w \\ F_2 u \\ F_2 w \\ F_3 u \\ F_3 w \end{Bmatrix}$$

➤ **Problem 1.** For the given element, determine the stiffness matrix. Take E=200GPa and ν= 0.25. 2.

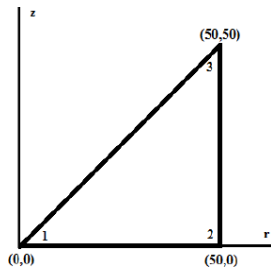

➤ 2. For the figure, determine the element stresses. Take E=2.1x10⁵N/mm² and ν= 0.25. The co-ordinates are in mm. The nodal displacements are u₁=0.05mm, w₁=0.03mm, u₂=0.02mm, w₂=0.02mm, u₃=0.0mm, w₃=0.0mm.

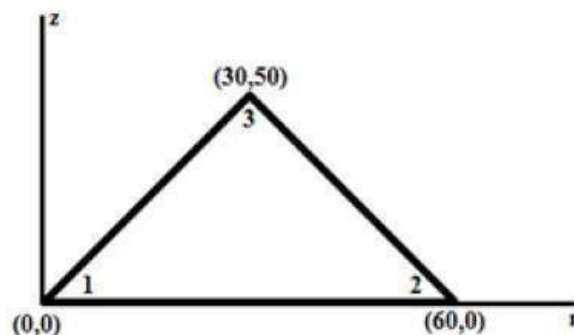

➤ 3. A long hollow cylinder of inside diameter 100mm and outside diameter 140mm is subjected to an internal pressure of 4N/mm^2 . By using two elements on the 15mm length, calculate the displacements at the inner radius.

➤ **Isoparametric element**

Generally it is very difficult to represent the curved boundaries by straight edge elements. A large number of elements may be used to obtain reasonable resemblance between original body and the assemblage. In order to overcome this drawback, isoparametric elements are used.

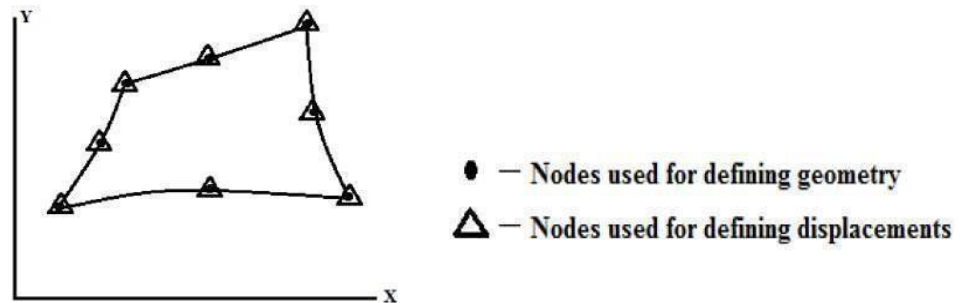

If the number of nodes used for defining the geometry is same as number of nodes used defining the displacements, then it is known as isoparametric element.

➤ **Superparametric element**

If the number of nodes used for defining the geometry is more than number of nodes used for defining the displacements, then it is known as super parametric element.

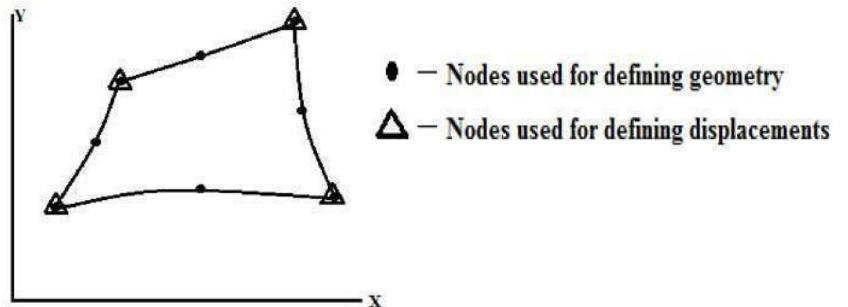

➤ **Subparametric element**

If the number of nodes used for defining the geometry is less than number of nodes used for defining the displacements, then it is known as subparametric element.

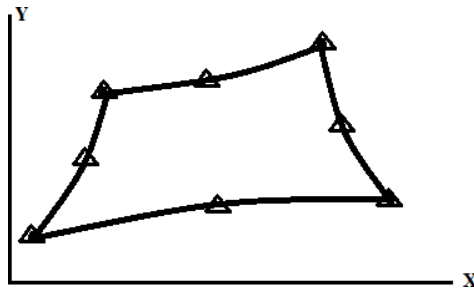

- – Nodes used for defining geometry
- △ – Nodes used for defining displacements

➤ Equation of Shape function for 4 noded rectangular parent element

$$u = \begin{Bmatrix} x \\ y \end{Bmatrix} = \begin{bmatrix} N_1 & 0 & N_2 & 0 & N_3 & 0 & N_4 & 0 \\ 0 & N_1 & 0 & N_2 & 0 & N_3 & 0 & N_4 \end{bmatrix} \begin{Bmatrix} x_1 \\ y_2 \\ x_1 \\ y_2 \\ x_3 \\ y_3 \\ x_4 \\ y_4 \end{Bmatrix}$$

$$N_1 = 1/4(1-\xi)(1-\eta); N_2 = 1/4(1+\xi)(1-\eta); N_3 = 1/4(1+\xi)(1+\eta); N_4 = 1/4(1-\xi)(1+\eta).$$

➤ Equation of Stiffness Matrix for 4 noded isoparametric quadrilateral element

$$[K] = t \int_{-1}^1 \int_{-1}^1 [B]^T [D][B] J d\xi d\eta$$

$$[J] = \begin{bmatrix} J_{11} & J_{12} \\ J_{21} & J_{22} \end{bmatrix};$$

$$J_{11} = \frac{1}{4} [-(1-\eta)x_1 + (1-\eta)x_2 + (1+\eta)x_3 - (1+\eta)x_4];$$

$$J_{12} = \frac{1}{4} [-(1-\eta)y_1 + (1-\eta)y_2 + (1+\eta)y_3 - (1+\eta)y_4];$$

$$J_{21} = \frac{1}{4} [-(1-\xi)x_1 - (1+\xi)x_2 + (1+\xi)x_3 + (1-\xi)x_4];$$

$$J_{22} = \frac{1}{4} [-(1-\xi)y_1 - (1+\xi)y_2 + (1+\xi)y_3 + (1-\xi)y_4];$$

$$[B] = \frac{1}{|J|} \begin{bmatrix} J_{22} & -J_{12} & 0 & 0 \\ 0 & 0 & -J_{21} & J_{11} \\ -J_{21} & J_{11} & J_{22} & -J_{12} \end{bmatrix} \begin{bmatrix} \frac{\partial N_1}{\partial x} & 0 & \frac{\partial N_2}{\partial x} & 0 & \frac{\partial N_3}{\partial x} & 0 & \frac{\partial N_4}{\partial x} & 0 \\ \frac{\partial N_1}{\partial y} & 0 & \frac{\partial N_2}{\partial y} & 0 & \frac{\partial N_3}{\partial y} & 0 & \frac{\partial N_4}{\partial y} & 0 \\ 0 & \frac{\partial N_1}{\partial x} & 0 & \frac{\partial N_2}{\partial x} & 0 & \frac{\partial N_3}{\partial x} & 0 & \frac{\partial N_4}{\partial x} \\ 0 & \frac{\partial N_1}{\partial y} & 0 & \frac{\partial N_2}{\partial y} & 0 & \frac{\partial N_3}{\partial y} & 0 & \frac{\partial N_4}{\partial y} \end{bmatrix}$$

$$[D] = \frac{E}{(1-\nu^2)} \begin{bmatrix} 1-\nu & \nu & 0 \\ \nu & 1 & 0 \\ 0 & 0 & \frac{1-\nu}{2} \end{bmatrix}, \text{ for plane stress conditions;}$$

$$[D] = \frac{E}{(1+\nu)(1-2\nu)} \begin{bmatrix} 1-\nu & \nu & 0 \\ \nu & 1-\nu & 0 \\ 0 & 0 & \frac{1-2\nu}{2} \end{bmatrix}, \text{ for plane strain conditions.}$$

➤ **Equation of element force vector**

$$\{F\}_e = [N]^T \begin{Bmatrix} F_x \\ F_y \end{Bmatrix};$$

N – Shape function, F_x – load or force along x direction, F_y – load or force along y direction.

➤ **Numerical Integration (Gaussian Quadrature)**

The Gauss quadrature is one of the numerical integration methods to calculate the definite integrals. In FEA, this Gauss quadrature method is mostly preferred. In this method the numerical integration is

$$\int_{-1}^1 f(x) dx = \sum_{i=1}^n w_i f(x_i)$$

achieved by the following expression,

Table gives gauss points for integration from -1 to 1.

Number of Points n	Location x_i	Corresponding Weights w_i
1	$x_1 = 0.000$	2.000
2	$x_1, x_2 = \pm \sqrt{\frac{1}{3}} = \pm 0.577350269189$	1.000
3	$x_1, x_3 = \pm \sqrt{\frac{3}{5}} = \pm 0.774596669241$ $x_2 = 0.000$	$\frac{5}{9} = 0.555555$ $\frac{8}{9} = 0.888888$
4	$x_1, x_4 = \pm 0.8611363116$ $x_2, x_3 = \pm 0.3399810436$	0.3478548451 0.6521451549

- **Problem** 1. Evaluate, $I = \int_{-1}^1 \cos \frac{\pi x}{2} dx$, by applying 3 point Gaussian quadrature and compare with exact solution.
2. Evaluate, $I = \int_{-1}^1 \left[3e^x + x^2 + \frac{1}{x+2} \right] dx$, using one point and two point Gaussian quadrature. Compare with exact solution.
3. For the isoparametric quadrilateral element shown in figure, determine the local co-ordinates of the point P which has Cartesian co-ordinates (7, 4).

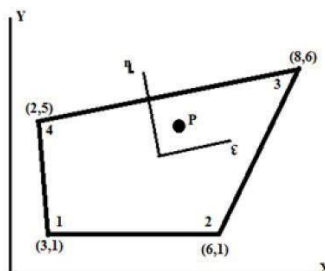

4. A four noded rectangular element is in figure. Determine (i) Jacobian matrix, (ii) Strain – Displacement matrix and (iii) Element

Stresses. Take $E=2 \times 10^5 \text{ N/mm}^2$, $\nu=0.25$, $u=[0,0,0.003,0.004,0.006,0.004,0,0]^T$, $\epsilon=0$, $\eta=0$. Assume plane stress condition.

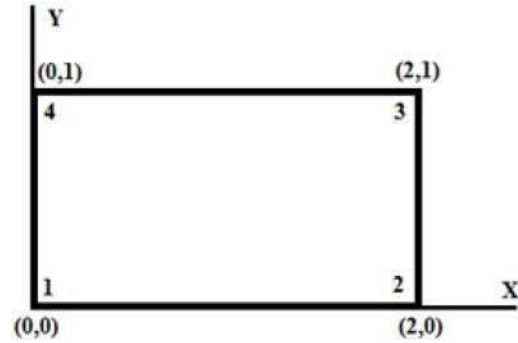

UNIT IV

One could obtain the global stiffness matrix of a continuous beam from assembling member stiffness matrix of individual beam elements. Towards this end, we break the given beam into a number of beam elements. The stiffness matrix of each individual beam element can be written very easily. For example, consider a continuous beam $ABCD$ as shown in Fig. 1a. The given continuous beam is divided into three beam elements as shown in Fig. 1b. It is noticed that, in this case, nodes are located at the supports. Thus each span is treated as an individual beam. However sometimes it is required to consider a node between support points. This is done whenever the cross sectional area changes suddenly or if it is required to calculate vertical or rotational displacements at an intermediate point. Such a division is shown in Fig. 1c. If the axial deformations are neglected then each node of the beam will have two degrees of freedom: a vertical displacement (corresponding to shear) and a rotation (corresponding to bending moment). In Fig. 1b, numbers enclosed in a circle represents beam numbers. The beam $ABCD$ is divided into three beam members. Hence, there are four nodes and eight degrees of freedom. The possible displacement degrees of freedom of the beam are also shown in the figure. Let us use lower numbers to denote unknown degrees of freedom (unconstrained degrees of freedom) and higher numbers to denote known (constrained) degrees of freedom. Such a method of identification is adopted in this course for the ease of imposing boundary conditions directly on the structure stiffness matrix. However, one could number sequentially as shown in Fig. 1d. This is preferred while solving the problem on a computer.

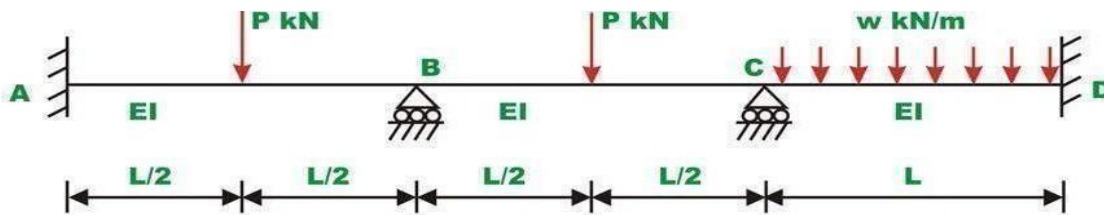

Fig 27.1a Continuous beam

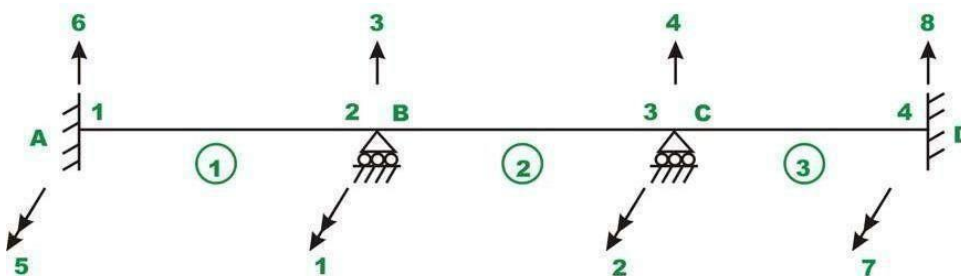

Fig. 27.1b Member and node numbering

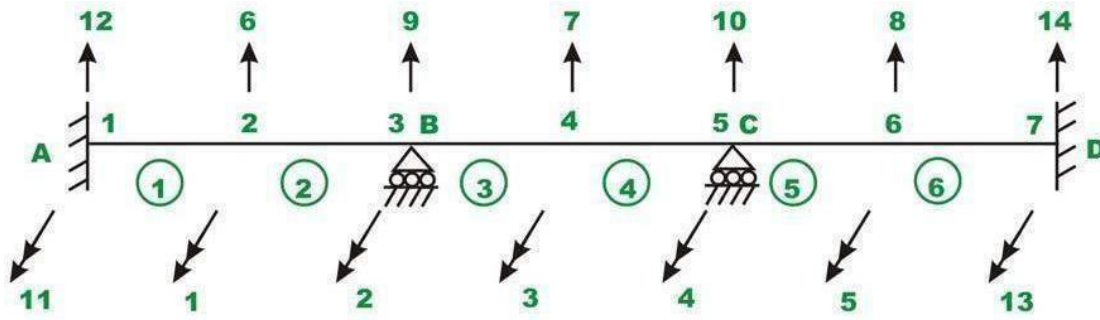

Fig. 27.1c Member and node numbering

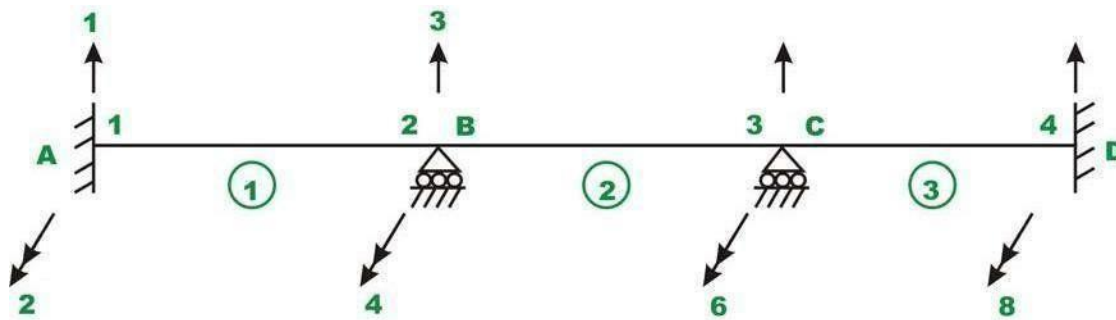
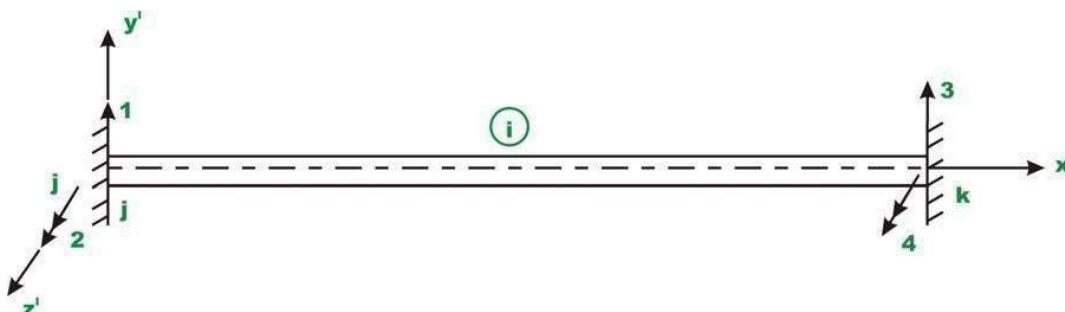

Fig 27.1d Member and node numbering

In the above figures, single headed arrows are used to indicate translational and double headed arrows are used to indicate rotational degrees of freedom.

Beam Stiffness Matrix:

Fig. 2 shows a prismatic beam of a constant cross section that is fully restrained at ends in local orthogonal coordinate system $x' y' z'$. The beam ends are denoted by nodes j and k . The x' axis coincides with the centroidal axis of the member with the positive sense being defined from j to k . Let L be the length of the member, A area of cross section of the member and I_{zz} is the moment of inertia about z' axis.



Two degrees of freedom (one translation and one rotation) are considered at each end of the member. Hence, there are four possible degrees of freedom for this member and hence the resulting stiffness matrix is of the order 4×4 . In this method counterclockwise moments and counterclockwise rotations are taken as positive. The positive sense of the translation and rotation are also shown in the figure. Displacements are considered as positive in the direction of the co-ordinate axis. The elements of the stiffness matrix indicate the forces exerted on the the member by the restraints at the ends of the member when unit displacements are imposed at each end of the member. Let us calculate the forces developed in the above beam member when unit displacement is imposed along each degree of freedom holding all other displacements to zero. Now impose a unit displacement along y' axis at j end of the member while holding all other displacements to zero as shown in Fig.a. This displacement causes both shear and moment in the beam. The restraint actions are also shown in the figure. By definition they are elements of the member stiffness matrix. In particular they form the first column of element stiffness matrix.

In Fig.b, the unit rotation in the positive sense is imposed at j end of the beam while holding all other displacements to zero. The restraint actions are shown in the figure. The restraint actions at ends are calculated referring to tables given in lesson...

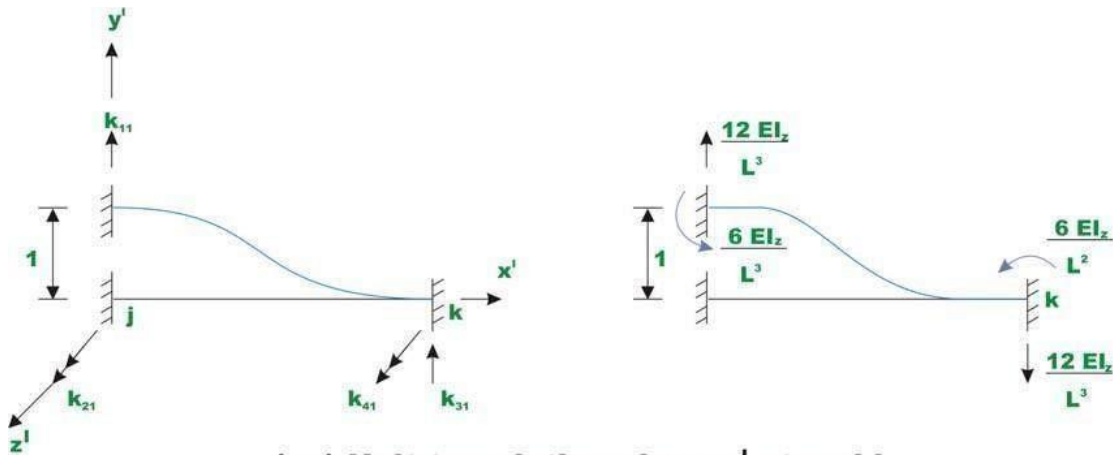

(a) Unit translation along y' at end j

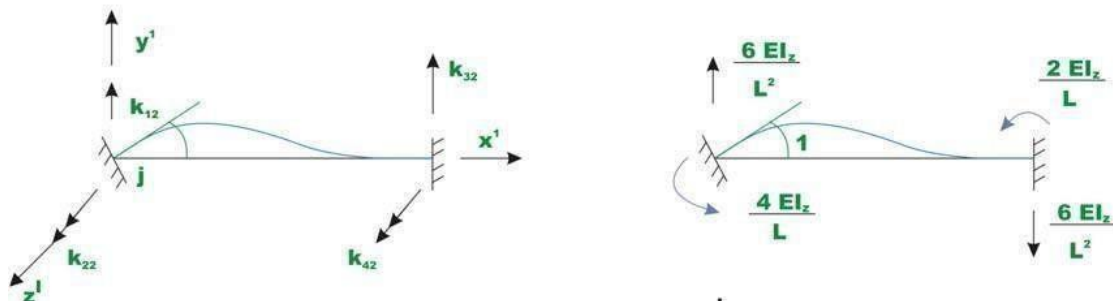

(b) Unit rotation about z' at end j

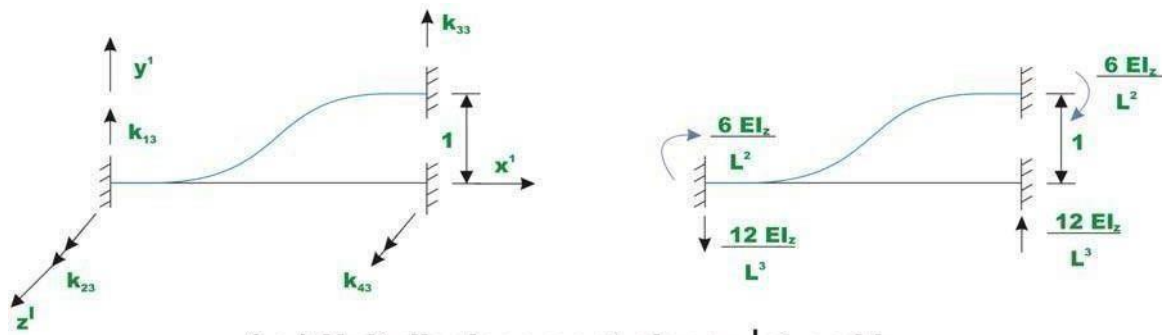

(c) Unit displacement along y' at end k

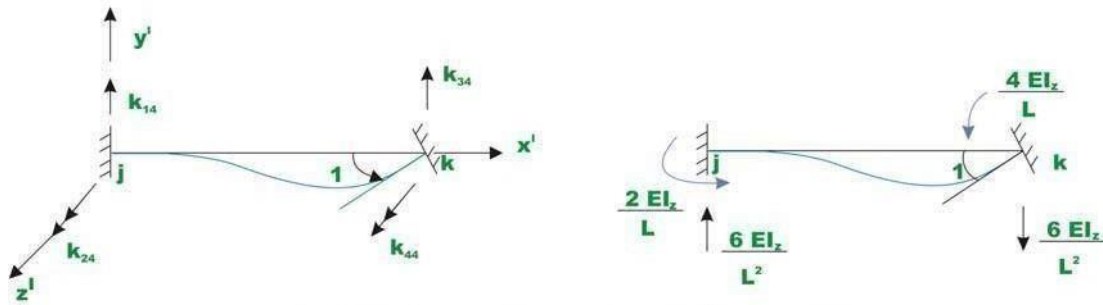

(d) Unit rotation about z' at end k

In Fig. 3c, unit displacement along y' axis at end k is imposed and corresponding restraint actions are calculated. Similarly in Fig.d, unit rotation about z' axis at end k is imposed and corresponding stiffness coefficients are calculated. Hence the member stiffness matrix for the beam member is

$$[k] = \begin{bmatrix} 1 & 2 & 3 & 4 \\ \frac{12EI_z}{L^3} & \frac{6EI_z}{L^2} & -\frac{12EI_z}{L^3} & \frac{6EI_z}{L^2} \\ \frac{6EI_z}{L^2} & \frac{4EI_z}{L} & -\frac{6EI_z}{L^2} & \frac{2EI_z}{L} \\ \frac{L^2}{12EI_z} & -\frac{L}{6EI_z} & \frac{L^2}{12EI_z} & -\frac{L}{6EI_z} \\ -\frac{L^3}{6EI_z} & \frac{L^2}{2EI_z} & -\frac{L^3}{6EI_z} & \frac{L^2}{4EI_z} \\ \frac{L^2}{L^2} & \frac{L}{L} & -\frac{L^2}{L^2} & \frac{L}{L} \end{bmatrix}$$

The stiffness matrix is symmetrical. The stiffness matrix is partitioned to separate the actions associated with two ends of the member. For continuous beam problem, if the supports are unyielding, then only rotational degree of freedom shown in Fig. is possible. In such a case the first and the third rows and columns will be deleted. The reduced stiffness matrix will be,

$$[k] = \begin{bmatrix} \frac{4EI_z}{L} & \frac{2EI_z}{L} \\ \frac{2EI_z}{L} & \frac{4EI_z}{L} \end{bmatrix}$$

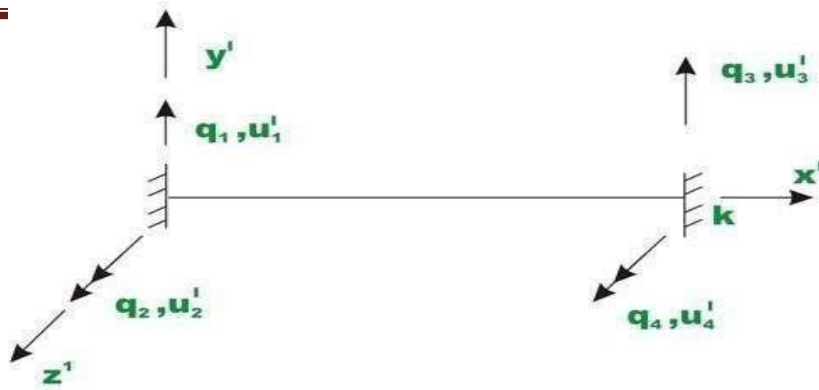

Instead of imposing unit displacement along y' at j end of the member in Fig.a, apply a displacement u'_1 along y' at j end of the member as shown in Fig. a, holding all other displacements to zero. Let the restraining forces developed be denoted by q_{11} , q_{21} , q_{31} and q_{41} .

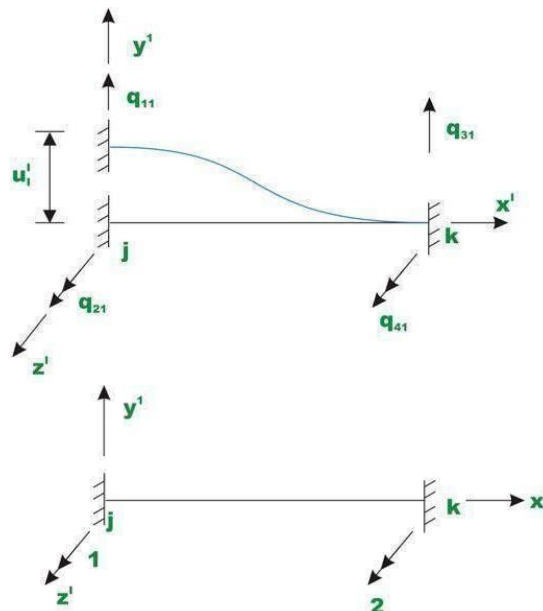

The forces are equal to,

$$q_{11} = k_{11}u'_1; \quad q_{21} = k_{21}u'_1; \quad q_{31} = k_{31}u'_1; \quad q_{41} = k_{41}u'_1$$

Now, give displacements u'_1 , u'_2 , u'_3 and u'_4 simultaneously along displacement degrees of freedom 1, 2, 3 and 4 respectively. Let the restraining forces developed at member ends be q_1 , q_2 , q_3 and q_4 respectively as shown in Fig. b along respective degrees of freedom. Then by the principle of superposition, the force displacement relationship can be written as,

$$\begin{bmatrix} q_1 \\ q_2 \\ q_3 \\ q_4 \end{bmatrix} = \begin{bmatrix} \frac{12EI_z}{L^3} & \frac{6EI_z}{L^2} & -\frac{12EI_z}{L^3} & \frac{6EI_z}{L^2} \\ \frac{6EI_z}{L^2} & \frac{4EI_z}{L} & -\frac{6EI_z}{L^2} & \frac{2EI_z}{L} \\ -\frac{12EI_z}{L^3} & -\frac{6EI_z}{L^2} & \frac{12EI_z}{L^3} & -\frac{6EI_z}{L^2} \\ \frac{6EI_z}{L^2} & \frac{2EI_z}{L} & -\frac{6EI_z}{L^2} & \frac{4EI_z}{L} \end{bmatrix} \begin{bmatrix} u'_1 \\ u'_2 \\ u'_3 \\ u'_4 \end{bmatrix}$$

This may also be written in compact form as,

$$\{q\} = [k] \{u'\}$$

Beam (global) Stiffness Matrix:

The formation of structure (beam) stiffness matrix from its member stiffness matrices is explained with help of two span continuous beams shown in Fig. a. Note that no loading is shown on the beam. The orthogonal co-

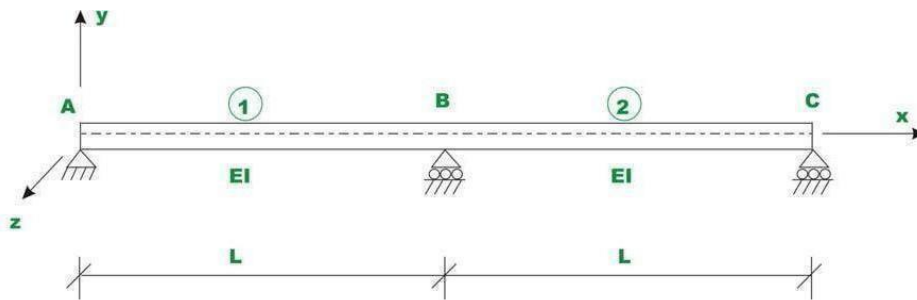

ordinate system xyz denotes the global co-ordinate system.

For the case of continuous beam, the x - and x' - axes are collinear and other axes (y and y' , z and z') are parallel to each other. Hence it is not required to transform member stiffness matrix from local co-ordinate system to global coordinate system as done in the case of trusses. For obtaining the global stiffness matrix, first assume that all joints are restrained. The node and member numbering for the possible degrees of freedom are

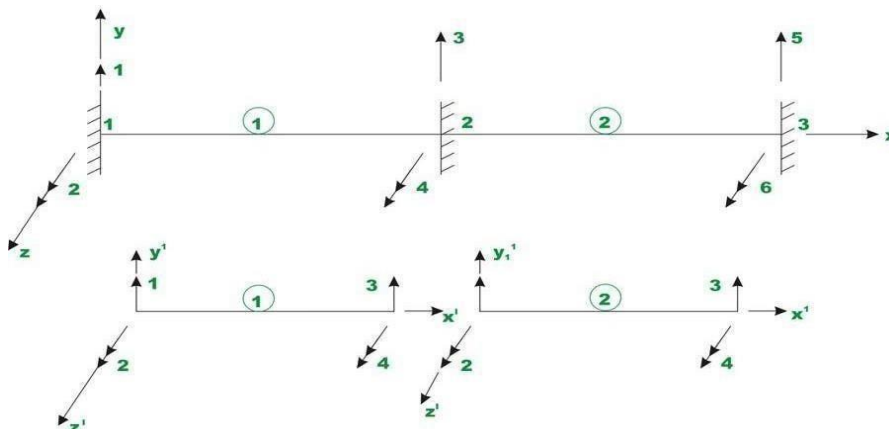

shown in Fig b. The continuous beam is divided into two beam members. For this member there are six possible degrees of freedom. Also in the figure, each beam member with its displacement degrees of freedom (in local co ordinate system) is also shown. Since the continuous beam has the same moment of inertia and span, the member stiffness matrix of element 1 and 2 are the same. They are,

$$\begin{array}{l}
 \text{Global d.o.f} \quad 1 \quad 2 \quad 3 \quad 4 \\
 \text{Local d.o.f} \quad 1 \quad 2 \quad 3 \quad 4
 \end{array}$$

$$[k'] = \begin{bmatrix} k'_{11} & k'_{12} & k'_{13} & k'_{14} \\ k'_{21} & k'_{22} & k'_{23} & k'_{24} \\ k'_{31} & k'_{32} & k'_{33} & k'_{34} \\ k'_{41} & k'_{42} & k'_{43} & k'_{44} \end{bmatrix} \begin{array}{l} 1 \\ 2 \\ 3 \\ 4 \end{array}$$

$$\begin{array}{l}
 \text{Global d.o.f} \quad 3 \quad 4 \quad 5 \quad 6 \\
 \text{Local d.o.f} \quad 1 \quad 2 \quad 3 \quad 4
 \end{array}$$

$$[k^2] = \begin{bmatrix} k^2_{11} & k^2_{12} & k^2_{13} & k^2_{14} \\ k^2_{21} & k^2_{22} & k^2_{23} & k^2_{24} \\ k^2_{31} & k^2_{32} & k^2_{33} & k^2_{34} \\ k^2_{41} & k^2_{42} & k^2_{43} & k^2_{44} \end{bmatrix} \begin{array}{l} 1 \\ 2 \\ 3 \\ 4 \end{array}$$

The local and the global degrees of freedom are also indicated on the top and side of the element stiffness matrix. This will help us to place the elements of the element stiffness matrix at the appropriate locations of the global stiffness matrix. The continuous beam has six degrees of freedom and hence the stiffness matrix is of the order 6. Let [K] denotes the continuous beam stiffness matrix of order 6X6. From Fig., [K] may be written as,

$$\begin{array}{c}
 \text{Member } AB \text{ (1)} \\
 [K] = \left[\begin{array}{cc|cc|cc}
 k_{11}^1 & k_{12}^1 & k_{13}^1 & k_{14}^1 & 0 & 0 \\
 k_{21}^1 & k_{22}^1 & k_{23}^1 & k_{24}^1 & 0 & 0 \\
 \hline
 k_{31}^1 & k_{32}^1 & k_{33}^1 + k_{11}^2 & k_{34}^1 + k_{12}^2 & k_{13}^2 & k_{14}^2 \\
 k_{41}^1 & k_{42}^1 & k_{43}^1 + k_{21}^2 & k_{44}^1 + k_{22}^2 & k_{23}^2 & k_{24}^2 \\
 \hline
 0 & 0 & k_{31}^2 & k_{32}^2 & k_{33}^2 & k_{34}^2 \\
 0 & 0 & k_{41}^2 & k_{42}^2 & k_{43}^2 & k_{44}^2
 \end{array} \right] \\
 \text{Member } BC \text{ (2)}
 \end{array}$$

The 4X4 upper left hand section receives contribution from member 1 (AB) and 4X4 lower right hand section of global stiffness matrix receives contribution from member 2. The element of the global stiffness matrix corresponding to global degrees of freedom 3 and 4 receives element from both members 1 and 2.

FORMATION OF LOAD VECTOR:

Consider a continuous beam ABC as shown in Fig.

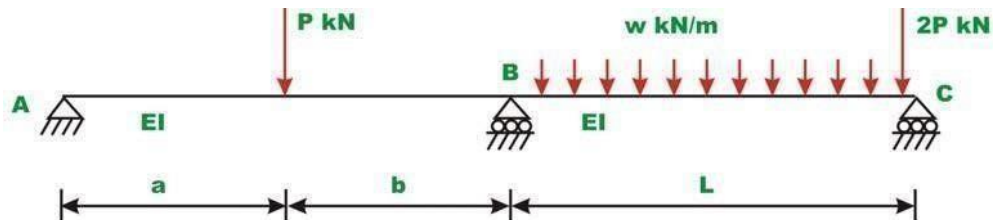

We have two types of load: member loads and joint loads. Joint loads could be handled very easily as done in case of trusses. Note that stiffness matrix of each member was developed for end loading only. Thus it is required to replace the member loads by equivalent joint loads. The equivalent joint loads must be evaluated such that the displacements produced by them in the beam should be the same as the displacements produced by the actual loading on the beam. This is evaluated by invoking the method of superposition.

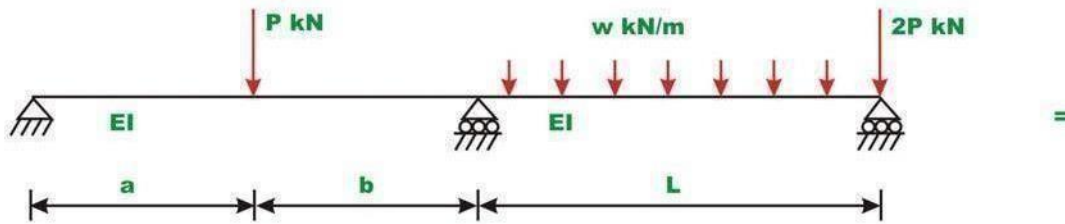

(a) Actual beam with loading

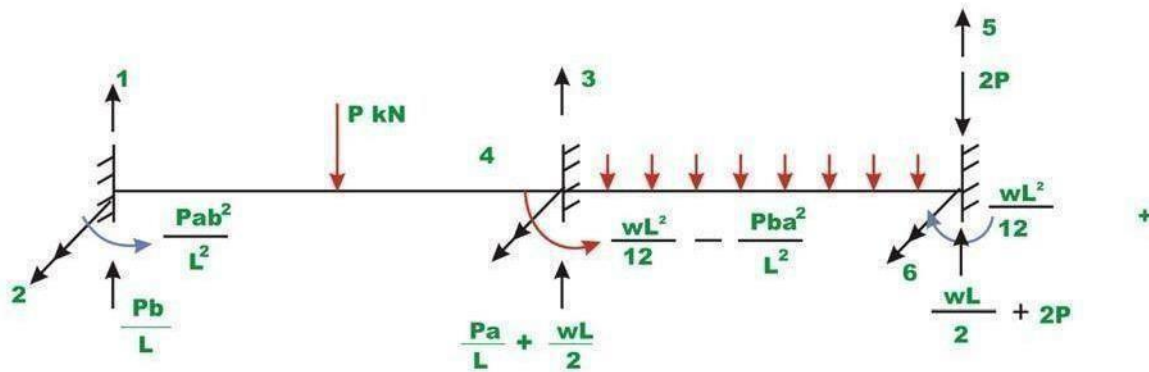

(b) Reaction in the restrained beam

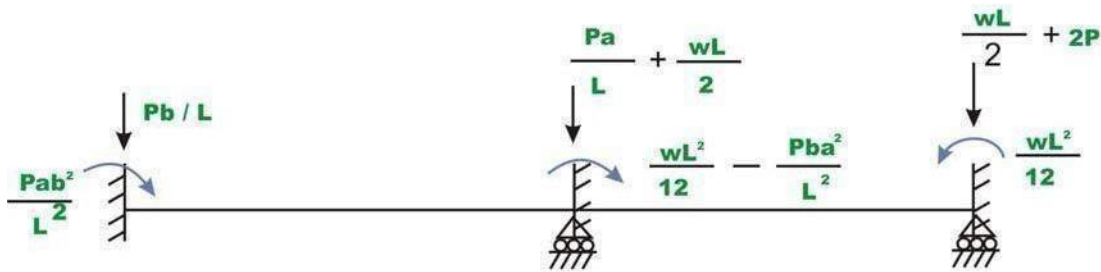

(c) Equivalent joint loads

The loading on the beam shown in Fig. (a), is equal to the sum of Fig. (b) and Fig. (c). In Fig. (c), the joints are restrained against displacements and fixed end forces are calculated. In Fig. (c) these fixed end actions are shown in reverse direction on the actual beam without any load. Since the beam in Fig. (b) is restrained (fixed) against any displacement, the displacements produced by the joint loads in Fig. (c) must be equal to the displacement produced by the actual beam in Fig. (a). Thus the loads shown in Fig. (c) are the equivalent joint loads. Let, p_1, p_2, p_3, p_4, p_5 and p_6 be the equivalent joint loads acting on the continuous beam along displacement degrees of freedom 1,2,3,4,5 and 6 respectively as shown in Fig. (b). Thus the global load vector is,

$$\begin{Bmatrix} p_1 \\ p_2 \\ p_3 \\ p_4 \\ p_5 \\ p_6 \end{Bmatrix} = \begin{Bmatrix} -\frac{Pb}{L} \\ -\frac{Pab^2}{L^2} \\ -\left(\frac{Pa}{L} + \frac{wL}{2}\right) \\ -\left(\frac{wL^2}{12} - \frac{Pba^2}{L^2}\right) \\ -\left(\frac{wL}{2} + 2P\right) \\ \frac{wL^2}{12} \end{Bmatrix}$$

SOLUTION OF EQUILIBRIUM EQUATIONS:

After establishing the global stiffness matrix and load vector of the beam, the load displacement relationship for the beam can be written as

$$\{P\} = [K]\{u\}$$

Where $\{P\}$ is the global load vector, $\{u\}$ is displacement vector and $[K]$ is the global stiffness matrix. In the above equation some joint displacements are known from support conditions. The above equation may be written as

$$\begin{Bmatrix} \{p_k\} \\ \{p_u\} \end{Bmatrix} = \begin{bmatrix} [k_{11}] & [k_{12}] \\ [k_{21}] & [k_{22}] \end{bmatrix} \begin{Bmatrix} \{u_u\} \\ \{u_k\} \end{Bmatrix}$$

Where $\{p_k\}$ and $\{u_k\}$ denote respectively vector of known forces and known displacements. And $\{p_u\}$ and $\{u_u\}$ denote respectively vector of unknown forces and unknown displacements respectively. Now expanding equation

$$\{p_k\} = [k_{11}]\{u_u\} + [k_{12}]\{u_k\}$$

$$\{p_u\} = [k_{21}]\{u_u\} + [k_{22}]\{u_k\}$$

Since $\{u_k\}$ is known, the unknown joint displacements can be evaluated. And support reactions are evaluated from equation, after evaluating unknown displacement vector.

Let R_1, R_3 and R_5 be the reactions along the constrained degrees of freedom. Since equivalent joint loads are directly applied at the supports, they also need to be considered while calculating the actual reactions. Thus,

$$\begin{Bmatrix} R_1 \\ R_3 \\ R_5 \end{Bmatrix} = - \begin{Bmatrix} P_1 \\ P_3 \\ P_5 \end{Bmatrix} + [K_{21}]\{u_u\}$$

The reactions may be calculated as follows. The reactions of the beam shown in Fig. a are equal to the sum of reactions shown in Fig. b, Fig. c and Fig. d.

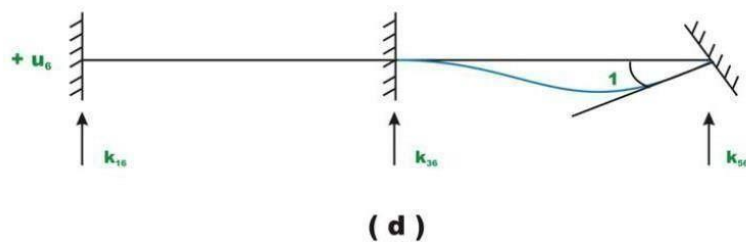
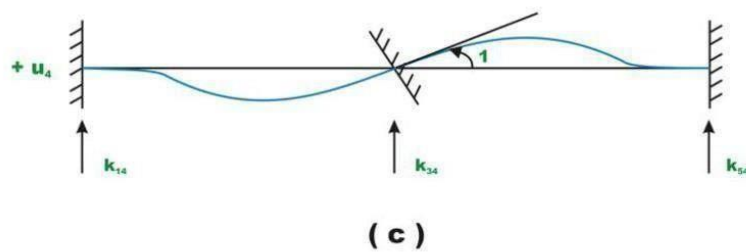
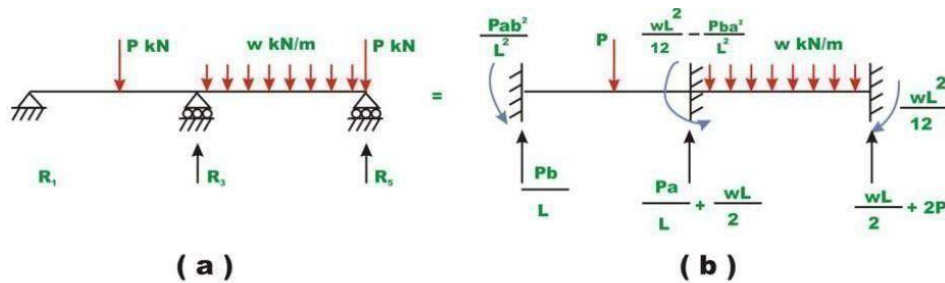

From the method of superposition,

$$R_1 = \frac{Pb}{L} + K_{14}u_4 + K_{16}u_6$$

$$R_3 = \frac{Pa}{L} + K_{34}u_4 + K_{36}u_6$$

$$R_5 = \frac{wL}{2} + 2P + K_{54}u_4 + K_{56}u_6$$

or

$$\begin{Bmatrix} R_1 \\ R_3 \\ R_5 \end{Bmatrix} = \begin{Bmatrix} Pb/L \\ Pa/L \\ \frac{wl}{2} + 2P \end{Bmatrix} + \begin{bmatrix} K_{14} & K_{16} \\ K_{34} & K_{36} \\ K_{54} & K_{56} \end{bmatrix} \begin{Bmatrix} u_4 \\ u_6 \end{Bmatrix}$$

$$\begin{Bmatrix} R_1 \\ R_3 \\ R_5 \end{Bmatrix} = - \begin{Bmatrix} Pb/L \\ Pa/L \\ \frac{wl}{2} + 2P \end{Bmatrix} + \begin{bmatrix} K_{14} & K_{16} \\ K_{34} & K_{36} \\ K_{54} & K_{56} \end{bmatrix} \begin{Bmatrix} u_4 \\ u_6 \end{Bmatrix}$$

Member end actions q_1 , q_2 , q_3 and q_4 are calculated as follows. For example consider the first element 1

$$\begin{Bmatrix} q_1 \\ q_2 \\ q_3 \\ q_4 \end{Bmatrix} = \begin{Bmatrix} \frac{Pb}{L} \\ \frac{Pab^2}{L^2} \\ \frac{Pa}{L} \\ \frac{L}{Pa^2b} \\ -\frac{L^2}{L^2} \end{Bmatrix} + [K]_{\text{element1}} \begin{Bmatrix} 0 \\ u_2 \\ 0 \\ u_4 \end{Bmatrix}$$

UNIT V

Dynamic analysis

- **Modal analysis** - Natural frequency and mode shapes
- **Harmonic analysis** - Forced response of system to a sinusoidal forcing
- **Transient analysis** - Forced response for non-harmonic loads (impact, step or ramp forcing etc.)

DYNAMIC CONSIDERATIONS

Static analysis holds when the loads are slowly applied. When the loads are suddenly applied, or when the loads are of a variable nature, the mass and acceleration effects come into the picture. If a solid body, such as an engineering structure, is deformed elastically and suddenly released, it tends to vibrate about its equilibrium position. This periodic motion due to the restoring strain energy is called **free vibration**.

The number of cycles per unit time is called **frequency**.

The maximum displacement from the equilibrium position is the **amplitude**.

FORMULATION

We define the Lagrangean by

$$L = T - \Pi$$

where T is the kinetic energy and Π is the potential energy.

Hamilton's principle For an arbitrary time interval from t_1 to t_2 , the state of motion of a body extremizes the functional

$$I = \int_{t_1}^{t_2} L dt$$

If L can be expressed in terms of the generalized variables $(q_1, q_2, \dots, q_n, \dot{q}_1, \dot{q}_2, \dots, \dot{q}_n)$ where $\dot{q}_i = dq_i/dt$, then the equations of motion are given by

$$\frac{d}{dt} \left(\frac{\partial L}{\partial \dot{q}_i} \right) - \frac{\partial L}{\partial q_i} = 0 \quad i=1 \text{ to } n$$

Example

Consider the spring-mass system in Fig.. The kinetic and potential energies are given by

$$T = \frac{1}{2} m_1 \dot{x}_1^2 + \frac{1}{2} m_2 \dot{x}_2^2$$

$$\Pi = \frac{1}{2} k_1 x_1^2 + \frac{1}{2} k_2 (x_2 - x_1)^2$$

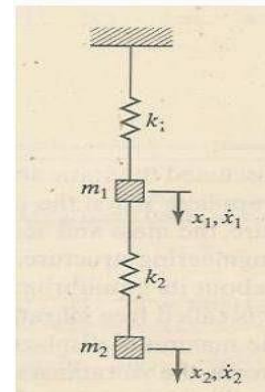

Using $L = T - \Pi$, we obtain the equations of motion

$$\frac{d}{dt} \left(\frac{\partial L}{\partial \dot{x}_1} \right) - \frac{\partial L}{\partial x_1} = m_1 \ddot{x}_1 + k_1 x_1 - k_2 (x_2 - x_1) = 0$$

$$\frac{d}{dt} \left(\frac{\partial L}{\partial \dot{x}_2} \right) - \frac{\partial L}{\partial x_2} = m_2 \ddot{x}_2 + k_2 (x_2 - x_1) = 0$$

Which can be written in the form

$$\begin{bmatrix} m_1 & 0 \\ 0 & m_2 \end{bmatrix} \begin{Bmatrix} \ddot{x}_1 \\ \ddot{x}_2 \end{Bmatrix} + \begin{bmatrix} (k_1+k_2) & -k_2 \\ -k_2 & k_2 \end{bmatrix} \begin{Bmatrix} x_1 \\ x_2 \end{Bmatrix} = 0$$

which is of the form

$$M\ddot{x} + Kx = 0$$

where M is the mass matrix, K is the stiffness matrix, and representing accelerations and displacements.

\ddot{x} and x are vectors

Solid Body with Distributed Mass

Consider a solid body with distributed mass. The kinetic energy is given by

$$T = \frac{1}{2} \int_V \dot{u}^T \dot{u} \rho dV$$

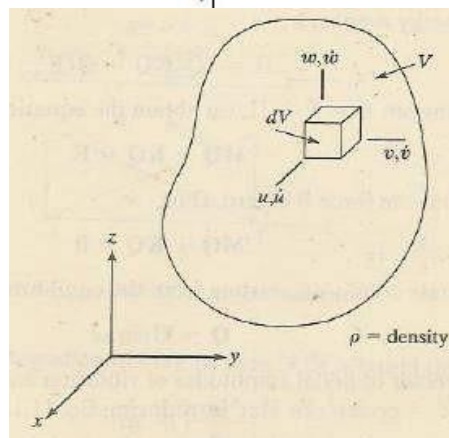

where ρ is the density (mass per unit volume) of the material and

$$\dot{u} = [\dot{u}, \dot{v}, \dot{w}]^T$$

is the velocity vector of the point at \mathbf{x} , with components In the finite element method, we divide the body into elements, and in each element,

we express u in terms of the nodal displacements \mathbf{q} , using shape functions N .

$$\mathbf{u} = N\mathbf{q}$$

In dynamic analysis, the elements of \mathbf{q} are dependent on time, while N represents (spatial) shape functions defined on a master element. The velocity vector is then given by

$$\dot{u} = N\dot{q}$$

the kinetic energy T_e in element e is

$$T = \frac{1}{2} \dot{q}^T \left[\int_e \rho N^T N dV \right] \dot{q}$$

where the bracketed expression is the element mass matrix

$$m^e = \int_e \rho N^T N dV$$

This mass matrix is consistent with the shape functions chosen and is called the consistent mass matrix. On summing over all the elements, we get

$$T = \sum_e T_e = \sum_e \frac{1}{2} \dot{q}^T m^e \dot{q} = \frac{1}{2} \dot{Q}^T M \dot{Q}$$

$$\Pi = \frac{1}{2} Q^T K Q - Q^T F$$

Using the Lagrangean $L = T - \Pi$, we obtain the equation of motion:

$$M \ddot{Q} + K Q = F$$

For free vibrations the force F is zero. Thus,

$$M \ddot{Q} + K Q = 0$$

For the steady-state conditions, starting from the equilibrium state, we get

$$Q = U \sin \omega t$$

where U is the vector of modal amplitudes of vibration and ω (*rad/s*) is the circular frequency ($2\pi f$, $f = \text{cycles/s or Hz}$).

$$K U = \omega^2 M U$$

This is the generalized eigen value problem

$$K U = \lambda M U$$

ELEMENT MASS MATRICES

Treating the material density ρ to be constant over the element, we have,

$$m^e = \rho \int_e N^T N dV$$

One-dimensional bar element For the bar element

$$N_1 = \frac{1-\xi}{2} \quad N_2 = \frac{1+\xi}{2}$$

$$q^T = [q_1 \quad q_2]$$

$$N = [N_1 \quad N_2]$$

$$m^e = \rho \int_e N^T N A dx = \frac{\rho A_e \ell_e}{2} \int_{-1}^{+1} N^T N d\xi$$

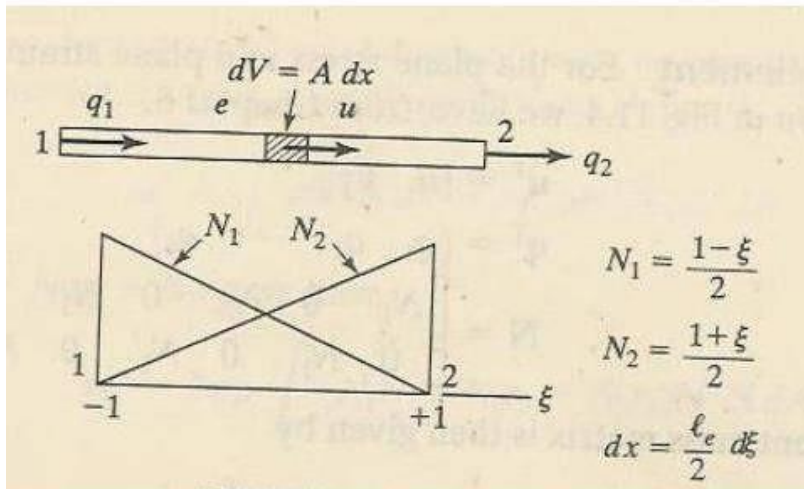

On carrying out the integration of each term in $N^T N$, we find that

$$m^e = \frac{\rho A_e \ell_e}{6} \begin{bmatrix} 2 & 1 \\ 1 & 2 \end{bmatrix}$$

Truss element For the truss element

$$u^T = [u, \quad v]$$

$$q^T = [q_1 \quad q_2 \quad q_3 \quad q_4]$$

$$N = \begin{bmatrix} N_1 & 0 & N_2 & 0 \\ 0 & N_1 & 0 & N_2 \end{bmatrix}$$

$$N_1 = \frac{1-\xi}{2} \quad N_2 = \frac{1+\xi}{2}$$

in which ξ is defined from -1 to +1. Then

$$m^e = \frac{\rho A_e \ell_e}{6} \begin{bmatrix} 2 & 0 & 1 & 0 \\ 0 & 2 & 0 & 1 \\ 1 & 0 & 2 & 0 \\ 0 & 1 & 0 & 2 \end{bmatrix}$$

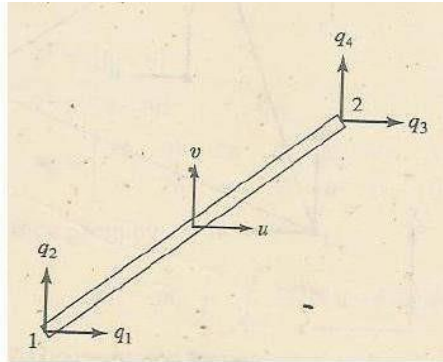

CST element For the plane stress and plane strain conditions for the CST element

$$u^T = [u \quad v]$$

$$q^T = [q_1 \quad q_2 \quad \dots \quad q_6]$$

$$N = \begin{bmatrix} N_1 & 0 & N_2 & 0 & N_3 & 0 \\ 0 & N_1 & 0 & N_2 & 0 & N_3 \end{bmatrix}$$

The element mass matrix is then given by

$$m^e = \rho t_e \int_e N^T N \, dA$$

Noting that $\int_e N_1^2 \, dA = \frac{1}{6} A_e$, $\int_e N_1 N_2 \, dA = \frac{1}{12} A_e$, etc., we have

$$m^e = \frac{\rho t_e A_e}{12} \begin{bmatrix} 2 & 0 & 1 & 0 & 1 & 0 \\ & 2 & 0 & 1 & 0 & 1 \\ & & 2 & 0 & 1 & 0 \\ & & & 2 & 0 & 1 \\ & & & & 2 & 0 \\ & & & & & 2 \end{bmatrix}$$

Symmetric

Lumped mass matrices Practicing engineers also use lumped mass techniques, where the total element mass in each direction is distributed equally to the nodes of the element, and the masses are associated with translational degrees of freedom only. For the truss element, the lumped mass approach gives a mass matrix of

$$m^e = \frac{\rho A_e \ell_e}{2} \begin{bmatrix} 1 & 0 & 0 & 0 \\ & 1 & 0 & 0 \\ & & 1 & 0 \\ & & & 1 \end{bmatrix}$$

Symmetric

For the beam element, the lumped element mass matrix is

$$m^e = \frac{\rho A_e \ell_e}{2} \begin{bmatrix} 1 & 0 & 0 & 0 \\ & 0 & 0 & 0 \\ & & 1 & 0 \\ \text{Symmetric} & & & 0 \end{bmatrix}$$

EVALUATION OF EIGENVALUES AND EIGENVECTORS

$$KU = \lambda MU$$

We observe here that K and M are symmetric matrices. Further, K is positive definite for properly constrained problems.

Properties of Eigenvectors

For a positive definite symmetric stiffness matrix of size n , there are n real eigenvalues and corresponding eigenvectors. The eigenvalues may be arranged in ascending order:

$$0 \leq \lambda_1 \leq \lambda_2 \leq \dots \leq \lambda_n$$

If $U_1, U_2 \dots U_n$ are the corresponding eigenvectors, we have

$$KU_i = \lambda_i MU_i$$

The eigenvectors possess the property of being orthogonal with respect to both the stiffness and mass matrices

$$U_i^T KU_j = 0 \quad \text{if } i \neq j$$

$$U_i^T MU_j = 0 \quad \text{if } i \neq j$$

The lengths of eigenvectors are generally normalized so that

$$U_i^T MU_i = 1$$

The foregoing normalization of the eigenvectors leads to the relation

$$U_i^T KU_i = \lambda_i$$

EIGENVALUE – EIGENVECTOR EVALUATION

The eigenvalue-eigenvector evaluation procedures fall into the following basic categories:

1. Characteristic polynomial technique
2. Vector iteration methods
3. Transformation methods

Characteristic polynomial

$$(K - \lambda M)U = 0$$

If the eigenvector is to be nontrivial, the required condition is

$$\det(K - \lambda M) = 0$$

This represents the characteristic polynomial in λ .

2. Evaluate, $I = \int_{-1}^1 \left[3e^x + x^2 + \frac{1}{x+2} \right] dx$, using one point and two point Gaussian quadrature. Compare with exact solution.

3. For the isoparametric quadrilateral element shown in figure, determine the local co-ordinates of the point P which has Cartesian co-ordinates (7, 4).

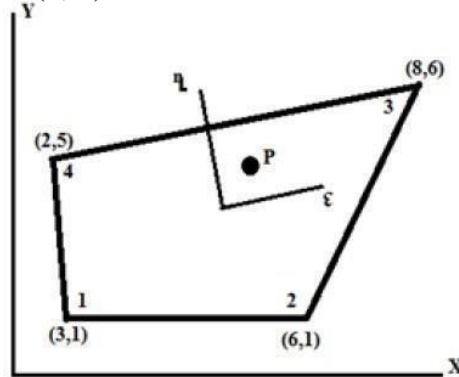

4. A four noded rectangular element is in figure. Determine (i) Jacobian matrix, (ii) Strain – Displacement matrix and (iii) Element Stresses. Take $E=2 \times 10^5 \text{ N/mm}^2, \nu=0.25$,

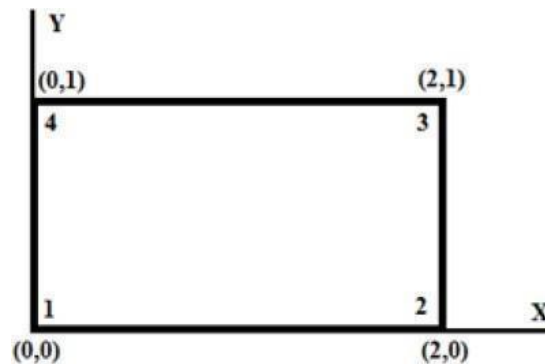

$u = [0, 0, 0.003, 0.004, 0.006, 0.004, 0, 0]^T$, $\epsilon = 0$, $\eta = 0$. Assume plane stress condition.