

MALLA REDDY COLLEGE OF ENGINEERING AND TECHNOLOGY

II Year B.Tech. ECE-II Sem

L/T/P/C

3/-/-/3

(R22A0405) ELECTROMAGNETIC FIELDS & TRANSMISSION LINES**OBJECTIVES**

The course objectives are:

The course objectives are:

1. To introduce the student to the coordinate system and its implementation to electromagnetics.
2. To elaborate the concept of electromagnetic waves and transmission lines, and their practical applications.
3. To study the propagation, reflection, and transmission of plane waves in bounded unbounded media.
4. To present the concepts of transmission lines, and this is a prerequisite course for "Antennas"

UNIT - I:

Electrostatics: Review of coordinate system, Coulomb's Law, Electric Field Intensity - Fields due to Different Charge Distributions, Electric Flux Density, Gauss Law and Applications, Electric Potential, Relations Between E and V, Maxwell's Equations for Electrostatic Fields, Continuity Equation, Relaxation Time, Poisson's and Laplace's Equations Illustrative Problems.

UNIT - II:

Magnetostatics: Biot - Savart's Law, Ampere's Circuital Law and Applications, Magnetic Flux Density, Maxwell's Equations for Magnetostatic Fields, Magnetic Scalar and Vector Potentials, Forces due to Magnetic Fields, Ampere's Force Law.

Maxwell's Equations (Time Varying Fields): Faraday's Law, Inconsistency of Ampere's Law and Displacement Current Density, Maxwell's Equations in Different Final Forms, Conditions at a Boundary Surface: Dielectric - Dielectric, Illustrative Problems.

UNIT - III:

EM Wave Characteristics: Wave Equations for Conducting and Perfect Dielectric Media, Uniform Plane Waves - Definition, All Relations Between E & H, Reflection and Refraction of Plane Waves - Normal for both perfect Conductor and perfect Dielectrics, Brewster Angle, Critical Angle and Total Internal Reflection, Poynting Vector and Poynting Theorem, Illustrative Problems.

UNIT - IV:

Transmission Lines - I: Types, Parameters, Transmission Line Equations, Primary & Secondary Constants, Expressions for Characteristics Impedance, Propagation Constant, Phase and Group Velocities, Infinite Line Concepts, , Distortion - Condition for Distortion less Transmission and Minimum Attenuation, Illustrative Problems.

UNIT - V:

Transmission Lines - II: SC and OC Lines, Input Impedance Relations, Reflection Coefficient, VSWR, Smith Chart - Configuration and Applications, Illustrative Problems.

TEXT BOOKS:

1. Elements of Electromagnetics - Matthew N. O. Sadiku, 4th., Oxford Univ. Press.
2. Electromagnetic Waves and Radiating Systems - E.C. Jordan and K. G. Balmain, 2nd Ed., 2000, PHI.
3. Engineering Electromagnetic - William H. Hay Jr. and John A. Buck, 7thEd., 2006, TMH

REFERENCES BOOKS:

1. Engineering Electromagnetics - Nathan Ida, 2ndEd., 2005, Springer (India) Pvt. Ltd., New Delhi.
2. Electromagnetic Waves and Transmission Lines-Y Mallikarjuna Reddy, University Press.
3. Electromagnetic Fields Theory and Transmission Lines - G. Dashibhushana Rao, Wiley India, 2013.
4. Networks, Lines and Fields - John D. Ryder, 2nd Ed., 1999, PHI.

COURSE OUTCOMES:

Upon the successful completion of the course, students will be able to;

1. Study time varying Maxwell equations and their applications in electromagnetic problems.
2. Determine the relationship between time varying electric and magnetic field and electromotive force.
3. Analyze basic transmission line parameters in phasor domain.
4. Use Maxwell equation to describe the propagation of electromagnetic waves in vacuum.
5. Show how waves propagate in dielectrics and lossy media.
6. Demonstrate the reflection and refraction of waves at boundaries.
7. Explain the basic wave guide operation and parameters.

UNIT – I

ELECTROSTATICS

Contents

- Review of coordinate system
- Coulomb's Law
- Electric Field Intensity - Fields due to Different Charge Distributions
- Electric Flux Density
- Gauss Law and Applications
- Electric Potential
- Relations Between E and V
- Maxwell's Equations for Electrostatic Fields
- Continuity Equation
- Relaxation Time
- Poisson's and Laplace's Equations
- Illustrative Problems.

Introduction:

Electrostatics, as the name implies, is the study of stationary electric charges. Electrostatics is the study of electric charges at rest. It involves the interaction between charged particles and the forces and fields they create. Coulomb's law is a fundamental principle in electrostatics that describes the force between two-point charges.

Vector Algebra is a part of algebra that deals with the theory of vectors and vector spaces.

Most of the physical quantities are either scalar or vector quantities.

Scalar Quantity:

Scalar is a number that defines magnitude. Hence a scalar quantity is defined as a quantity that has magnitude only. A scalar quantity does not point to any direction i.e. a scalar quantity has no directional component.

For example, when we say, the temperature of the room is 30° C, we don't specify the direction.

Hence examples of scalar quantities are mass, temperature, volume, speed etc.

A scalar quantity is represented simply by a letter – A, B, T, V, S.

Vector Quantity:

A Vector has both a magnitude and a direction. Hence a vector quantity is a quantity that has both magnitude and direction.

Examples of vector quantities are force, displacement, velocity, etc.

$$\vec{A}, \vec{V}, \vec{B}, \vec{F}$$

A vector quantity is represented by a letter with an arrow over it or a bold letter.

Unit Vectors:

When a simple vector is divided by its own magnitude, a new vector is created known as the unit vector. A unit vector has a magnitude of one. Hence the name - unit vector.

A unit vector is always used to describe the direction of respective vector.

$$\mathbf{a}_A = \frac{\vec{A}}{|\mathbf{A}|} \Rightarrow \vec{A} = |\mathbf{A}| \mathbf{a}_A$$

Hence any vector can be written as the product of its magnitude and its unit vector. Unit Vectors along the co-ordinate directions are referred to as the base vectors. For example unit vectors along X, Y and Z directions are a_x , a_y and a_z respectively.

Position Vector / Radius Vector (\overline{OP}):

A Position Vector / Radius vector define the position of a point(P) in space relative to the origin(O). Hence Position vector is another way to denote a point in space.

$$\overline{OP} = x\overline{a}_x + y\overline{a}_y + z\overline{a}_z$$

Displacement Vector

Displacement Vector is the displacement or the shortest distance from one point to another.

Vector Multiplication

When two vectors are multiplied the result is either a scalar or a vector depending on how they are multiplied. The two important types of vector multiplication are:

- Dot Product/Scalar Product (A.B)
- Cross product (A x B)

1. DOT PRODUCT (A. B):

Dot product of two vectors A and B is defined as:

$$\overline{A} \cdot \overline{B} = |\overline{A}| |\overline{B}| \cos \theta_{AB}$$

Where θ_{AB} is the angle formed between A and B.

Also θ_{AB} ranges from 0 to π i.e. $0 \leq \theta_{AB} \leq \pi$

The result of A.B is a scalar, hence dot product is also known as Scalar Product.

Properties of Dot Product:

1. If $A = (A_x, A_y, A_z)$ and $B = (B_x, B_y, B_z)$ then

$$\overline{A} \cdot \overline{B} = A_x B_x + A_y B_y + A_z B_z$$

2. $\overline{A} \cdot \overline{B} = |A| |B|$, if $\cos \theta_{AB} = 1$ which means $\theta_{AB} = 0^\circ$

This shows that A and B are in the same direction or we can also say that A and B are parallel to each other.

3. $\overline{A} \cdot \overline{B} = -|A| |B|$, if $\cos \theta_{AB} = -1$ which means $\theta_{AB} = 180^\circ$.

This shows that A and B are in the opposite direction or we can also say that A and B are antiparallel to each other.

4. $\overline{A} \cdot \overline{B} = 0$, if $\cos \theta_{AB} = 0$ which means $\theta_{AB} = 90^\circ$.

This shows that A and B are orthogonal or perpendicular to each other.

5. Since we know the Cartesian base vectors are mutually perpendicular to each other, we have

$$\overline{a}_x \cdot \overline{a}_x = \overline{a}_y \cdot \overline{a}_y = \overline{a}_z \cdot \overline{a}_z = 1 \quad \text{and} \quad \overline{a}_x \cdot \overline{a}_y = \overline{a}_y \cdot \overline{a}_z = \overline{a}_z \cdot \overline{a}_x = 0$$

2. Cross Product (A X B):

Cross Product of two vectors A and B is given as:

$$\vec{A} \times \vec{B} = |\vec{A}| |\vec{B}| \sin \theta_{AB} \vec{a}_N$$

Where θ_{AB} is the angle formed between A and B and \vec{a}_N is a unit vector normal to both A and B. Also θ ranges from 0 to π i.e. $0 \leq \theta_{AB} \leq \pi$

The cross product is an operation between two vectors and the output is also a vector.

Properties of Cross Product:

1. If $A = (A_x, A_y, A_z)$ and $B = (B_x, B_y, B_z)$ then,

$$\mathbf{A} * \mathbf{B} = \begin{vmatrix} \mathbf{a}_x & \mathbf{a}_y & \mathbf{a}_z \\ A_x & A_y & A_z \\ B_x & B_y & B_z \end{vmatrix}$$

The resultant vector is always normal to both the vector A and B.

2. $\vec{A} \times \vec{B} = 0$, if $\sin \theta_{AB} = 0$ which means $\theta_{AB} = 0^\circ$ or 180° ;
This shows that A and B are either parallel or antiparallel to each other.

3. $\vec{A} \times \vec{B} = |\vec{A}| |\vec{B}| \vec{a}_N$, if $\sin \theta_{AB} = 1$ which means $\theta_{AB} = 90^\circ$.
This shows that A and B are orthogonal or perpendicular to each other.

4. Since we know the Cartesian base vectors are mutually perpendicular to each other, we have

$$\vec{a}_x \times \vec{a}_x = \vec{a}_y \times \vec{a}_y = \vec{a}_z \times \vec{a}_z = 0$$

$$\vec{a}_x \times \vec{a}_y = \vec{a}_z, \vec{a}_y \times \vec{a}_z = \vec{a}_x, \vec{a}_z \times \vec{a}_x = \vec{a}_y$$

CO-ORDINATE SYSTEMS:

Co-Ordinate system is a system of representing points in a space of given dimensions by coordinates, such as the Cartesian coordinate system or the system of celestial longitude and latitude.

In order to describe the spatial variations of the quantities, appropriate coordinate system is required. A point or vector can be represented in a curvilinear coordinate system that may be orthogonal or non-orthogonal. An orthogonal system is one in which the coordinates are mutually perpendicular to each other.

The different co-ordinate system available are:

- Cartesian or Rectangular co-ordinate system. (Example: Cube, Cuboid)
- Circular Cylindrical co-ordinate system. (Example: Cylinder)
- Spherical co-ordinate system. (Example: Sphere)

The choice depends on the geometry of the application.

A set of 3 scalar values that define position and a set of unit vectors that define direction form a co-ordinate system. The 3 scalar values used to define position are called co-ordinates. All coordinates are defined with respect to an arbitrary point called the origin.

1. Cartesian Co-ordinate System / Rectangular Co-ordinate System (x,y,z)

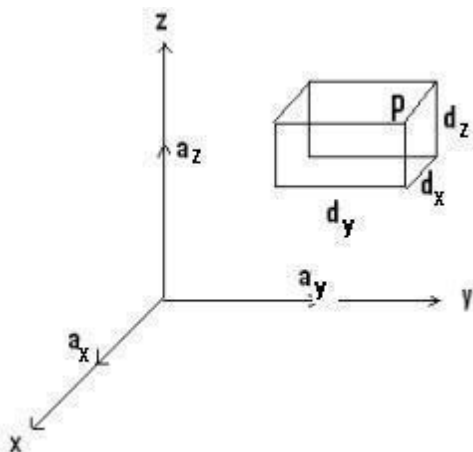

A Vector in Cartesian system is represented as (A_x, A_y, A_z) Or

$$\bar{A} = A_x \bar{a}_x + A_y \bar{a}_y + A_z \bar{a}_z$$

Where \bar{a}_x, \bar{a}_y and \bar{a}_z are the unit vectors in x, y, z direction respectively

Range of the variables:

It defines the minimum and the maximum value that x, y and z can have in Cartesian system.

$$-\infty \leq x, y, z \leq \infty$$

Differential Displacement / Differential Length (dl):

It is given as

$$\bar{dl} = dx\bar{a}_x + dy\bar{a}_y + dz\bar{a}_z$$

Differential length for a line parallel to x, y and z axis are respectively given as:

$$dl = dx\bar{a}_x \text{---(For a line parallel to x-axis).}$$

$$dl = dy\bar{a}_y \text{---(For a line Parallel to y-axis).}$$

$$dl = dz\bar{a}_z \text{---(For a line parallel to z-axis).}$$

If there is a wire of length L in z-axis, then the differential length is given as $dl = dz \bar{a}_z$.

Similarly, if the wire is in y-axis, then the differential length is given as $dl = dy \bar{a}_y$.

Differential Normal Surface (ds):

Differential surface is basically a cross product between two parameters of the surface.

The differential surface (area element) is defined as

$$\bar{ds} = ds\bar{a}_N$$

Where \bar{a}_N , is the unit vector perpendicular to the surface.

For the 1st figure,

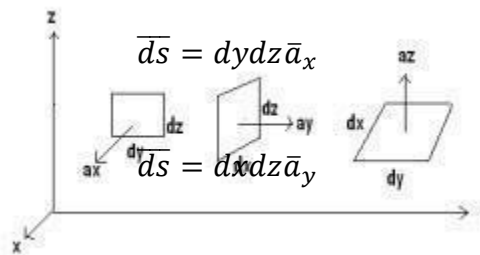

2nd figure,

3rd figure,

$$\bar{ds} = dx dy \bar{a}_z$$

Differential Volume:

The differential volume element (dv) can be expressed in terms of the triple product.

$$dv = dx dy dz$$

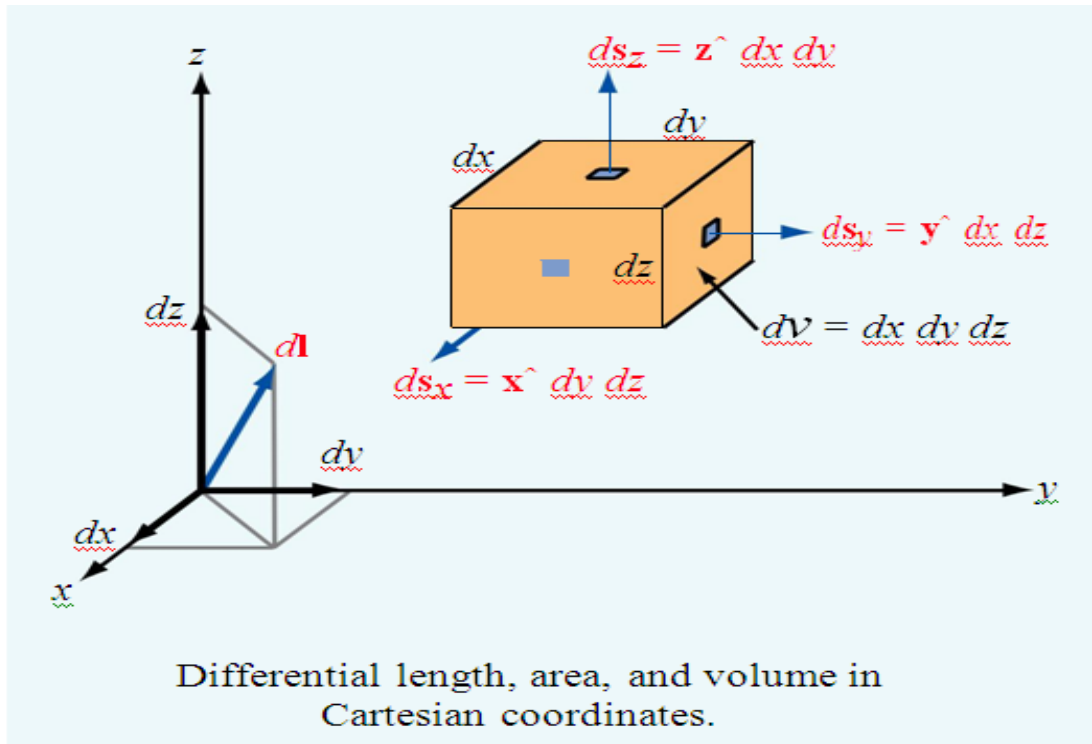

2. Circular Cylindrical Co-ordinate System

A Vector in Cylindrical system is represented as (A_r, A_ϕ, A_z) or

$$\vec{A} = A_r \vec{a}_r + A_\phi \vec{a}_\phi + A_z \vec{a}_z$$

Where \vec{a}_r , \vec{a}_ϕ and \vec{a}_z are the unit vectors in r , Φ and z directions respectively.

The physical significance of each parameter of cylindrical coordinates:

1. The value r indicates the distance of the point from the z -axis. It is the radius of the cylinder.
2. The value Φ , also called the azimuthal angle, indicates the rotation angle around the z -axis. It is basically measured from the x axis in the x - y plane. It is measured anti clockwise.
3. The value z indicates the distance of the point from z -axis. It is the same as in the Cartesian system. In short, it is the height of the cylinder.

Range of the variables:

It defines the minimum and the maximum values of r , Φ and z .

$$0 \leq r \leq \infty$$

$$0 \leq \Phi \leq 2\pi$$

$$-\infty \leq z \leq \infty$$

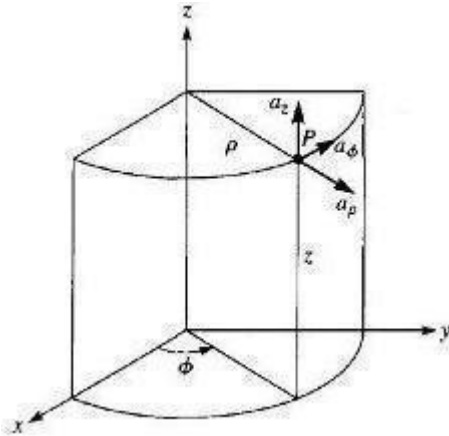

Figure shows Point P and Unit vectors in Cylindrical Co-ordinate System.

Differential Displacement / Differential Length (dl):

It is given as

$$\bar{dl} = dr\bar{a}_r + r d\phi\bar{a}_\phi + dz\bar{a}_z$$

Differential length for a line parallel to r, Φ and z axis are respectively given as:

$$dl = dr\bar{a}_r \text{---(For a line parallel to r-direction).}$$

$$dl = r d\phi\bar{a}_\phi \text{---(For a line Parallel to } \Phi\text{-direction).}$$

$$dl = dz\bar{a}_z \text{---(For a line parallel to z-axis).}$$

Differential Normal Surface (ds):

Differential surface is basically a cross product between two parameters of the surface.

The differential surface (area element) is defined as

$$\bar{ds} = ds\bar{a}_N$$

Where \bar{a}_N , is the unit vector perpendicular to the surface.

This surface describes a circular disc. Always remember- To define a circular disk we need two parameter one distance measure and one angular measure. An angular parameter will always give a curved line or an arc.

In this case $d\Phi$ is measured in terms of change in arc. Arc is given as:

Arc= radius * angle

$$\bar{ds} = r dr d\phi \bar{a}_z$$

$$\bar{ds} = r dr dz \bar{a}_\phi$$

$$\bar{ds} = r dr d\phi \bar{a}_r$$

Differential Volume:

The differential volume element (dv) can be expressed in terms of the triple product.

$$dv = r dr d\phi dz$$

3. Spherical coordinate System:

Spherical coordinates consist of one scalar value (r), with units of distance, while the other two scalar values (θ , Φ) have angular units (degrees or radians).

A Vector in Spherical System is represented as (A_r, A_θ, A_Φ) or

$$\vec{A} = A_r \vec{a}_r + A_\theta \vec{a}_\theta + A_\Phi \vec{a}_\Phi$$

Where $\vec{a}_r, \vec{a}_\theta$ and \vec{a}_Φ are the unit vectors in r, θ and Φ direction respectively.

The physical significance of each parameter of spherical coordinates:

1. The value r expresses the distance of the point from origin (i.e. similar to altitude). It is the radius of the sphere.
2. The angle θ is the angle formed with the z -axis (i.e. similar to latitude). It is also called the co-latitude angle. It is measured clockwise.
3. The angle Φ , also called the azimuthal angle, indicates the rotation angle around the z -axis (i.e. similar to longitude). It is basically measured from the x axis in the x - y plane. It is measured counter-clockwise.

Range of the variables:

It defines the minimum and the maximum value that r, θ and Φ can have in spherical co-ordinate system.

$$\begin{aligned} 0 &\leq r \leq \infty \\ 0 &\leq \theta \leq \pi \\ 0 &\leq \Phi \leq 2\pi \end{aligned}$$

Differential length:

It is given as

$$d\vec{l} = dr \vec{a}_r + r d\theta \vec{a}_\theta + r \sin \theta d\Phi \vec{a}_\Phi$$

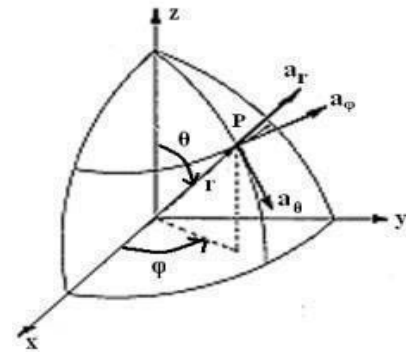

Differential length for a line parallel to r, θ and Φ axis are respectively given as:

$$dl = dr \vec{a}_r \text{---(For a line parallel to } r \text{ axis)}$$

$$dl = r d\theta \vec{a}_\theta \text{---(For a line parallel to } \theta \text{ direction)}$$

$$dl = r \sin \theta d\Phi \vec{a}_\Phi \text{---(For a line parallel to } \Phi \text{ direction)}$$

Differential Normal Surface (ds): Differential surface is basically a cross product between two parameters of the surface.

The differential surface (area element) is defined as

$$d\vec{s} = ds \vec{a}_N$$

Where \vec{a}_N , is the unit vector perpendicular to the surface.

$$\begin{aligned} d\vec{s} &= r dr d\theta \vec{a}_\Phi \\ d\vec{s} &= r^2 \sin \theta d\Phi d\theta \vec{a}_r \end{aligned}$$

$$\overline{ds} = r \sin \theta \, dr d\phi \overline{a}_\theta$$

Differential Volume:

The differential volume element (dv) can be expressed in terms of the triple product.

$$dv = r^2 \sin \theta \, dr d\phi d\theta$$

Coordinate transformations:

Coordinate transformations

Transformation	Coordinate Variables	Unit Vectors	Vector Components
Cartesian to cylindrical	$r = \sqrt{x^2 + y^2}$ $\phi = \tan^{-1}(y/x)$ $z = z$	$\hat{r} = \hat{x} \cos \phi + \hat{y} \sin \phi$ $\hat{\phi} = -\hat{x} \sin \phi + \hat{y} \cos \phi$ $\hat{z} = \hat{z}$	$A_r = A_x \cos \phi + A_y \sin \phi$ $A_\phi = -A_x \sin \phi + A_y \cos \phi$ $A_z = A_z$
Cylindrical to Cartesian	$x = r \cos \phi$ $y = r \sin \phi$ $z = z$	$\hat{x} = \hat{r} \cos \phi - \hat{\phi} \sin \phi$ $\hat{y} = \hat{r} \sin \phi + \hat{\phi} \cos \phi$ $\hat{z} = \hat{z}$	$A_x = A_r \cos \phi - A_\phi \sin \phi$ $A_y = A_r \sin \phi + A_\phi \cos \phi$ $A_z = A_z$
Cartesian to spherical	$R = \sqrt{x^2 + y^2 + z^2}$ $\theta = \tan^{-1}[\sqrt{x^2 + y^2}/z]$ $\phi = \tan^{-1}(y/x)$	$\hat{R} = \hat{x} \sin \theta \cos \phi + \hat{y} \sin \theta \sin \phi + \hat{z} \cos \theta$ $\hat{\theta} = \hat{x} \cos \theta \cos \phi + \hat{y} \cos \theta \sin \phi - \hat{z} \sin \theta$ $\hat{\phi} = -\hat{x} \sin \phi + \hat{y} \cos \phi$	$A_R = A_x \sin \theta \cos \phi + A_y \sin \theta \sin \phi + A_z \cos \theta$ $A_\theta = A_x \cos \theta \cos \phi + A_y \cos \theta \sin \phi - A_z \sin \theta$ $A_\phi = -A_x \sin \phi + A_y \cos \phi$
Spherical to Cartesian	$x = R \sin \theta \cos \phi$ $y = R \sin \theta \sin \phi$ $z = R \cos \theta$	$\hat{x} = \hat{R} \sin \theta \cos \phi + \hat{\theta} \cos \theta \cos \phi - \hat{\phi} \sin \phi$ $\hat{y} = \hat{R} \sin \theta \sin \phi + \hat{\theta} \cos \theta \sin \phi + \hat{\phi} \cos \phi$ $\hat{z} = \hat{R} \cos \theta - \hat{\theta} \sin \theta$	$A_x = A_R \sin \theta \cos \phi + A_\theta \cos \theta \cos \phi - A_\phi \sin \phi$ $A_y = A_R \sin \theta \sin \phi + A_\theta \cos \theta \sin \phi + A_\phi \cos \phi$ $A_z = A_R \cos \theta - A_\theta \sin \theta$
Cylindrical to spherical	$R = \sqrt{r^2 + z^2}$ $\theta = \tan^{-1}(r/z)$ $\phi = \phi$	$\hat{R} = \hat{r} \sin \theta + \hat{z} \cos \theta$ $\hat{\theta} = \hat{r} \cos \theta - \hat{z} \sin \theta$ $\hat{\phi} = \hat{\phi}$	$A_R = A_r \sin \theta + A_z \cos \theta$ $A_\theta = A_r \cos \theta - A_z \sin \theta$ $A_\phi = A_\phi$
Spherical to cylindrical	$r = R \sin \theta$ $\phi = \phi$ $z = R \cos \theta$	$\hat{r} = \hat{R} \sin \theta + \hat{\theta} \cos \theta$ $\hat{\phi} = \hat{\phi}$ $\hat{z} = \hat{R} \cos \theta - \hat{\theta} \sin \theta$	$A_r = A_R \sin \theta + A_\theta \cos \theta$ $A_\phi = A_\phi$ $A_z = A_R \cos \theta - A_\theta \sin \theta$

Vector relations in the three common coordinate systems.

	Cartesian Coordinates	Cylindrical Coordinates	Spherical Coordinates
Coordinate variables	x, y, z	r, ϕ, z	R, θ, ϕ
Vector representation $\mathbf{A} =$	$\hat{x}A_x + \hat{y}A_y + \hat{z}A_z$	$\hat{r}A_r + \hat{\phi}A_\phi + \hat{z}A_z$	$\hat{R}A_R + \hat{\theta}A_\theta + \hat{\phi}A_\phi$
Magnitude of A $ \mathbf{A} =$	$\sqrt{A_x^2 + A_y^2 + A_z^2}$	$\sqrt{A_r^2 + A_\phi^2 + A_z^2}$	$\sqrt{A_R^2 + A_\theta^2 + A_\phi^2}$
Position vector $\overrightarrow{OP_1} =$	$\hat{x}x_1 + \hat{y}y_1 + \hat{z}z_1,$ for $P(x_1, y_1, z_1)$	$\hat{r}r_1 + \hat{z}z_1,$ for $P(r_1, \phi_1, z_1)$	$\hat{R}R_1,$ for $P(R_1, \theta_1, \phi_1)$
Base vectors properties	$\hat{x} \cdot \hat{x} = \hat{y} \cdot \hat{y} = \hat{z} \cdot \hat{z} = 1$ $\hat{x} \cdot \hat{y} = \hat{y} \cdot \hat{z} = \hat{z} \cdot \hat{x} = 0$ $\hat{x} \times \hat{y} = \hat{z}$ $\hat{y} \times \hat{z} = \hat{x}$ $\hat{z} \times \hat{x} = \hat{y}$	$\hat{r} \cdot \hat{r} = \hat{\phi} \cdot \hat{\phi} = \hat{z} \cdot \hat{z} = 1$ $\hat{r} \cdot \hat{\phi} = \hat{\phi} \cdot \hat{z} = \hat{z} \cdot \hat{r} = 0$ $\hat{r} \times \hat{\phi} = \hat{z}$ $\hat{\phi} \times \hat{z} = \hat{r}$ $\hat{z} \times \hat{r} = \hat{\phi}$	$\hat{R} \cdot \hat{R} = \hat{\theta} \cdot \hat{\theta} = \hat{\phi} \cdot \hat{\phi} = 1$ $\hat{R} \cdot \hat{\theta} = \hat{\theta} \cdot \hat{\phi} = \hat{\phi} \cdot \hat{R} = 0$ $\hat{R} \times \hat{\theta} = \hat{\phi}$ $\hat{\theta} \times \hat{\phi} = \hat{R}$ $\hat{\phi} \times \hat{R} = \hat{\theta}$
Dot product $\mathbf{A} \cdot \mathbf{B} =$	$A_x B_x + A_y B_y + A_z B_z$	$A_r B_r + A_\phi B_\phi + A_z B_z$	$A_R B_R + A_\theta B_\theta + A_\phi B_\phi$
Cross product $\mathbf{A} \times \mathbf{B} =$	$\begin{vmatrix} \hat{x} & \hat{y} & \hat{z} \\ A_x & A_y & A_z \\ B_x & B_y & B_z \end{vmatrix}$	$\begin{vmatrix} \hat{r} & \hat{\phi} & \hat{z} \\ A_r & A_\phi & A_z \\ B_r & B_\phi & B_z \end{vmatrix}$	$\begin{vmatrix} \hat{R} & \hat{\theta} & \hat{\phi} \\ A_R & A_\theta & A_\phi \\ B_R & B_\theta & B_\phi \end{vmatrix}$
Differential length $d\mathbf{l} =$	$\hat{x} dx + \hat{y} dy + \hat{z} dz$	$\hat{r} dr + \hat{\phi} r d\phi + \hat{z} dz$	$\hat{R} dR + \hat{\theta} R d\theta + \hat{\phi} R \sin\theta d\phi$
Differential surface areas	$ds_x = \hat{x} dy dz$ $ds_y = \hat{y} dx dz$ $ds_z = \hat{z} dx dy$	$ds_r = \hat{r} r d\phi dz$ $ds_\phi = \hat{\phi} dr dz$ $ds_z = \hat{z} r dr d\phi$	$ds_R = \hat{R} R^2 \sin\theta d\theta d\phi$ $ds_\theta = \hat{\theta} R \sin\theta dR d\phi$ $ds_\phi = \hat{\phi} R dR d\theta$
Differential volume $dV =$	$dx dy dz$	$r dr d\phi dz$	$R^2 \sin\theta dR d\theta d\phi$

Del operator:

Del is a vector differential operator. The del operator will be used in for differential operations throughout any course on field theory. The following equation is the del operator for different coordinate systems.

$$\nabla = \frac{\partial}{\partial x} \hat{a}_x + \frac{\partial}{\partial y} \hat{a}_y + \frac{\partial}{\partial z} \hat{a}_z = \nabla_{x,y,z}$$

$$\nabla = \frac{\partial}{\partial \rho} \hat{a}_\rho + \frac{1}{\rho} \frac{\partial}{\partial \phi} \hat{a}_\phi + \frac{\partial}{\partial z} \hat{a}_z$$

$$\nabla = \frac{\partial}{\partial r} \hat{a}_r + \frac{1}{r} \frac{\partial}{\partial \theta} \hat{a}_\theta + \frac{1}{r \sin \theta} \frac{\partial}{\partial \phi} \hat{a}_\phi$$

Gradient of a Scalar:

• The gradient of a scalar field, V , is a vector that represents both the magnitude and the direction of the maximum space rate of increase of V .

$$\nabla V = \frac{\partial V}{\partial x} \hat{a}_x + \frac{\partial V}{\partial y} \hat{a}_y + \frac{\partial V}{\partial z} \hat{a}_z = \nabla V_{x,y,z}$$

• To help visualize this concept, take for example a topographical map. Lines on the map represent equal magnitudes of the scalar field. The gradient vector crosses map at the location where the lines packed into the most dense space and perpendicular (or normal) to them. The orientation (up or down) of the gradient vector is such that the field is increased in magnitude along that direction.

-Fundamental properties of the gradient of a scalar field

- The magnitude of gradient equals the maximum rate of change in V per unit distance
- Gradient points in the direction of the maximum rate of change in V
- Gradient at any point is perpendicular to the constant V surface that passes through that point
- The projection of the gradient in the direction of the unit vector \mathbf{a} , is

$$\nabla V \cdot \hat{a}$$

- and is called the directional derivative of V along \mathbf{a} . This is the rate of change of V in the direction of \mathbf{a} .
- If \mathbf{A} is the gradient of V , then V is said to be the scalar potential of \mathbf{A} .

Divergence of a Vector:

The divergence of a vector, \mathbf{A} , at any given point P is the outward flux per unit volume as volume shrinks about P .

$$\text{div} \vec{A} = \nabla \cdot \vec{A} = \lim_{\Delta v \rightarrow 0} \frac{\oint_S \vec{A} \cdot d\vec{S}}{\Delta v}$$

The divergence of a vector field is a scalar field. The divergence is generally denoted by “div”. The divergence of a vector field can be calculated by taking the scalar product of the vector operator applied to the vector field

$$\nabla \cdot \vec{A} = \frac{\partial A_x}{\partial x} + \frac{\partial A_y}{\partial y} + \frac{\partial A_z}{\partial z} \longrightarrow \text{Rectangular Coordinate System}$$

$$\nabla \cdot \vec{A} = \frac{1}{\rho} \frac{\partial}{\partial \rho} (\rho A_\rho) + \frac{1}{\rho} \frac{\partial A_\phi}{\partial \phi} + \frac{\partial A_z}{\partial z} \longrightarrow \text{Cylindrical Coordinate System}$$

$$\nabla \cdot \vec{A} = \frac{1}{r^2} \frac{\partial}{\partial r} (r^2 A_r) + \frac{1}{r \sin \theta} \frac{\partial}{\partial \theta} (A_\theta \sin \theta) + \frac{1}{r \sin \theta} \frac{\partial A_\phi}{\partial \phi}$$

Spherical Coordinate System

Curl of a Vector:

The curl of a vector, \mathbf{A} is an axial vector whose magnitude is the maximum circulation of \mathbf{A} per unit area as the area tends to zero and whose direction is the normal direction of the area when the area is oriented to make the circulation maximum.

-Curl of a vector in each of the three primary coordinate systems are,

Cartesian
$$\nabla \times \vec{A} = \begin{vmatrix} \hat{a}_x & \hat{a}_y & \hat{a}_z \\ \frac{\partial}{\partial x} & \frac{\partial}{\partial y} & \frac{\partial}{\partial z} \\ A_x & A_y & A_z \end{vmatrix} = \left[\frac{\partial A_z}{\partial y} - \frac{\partial A_y}{\partial z} \right] \hat{a}_x - \left[\frac{\partial A_z}{\partial x} - \frac{\partial A_x}{\partial z} \right] \hat{a}_y + \left[\frac{\partial A_y}{\partial x} - \frac{\partial A_x}{\partial y} \right] \hat{a}_z$$

Cylindrical
$$\nabla \times \vec{A} = \frac{1}{\rho} \begin{vmatrix} \hat{a}_\rho & \rho \hat{a}_\phi & \hat{a}_z \\ \frac{\partial}{\partial \rho} & \frac{\partial}{\partial \phi} & \frac{\partial}{\partial z} \\ A_\rho & \rho A_\phi & A_z \end{vmatrix} = \left[\frac{1}{\rho} \frac{\partial A_z}{\partial \phi} - \frac{\partial A_\phi}{\partial z} \right] \hat{a}_\rho - \left[\frac{\partial A_z}{\partial \rho} - \frac{\partial A_\rho}{\partial z} \right] \hat{a}_\phi + \frac{1}{\rho} \left[\frac{\partial(\rho A_\phi)}{\partial \rho} - \frac{\partial A_\rho}{\partial \phi} \right] \hat{a}_z$$

Spherical
$$\nabla \times \vec{A} = \frac{1}{r^2 \sin \theta} \begin{vmatrix} \hat{a}_r & r \hat{a}_\theta & r \sin \theta \hat{a}_\phi \\ \frac{\partial}{\partial r} & \frac{\partial}{\partial \theta} & \frac{\partial}{\partial \phi} \\ A_r & r A_\theta & r \sin \theta A_\phi \end{vmatrix}$$

$$\nabla \times \vec{A} = \frac{1}{r \sin \theta} \left[\frac{\partial(A_\phi \sin \theta)}{\partial \theta} - \frac{\partial A_\theta}{\partial \phi} \right] \hat{a}_r - \frac{1}{r} \left[\frac{\partial(r A_\phi)}{\partial r} - \frac{1}{\sin \theta} \frac{\partial A_r}{\partial \phi} \right] \hat{a}_\theta + \frac{1}{r} \left[\frac{\partial(r A_\theta)}{\partial r} - \frac{\partial A_r}{\partial \theta} \right] \hat{a}_\phi$$

Divergence Theorem:

- The divergence theorem states that the total outward flux of a vector field, \mathbf{A} , through the closed surface, S , is the same as the volume integral of the divergence of \mathbf{A} .
- This theorem is easily shown from the equation for the divergence of a vector field.

$$\vec{A} = A_1 \hat{a}_1 + A_2 \hat{a}_2 + A_3 \hat{a}_3$$

$$\text{div} \vec{A} = \nabla \cdot \vec{A} = \lim_{\Delta v \rightarrow 0} \frac{\oint_S \vec{A} \cdot d\vec{S}}{\Delta v}$$

$$\int_V \nabla \cdot \vec{A} dv = \oint_S \vec{A} \cdot d\vec{S}$$

Stokes Theorem:

- Stokes theorem states that the circulation of a vector field \mathbf{A} , around a closed path, L is equal to the surface integral of the curl of \mathbf{A} over the open surface S bounded by L . This theorem has been proven to hold as long as \mathbf{A} and the curl of \mathbf{A} are continuous along the closed surface S of a closed path L .

- This theorem is easily shown from the equation for the curl of a vector field.

$$\vec{A} = A_1\hat{a}_1 + A_2\hat{a}_2 + A_3\hat{a}_3$$

$$\text{curl}\vec{A} = \nabla \times \vec{A} = \left(\lim_{\Delta S \rightarrow 0} \frac{\oint_L \vec{A} \cdot d\vec{l}}{\Delta S} \right)_{\text{max}} \hat{a}_n$$

$$\oint_L \vec{A} \cdot d\vec{l} = \oint_S (\nabla \times \vec{A}) \cdot d\vec{S}$$

Types of Charge Distributions:

Point charge: When size of a body is much smaller than the distance under consideration, then the size of the body may be ignored and the charged body is called point charge.

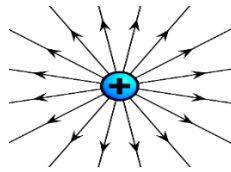

The continuous load distribution system is a system in which the charge is uniformly distributed over the conductor. For a continuous charging device, the infinite number of charges is closely packed and there is no space between them. Unlike the discrete charging system, the continuous load distribution in the conductor is uninterrupted and continuous. There are 3 types of continuous charge distribution system -

- Linear Charge Distribution
- Surface Charge Distribution
- Volume Charge Distribution

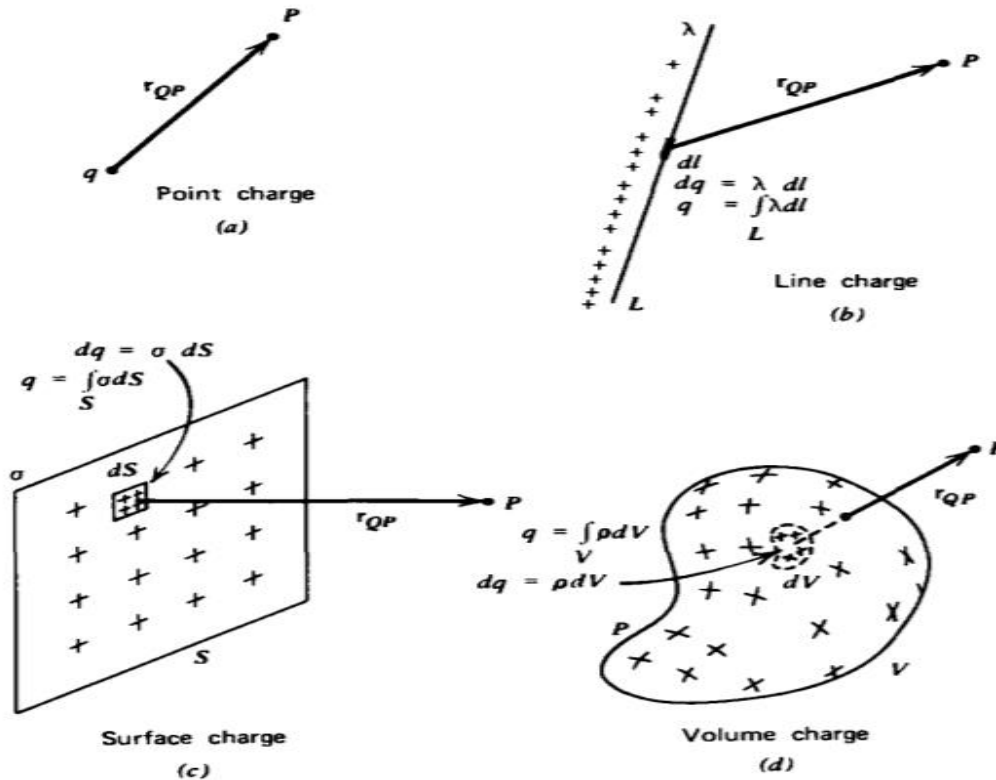

Charge distributions. (a) Point charge; (b) Line charge; (c) Surface charge; (d) Volume charge.

Charge Densities

Volume Charge Density

- When a charge Q is distributed evenly throughout a volume V , the Volume Charge Density is defined as:
 $\rho \equiv (Q/V)$ (Units are C/m^3)

Surface Charge Density

- When a charge Q is distributed evenly over a surface area A , the Surface Charge Density is defined as:
 $\sigma \equiv Q/A$ (Units are C/m^2)

Linear Charge Density

- When a charge Q is distributed along a line ℓ , the Linear Charge Density is defined as:
 $\lambda \equiv (Q/\ell)$ (Units are C/m)

Coulomb's Law

Coulomb's Law states that the force between two-point charges Q_1 and Q_2 is directly proportional to the product of the charges and inversely proportional to the square of the distance between them.

A point charge is a charge that occupies a region of space which is negligibly small compared to the distance between the point charge and any other object.

Point charge is a hypothetical charge located at a single point in space. It is an idealized model of a particle having an electric charge. Mathematically, ,

$$F = \frac{kQ_1Q_2}{R^2} \quad k = \frac{1}{4\pi\epsilon_0}$$

where k is the proportionality constant.

In SI units, Q1 and Q2 are expressed in Coulombs(C) and R is in meters.

Force F is in Newtons (N) and , ϵ_0 is called the permittivity of free space.

(We are assuming the charges are in free space. If the charges are any other dielectric medium, we will use $\epsilon = \epsilon_0 \epsilon_r$ instead where ϵ_r is called the relative permittivity or the dielectric constant of the medium).

Therefore

$$F = \frac{1}{4\pi\epsilon_0} \frac{Q_1Q_2}{R^2} \dots\dots\dots (1)$$

As shown in the Figure 1 let the position vectors of the point charges Q1 and Q2 are given by \vec{r}_1 and \vec{r}_2 . Let \vec{F}_{12} represent the force on Q1 due to charge Q2.

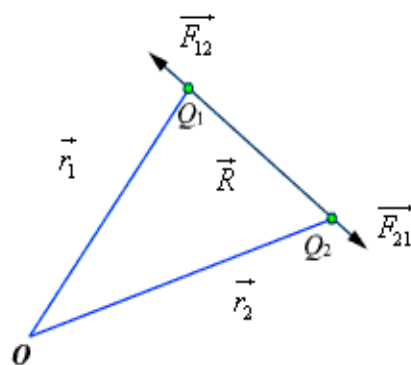

Fig 1: Coulomb's Law

The charges are separated by a distance of $R = |\vec{r}_1 - \vec{r}_2| = |\vec{r}_2 - \vec{r}_1|$. We define the unit vectors as

$$\hat{a}_{12} = \frac{(\vec{r}_2 - \vec{r}_1)}{R} \quad \text{and} \quad \hat{a}_{21} = \frac{(\vec{r}_1 - \vec{r}_2)}{R}$$

\vec{F}_{12} can be defined as

$$\vec{F}_{12} = \frac{Q_1 Q_2}{4\pi\epsilon_0 R^2} \hat{a}_{12} = \frac{Q_1 Q_2}{4\pi\epsilon_0 R^2} \frac{(\vec{r}_2 - \vec{r}_1)}{|\vec{r}_2 - \vec{r}_1|^3}$$

Similarly the force on Q_1 due to charge Q_2 can be calculated and if \vec{F}_{21} represents this force then we can write $\vec{F}_{21} = -\vec{F}_{12}$

When we have a number of point charges, to determine the force on a particular charge due to all other charges, we apply principle of superposition. If we have N number of charges Q_1, Q_2, \dots, Q_N located respectively at the points represented by the position vectors $\vec{r}_1, \vec{r}_2, \dots, \vec{r}_N$, the force experienced by a charge Q located at \vec{r} is given by,

$$\vec{F} = \frac{Q}{4\pi\epsilon_0} \sum_{i=1}^N \frac{Q_i (\vec{r} - \vec{r}_i)}{|\vec{r} - \vec{r}_i|^3}$$

Field:

A field is a function that specifies a particular physical quantity everywhere in a region. Depending upon the nature of the quantity under consideration, the field may be a vector or a scalar field. Example of scalar field is the electrostatic potential in a region while electric or magnetic fields at any point is the example of vector field.

Static Electric Fields:

Electrostatics can be defined as the study of electric charges at rest. Electric fields have their sources in electric charges. The fundamental & experimentally proved laws of electrostatics are Coulomb's law & Gauss's theorem.

Electric Field:

Electric field due to a charge is the space around the unit charge in which it experiences a force. Electric field intensity or the electric field strength at a point is defined as the force per unit charge.

Mathematically,

$$E = F / Q$$

OR

$$F = E Q$$

The force on charge Q is the product of a charge (which is a scalar) and the value of the electric field (which is a vector) at the point where the charge is located. That is

$$\vec{E} = \lim_{Q \rightarrow 0} \frac{\vec{F}}{Q} \quad \text{or,} \quad \vec{E} = \frac{\vec{F}}{Q}$$

The electric field intensity E at a point r (observation point) due a point charge Q located at r' (source point) is given by:

$$\vec{E} = \frac{Q(\vec{r} - \vec{r}')}{4\pi\epsilon_0 |\vec{r} - \vec{r}'|^3}$$

For a collection of N point charges Q_1, Q_2, \dots, Q_N located at r'_1, r'_2, \dots, r'_N , the electric field intensity at point r' is obtained as

$$\vec{E} = \frac{1}{4\pi\epsilon_0} \sum_{i=1}^N \frac{Q_i(\vec{r} - \vec{r}'_i)}{|\vec{r} - \vec{r}'_i|^3}$$

The expression (6) can be modified suitably to compute the electric field due to a continuous distribution of charges.

In figure 2 we consider a continuous volume distribution of charge (t) in the region denoted as the source region.

For an elementary charge $dQ = \rho(\vec{r}')dv'$, i.e. considering this charge as point charge, we can write the field expression as:

$$d\vec{E} = \frac{dQ(\vec{r} - \vec{r}')}{4\pi\epsilon_0 |\vec{r} - \vec{r}'|^3} = \frac{\rho(\vec{r}')dv'(\vec{r} - \vec{r}')}{4\pi\epsilon_0 |\vec{r} - \vec{r}'|^3}$$

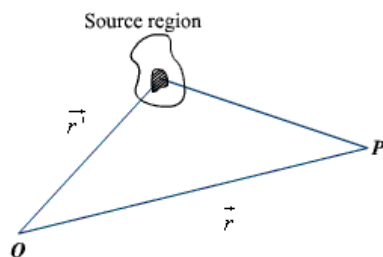

Fig 2: Continuous Volume Distribution of Charge

When this expression is integrated over the source region, we get the electric field at the point P due to this distribution of charges. Thus the expression for the electric field at P can be written as:

$$\vec{E}(\vec{r}) = \int_V \frac{\rho(\vec{r}')(\vec{r} - \vec{r}')}{4\pi\epsilon_0 |\vec{r} - \vec{r}'|^3} dV' \quad \dots\dots\dots \text{volume charge} \dots\dots\dots$$

Similar technique can be adopted when the charge distribution is in the form of a line charge density or a surface charge density.

$$\vec{E}(\vec{r}) = \int_L \frac{\rho_L(\vec{r}')(\vec{r} - \vec{r}')}{4\pi\epsilon_0 |\vec{r} - \vec{r}'|^3} dl' \quad \dots\dots\dots \text{line charge} \dots\dots\dots$$

$$\vec{E}(\vec{r}) = \int_S \frac{\rho_s(\vec{r}')(\vec{r} - \vec{r}')}{4\pi\epsilon_0 |\vec{r} - \vec{r}'|^3} dS' \quad \dots\dots\dots \text{surface charge} \dots\dots\dots$$

Electric Lines of Forces:

Electric line of force is a pictorial representation of the electric field.

Electric line of force (also called Electric Flux lines or Streamlines) is an imaginary straight or curved path along which a unit positive charge tends to move in an electric field.

Properties Of Electric Lines of Force:

1. Lines of force start from positive charge and terminate either at negative charge or move to infinity.
2. Similarly, lines of force due to a negative charge are assumed to start at infinity and terminate at the negative charge.

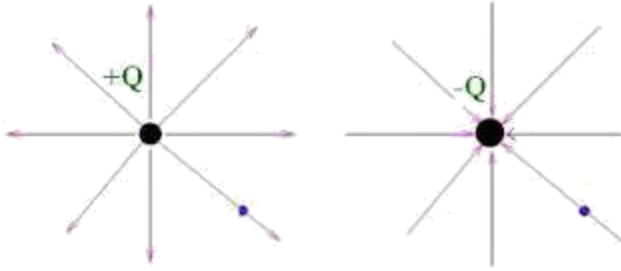

3. The number of lines per unit area, through a plane at right angles to the lines, is proportional to the magnitude of E. This means that, where the lines of force are close together, E is large and where they are far apart E is small.
4. If there is no charge in a volume, then each field line which enters it must also leave it.
5. If there is a positive charge in a volume then more field lines leave it than enter it.
6. If there is a negative charge in a volume then more field lines enter it than leave it.
7. Hence, we say Positive charges are sources and Negative charges are sinks of the field.
8. These lines are independent on medium.
9. Lines of force never intersect i.e. they do not cross each other.
10. Tangent to a line of force at any point gives the direction of the electric field E at that point.

Electric flux density:

As stated earlier electric field intensity or simply 'Electric field' gives the strength of the field at a particular point. The electric field depends on the material media in which the field is being considered. The flux density vector is defined to be independent of the material media (as we'll see that it relates to the charge that is producing it). For a linear isotropic medium under consideration; the flux density vector is defined as:

Electric flux density is defined as the amount of flux passes through unit surface area in the space imagined at right angle to the direction of electric field. The expression of electric field at a point is given by

$$E = \frac{Q}{4\pi\epsilon_0\epsilon_r r^2}$$

Where, Q is the charge of the body by which the field is created. R is the distance of the point from the center of the charged body.

$$\vec{D} = \epsilon \vec{E}$$

We define the electric flux as

$$\psi = \int_S \vec{D} \cdot d\vec{s}$$

Solved problems:

Problem1:

Find the charge in the volume defined by $0 \leq x \leq 1$ m, $0 \leq y \leq 1$ m, and $0 \leq z \leq 1$ m if $\rho = 30x^2y$ ($\mu\text{C}/\text{m}^3$). What change occurs for the limits $-1 \leq y \leq 0$ m?

Since $dQ = \rho dv$,

$$Q = \int_0^1 \int_0^1 \int_0^1 30x^2y dx dy dz = 5 \mu\text{C}$$

For the change in limits on y ,

$$Q = \int_0^1 \int_{-1}^0 \int_0^1 30x^2y dx dy dz = -5 \mu\text{C}$$

Problem-2

Three point charges, $Q_1 = 30$ nC, $Q_2 = 150$ nC, and $Q_3 = -70$ nC, are enclosed by surface S . What net flux crosses S ?

Since **electric** flux was defined as originating **on** positive charge and terminating **on** negative charge, part of the flux from the positive charges terminates **on** the negative charge.

$$\Psi_{\text{net}} = Q_{\text{net}} = 30 + 150 - 70 = 110 \text{ nC}$$

Problem-3

A point charge, $Q = 30$ nC, is located at the origin in cartesian coordinates. Find the **electric** flux density \mathbf{D} at $(1, 3, -4)$ m.

Referring to Fig. 3.12,

$$\begin{aligned} \mathbf{D} &= \frac{Q}{4\pi R^2} \mathbf{a}_R \\ &= \frac{30 \times 10^{-9}}{4\pi(26)} \left(\frac{\mathbf{a}_x + 3\mathbf{a}_y - 4\mathbf{a}_z}{\sqrt{26}} \right) \\ &= (9.18 \times 10^{-11}) \left(\frac{\mathbf{a}_x + 3\mathbf{a}_y - 4\mathbf{a}_z}{\sqrt{26}} \right) \text{ C/m}^2 \end{aligned}$$

or, more conveniently, $D = 91.8$ pC/m².

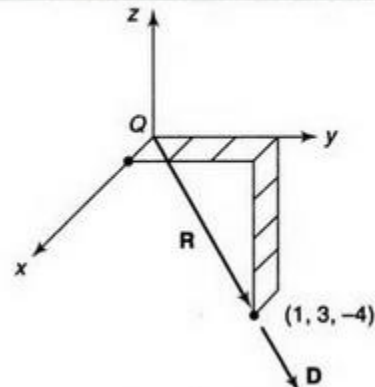

Fig. 3.12

Problem-4

Given that $\mathbf{D} = 10x\mathbf{a}_x$ (C/m²), determine the flux crossing a 1-m² area that is normal to the x axis at $x = 3$ m.

Since \mathbf{D} is constant over the area and perpendicular to it,

$$\Psi = DA = (30 \text{ C/m}^2)(1 \text{ m}^2) = 30 \text{ C}$$

Problem-5

Given the vector field $\mathbf{A} = 5x^2 \left(\sin \frac{\pi x}{2} \right) \mathbf{a}_x$, find $\text{div } \mathbf{A}$ at $x = 1$.

$$\text{div } \mathbf{A} = \frac{\partial}{\partial x} \left(5x^2 \sin \frac{\pi x}{2} \right) = 5x^2 \left(\cos \frac{\pi x}{2} \right) \frac{\pi}{2} + 10x \sin \frac{\pi x}{2} = \frac{5}{2} \pi x^2 \cos \frac{\pi x}{2} + 10x \sin \frac{\pi x}{2}$$

and $\text{div } \mathbf{A}|_{x=1} = 10$.

Problem-6

Given that $\mathbf{D} = (10r^3/4)\mathbf{a}_r$ (C/m²) in the region $0 < r \leq 3$ m in cylindrical coordinates and $\mathbf{D} = (810/4r)\mathbf{a}_r$ (C/m²) elsewhere, find the charge density.

For $0 < r \leq 3$ m,

$$\rho = \frac{1}{r} \frac{\partial}{\partial r} \left(\frac{10r^4}{4} \right) = 10r^2 \text{ (C/m}^3\text{)}$$

and for $r > 3$ m,

$$\rho = \frac{1}{r} \frac{\partial}{\partial r} (810/4) = 0$$

Problem-8

Ex. A charge $Q_1 = -20\mu\text{C}$ is located at $P (-6, 4, 6)$ and a charge $Q_2 = 50\mu\text{C}$ is located at $R (5, 8, -2)$ in a free space. Find the force exerted on Q_2 by Q_1 in vector form. The distances given are in metres.

Sol. : From the co-ordinates of P and R , the respective position vectors are -

$$\bar{\mathbf{P}} = -6\mathbf{a}_x + 4\mathbf{a}_y + 6\mathbf{a}_z$$

and $\bar{\mathbf{R}} = 5\mathbf{a}_x + 8\mathbf{a}_y - 2\mathbf{a}_z$

The force on Q_2 is given by,

$$\bar{\mathbf{F}}_2 = \frac{Q_1 Q_2}{4\pi\epsilon_0 R_{12}^2} \bar{\mathbf{a}}_{12}$$

$$\begin{aligned} \bar{\mathbf{R}}_{12} &= \bar{\mathbf{R}}_{PR} = \bar{\mathbf{R}} - \bar{\mathbf{P}} = [5 - (-6)] \mathbf{a}_x + (8 - 4) \mathbf{a}_y + [-2 - (6)] \mathbf{a}_z \\ &= 11\mathbf{a}_x + 4\mathbf{a}_y - 8\mathbf{a}_z \end{aligned}$$

$$\therefore |\mathbf{R}_{12}| = \sqrt{(11)^2 + (4)^2 + (-8)^2} = 14.1774$$

Gauss's Law:

Gauss's law is one of the fundamental laws of electromagnetism and it states that the total electric flux through a closed surface is equal to the total charge enclosed by the surface.

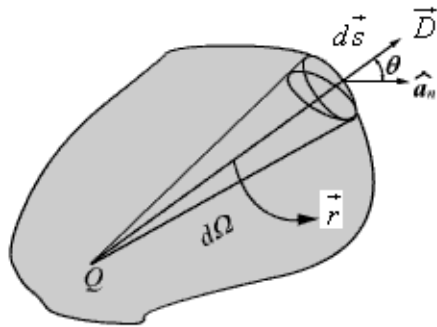

Let us consider a point charge Q located in an isotropic homogeneous medium of dielectric constant. The flux density at a distance r on a surface enclosing the charge is given by

$$\vec{D} = \epsilon \vec{E} = \frac{Q}{4\pi r^2} \hat{a}_r$$

If we consider an elementary area ds , the amount of flux passing through the elementary area is given by

$$d\psi = \vec{D} \cdot d\vec{s} = \frac{Q}{4\pi r^2} ds \cos \theta$$

But $\frac{ds \cos \theta}{r^2} = d\Omega$, is the elementary solid angle subtended by the area $d\vec{s}$ at the location of Q .

Therefore, we can write $d\psi = \frac{Q}{4\pi} d\Omega$

$$\psi = \oint_S d\psi = \frac{Q}{4\pi} \oint_S d\Omega = Q$$

For a closed surface enclosing the charge, we can write

which can be seen to be same as what we have stated in the definition of Gauss's Law.

Hence we have,

$$Q_{\text{enc}} = \oint_S \mathbf{D} \cdot d\mathbf{s} = \int_V \rho_V dv$$

Applying Divergence theorem we have,

$$\oint_S \mathbf{D} \cdot d\mathbf{s} = \int_V \nabla \cdot \mathbf{D} dv$$

Comparing the above two equations, we have

$$\int_V \nabla \cdot \mathbf{D} dv = \int_V \rho_V dv$$

This equation is called the 1st Maxwell's equation of electrostatics.

Application of Gauss's Law:

Gauss's law is particularly useful in computing \vec{E} or \vec{D} where the charge distribution has some symmetry. We shall illustrate the application of Gauss's Law with some examples.

1. \vec{E} due to an infinite line charge

As the first example of illustration of use of Gauss's law, let consider the problem of determination of the electric field produced by an infinite line charge of density $\lambda C/m$. Let us consider a line charge positioned along the z -axis as shown in Fig. 4(a) (next slide). Since the line charge is assumed to be infinitely long, the electric field will be of the form as shown in Fig. 4(b) (next slide).

If we consider a close cylindrical surface as shown in Fig. 2.4(a), using Gauss's theorem we can write,

$$\rho_L = Q = \oint_S \epsilon_0 \vec{E} \cdot d\vec{s} = \int_{S_1} \epsilon_0 \vec{E} \cdot d\vec{s} + \int_{S_2} \epsilon_0 \vec{E} \cdot d\vec{s} + \int_{S_3} \epsilon_0 \vec{E} \cdot d\vec{s}$$

Considering the fact that the unit normal vector to areas S_1 and S_3 are perpendicular to the electric field, the surface integrals for the top and bottom surfaces evaluates to zero. Hence we

can write, $\rho_L = \epsilon_0 E \cdot 2\pi r l$

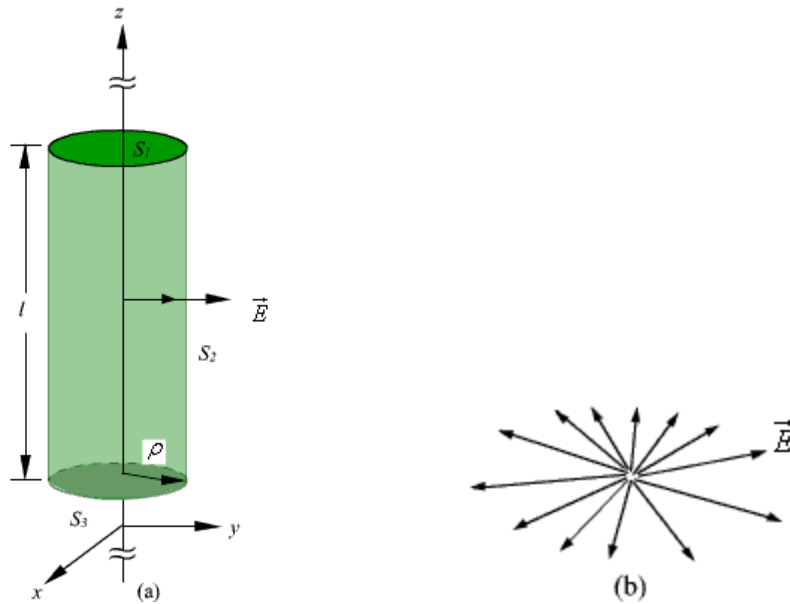

Fig 4: Infinite Line Charge

$$\vec{E} = \frac{\rho_L}{2\pi\epsilon_0\rho} \hat{a}_\rho$$

2. Infinite Sheet of Charge

As a second example of application of Gauss's theorem, we consider an infinite charged sheet covering the x - z plane as shown in figure 5. Assuming a surface charge density of ρ_s for the infinite surface charge, if we consider a cylindrical volume having sides Δs placed symmetrically as shown in figure 5, we can write:

$$\oint_S \vec{D} \cdot d\vec{s} = 2D\Delta s = \rho_s \Delta s$$

$$\therefore \vec{E} = \frac{\rho_s}{2\epsilon_0} \hat{a}_y$$

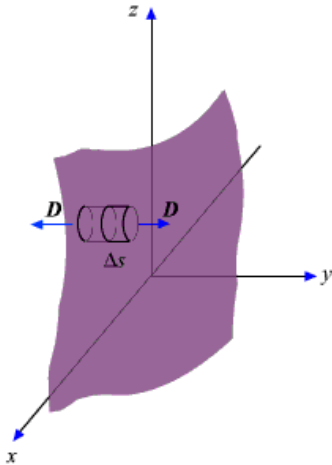

Fig 5: Infinite Sheet of Charge

It may be noted that the electric field strength is independent of distance. This is true for the infinite plane of charge; electric lines of force on either side of the charge will be perpendicular to the sheet and extend to infinity as parallel lines. As number of lines of force per unit area gives the strength of the field, the field becomes independent of distance. For a finite charge sheet, the field will be a function of distance.

3. Uniformly Charged Sphere

Let us consider a sphere of radius r_0 having a uniform volume charge density of ρ_v C/m³. To determine \vec{D} everywhere, inside and outside the sphere, we construct Gaussian surfaces of radius $r < r_0$ and $r > r_0$ as shown in Fig. 6 (a) and Fig. 6(b).

For the region $r \leq r_0$; the total enclosed charge will be

$$Q_{en} = \rho_v \frac{4}{3} \pi r^3$$

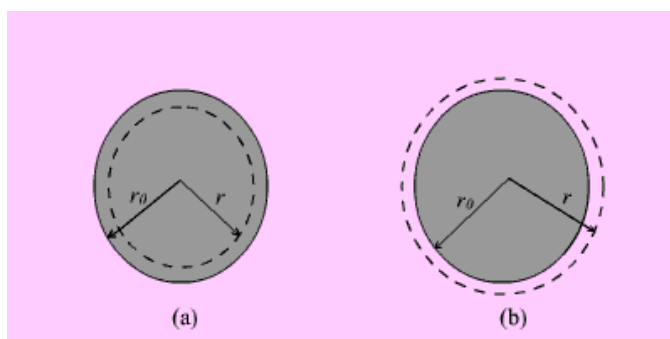

Fig 6: Uniformly Charged Sphere

By applying Gauss's theorem,

$$\oint \vec{D} \cdot d\vec{s} = \int_{\phi=0}^{2\pi} \int_{\theta=0}^{\pi} D_r r^2 \sin \theta d\theta d\phi = 4\pi r^2 D_r = Q_{en}$$

Therefore

$$\vec{D} = \frac{r}{3} \rho_v \hat{a}_r \quad 0 \leq r \leq r_0$$

For the region $r \geq r_0$; the total enclosed charge will be

$$Q_{en} = \rho_v \frac{4}{3} \pi r_0^3$$

By applying Gauss's theorem,

$$\vec{D} = \frac{r_0^3}{3r^2} \rho_v \hat{a}_r \quad r \geq r_0$$

Electric Potential / Electrostatic Potential (V):

If a charge is placed in the vicinity of another charge (or in the field of another charge), it experiences a force. If a field being acted on by a force is moved from one point to another, then work is either said to be done on the system or by the system.

Say a point charge Q is moved from point A to point B in an electric field E , then the work done in moving the point charge is given as:

$$W_{A \rightarrow B} = - \int_{AB} (\mathbf{F} \cdot d\mathbf{l}) = - Q \int_{AB} (\mathbf{E} \cdot d\mathbf{l})$$

where the – ve sign indicates that the work is done on the system by an external agent.

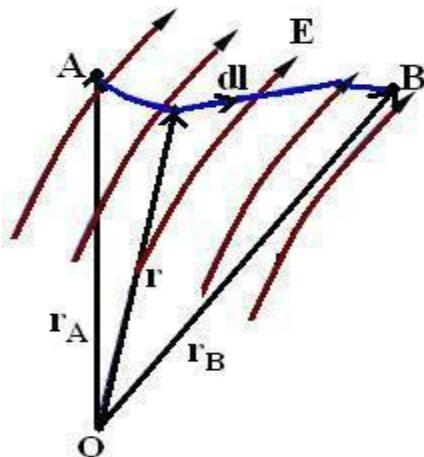

The work done per unit charge in moving a test charge from point A to point B is the electrostatic potential difference between the two points (V_{AB}).

$$V_{AB} = W_{A \rightarrow B} / Q$$

$$- \int_{AB} (\mathbf{E} \cdot d\mathbf{l})$$

$$- \int_{\text{Initial}}^{\text{Final}} (\mathbf{E} \cdot d\mathbf{l})$$

If the potential difference is positive, there is a gain in potential energy in the movement, external agent performs the work against the field. If the sign of the potential difference is negative, work is done by the field.

The electrostatic field is conservative i.e. the value of the line integral depends only on end points and is independent of the path taken.

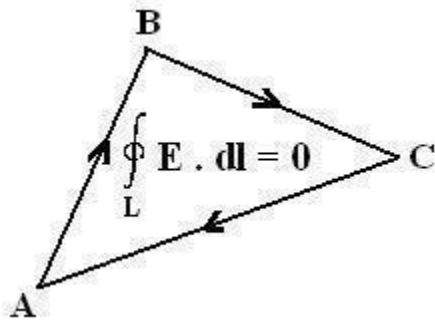

- Since the electrostatic field is conservative, the electric potential can also be written as:

$$V_{AB} = - \int_A^B \bar{\mathbf{E}} \cdot d\bar{\mathbf{l}}$$

$$V_{AB} = - \int_A^{p_0} \bar{\mathbf{E}} \cdot d\bar{\mathbf{l}} - \int_{p_0}^B \bar{\mathbf{E}} \cdot d\bar{\mathbf{l}}$$

$$V_{AB} = - \int_{p_0}^B \bar{\mathbf{E}} \cdot d\bar{\mathbf{l}} + \int_{p_0}^A \bar{\mathbf{E}} \cdot d\bar{\mathbf{l}}$$

$$V_{AB} = V_B - V_A$$

Thus, the potential difference between two points in an electrostatic field is a scalar field that is defined at every point in space and is independent of the path taken.

- The work done in moving a point charge from point A to point B can be written as:

$$W_{A \rightarrow B} = -Q [V_B - V_A] = -Q \int_A^B \vec{E} \cdot d\vec{l}$$

- Consider a point charge Q at origin O.

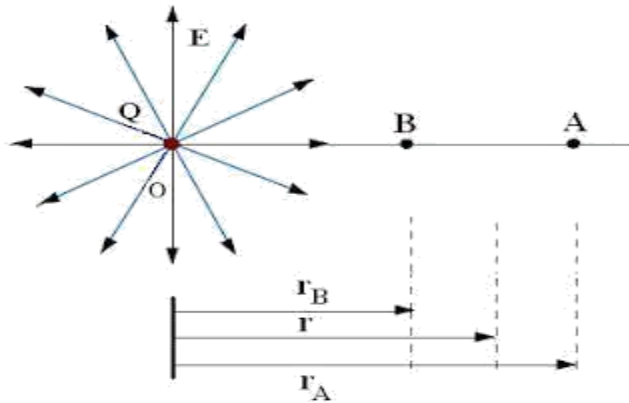

Now if a unit test charge is moved from point A to Point B, then the potential difference between them is given as:

$$\begin{aligned} V_{AB} &= - \int_A^B \vec{E} \cdot d\vec{l} = - \int_{r_A}^{r_B} \vec{E} \cdot d\vec{l} = - \int_{r_A}^{r_B} \frac{Q}{4\pi\epsilon r^2} \hat{a}_r \cdot d\vec{r} \hat{a}_r \\ &= \frac{Q}{4\pi\epsilon} \left(\frac{1}{r_B} - \frac{1}{r_A} \right) = V_B - V_A \end{aligned}$$

- Electrostatic potential or Scalar Electric potential (V) at any point P is given by:

$$V = - \int_{P_0}^P \vec{E} \cdot d\vec{l}$$

The reference point \$P_0\$ is where the potential is zero (analogous to ground in a circuit). The reference is often taken to be at infinity so that the potential of a point in space is defined as

$$V = - \int_{\infty}^P \vec{E} \cdot d\vec{l}$$

Basically, potential is considered to be zero at infinity. Thus potential at any point ($r_B = r$) due to a point charge Q can be written as the amount of work done in bringing a unit positive charge from infinity to that point (i.e. $r_A \rightarrow \infty$)

Electric potential (V) at point r due to a point charge Q located at a point with position vector r_1 is given as:

$$V = \frac{Q}{4\pi\epsilon|\mathbf{r} - \mathbf{r}_1|}$$

Similarly for N point charges $Q_1, Q_2 \dots Q_n$ located at points with position vectors $r_1, r_2, r_3 \dots r_n$, the electric potential (V) at point r is given as:

$$V = \frac{1}{4\pi\epsilon} \sum_{k=1}^N \frac{Q_k}{|\mathbf{r} - \mathbf{r}_k|}$$

The charge element dQ and the total charge due to different charge distribution is given as:

$$dQ = \rho_L dl \rightarrow Q = \int_L (\rho_L dl) \rightarrow (\text{Line Charge}) \quad V = \frac{Q}{4\pi\epsilon r}$$

$$dQ = \rho_S ds \rightarrow Q = \int_S (\rho_S ds) \rightarrow (\text{Surface Charge})$$

$$dQ = \rho_V dv \rightarrow Q = \int_V (\rho_V dv) \rightarrow (\text{Volume Charge})$$

$$V = \int_L \frac{\rho_L dl}{4\pi\epsilon|\mathbf{r} - \mathbf{r}_1|} \quad (\text{Line Charge})$$

$$V = \int_S \frac{\rho_S ds}{4\pi\epsilon|\mathbf{r} - \mathbf{r}_1|} \quad (\text{Surface Charge})$$

$$V = \int_V \frac{\rho_V dv}{4\pi\epsilon|\mathbf{r} - \mathbf{r}_1|} \quad (\text{Volume Charge})$$

Second Maxwell's Equation of Electrostatics:

The work done per unit charge in moving a test charge from point A to point B is the electrostatic potential difference between the two points (V_{AB}).

$$V_{AB} = V_B - V_A$$

Similarly,

$$V_{BA} = V_A - V_B$$

Hence it's clear that potential difference is independent of the path taken. Therefore

$$V_{AB} = -V_{BA}$$

$$V_{AB} + V_{BA} = 0$$

$$\int_{AB} (\mathbf{E} \cdot d\mathbf{l}) + [- \int_{BA} (\mathbf{E} \cdot d\mathbf{l})] = 0$$

$$\oint_L \mathbf{E} \cdot d\mathbf{l} = 0$$

The above equation is called the second Maxwell's Equation of Electrostatics in integral form.. The above equation shows that the line integral of Electric field intensity (E) along a closed path is equal to zero.

In simple words—No work is done in moving a charge along a closed path in an electrostatic field.

Applying Stokes' Theorem to the above Equation, we have:

$$\oint_L \mathbf{E} \cdot d\mathbf{l} = \int_S (\nabla \times \mathbf{E}) \cdot d\mathbf{s} = 0$$

$$\longrightarrow \nabla \times \mathbf{E} = 0$$

If the Curl of any vector field is equal to zero, then such a vector field is called an Irrotational or Conservative Field. Hence an electrostatic field is also called a conservative field.

The above equation is called the second Maxwell 's Equation of Electrostatics in differential form.

Relationship Between Electric Field Intensity (E) and Electric Potential (V):

Since Electric potential is a scalar quantity, hence dV (as a function of x , y and z variables) can be written as:

$$dV = \frac{\partial V}{\partial x} dx + \frac{\partial V}{\partial y} dy + \frac{\partial V}{\partial z} dz$$

$$\left(\frac{\partial V}{\partial x} a_x + \frac{\partial V}{\partial y} a_y + \frac{\partial V}{\partial z} a_z \right) \cdot \left(dx a_x + dy a_y + dz a_z \right) = - \mathbf{E} \cdot d\mathbf{l}$$

$$\nabla V \cdot d\mathbf{l} = - \mathbf{E} \cdot d\mathbf{l} \quad \text{--->} \quad \boxed{\mathbf{E} = -\nabla V}$$

Hence the Electric field intensity (E) is the negative gradient of Electric potential (V).

The negative sign shows that E is directed from higher to lower values of V i.e. E is opposite to the direction in which V increases.

Properties of Materials and Steady Electric Current:

Electric field can not only exist in free space and vacuum but also in any material medium. When an electric field is applied to the material, the material will modify the electric field either by strengthening it or weakening it, depending on what kind of material it is.

Materials are classified into 3 groups based on conductivity / electrical property:

- Conductors (Metals like Copper, Aluminum, etc.) have high conductivity ($\sigma \gg 1$).
- Insulators / Dielectric (Vacuum, Glass, Rubber, etc.) have low conductivity ($\sigma \ll 1$).
- Semiconductors (Silicon, Germanium, etc.) have intermediate conductivity.

Conductivity (σ) is a measure of the ability of the material to conduct electricity. It is the reciprocal of resistivity (ρ). Units of conductivity are Siemens/meter and mho.

The basic difference between a conductor and an insulator lies in the amount of free electrons available for conduction of current. Conductors have a large amount of free electrons whereas insulators have only a few number of electrons for conduction of current. Most of the conductors obey ohm's law. Such conductors are also called ohmic conductors.

Due to the movement of free charges, several types of electric current can be caused.

The different types of electric current are:

- Conduction Current.
- Convection Current.
- Displacement Current.

Electric current:

Electric current (I) defines the rate at which the net charge passes through a wire of cross-sectional surface area S.

Mathematically,

If a net charge ΔQ moves across surface S in some small amount of time Δt , electric current(I) is defined as:

$$I = \lim_{\Delta t \rightarrow 0} \frac{\Delta Q}{\Delta t} = \frac{dQ}{dt}$$

How fast or how speed the charges will move depends on the nature of the material medium.

Current density:

Current density (J) is defined as current ΔI flowing through surface ΔS .

Imagine surface area ΔS inside a conductor at right angles to the flow of current. As the area approaches zero, the current density at a point is defined as:

$$J = \lim_{\Delta S \rightarrow 0} \frac{\Delta I}{\Delta S}$$

The above equation is applicable only when current density (J) is normal to the surface.

In case if current density(J) is not perpendicular to the surface, consider a small area ds of the conductor at an angle θ to the flow of current as shown:

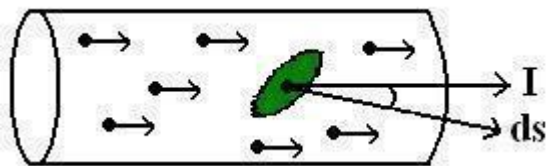

In this case current flowing through the area is given as:

$$dI = J \, dS \, \cos\theta = J \cdot d\vec{S} \quad \text{and} \quad I = \int_S \vec{J} \cdot d\vec{S}$$

Where angle θ is the angle between the normal to the area and direction of the current.
From the above equation it's clear that electric current is a scalar quantity.

CONTINUITY EQUATION:

The continuity equation is derived from two of Maxwell's equations. It states that the divergence of the current density is equal to the negative rate of change of the charge density,

$$\nabla \cdot \mathbf{J} = -\frac{\partial \rho}{\partial t}.$$

Derivation

One of Maxwell's equations, Ampère's law, states that

$$\nabla \times \mathbf{H} = \mathbf{J} + \frac{\partial \mathbf{D}}{\partial t}.$$

Taking the divergence of both sides results in

$$\nabla \cdot \nabla \times \mathbf{H} = \nabla \cdot \mathbf{J} + \frac{\partial \nabla \cdot \mathbf{D}}{\partial t},$$

but the divergence of a curl is zero, so that

$$\nabla \cdot \mathbf{J} + \frac{\partial \nabla \cdot \mathbf{D}}{\partial t} = 0. \quad (1)$$

Another one of Maxwell's equations, Gauss's law, states that

$$\nabla \cdot \mathbf{D} = \rho.$$

Substitute this into equation (1) to obtain

$$\nabla \cdot \mathbf{J} + \frac{\partial \rho}{\partial t} = 0,$$

which is the continuity equation.

Relaxation Time

Relaxation time can be defined as the time taken by electron to attain an average velocity which is $1/e$ times its value.

The different physics interfaces involving only the scalar electric potential can be interpreted in terms of the charge relaxation process. The fundamental equations involved are *Ohm's law* for the conduction current density

$$\mathbf{J}_c = \sigma \mathbf{E}$$

the *equation of continuity*

$$\frac{\partial \rho}{\partial t} + \nabla \cdot \mathbf{J}_c = 0$$

and *Gauss' law*

$$\nabla \cdot (\epsilon \mathbf{E}) = \rho$$

By combining these, one can deduce the following differential equation for the space charge density in a homogeneous medium

$$\frac{\partial \rho}{\partial t} + \frac{\sigma}{\epsilon} \rho = 0$$

This equation has the solution

$$\rho(t) = \rho_0 e^{-t/\tau}$$

where

$$\tau = \frac{\epsilon}{\sigma}$$

is called the charge relaxation time.

LAPLACE'S AND POISSON'S EQUATIONS:

A useful approach to the calculation of electric potentials is to relate that potential to the charge density which gives rise to it. The electric field is related to the charge density by the divergence relationship

$$\nabla \cdot \mathbf{E} = \frac{\rho}{\epsilon_0}$$

\mathbf{E} = electric field
 ρ = charge density
 ϵ_0 = permittivity

and the electric field is related to the electric potential by a gradient relationship

$$\mathbf{E} = -\nabla V$$

Therefore the potential is related to the charge density by Poisson's equation

$$\nabla \cdot \nabla V = \nabla^2 V = \frac{-\rho}{\epsilon_0}$$

In a charge-free region of space, this becomes Laplace's equation

$$\nabla^2 V = 0$$

This mathematical operation, the divergence of the gradient of a function, is called the Laplacian. Expressing the Laplacian in different coordinate systems to take advantage of the symmetry of a charge distribution helps in the solution for the electric potential V . For example, if the charge distribution has spherical symmetry, you use the Laplacian in spherical polar coordinates.

Since the potential is a scalar function, this approach has advantages over trying to calculate the electric field directly. Once the potential has been calculated, the electric field can be computed by taking the gradient of the potential.

Solved problems:

Problem1:

Three point charges, $Q_1 = 30 \text{ nC}$, $Q_2 = 150 \text{ nC}$, and $Q_3 = -70 \text{ nC}$, are enclosed by surface S . What net flux crosses S ?

Since **electric flux** was defined as originating **on** positive charge and terminating **on** negative charge, part of the flux from the positive charges terminates **on** the negative charge.

$$\Psi_{\text{net}} = Q_{\text{net}} = 30 + 150 - 70 = 110 \text{ nC}$$

Problem-2

What **electric** field intensity and current density correspond to a drift velocity of $6.0 \times 10^{-4} \text{ m/s}$ in a silver conductor?

For silver $\sigma = 61.7 \text{ MS/m}$ and $\mu = 5.6 \times 10^{-3} \text{ m}^2/\text{V} \cdot \text{s}$.

$$E = \frac{U}{\mu} = \frac{6.0 \times 10^{-4}}{5.6 \times 10^{-3}} = 1.07 \times 10^{-1} \text{ V/m}$$

$$J = \sigma E = 6.61 \times 10^6 \text{ A/m}^2$$

Problem-3

Find the current in the circular wire shown in Fig. 6.6 if the current density is $\mathbf{J} = 15(1 - e^{-1000r})\mathbf{a}_z \text{ (A/m}^2\text{)}$. The radius of the wire is 2 mm.

A cross section of the wire is chosen for S . Then

$$\begin{aligned} dI &= \mathbf{J} \cdot d\mathbf{S} \\ &= 15(1 - e^{-1000r})\mathbf{a}_z \cdot r dr d\phi \mathbf{a}_z \end{aligned}$$

and

$$\begin{aligned} I &= \int_0^{2\pi} \int_0^{0.002} 15(1 - e^{-1000r})r dr d\phi \\ &= 1.33 \times 10^{-4} \text{ A} = 0.133 \text{ mA} \end{aligned}$$

Any surface S which has a perimeter that meets the outer surface of the conductor all the way around will have the same total current, $I = 0.133 \text{ mA}$, crossing it.

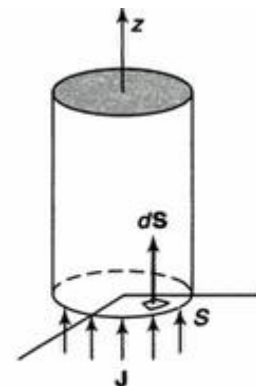

Fig. 6.6

Problem-4

Determine the relaxation time for silver, given that $\sigma = 6.17 \times 10^7 \text{ S/m}$. If charge of density ρ_0 is placed within a silver block, find ρ after one, and also after five, time constants.

Since $\epsilon = \epsilon_0$,

$$\tau = \frac{\epsilon}{\sigma} = \frac{10^{-9} 36\pi}{6.17 \times 10^7} = 1.43 \times 10^{-19} \text{ s}$$

Therefore

$$\text{at } t = \tau: \quad \rho = \rho_0 e^{-1} = 0.368\rho_0$$

$$\text{at } t = 5\tau: \quad \rho = \rho_0 e^{-5} = 6.74 \times 10^{-3}\rho_0$$

UNIT-II

MAGNETOSTATICS

Contents:

Magnetostatics:

- Biot - Savart's Law
- Ampere's Circuital Law and Applications
- Magnetic Flux Density
- Maxwell's Equations for Magnetostatic Fields
- Magnetic Scalar and Vector Potentials
- Forces due to Magnetic Fields
- Ampere's Force Law

Maxwell's Equations (Time Varying Fields):

- Faraday's Law
- Inconsistency of Ampere's Law and
- Displacement Current Density
- Maxwell's Equations in Different Final Forms
- Conditions at a Boundary Surface: Dielectric – Dielectric
- Illustrative Problems.

Introduction:

The source of steady magnetic field may be a permanent magnet, a direct current or an electric field changing with time. In this chapter we shall mainly consider the magnetic field produced by a direct current. The magnetic field produced due to time varying electric field will be discussed later.

There are two major laws governing the magneto static fields are:

- Biot-Savart Law
- Ampere's Law

Usually, the magnetic field intensity is represented by the vector \vec{H} . It is customary to represent the direction of the magnetic field intensity (or current) by a small circle with a dot or cross sign depending on whether the field (or current) is out of or into the page as shown in Fig. 2.1.

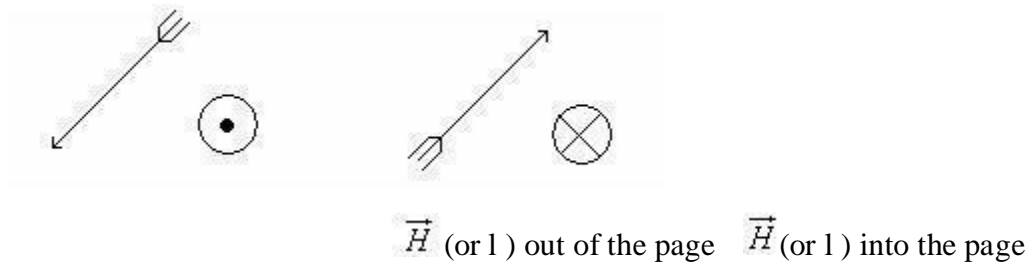
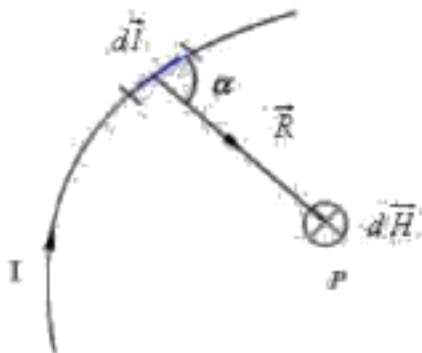

Fig. Representation of magnetic field (or current)

Biot- Savart's Law:

This law relates the magnetic field intensity dH produced at a point due to a differential current element $Id\vec{l}$ as shown in Fig.



The magnetic field intensity $d\vec{H}$ at P can be written as,

$$d\vec{H} = \frac{Id\vec{l} \times \hat{a}_R}{4\pi R^2} = \frac{Id\vec{l} \times \vec{R}}{4\pi R^3}$$

$$dH = \frac{Idl \sin \alpha}{4\pi R^2}$$

where $R = |\vec{R}|$ is the distance of the current element from the point P.

The value of the constant of proportionality 'K' depends upon a property called permeability of the medium around the conductor. Permeability is represented by symbol 'm' and the constant 'K' is expressed in terms of 'm' as

Thus

$$dB = \frac{\mu}{4\pi} \frac{I dl \sin \theta}{r^2}$$

Magnetic field 'B' is a vector and unless we give the direction of 'dB', its description is not complete. Its direction is found to be perpendicular to the plane of 'r' and 'dl'.

If we assign the direction of the current 'I' to the length element 'dl', the vector product $dl \times r$ has magnitude $r dl \sin \theta$ and direction perpendicular to 'r' and 'dl'.

Hence, Biot-Savart law can be stated in vector form to give both the magnitude as well as direction of magnetic field due to a current element as

$$\vec{dB} = \frac{\mu}{4\pi} \frac{I (\vec{dl} \times \vec{r})}{r^3}$$

Similar to different charge distributions, we can have different current distribution such as line current, surface current and volume current. These different types of current densities are shown in Fig. 2.3.

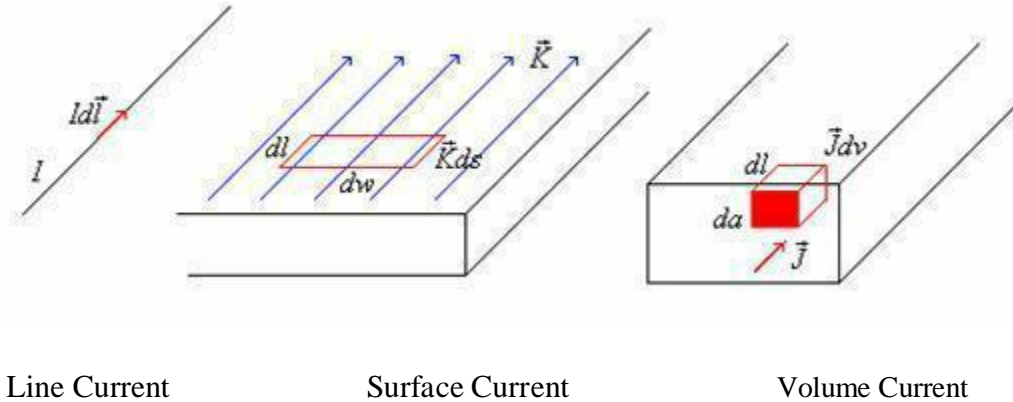

Fig. 2.3: Different types of current distributions

By denoting the surface current density as K (in amp/m) and volume current density as J (in amp/m²) we can write:

$$Id\vec{l} = \vec{K}ds = \vec{J}dv$$

(It may be noted that $I = Kdw = Jda$)

Employing Biot -Savart Law, we can now express the magnetic field intensity H. In terms of these current distributions as

$$\vec{H} = \int \frac{Id\vec{l} \times \vec{R}}{4\pi R^3} \dots\dots\dots \text{for line current} \dots\dots\dots$$

$$\vec{H} = \int \frac{Kd\vec{s} \times \vec{R}}{4\pi R^3} \dots\dots\dots \text{for surface current} \dots\dots\dots$$

$$\vec{H} = \int \frac{\vec{J}dv \times \vec{R}}{4\pi R^3} \dots\dots\dots \text{for volume current} \dots\dots\dots$$

\vec{H} Due to infinitely long straight conductor:

We consider a finite length of a conductor carrying a current \vec{I} placed along z-axis as shown in the Fig 2.4. We determine the magnetic field at point P due to this current carrying conductor.

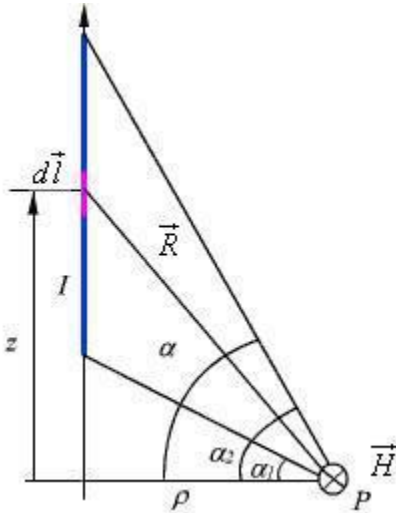

Fig. 2.4: Field at a point P due to a finite length current carrying conductor

With reference to Fig. 2.4, we find that

$$d\vec{l} = dz \hat{a}_z \text{ and } \vec{R} = \rho \hat{a}_\rho - z \hat{a}_z$$

Applying Biot - Savart's law for the current element $\vec{I} d\vec{l}$ We can write,

$$d\vec{H} = \frac{I d\vec{l} \times \vec{R}}{4\pi r^3} = \frac{\rho dz \hat{a}_\phi}{4\pi[\rho^2 + z^2]^{3/2}}$$

$$\frac{z}{\rho} = \tan \alpha$$

Substituting ρ we can write,

$$\vec{H} = \int_{\alpha_1}^{\alpha_2} \frac{I \rho^2 \sec^2 \alpha d\alpha}{4\pi \rho^3 \sec^3 \alpha} \hat{a}_\phi = \frac{I}{4\pi \rho} (\sin \alpha_2 - \sin \alpha_1) \hat{a}_\phi$$

We find that, for an infinitely long conductor carrying a current I, $\alpha_2 = 90^\circ$ and $\alpha_1 = -90^\circ$
Therefore

$$\vec{H} = \frac{I}{2\pi \rho} \hat{a}_\phi$$

Ampere's Circuital Law:

Ampere's circuital law states that the line integral of the magnetic field \vec{H} (circulation of H) around a closed path is the net current enclosed by this path. Mathematically,

$$\oint \vec{H} \cdot d\vec{l} = I_{enc}$$

The total current I_{enc} can be written as,

$$I_{enc} = \int_S \vec{J} \cdot d\vec{s}$$

By applying Stoke's theorem, we can write

$$\begin{aligned} \oint \vec{H} \cdot d\vec{l} &= \int_S \nabla \times \vec{H} \cdot d\vec{s} \\ \therefore \int_S \nabla \times \vec{H} \cdot d\vec{s} &= \int_S \vec{J} \cdot d\vec{s} \\ \therefore \nabla \times \vec{H} &= \vec{J} \end{aligned}$$

Which is the Ampere's circuital law in the point form and Maxwell's equation for magneto static fields.

Applications of Ampere's circuital law:

1. It is used to find \vec{H} and \vec{B} due to any type of current distribution.
2. If \vec{H} or \vec{B} is known then it is also used to find current enclosed by any closed path.

We illustrate the application of Ampere's Law with some examples.

\vec{H} Due to infinitely long straight conductor :(using Ampere's circuital law)

We compute magnetic field due to an infinitely long thin current carrying conductor as shown in Fig. 2.5. Using Ampere's Law, we consider the close path to be a circle of radius ρ as shown in the Fig. 4.5.

If we consider a small current element $Id\vec{l}(= Idz\hat{a}_z)$, $d\vec{H}$ is perpendicular to the plane containing both $d\vec{l}$ and $\vec{R}(= \rho\hat{a}_\rho)$. Therefore only component of \vec{H} that will be present is H_ϕ , i.e., $\vec{H} = H_\phi\hat{a}_\phi$.

By applying Ampere's law we can write,

$$\vec{H} = \frac{I}{2\pi\rho} \hat{a}_\phi \int_0^{2\pi} H_\phi \rho d\phi = H_\phi \rho 2\pi = I$$

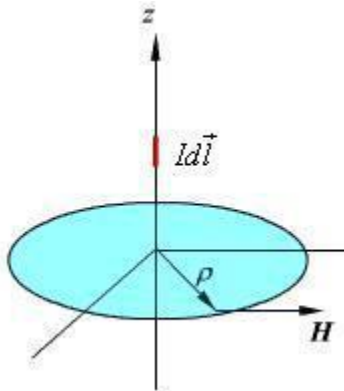

Fig. Magnetic field due to an infinite thin current carrying conductor

\vec{H} Due to infinitely long coaxial conductor :(using Ampere's circuital law)

We consider the cross section of an infinitely long coaxial conductor, the inner conductor carrying a current I and outer conductor carrying current $-I$ as shown in figure 2.6. We compute the magnetic field as a function of ρ as follows:

In the region $0 \leq \rho \leq R_1$

$$I_{enc} = I \frac{\rho^2}{R_1^2}$$

$$H_\phi = \frac{I_{enc}}{2\pi\rho} = \frac{I\rho}{2\pi a^2}$$

In the region $R_1 \leq \rho \leq R_2$

$$I_{enc} = I$$

$$H_\phi = \frac{I}{2\pi\rho}$$

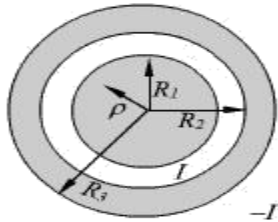

Fig. 2.6: Coaxial conductor carrying equal and opposite currents in the region

$R_2 \leq \rho \leq R_3$

$$H_\phi = \frac{I}{2\pi\rho} \frac{R_3^2 - \rho^2}{R_3^2 - R_2^2}$$

In the region $\rho > R_3$

$$I_{enc} = 0 \quad H_\phi = 0$$

Magnetic Flux Density:

In simple matter, the magnetic flux density \vec{B} related to the magnetic field intensity \vec{H} as $\vec{B} = \mu\vec{H}$ where μ called the permeability. In particular when we consider the free space $\vec{B} = \mu_0\vec{H}$ where $\mu_0 = 4\pi \times 10^{-7}$ H/m is the permeability of the free space. Magnetic flux density is measured in terms of Wb/m².

The magnetic flux density through a surface is given by:

$$\psi = \int_S \vec{B} \cdot d\vec{s} \quad \text{Wb}$$

In the case of electrostatic field, we have seen that if the surface is a closed surface, the net flux passing through the surface is equal to the charge enclosed by the surface. In case of magnetic field isolated magnetic charge (i. e. pole) does not exist. Magnetic poles always occur in pair (as N-S). For example, if we desire to have an isolated magnetic pole by dividing the magnetic bar successively into two, we end up with pieces each having north (N) and south (S) pole as shown in Fig. 6 (a). This process could be continued until the magnets are of atomic dimensions; still we will have N-S pair occurring together. This means that the magnetic poles cannot be isolated.

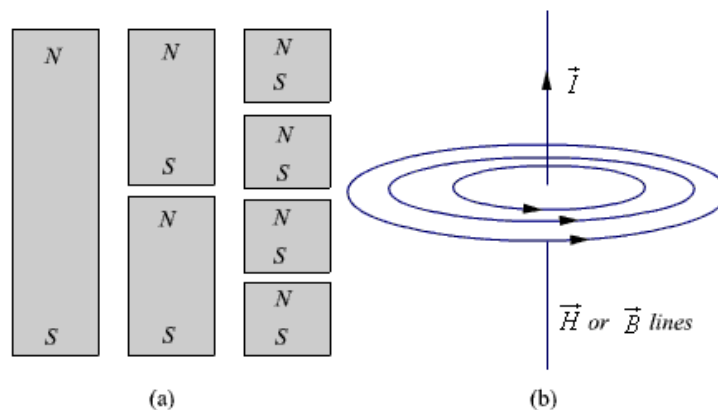

Fig. 6: (a) Subdivision of a magnet (b) Magnetic field/ flux lines of a straight current carrying conductor

Maxwell's 2nd equation for static magnetic fields:

Similarly if we consider the field/flux lines of a current carrying conductor as shown in Fig. 6 (b), we find that these lines are closed lines, that is, if we consider a closed surface, the number of flux lines that would leave the surface would be same as the number of flux lines that would enter the surface.

From our discussions above, it is evident that for magnetic field,

$$\oint_S \vec{B} \cdot d\vec{s} = 0$$

.....in integral form

which is the Gauss's law for the magnetic field.

By applying divergence theorem, we can write:

$$\oint_S \vec{B} \cdot d\vec{s} = \int_V \nabla \cdot \vec{B} dv = 0$$

Hence, $\nabla \cdot \vec{B} = 0$ in point/differential form

which is the Gauss's law for the magnetic field in point form.

Magnetic Scalar and Vector Potentials:

In studying electric field problems, we introduced the concept of electric potential that simplified the computation of electric fields for certain types of problems. In the same manner let us relate the magnetic field intensity to a scalar magnetic potential and write:

$$\vec{H} = -\nabla V_m$$

From Ampere's law , we know that

$$\nabla \times \vec{H} = \vec{J}$$

Therefore, $\nabla \times (-\nabla V_m) = \vec{J}$

But using vector identity, $\nabla \times (\nabla V) = 0$ we find that $\vec{H} = -\nabla V_m$ is valid only where $\vec{J} = 0$.

Thus the scalar magnetic potential is defined only in the region where $\vec{J} = 0$. Moreover, V_m in general is not a single valued function of position. This point can be illustrated as follows. Let us consider the cross section of a coaxial line as shown in fig 7.

In the region $a < \rho < b$, $\vec{J} = 0$ and $\vec{H} = \frac{I}{2\pi\rho} \hat{a}_\phi$

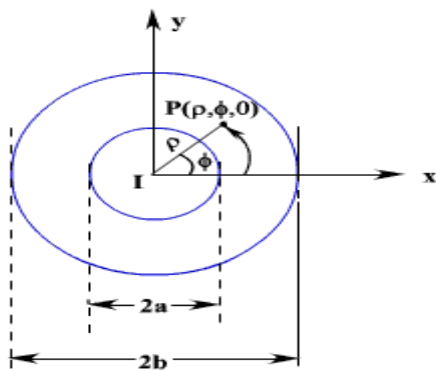

Fig. 7: Cross Section of a Coaxial Line

If V_m is the magnetic potential then,

$$\begin{aligned} -\nabla V_m &= -\frac{1}{\rho} \frac{\partial V_m}{\partial \phi} \\ &= \frac{I}{2\pi\phi} \end{aligned}$$

If we set $V_m = 0$ at $\phi = 0$ then $c=0$ and $V_m = -\frac{I}{2\pi} \phi$

$$\therefore \text{At } \phi = \phi_0 \quad V_m = -\frac{I}{2\pi} \phi_0$$

We observe that as we make a complete lap around the current carrying conductor, we reach ϕ_0 again but V_m this time becomes

$$V_m = -\frac{I}{2\pi} (\phi_0 + 2\pi)$$

We observe that value of V_m keeps changing as we complete additional laps to pass through the same point. We introduced V_m analogous to electrostatic potential V .

But for static electric fields,

$$\nabla \times \vec{E} = 0 \quad \text{and} \quad \oint \vec{E} \cdot d\vec{l} = 0$$

whereas for steady magnetic field $\nabla \times \vec{H} = \vec{J}$ wherever $\vec{J} = 0$ but $\oint \vec{H} \cdot d\vec{l} = I$ even if $\vec{J} = 0$ along the path of integration.

We now introduce the vector magnetic potential which can be used in regions where current density may be zero or nonzero and the same can be easily extended to time varying cases. The use of vector magnetic potential provides elegant ways of solving EM field problems.

Since $\nabla \cdot \vec{B} = 0$ and we have the vector identity that for any vector \vec{A} , $\nabla \cdot (\nabla \times \vec{A}) = 0$, we can write $\vec{B} = \nabla \times \vec{A}$.

Here, the vector field \vec{A} is called the vector magnetic potential. Its SI unit is Wb/m. Thus if can find \vec{A} of a given current distribution, \vec{B} can be found from \vec{A} through a curl operation. We have introduced the vector function \vec{B} and \vec{A} related its curl to \vec{B} . A vector function is defined fully in terms of its curl as well as divergence. The choice of $\nabla \cdot \vec{A}$ is made as follows.

$$\nabla \times \nabla \times \vec{A} = \mu \nabla \times \vec{H} = \mu \vec{J}$$

By using vector identity, $\nabla \times \nabla \times \vec{A} = \nabla(\nabla \cdot \vec{A}) - \nabla^2 \vec{A}$
 $\nabla(\nabla \cdot \vec{A}) - \nabla^2 \vec{A} = \mu \vec{J}$

Great deal of simplification can be achieved if we choose $\nabla \cdot \vec{A} = 0$.

Putting $\nabla \cdot \vec{A} = 0$, we get $\nabla^2 \vec{A} = -\mu \vec{J}$ which is vector poisson equation.

In Cartesian coordinates, the above equation can be written in terms of the components as

$$\nabla^2 A_x = -\mu J_x$$

$$\nabla^2 A_y = -\mu J_y$$

$$\nabla^2 A_z = -\mu J_z$$

The form of all the above equation is same as that of

$$\nabla^2 V = -\frac{\rho}{\epsilon}$$

for which the solution is

$$V = \frac{1}{4\pi\epsilon} \int_V \frac{\rho}{R} dv', \quad R = |\vec{r} - \vec{r}'|$$

$$\nabla \cdot \vec{A} = \mu\epsilon \frac{\partial V}{\partial t}$$

In case of time varying fields we shall see that $\nabla \cdot \vec{A} = \mu\epsilon \frac{\partial V}{\partial t}$, which is known as Lorentz condition, V being the electric potential. Here we are dealing with static magnetic field, so $\nabla \cdot \vec{A} = 0$.

By comparison, we can write the solution for A_x as

$$A_x = \frac{\mu}{4\pi} \int_V \frac{J_x}{R} dv'$$

Computing similar solutions for other two components of the vector potential, the vector potential can be written as

$$\vec{A} = \frac{\mu}{4\pi} \int_V \frac{\vec{J}}{R} dv'$$

This equation enables us to find the vector potential at a given point because of a volume current density \vec{J} .

Similarly for line or surface current density we can write

$$\vec{A} = \frac{\mu}{4\pi} \int_V \frac{I}{R} d\vec{l}'$$

$$\vec{A} = \frac{\mu}{4\pi} \int_S \frac{\vec{K}}{R} ds'$$

The magnetic flux ψ through a given area S is given by

$$\psi = \int_S \vec{B} \cdot d\vec{s}$$

Substituting $\vec{B} = \nabla \times \vec{A}$

$$\psi = \int_S \nabla \times \vec{A} \cdot d\vec{s} = \oint_C \vec{A} \cdot d\vec{l}$$

Vector potential thus have the physical significance that its integral around any closed path is equal to the magnetic flux passing through that path.

Forces due to magnetic fields

There are at least three ways in which force due to magnetic fields can be experienced. The force can be (a) due to a moving charged particle in a (B) field, (b) on a current element in an external (B) field, or (c) between two current elements.

Force on a Charged Particle

The electric force (F_e) on a moving electric charge (Q) in an electric field is given by Coulomb's experimental law and is related to the electric field intensity (E) as

$$F_e = Q E \text{-----(1)}$$

This shows that if Q is positive, F_e and E have the same direction.

A magnetic field can exert force only on a moving charge. From experiments, it is found that the magnetic force (F_m) experienced by a charge (Q) moving with a velocity (u) in a magnetic field (B) is

$$F_m = Q u \times B \text{-----(2)}$$

This clearly shows that (F_m) is perpendicular to both (u) and (B).

From eqs. (1) and (2), a comparison between the electric force F_e and the magnetic force F_m can be made. F_e is independent of the velocity of the charge and can perform work on the charge and change its kinetic energy. Unlike F_e , F_m depends on the charge velocity and is normal to it. F_m cannot perform work because it is at right angles to the direction of motion of the charge ($F_m \cdot dl = 0$); it does not cause an increase in kinetic energy of the charge. The magnitude of F_m is generally small compared to F_e except at high velocities.

For a moving charge Q in the presence of both electric and magnetic fields, the total force on the charge is given by

$$F = F_e + F_m$$

Or

$$F = Q (E + u \times B)$$

This is known as the (Lorentz *force equation*). It relates mechanical force to electrical force. If the mass of the charged particle moving in E and B fields is m , by Newton's second law of motion.

$$F = m \frac{d u}{d t} = Q (E + u \times B)$$

Force on a Current Element

To determine the force on a current element ($I \, d\mathbf{l}$) of a current – carrying conductor due to the magnetic field (\mathbf{B}), we modify eq. (2) using the fact that for convection current

$$\mathbf{J} = \rho_v \mathbf{u}$$

To recall the relationship between current elements:

$$I \, d\mathbf{l} = \mathbf{K} \, d\mathbf{s} = \mathbf{J} \, d\mathbf{v}$$

Combining eqs. (5 – 5) and (5 – 6) yields

$$I \, d\mathbf{l} = \rho_v \mathbf{u} \, d\mathbf{v} = dQ \mathbf{u}$$

Alternatively, $I \, d\mathbf{l} = \frac{dQ}{dt} \, d\mathbf{l} = dQ \frac{d\mathbf{l}}{dt} = \underline{dQ \mathbf{u}}$

Hence,

$$I \, d\mathbf{l} = \underline{dQ \mathbf{u}}$$

This shows that an elemental charge (dQ) moving with velocity \mathbf{u} (thereby producing convection current element $dQ \mathbf{u}$) is equivalent to a conduction current element $I \, d\mathbf{l}$. Thus, the force on current element $I \, d\mathbf{l}$ in a magnetic field \mathbf{B} is found from eq. (2) by merely replacing $Q \mathbf{u}$ by $I \, d\mathbf{l}$; that is,

$$d\mathbf{F} = I \, d\mathbf{l} \times \mathbf{B}$$

If the current I is through a closed path \mathbf{L} or circuit, the force on the circuit is given by

$$\mathbf{F} = \oint_L I \, d\mathbf{l} \times \mathbf{B}$$

Also have surface current elements ($\mathbf{K} \, d\mathbf{S}$) or a volume current element ($\mathbf{J} \, d\mathbf{v}$)

$$\mathbf{F} = \int_S \mathbf{K} \, d\mathbf{S} \times \mathbf{B} \quad , \quad \mathbf{F} = \int_V \mathbf{J} \, d\mathbf{v} \times \mathbf{B}$$

Force between Two Current Elements

The force between two elements $I_1 \, d\mathbf{l}_1$ and $I_2 \, d\mathbf{l}_2$. According to Biot – Savart's law, both current element produce magnetic fields. So may find the forced ($d\mathbf{F}_1$) on element $I_1 \, d\mathbf{l}_1$ due to the field $d\mathbf{B}_2$ produced by element $I_2 \, d\mathbf{l}_2$ as shown in figure (5 – 1). From eq. (5 – 8),

$$d(dF_1) = I_1 dl_1 \times dB_2$$

But from Biot – Savart's law,

$$dB_2 = \frac{\mu_0 I_2 dl_2 \times a_{R21}}{4\pi R_{21}^2}$$

Hence

$$d(dF_1) = \frac{\mu_0 I_1 dl_1 \times (I_2 dl_2 \times a_{R21})}{4\pi R_{21}^2}$$

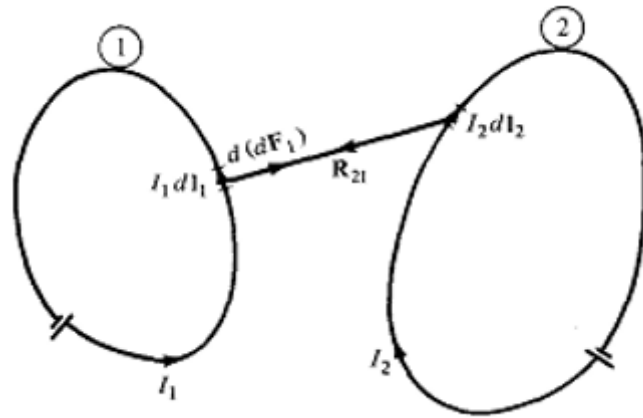

Fig. Force between Two Current Elements

This equation is essentially the law of force between two current element and is analogous to Coulomb's law, which expresses the force between two stationary charges. From eq. (5 – 12) , can to obtain the total force F_1 on current loop (1) due to current loop (2) shown in figure (5 – 1) as

$$F_1 = \frac{\mu_0 I_1 I_2}{4\pi} \oint_{L_1} \oint_{L_2} \frac{dl_1 \times (dl_2 \times a_{R_{21}})}{R_{21}^2}$$

The force F_2 on loop (2) due to the magnetic field B_1 from loop (1) is obtained from above eq. by interchanging subscripts 1 and 2 . It can be shown that $F_2 = - F_1$;

Maxwell's Equations (Time Varying Fields)

Faraday's Law:

Michael Faraday, in 1831 discovered experimentally that a current was induced in a conducting loop when the magnetic flux linking the loop changed. In terms of fields, we can say that a time varying magnetic field produces an electromotive force (emf) which causes a current in a closed circuit. The quantitative relation between the induced emf (the voltage that arises from conductors moving in a magnetic field or from changing magnetic fields) and the rate of change of flux linkage developed based on experimental observation is known as Faraday's law.

Any change in the magnetic environment of a coil of wire will cause a voltage (emf) to be "induced" in the coil. No matter how the change is produced, the voltage will be generated. The change could be produced by changing the magnetic field strength, moving a magnet toward or away from the coil, moving the coil into or out of the magnetic field, rotating the coil relative to the magnet, etc.

Faraday's law is a fundamental relationship which comes from Maxwell's equations. It serves as a succinct summary of the ways a voltage (or emf) may be generated by a changing magnetic environment. The induced emf in a coil is equal to the negative of the rate of change of magnetic flux times the number of turns in the coil. It involves the interaction of charge with magnetic field.

When two current carrying conductors are placed next to each other, we notice that each induces a force on the other. Each conductor produces a magnetic field around itself (Biot– Savart law) and the second experiences a force that is given by the Lorentz force.

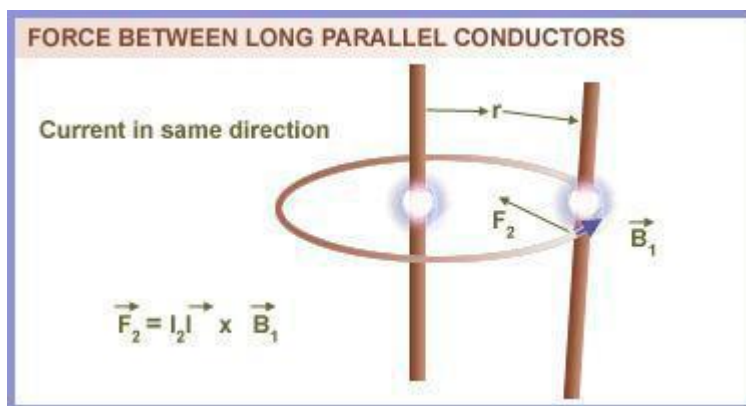

Mathematically, the induced emf can be written as

$$\text{Emf} = - \frac{d\phi}{dt} \text{ Volts}$$

where ϕ is the flux linkage over the closed path. A non zero $\frac{d\phi}{dt}$ may result due to any of the following:

- (a) time changing flux linkage a stationary closed path.
- (b) relative motion between a steady flux a closed path.
- (c) a combination of the above two cases.

The negative sign in equation (7) was introduced by Lenz in order to comply with the polarity of the induced emf. The negative sign implies that the induced emf will cause a current flow in the closed loop in such a direction so as to oppose the change in the linking magnetic flux which produces it. (It may be noted that as far as the induced emf is concerned, the closed path forming a loop does not necessarily have to be conductive).

If the closed path is in the form of N tightly wound turns of a coil, the change in the magnetic flux linking the coil induces an emf in each turn of the coil and total emf is the sum of the induced emfs of the individual turns, i.e.,

$$\text{Emf} = -N \frac{d\phi}{dt} \quad \text{Volts}$$

By defining the total flux linkage as

$$\lambda = N\phi$$

The emf can be written as

$$\text{Emf} = - \frac{d\lambda}{dt}$$

Continuing with equation (3), over a closed contour 'C' we can write

$$\text{Emf} = \oint_C \vec{E} \cdot d\vec{l}$$

where \vec{E} is the induced electric field on the conductor to sustain the current.

Further, total flux enclosed by the contour 'C' is given by

$$\phi = \int_S \vec{B} \cdot d\vec{s}$$

Where S is the surface for which 'C' is the contour.

From (11) and using (12) in (3) we can write

$$\oint_C \vec{E} \cdot d\vec{l} = - \frac{\partial}{\partial t} \oint_S \vec{B} \cdot d\vec{s}$$

By applying stokes theorem

$$\int_S \nabla \times \vec{E} \cdot d\vec{s} = - \int_S \frac{\partial \vec{B}}{\partial t} \cdot d\vec{s}$$

Therefore, we can write

$$\nabla \times \vec{E} = -\frac{\partial \vec{B}}{\partial t}$$

which is the Faraday's law in the point form

We have said that non zero $\frac{d\phi}{dt}$ can be produced in a several ways. One particular case is when a time varying flux linking a stationary closed path induces an emf. The emf induced in a stationary closed path by a time varying magnetic field is called a transformer emf .

Displacement Current Density:

The equation

$\Delta \times H = J$ For static EM fields is modified to Modified to

$$\Delta \times H = J + J_d \quad (3.19)$$

To make the Ampere's law compatible for varying fields.

Now, applying divergence, we get

$$\begin{aligned} \Delta(\Delta \times H) &= 0 = \Delta J + \Delta J_d \\ \Delta J_d &= -\Delta J = \frac{de_v}{dt} \end{aligned}$$

From Gauss Law, we have

$$e_v = \Delta D$$

Therefore,

$$\begin{aligned} \Delta J_d &= \frac{d(\Delta D)}{dt} = \Delta \frac{dD}{dt} \\ \Rightarrow J_d &= \frac{dD}{dt} \quad (3.20) \end{aligned}$$

MAXWELL'S EQUATIONS (Time varying Fields)**Introduction:**

In our study of static fields so far, we have observed that static electric fields are produced by electric charges, static magnetic fields are produced by charges in motion or by steady current. Further, static electric field is a conservative field and has no curl, the static magnetic field is continuous and its divergence is zero. The fundamental relationships for static electric fields among the field quantities can be summarized as:

$$\nabla \times \vec{E} = 0 \quad (1)$$

$$\nabla \cdot \vec{D} = \rho_v \quad (2)$$

For a linear and isotropic medium,

$$\vec{D} = \epsilon \vec{E} \quad (3)$$

Similarly for the magnetostatic case

$$\nabla \cdot \vec{B} = 0 \quad (4)$$

$$\nabla \times \vec{H} = \vec{J} \quad (5)$$

$$\nabla \times \vec{H} = \vec{J} \quad (6)$$

It can be seen that for static case, the electric field vectors \vec{E} and \vec{D} and magnetic field vectors \vec{B} and \vec{H} form separate pairs.

Maxwell's equations represent one of the most elegant and concise ways to state the fundamentals of electricity and magnetism. From them one can develop most of the working relationships in the field. Because of their concise statement, they embody a high level of mathematical sophistication and are therefore not generally introduced in an introductory treatment of the subject, except perhaps as summary relationships.

These basic equations of electricity and magnetism can be used as a starting point for advanced courses, but are usually first encountered as unifying equations after the study of electrical and magnetic phenomena.

Symbols Used

E = Electric field	ρ = charge density	i = electric current
B = Magnetic field	ϵ_0 = permittivity	J = current density
D = Electric displacement	μ_0 = permeability	c = speed of light
H = Magnetic field strength	M = Magnetization	P = Polarization

Integral form in the absence of magnetic or polarizable media:

I. Gauss' law for electricity $\oint \vec{E} \cdot d\vec{A} = \frac{q}{\epsilon_0}$

Gauss' law for magnetism $\oint \vec{B} \cdot d\vec{A} = 0$

III. Faraday's law of induction $\oint \vec{E} \cdot d\vec{s} = -\frac{d\Phi_B}{dt}$

IV. Ampere's law

$$\oint \vec{B} \cdot d\vec{s} = \mu_0 i + \frac{1}{c^2} \frac{\partial}{\partial t} \int \vec{E} \cdot d\vec{A}$$

Differential form in the absence of magnetic or polarizable media:

I. Gauss' law for electricity $\nabla \cdot E = \frac{\rho}{\epsilon_0} = 4\pi k\rho$

Gauss' law for magnetism $\nabla \cdot B = 0$

III. Faraday's law of induction $\nabla \times E = -\frac{\partial B}{\partial t}$

IV. Ampere's law

$$\nabla \times B = \frac{4\pi k}{c^2} J + \frac{1}{c^2} \frac{\partial E}{\partial t}$$

$$= \frac{J}{\epsilon_0 c^2} + \frac{1}{c^2} \frac{\partial E}{\partial t}$$

$$k = \frac{1}{4\pi\epsilon_0} = \text{Coulomb's constant} \quad c^2 = \frac{1}{\mu_0\epsilon_0}$$

Differential form with magnetic and/or polarizable media:

I. Gauss' law for electricity $\nabla \cdot D = \rho$

$$D = \epsilon_0 E + P \quad D = \epsilon_0 E \quad \text{Free space}$$

General case

$$D = \epsilon E \quad \text{Isotropic linear}$$

$$\nabla \cdot B = 0$$

II. Gauss' law for magnetism

III. Faraday's law of induction

$$\nabla \times E = -\frac{\partial B}{\partial t}$$

IV. Ampere's law

$$\nabla \times H = J + \frac{\partial D}{\partial t}$$

$$B = \mu_0(H + M) \quad B = \mu_0 H \quad \text{Free space}$$

General case

$$B = \mu H \quad \text{Isotropic linear magnetic medium}$$

Gauss's Law (Magnetic fields)	Integral form: $\underbrace{\mu_0 \oint \vec{H} \cdot d\vec{S}}_{\text{Left}} = \underbrace{0}_{\text{Right}}$	Left side: The number of magnetic field lines – perpendicularly passing through a closed surface. Right side: Identically zero.	The total magnetic flux passing through any closed surface is zero. Flux enter the closed surface is same with the flux come out from the surface. The divergence of the magnetic field at any point is zero.
	Differential form: $\underbrace{\mu_0 \vec{\nabla} \cdot \vec{H}}_{\text{Left}} = \underbrace{0}_{\text{Right}}$	Left side: Divergence of the magnetic field – the tendency of the field to “flow” away from a point than toward it. Right side: Identically zero.	

Faraday's Law	Integral form: $\underbrace{\oint_C \vec{E} \cdot d\vec{l}}_{\text{Left}} = -\underbrace{\mu_0 \int_S \frac{\partial \vec{H}}{\partial t} \cdot d\vec{S}}_{\text{Right}}$	Left side: The circulation of the vector electric field, \vec{E} around a closed path, C . Right side: The rate of change with time (d/dt) of magnetic field, through any surface, \vec{S} .	Changing magnetic flux through a surface induces an emf in any boundary path, C of that surface, and a changing magnetic field, \vec{H} induces a circulating electric field.
	Differential form: $\underbrace{\vec{\nabla} \times \vec{E}}_{\text{Left}} = -\underbrace{\mu_0 \frac{\partial \vec{H}}{\partial t}}_{\text{Right}}$	Left side: Curl of the electric field, – the tendency of the field lines to circulate around a point. Right side: The rate of change of the magnetic field, \vec{H} over time (d/dt)	

Ampere's Law	<p>Integral form:</p> $\underbrace{\oint_C \vec{H} \cdot d\vec{l}}_{\text{Left}} = \int_S \underbrace{\left(\vec{J}_c + \epsilon_0 \frac{\partial \vec{E}}{\partial t} \right)}_{\text{Right}} \cdot d\vec{S}$	<p>Left side: The circulation of the magnetic field, \vec{H} around a closed path, C.</p> <p>Right side: Two sources for the magnetic field, \vec{H}: a steady conduction current, \vec{J}_c and a changing electric field, \vec{E} through any surface, bounded by closed path, C.</p>	<p>An electric current or a changing electric flux through a surface produces a circulating magnetic field around any path, C that bounds that surface.</p>
	<p>Differential form:</p> $\underbrace{\vec{\nabla} \times \vec{H}}_{\text{Left}} = \underbrace{\vec{J}_c + \epsilon_0 \frac{\partial \vec{E}}{\partial t}}_{\text{Right}}$	<p>Left side: Curl of the magnetic field, – the tendency of the field lines to circulate around a point.</p> <p>Right side: Two terms represent the electric current density, \vec{J}_c and the time rate of change of the electric field, \vec{E}.</p>	<p>A circulating electric field, is produced by a magnetic field, \vec{H} that changes with time.</p> <p>An electric current, or a changing electric field, through a surface produces a circulating magnetic field, \vec{H} around any path that bounds that surface.</p>

Inconsistency of amperes l

Ampere's circuit law states that the line integral of tangential component of H around a closed path is same as the net current I_{enc} enclosed by the path.

i.e.

$$\oint H \cdot dl = I_{enc}$$

By applying stoke's theorem,

$$\oint H \cdot dl \text{ becomes } \int_S J \cdot ds$$

$$\therefore \text{Therefore, } \Delta \times H = J \quad (3.14)$$

This is true in case of static EM fields.

But in case of time-varying fields, the above Ampere's law shows same inconsistency.

The inconsistency of ampere law for time varying fields is shown in two cases:

1. For static EM fields, we have

$$\Delta \times H = J$$

Applying divergence on both sides, we get,

$$\Delta(\Delta \times H) = \Delta J$$

But divergence of curl of a vector field is always zero.

Therefore,

$$\Delta(\Delta \times H) = 0 = \Delta J$$

The continuity of current equation is given by

$$\Delta J = -\frac{dp_v}{dt}$$

Where J = Current density
 e_v = Charge density

For static fields, no current is produced, therefore, $e_v = 0 \Rightarrow \Delta J = 0$

Implies eq. 3.15 is satisfied but for time varying fields, current is produced and therefore,

$$\Delta J = \frac{-de_v}{dt} \neq 0 \quad (3.16)$$

Eq. (3.15) and eq. (3.16) are contradicting each other.

This is an inconsistency of ampere's law and the Ampere's law must be modified for time varying fields.

2. Consider the typical example of where the surface passes between the capacitor plates.

The figure is shown below.

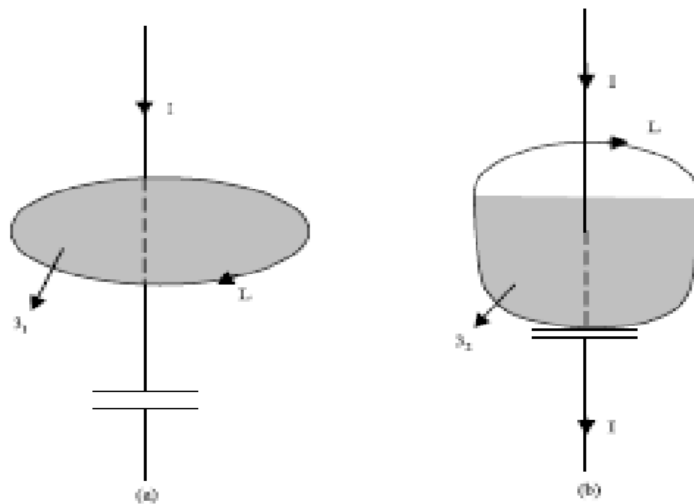

Fig 3.3 (a): Two surfaces of integration which explain the inconsistency of Ampere's law

In fig 3.3(a),

Based on Ampere's circuit law we get figure

$$\int_L H \cdot dl = \int_{S_1} J \cdot ds = I_{enc} = I \quad (3.17)$$

In fig 3.3(b), based the ampere's circuit law, we get,

$$\oint_L H \cdot dl = \int_{S_2} J \cdot ds = I_{enc} = 0 \quad (3.18)$$

Because no conduction current flows through S_2

i.e. $J=0$

in both (a) and (b), same closed path is used, but equations 3.17 and 3.18 are different.

This is an inconsistency of Ampere's circuit law.

This inconsistency of Ampere's circuit law in both cases (1) and (2) can be resolved by including displacement current in Ampere's circuit law.

Substituting in (3.19), we get,

$$\nabla \times H = J + \frac{dD}{dt} \quad (3.21)$$

This is the Maxwell equation (based on ampere's circuit Law) for time varying fields.

In equation (3.21),

J_d = Displacement current density

J = Conduction current density,

The conduction current density J involves flow of charges. The displacement current density J_d does not involve flow of charges.

Displacement current,

$$I_d = \int J_d \cdot ds = \int \frac{dQ}{dt} \cdot ds \quad (3.22)$$

Solved problems:

Problem1:

(a) In a cylindrical conductor to the region $0.01 \leq r \leq 0.02$, $0 < z < 1$ m and the current density is given by,

$$\vec{J} = 10e^{-100r}\hat{a}_\phi \text{ A/m}^2$$

Find the total current crossing the extential of this region with $\phi = \text{constant}$ plane.

(b) Find the total current in a circular conductor of 4 mm radius if the current density varies according to $J = \frac{10^4}{r} \text{ A/m}^2$.

Solution

(a) Total current in the wire is given as,

$$\begin{aligned} I &= \int_S \vec{J} \cdot d\vec{S} = \int_{r=0.01}^{0.02} \int_{z=0}^1 [10e^{-100r}\hat{a}_\phi] \cdot [rdrdz\hat{a}_\phi] \\ &= \int_{r=0.01}^{0.02} \int_{z=0}^1 10re^{-100r} dr dz \\ &= 10 \int_{r=0.01}^{0.02} re^{-100r} dr \\ I &= 10 \left[\frac{re^{-100r}}{-100} \Big|_{0.01}^{0.02} - \int_{r=0.01}^{0.02} \frac{e^{-100r}}{-100} dr \right] \\ &= 10 \left[-\frac{1}{100} (0.02e^{-2} - 0.01e^{-1}) + \frac{e^{-100r}}{-100 \times 100} \Big|_{0.01}^{0.02} \right] \\ &= 2 \times 10^{-3} e^{-1} \\ &= 310^{-3} e^{-2} \end{aligned}$$

(b) Total current is given as,

$$I = \int_S \vec{J} \cdot d\vec{S} = \int_{\phi=0}^{2\pi} \int_{r=0}^{0.004} \frac{10^4}{r} r dr d\phi = 2\pi \times 10^4 \int_{r=0}^{0.004} dr = 2\pi \times 10^4 \times 0.004 = 80\pi \text{ A}$$

Problem2:

If $\vec{J} = \frac{1}{r^3}(2 \cos \theta \hat{a}_r + \sin \theta \hat{a}_\theta)$ A/m², calculate the current passing through

(a) A hemispherical shell of 20 cm radius

(b) A spherical shell of 10 cm radius

Solution

Total current is given as $I = \int \vec{J} \cdot d\vec{S}$

Here, $d\vec{S} = r^2 \sin \theta d\phi d\theta \hat{a}_r$

(a) Total current passing through a hemispherical shell of 20 cm radius is,

$$\begin{aligned} I &= \int_{\theta=0}^{\pi/2} \int_{\phi=0}^{2\pi} \frac{1}{r^3} (2 \cos \theta \hat{a}_r + \sin \theta \hat{a}_\theta) \cdot (r^2 \sin \theta d\phi d\theta \hat{a}_r) \Big|_{r=0.2} \\ &= \int_{\theta=0}^{\pi/2} \int_{\phi=0}^{2\pi} \frac{1}{r^3} 2 \cos \theta r^2 \sin \theta d\phi d\theta \Big|_{r=0.2} \\ &= 2\pi \times \frac{2}{r} \int_{\theta=0}^{\pi/2} \sin \theta d(\sin \theta) \Big|_{r=0.2} \\ &= \frac{4\pi}{0.2} \left[\frac{\sin^2 \theta}{2} \right]_0^{\pi/2} = 10\pi = 31.42 \text{ A} \end{aligned}$$

(b) Total current passing through a spherical shell of 10 cm radius is,

$$\begin{aligned} I &= \int_{\theta=0}^{\pi} \int_{\phi=0}^{2\pi} \frac{1}{r^3} (2 \cos \theta \hat{a}_r + \sin \theta \hat{a}_\theta) \cdot (r^2 \sin \theta d\phi d\theta \hat{a}_r) \Big|_{r=0.1} \\ &= \int_{\theta=0}^{\pi} \int_{\phi=0}^{2\pi} \frac{1}{r^3} 2 \cos \theta r^2 \sin \theta d\phi d\theta \Big|_{r=0.1} \\ &= 2\pi \times \frac{2}{r} \int_{\theta=0}^{\pi} \sin \theta d(\sin \theta) \Big|_{r=0.1} \\ &= \frac{4\pi}{0.1} \left[\frac{\sin^2 \theta}{2} \right]_0^{\pi} \\ &= 0 \end{aligned}$$

Problem3:

For the current density, $\vec{J} = 10z \sin^2 \phi \hat{a}_r$ A/m², find the current through the cylindrical surface of $r = 2$, $1 \leq z \leq 5$ m.

Solution

Total current passing through the cylindrical surface is,

$$\begin{aligned} I &= \int \vec{J} \cdot d\vec{S} = \int_{z=1}^5 \int_{\phi=0}^{2\pi} (10z \sin^2 \phi \hat{a}_r) \cdot (r d\phi dz \hat{a}_r) \Big|_{r=2} = 10r \left[\frac{z^2}{2} \right]_1^5 \int_{\phi=0}^{2\pi} \sin^2 \phi d\phi \Big|_{r=2} \\ &= 10 \times 2 \times \frac{24}{2} \times \frac{2\pi}{2} = 240\pi = 754 \text{ A} \end{aligned}$$

Problem4:

Determine the current density function \vec{J} associated with the magnetic field defined by

(a) $\vec{H} = 3\hat{i} + 7\hat{j} + 2x\hat{k}$ A/m (Cartesian)

(b) $\vec{H} = 6r\hat{a}_r + 2r\hat{a}_\phi + 5\hat{a}_z$ A/m (Cylindrical)

(c) $\vec{H} = 2\rho\hat{a}_\rho + 3\hat{a}_\theta + \cos\theta \hat{a}_\phi$ A/m (Spherical)

(a) $\vec{H} = 3\hat{i} + 7\hat{j} + 2x\hat{k}$

By Ampere's law in Cartesian coordinates,

$$\vec{J} = \nabla \times \vec{H} = \begin{vmatrix} \hat{a}_x & \hat{a}_y & \hat{a}_z \\ \frac{\partial}{\partial x} & \frac{\partial}{\partial y} & \frac{\partial}{\partial z} \\ 3 & 7 & 2x \end{vmatrix} = -2\hat{a}_y \text{ A/m}^2$$

(b) By Ampere's law in cylindrical coordinates,

$$\begin{aligned} \vec{J} &= \nabla \times \vec{H} = \begin{vmatrix} \frac{1}{r}\hat{a}_r & \hat{a}_\phi & \hat{a}_z \\ \frac{\partial}{\partial r} & \frac{\partial}{\partial \phi} & \frac{\partial}{\partial z} \\ H_r & rH_\phi & H_z \end{vmatrix} \\ &= \left[\frac{1}{r} \frac{\partial H_z}{\partial \phi} - \frac{\partial H_\phi}{\partial z} \right] \hat{a}_r + \left[\frac{\partial H_r}{\partial z} - \frac{\partial H_z}{\partial r} \right] \hat{a}_\phi + \frac{1}{r} \left[\frac{\partial(rH_\phi)}{\partial r} - \frac{\partial H_r}{\partial \phi} \right] \hat{a}_z \\ &= \left[\frac{1}{r} \frac{\partial}{\partial \phi} (5) - \frac{\partial}{\partial z} (2r) \right] \hat{a}_r + \left[\frac{\partial}{\partial z} (6r) - \frac{\partial}{\partial r} (5) \right] \hat{a}_\phi + \left(\frac{1}{r} \right) \left[\frac{\partial}{\partial r} (r \cdot 2r) - \frac{\partial}{\partial \phi} (6r) \right] \hat{a}_z \\ &= \left(\frac{1}{r} \right) \times 4r\hat{a}_z \\ &= 4\hat{a}_z \text{ A/m}^2 \end{aligned}$$

(c) $\vec{H} = 2\rho\hat{a}_\rho + 3\hat{a}_\theta + \cos\theta \hat{a}_\phi$

By Ampere's law in spherical coordinates,

$$\begin{aligned} \vec{J} = \nabla \times \vec{H} &= \frac{1}{\rho^2 \sin \theta} \begin{vmatrix} \hat{a}_\rho & \hat{a}_\theta & \hat{a}_\phi \\ \frac{\partial}{\partial \rho} & \frac{\partial}{\partial \theta} & \frac{\partial}{\partial \phi} \\ H_\rho & \rho H_\theta & \rho \sin \theta H_\phi \end{vmatrix} \\ &= \frac{1}{\rho \sin \theta} \left[\frac{\partial}{\partial \theta} (H_\phi \sin \theta) - \frac{\partial H_\theta}{\partial \phi} \right] \hat{a}_\rho + \left(\frac{1}{\rho} \right) \left[\frac{1}{\sin \theta} \frac{\partial H_\rho}{\partial \phi} - \frac{\partial}{\partial \rho} (\rho H_\phi) \right] \hat{a}_\theta \\ &\quad + \frac{1}{\rho} \left[\frac{\partial}{\partial \rho} (\rho H_\theta) - \frac{\partial H_\rho}{\partial \theta} \right] \hat{a}_\phi \\ &= \frac{1}{\rho \sin \theta} \left[\frac{\partial}{\partial \theta} (\cos \theta \sin \theta) - \frac{\partial}{\partial \phi} (3) \right] \hat{a}_\rho + \left(\frac{1}{\rho} \right) \left[\frac{1}{\sin \theta} \frac{\partial}{\partial \phi} (2\rho) - \frac{\partial}{\partial \rho} (\rho \cos \theta) \right] \hat{a}_\theta \\ &\quad + \frac{1}{\rho} \left[\frac{\partial}{\partial \rho} (\rho^3) - \frac{\partial}{\partial \theta} (2\rho) \right] \hat{a}_\phi \\ &= \frac{1}{\rho} \left(\frac{\cos 2\theta}{\sin \theta} \right) \hat{a}_\rho - \frac{1}{\rho} \cos \theta \hat{a}_\theta + \frac{3}{\rho} \hat{a}_\phi \text{ A/m}^2 \end{aligned}$$

Problem7:

The circular loop conductor having a radius of 0.15 m is placed in the xy plane. This loop consists of a resistance of 20Ω as shown in Fig. If the magnetic flux density is

$$\vec{B} = 0.5 \sin 10^3 t \hat{a}_z \text{ T}$$

Find the current flowing through the loop.

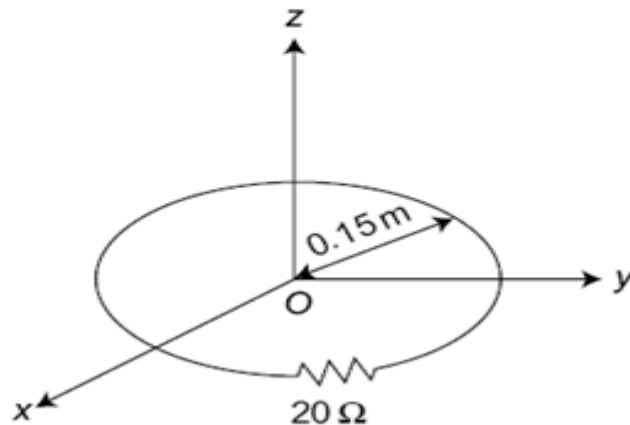

Circular loop conductor

Solution

Here since the loop is stationary and the magnetic field is time only the transformer emf is induced.

varying.

Transformer emf induced is,

$$\begin{aligned}
 V_s &= -\iint_S \frac{\partial \vec{B}}{\partial t} \cdot d\vec{S} = -\iint_S \frac{\partial}{\partial t} (0.5 \sin 10^3 t \hat{a}_z) \cdot (r dr d\phi \hat{a}_z) \\
 &= -0.5 \times 10^3 \cos 10^3 t \int_{r=0}^{0.15} \int_{\phi=0}^{2\pi} r dr d\phi \\
 &= -0.5 \times 2\pi \times 10^3 \cos 10^3 t \left[\frac{r^2}{2} \right]_0^{0.15} \\
 &= -10^3 \pi \cos 10^3 t \times 0.01125 \\
 &= -35.34 \cos 10^3 t \text{ V}
 \end{aligned}$$

UNIT – III

EM WAVE CHARACTERISTICS

Contents:

- Wave Equations for Conducting and Perfect Dielectric Media
- Uniform Plane Waves - Definition, All Relations Between E & H
- Reflection and Refraction of Plane Waves
- Normal incidence for both perfect Conductor and perfect Dielectrics
- Brewster Angle
- Critical Angle
- Total Internal Reflection
- Poynting Vector and Poynting Theorem
- Illustrative Problems.

Wave equations:

The Maxwell's equations in the differential form are

$$\nabla \times \vec{H} = \vec{J} + \frac{\partial \vec{D}}{\partial t}$$

$$\nabla \times \vec{E} = -\frac{\partial \vec{B}}{\partial t}$$

$$\nabla \cdot \vec{D} = \vec{\rho}$$

$$\nabla \cdot \vec{B} = 0$$

Let us consider a source free uniform medium having dielectric constant ϵ , magnetic permeability μ and conductivity σ . The above set of equations can be written as

$$\nabla \times \vec{H} = \sigma \vec{E} + \epsilon \frac{\partial \vec{E}}{\partial t} \quad (5.29(a))$$

$$\nabla \times \vec{E} = -\mu \frac{\partial \vec{H}}{\partial t} \quad (5.29(b))$$

$$\nabla \cdot \vec{E} = 0 \quad (5.29(c))$$

$$\nabla \cdot \vec{H} = 0 \quad (5.29(d))$$

Using the vector identity ,

$$\nabla \times \nabla \times \vec{A} = \nabla \cdot (\nabla \cdot \vec{A}) - \nabla^2 \vec{A}$$

We can write from 2

$$\begin{aligned} \nabla \times \nabla \times \vec{E} &= \nabla \cdot (\nabla \cdot \vec{E}) - \nabla^2 \vec{E} \\ &= -\nabla \times \left(\mu \frac{\partial \vec{H}}{\partial t} \right) \end{aligned}$$

Substituting $\nabla \times \vec{H}$ from 1

$$\nabla \cdot (\nabla \cdot \vec{E}) - \nabla^2 \vec{E} = -\mu \frac{\partial}{\partial t} \left(\sigma \vec{E} + \epsilon \frac{\partial \vec{E}}{\partial t} \right)$$

But in source free($\nabla \cdot \vec{E} = 0$) medium (eq3)

$$\nabla^2 \vec{E} = \mu \sigma \frac{\partial \vec{E}}{\partial t} + \mu \epsilon \frac{\partial^2 \vec{E}}{\partial t^2}$$

In the same manner for equation eqn 1

$$\begin{aligned} \nabla \times \nabla \times \vec{H} &= \nabla \cdot (\nabla \cdot \vec{H}) - \nabla^2 \vec{H} \\ &= \sigma (\nabla \times \vec{E}) + \epsilon \frac{\partial}{\partial t} (\nabla \times \vec{E}) \\ &= \sigma \left(-\mu \frac{\partial \vec{H}}{\partial t} \right) + \epsilon \frac{\partial}{\partial t} \left(-\mu \frac{\partial \vec{H}}{\partial t} \right) \end{aligned}$$

Since $\nabla \cdot \vec{H} = 0$ from eqn 4, we can write

$$\nabla^2 \vec{H} = \mu \sigma \left(\frac{\partial \vec{H}}{\partial t} \right) + \mu \epsilon \left(\frac{\partial^2 \vec{H}}{\partial t^2} \right)$$

These two equations

$$\nabla^2 \vec{E} = \mu\sigma \frac{\partial \vec{E}}{\partial t} + \mu\epsilon \frac{\partial^2 \vec{E}}{\partial t^2}$$

$$\nabla^2 \vec{H} = \mu\sigma \left(\frac{\partial \vec{H}}{\partial t} \right) + \mu\epsilon \left(\frac{\partial^2 \vec{H}}{\partial t^2} \right)$$

are known as wave equations.

Uniform plane waves:

A uniform plane wave is a particular solution of Maxwell's equation assuming electric field (and magnetic field) has same magnitude and phase in infinite planes perpendicular to the direction of propagation. It may be noted that in the strict sense a uniform plane wave doesn't exist in practice as creation of such waves are possible with sources of infinite extent. However, at large distances from the source, the wave front or the surface of the constant phase becomes almost spherical and a small portion of this large sphere can be considered to plane. The characteristics of plane waves are simple and useful for studying many practical scenarios

Let us consider a plane wave which has only E_x component and propagating along z . Since the plane wave will have no variation along the plane perpendicular to z

i.e., xy plane, $\frac{\partial E_x}{\partial x} = \frac{\partial E_x}{\partial y} = 0$. The Helmholtz's equation reduces to,

$$\frac{d^2 E_x}{dz^2} + k^2 E_x = 0$$

The solution to this equation can be written as

$$E_x(z) = E_x^+(z) + E_x^-(z)$$

$$= E_0^+ e^{-jkz} + E_0^- e^{jkz}$$

E_0^+ & E_0^- are the amplitude constants (can be determined from boundary conditions).

In the time domain, $\epsilon_x(z,t) = \text{Re}(E_x(z)e^{j\omega t})$

$$\epsilon_x(z,t) = E_0^+ \cos(\omega t - kz) + E_0^- \cos(\omega t + kz)$$

assuming E_0^+ & E_0^- are real constants.

Here, $\epsilon_x^+(z,t) = E_0^+ \cos(\omega t - \beta z)$ represents the forward traveling wave. The plot of $\epsilon_x^+(z,t)$ for several values of t is shown in the Figure below

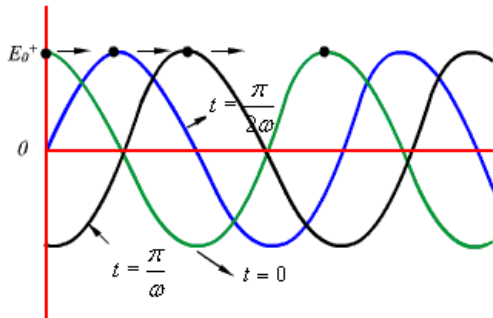

Figure : Plane wave traveling in the + z direction

As can be seen from the figure, at successive times, the wave travels in the +z direction.

If we fix our attention on a particular point or phase on the wave (as shown by the dot) i.e. ,
 $\omega t - kz = \text{constant}$

Then we see that as t is increased to $t + \Delta t$, z also should increase to $z + \Delta z$ so that
 $\omega(t + \Delta t) - k(z + \Delta z) = \text{constant} = \omega t - \beta z$

$$\text{Or, } \omega \Delta t = k \Delta z$$

$$\frac{\Delta z}{\Delta t} = \frac{\omega}{k}$$

$$\text{Or, } \frac{\Delta z}{\Delta t} = \frac{\omega}{k}$$

When $\Delta t \rightarrow 0$,

$$\text{we write } \lim_{\Delta t \rightarrow 0} \frac{\Delta z}{\Delta t} = \frac{dz}{dt} = \text{phase velocity } v_p .$$

$$\therefore v_p = \frac{\omega}{k}$$

If the medium in which the wave is propagating is free space i.e., $\epsilon = \epsilon_0$, $\mu = \mu_0$

$$\text{Then } v_p = \frac{\omega}{\omega \sqrt{\mu_0 \epsilon_0}} = \frac{1}{\sqrt{\mu_0 \epsilon_0}} = C$$

Where 'C' is the speed of light. That is plane EM wave travels in free space with the speed of light.

The wavelength λ is defined as the distance between two successive maxima (or minima or any other reference points).

$$\text{i.e., } (\omega t - kz) - [\omega t - k(z + \lambda)] = 2\pi$$

or,

$$k\lambda = 2\pi$$

$$\text{or, } \lambda = \frac{2\pi}{k}$$

or,

$$\text{Substituting } k = \frac{\omega}{v_p}, \quad \lambda = \frac{2\pi v_p}{2\pi f} = \frac{v_p}{f}$$

$$\text{or, } \lambda f = v_p$$

Thus wavelength λ also represents the distance covered in one oscillation of the wave. Similarly, $\vec{E}^-(z,t) = E_0^- \cos(\omega t + kz)$ represents a plane wave traveling in the -z direction.

The associated magnetic field can be found as follows:

From (6.4),

$$\vec{E}_x^+(z) = E_0^+ e^{-jkz} \hat{a}_x$$

$$\vec{H} = -\frac{1}{j\omega\mu} \nabla \times \vec{E}$$

$$= -\frac{1}{j\omega\mu} \begin{vmatrix} \hat{a}_x & \hat{a}_y & \hat{a}_z \\ 0 & 0 & \frac{\partial}{\partial z} \\ E_0^+ e^{-jkz} & 0 & 0 \end{vmatrix}$$

$$= \frac{k}{\omega\mu} E_0^+ e^{-jkz} \hat{a}_y$$

$$= \frac{E_0^+}{\eta} e^{-jkz} \hat{a}_y = H_0^+ e^{-jkz} \hat{a}_y$$

where $\eta = \frac{\omega\mu}{k} = \frac{\omega\mu}{\omega\sqrt{\mu\epsilon}} = \sqrt{\frac{\mu}{\epsilon}}$ is the intrinsic impedance of the medium.

When the wave travels in free space

$$\eta_0 = \sqrt{\frac{\mu_0}{\epsilon_0}} \cong 120\pi = 377\Omega$$

is the intrinsic impedance of the free space.

In the time domain,

$$\vec{H}^+(z,t) = \hat{a}_y \frac{E_0^+}{\eta} \cos(\omega t - \beta z)$$

Which represents the magnetic field of the wave traveling in the +z direction.

For the negative traveling wave,

$$\vec{H}^-(z,t) = -\hat{a}_y \frac{E_0^+}{\eta} \cos(\omega t + \beta z)$$

For the plane waves described, both the E & H fields are perpendicular to the direction of propagation, and these waves are called TEM (transverse electromagnetic) waves.

The E & H field components of a TEM wave is shown in Fig below

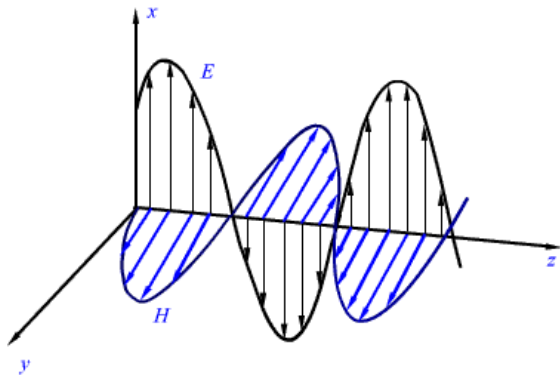

Figure : E & H fields of a particular plane wave at time t.

Solved Problems:

- The vector amplitude of an electric field associated with a plane wave that propagates in the negative z direction in free space is given by $\hat{E}_m = 2a_x + 3a_y$ V/m. Find the magnetic field strength.

Solution:

The direction of propagation \mathbf{n}_β is $-\mathbf{a}_z$. The vector amplitude of the magnetic field is then given

$$\text{by } \hat{H}_m = \frac{n_\beta \wedge \hat{E}}{\eta} = \frac{1}{\eta_0} \begin{vmatrix} a_x & a_y & a_z \\ 0 & 0 & -1 \\ 2 & 3 & 0 \end{vmatrix} = \left(\frac{1}{377} 3a_x - 2a_y \right) A/m$$

*note $\eta_0 = \sqrt{\frac{\mu_0}{\epsilon_0}} = 120\pi \approx 377 \Omega$ (Appendix D – Table D.1)

- The phasor electric field expression in a phase is given by

$$\hat{E} = [a_x + \hat{E}_y a_y + (2 + j5)a_z] e^{-j2.3(-0.6x + 0.8y)}$$

Find the following:

- \hat{E}_y .
- Vector magnetic field, assuming $\mu = \mu_0$ and $\epsilon = \epsilon_0$.
- Frequency and wavelength of this wave.

Solution:

1. The general expression for a uniform plane wave propagating in an arbitrary direction is given by

$$\hat{E} = \hat{E}_m e^{-j\beta \cdot r}$$

where the amplitude vector \hat{E}_m , in general, has components in the x, y, and z directions. Comparing equation 6.3 with the general field equation for the plane wave propagating in an arbitrary direction, we obtain

$$\begin{aligned}\beta \cdot r &= \beta_x x + \beta_y y + \beta_z z \\ &= \beta (\cos \theta_x x + \cos \theta_y y + \cos \theta_z z) \\ &= 2.3(-0.6x + 0.8y + 0)\end{aligned}$$

Hence, a unit vector in the direction of propagation \mathbf{n}_β is given by

$$\mathbf{n}_\beta = -0.6\mathbf{a}_x + 0.8\mathbf{a}_y.$$

Because the electric field \hat{E} must be perpendicular to the direction of propagation \mathbf{n}_β , it must satisfy the following relations:

$$\mathbf{n}_\beta \cdot \hat{E} = 0$$

$$\text{Therefore, } (-0.6\mathbf{a}_x + 0.8\mathbf{a}_y) \cdot [a_x + \hat{E}_y a_y + (2 + j5)a_z] = 0$$

Or

$$-0.6 + 0.8\hat{E}_y = 0$$

Hence, $\hat{E}_y = 0.75$. The electric field is given by

$$\hat{E} = [a_x + \hat{E}_y a_y + (2 + j5)a_z] e^{-j2.3(-0.6x + 0.8y)}$$

2. The vector magnetic field \hat{H} is given by

$$\hat{H} = \frac{1}{\eta} \mathbf{n}_\beta \wedge \hat{E} = \frac{1}{377} \begin{vmatrix} a_x & a_y & a_z \\ -0.6 & 0.8 & 0 \\ 1 & 0.75 & 2 + j5 \end{vmatrix}$$

so that

$$\hat{H}_x = \frac{0.8(2 + j5)}{377} = (4.24 + j10.6) * 10^{-3}$$

$$\hat{H}_y = \frac{0.6(2 + j5)}{377} = (3.18 - j7.95) * 10^{-3}$$

$$\hat{H}_z = \frac{0.6(0.75) + 0.8}{377} = -3.31 * 10^{-3}$$

The vector magnetic field is then given by

$$\hat{H} = (\hat{H}_x a_x + \hat{H}_y a_y + \hat{H}_z a_z) e^{-j2.3(-0.6x+0.8y)}$$

3. The wavelength λ is given by

$$\lambda = \frac{2\pi}{\beta} = \frac{2\pi}{2.3} = 2.73 \text{ m}$$

and the frequency

$$f = \frac{c}{\lambda} = \frac{3 * 10^8}{2.73} = 0.11 \text{ GHz}$$

Reflection and Refraction at Plane Interface between Two Media:

Figure 6.7 shows two media with electrical properties ϵ_1 and μ_1 in medium 1, and ϵ_2 and μ_2 in medium 2. Here a plane wave incident angle θ_i on a boundary between the two media will be partially transmitted into and partially reflected at the dielectric surface. The transmitted wave is reflected into the second medium, so its direction of propagation is different from the incidence wave. The figure also shows two rays for each the incident, reflected, and transmitted waves. A ray is a line drawn normal to the equiphase surfaces, and the line is along the direction of propagation.

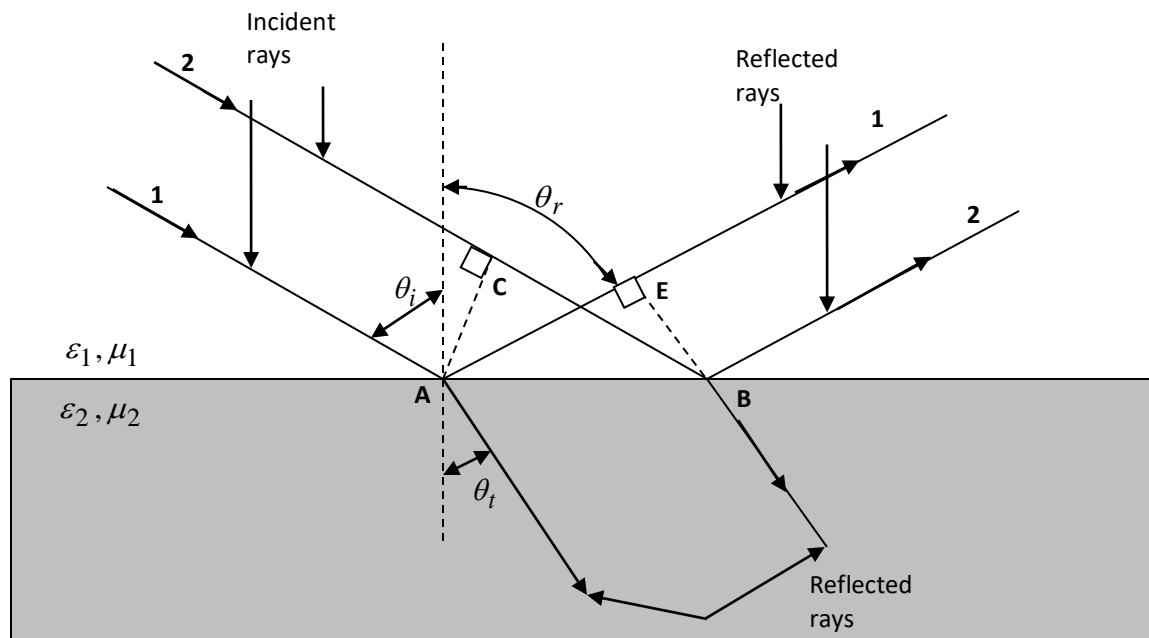

Figure 6.7

The incident ray 2 travels the distance CB , while on the contrary the reflected ray 1 travels the distance AE . For both AC and BE to be the incident and reflected wave fronts or planes of equiphase, the incident wave should take the same time to cover the distance AE . The reason being that the incident and reflected wave rays are located in the same medium, therefore their velocities will be equal,

$$\frac{CB}{V_1} = \frac{AE}{V_1}$$

OR

$$AB \sin \theta_i = AB \sin \theta_r$$

With this being the case then it follows that

$$\theta_i = \theta_r$$

What is the relationship between the angles of incidence θ_i and refraction θ_r ?

It takes the incident ray the equal amount of time to cover distance CB as it takes the refracted ray to cover distance AD –

$$\frac{CB}{V_1} = \frac{AD}{V_2}$$

And the magnitude of the velocity V_1 in medium 1 is:

$$V_1 = \frac{1}{\sqrt{\mu_1 * \epsilon_1}}$$

And in medium 2:

$$V_2 = \frac{1}{\sqrt{\mu_2 * \epsilon_2}}$$

Also,

$$CB = AB \sin \theta_i$$

$$AD = AB \sin \theta_t$$

Therefore,

$$\frac{CB}{AD} = \frac{\sin \theta_i}{\sin \theta_t} = \frac{V_1}{V_2} = \sqrt{\frac{\mu_2 * \epsilon_2}{\mu_1 * \epsilon_1}}$$

For most dielectrics $\mu_2 = \mu_1 = \mu_0$.

Therefore,

$$\frac{\sin \theta_i}{\sin \theta_t} = \sqrt{\frac{\epsilon_2}{\epsilon_1}} \Big|_{\mu_1 = \mu_2 = \mu_0} \quad (6.12)$$

Equation 6.12 is known as Snell's Law of Refraction.

Behavior of Plane waves at the interface of two media:

We have considered the propagation of uniform plane waves in an unbounded homogeneous medium. In practice, the wave will propagate in bounded regions where several values of ϵ, μ, σ will be present. When plane wave travelling in one medium meets a different medium, it is partly reflected and partly transmitted. In this section, we consider wave reflection and transmission at planar boundary between two media.

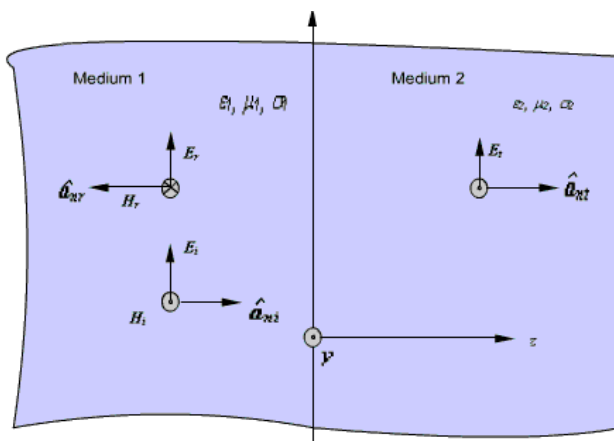

Fig 6 : Normal Incidence at a plane boundary

Case1: Let $z = 0$ plane represent the interface between two media. Medium 1 is characterised by $(\epsilon_1, \mu_1, \sigma_1)$ and medium 2 is characterized by $(\epsilon_2, \mu_2, \sigma_2)$. Let the subscripts 'i' denotes incident, 'r' denotes reflected and 't' denotes transmitted field components respectively. The incident wave is assumed to be a plane wave polarized along x and travelling in medium 1 along \hat{a}_z direction. From equation (6.24) we can write

$$\vec{E}_i(z) = E_{i0} e^{-\gamma_1 z} \hat{a}_x \dots\dots\dots(1)$$

$$\vec{H}_i(z) = \frac{1}{\eta_1} \hat{a}_z \times E_{i0} e^{-\gamma_1 z} \hat{a}_x = \frac{E_{i0}}{\eta_1} e^{-\gamma_1 z} \hat{a}_y \dots\dots\dots(2)$$

where $\gamma_1 = \sqrt{j\omega\mu_1(\sigma_1 + j\omega\epsilon_1)}$ and $\eta_1 = \sqrt{\frac{j\omega\mu_1}{\sigma_1 + j\omega\epsilon_1}}$.

Because of the presence of the second medium at $z = 0$, the incident wave will undergo partial reflection and partial transmission. The reflected wave will travel along \hat{a}_z in medium 1.

The reflected field components are:

$$\vec{E}_r = E_{r0} e^{\gamma_1 z} \hat{a}_x \dots\dots\dots(3)$$

$$\vec{H}_r = \frac{1}{\eta_1} \left(-\hat{a}_z \right) \times E_{r0} e^{\gamma_1 z} \hat{a}_x = -\frac{E_{r0}}{\eta_1} e^{\gamma_1 z} \hat{a}_y \dots\dots\dots(4)$$

The transmitted wave will travel in medium 2 along \hat{a}_z for which the field components are

$$\vec{E}_t = E_{t0} e^{-\gamma_2 z} \hat{a}_x \dots\dots\dots(5)$$

$$\vec{H}_t = \frac{E_{t0}}{\eta_2} e^{-\gamma_2 z} \hat{a}_y \dots\dots\dots(6)$$

where $\gamma_2 = \sqrt{j\omega\mu_2(\sigma_2 + j\omega\epsilon_2)}$ and $\eta_2 = \sqrt{\frac{j\omega\mu_2}{\sigma_2 + j\omega\epsilon_2}}$

In medium 1,

$$\vec{E}_1 = \vec{E}_i + \vec{E}_r \text{ and } \vec{H}_1 = \vec{H}_i + \vec{H}_r$$

and in medium 2,

$$\vec{E}_2 = \vec{E}_t \text{ and } \vec{H}_2 = \vec{H}_t$$

Applying boundary conditions at the interface $z = 0$, i.e., continuity of tangential field components and noting that incident, reflected and transmitted field components are tangential at the boundary, we can write

$$\vec{E}_i(0) + \vec{E}_r(0) = \vec{E}_t(0)$$

$$\& \vec{H}_i(0) + \vec{H}_r(0) = \vec{H}_t(0)$$

From equation 3 to 6 we get,

$$E_{i0} + E_{r0} = E_{t0} \dots\dots\dots(7)$$

$$\frac{E_{i0}}{\eta_1} - \frac{E_{r0}}{\eta_1} = \frac{E_{t0}}{\eta_2} \dots\dots\dots(8)$$

Eliminating E_{t0} ,

$$\frac{E_{i0}}{\eta_1} - \frac{E_{r0}}{\eta_1} = \frac{1}{\eta_2} (E_{i0} + E_{r0})$$

$$\text{or, } E_{i0} \left(\frac{1}{\eta_1} - \frac{1}{\eta_2} \right) = E_{r0} \left(\frac{1}{\eta_1} + \frac{1}{\eta_2} \right)$$

$$\text{or, } E_{r0} = \tau E_{i0}$$

$$\tau = \frac{\eta_2 - \eta_1}{\eta_2 + \eta_1} \dots\dots\dots(8)$$

is called the reflection coefficient.

From equation (8), we can write

$$2E_{i0} = E_{r0} \left[1 + \frac{\eta_1}{\eta_2} \right]$$

$$\text{or, } E_{t0} = \frac{2\eta_2}{\eta_1 + \eta_2} E_{i0} = TE_{i0}$$

$$T = \frac{2\eta_2}{\eta_1 + \eta_2} \dots\dots\dots(9)$$

is called the transmission coefficient.

We observe that,

$$T = \frac{2\eta_2}{\eta_1 + \eta_2} = \frac{\eta_2 - \eta_1 + \eta_1 + \eta_2}{\eta_1 + \eta_2} = 1 + \tau \dots\dots\dots(10)$$

The following may be noted

(i) both τ and T are dimensionless and may be complex

(ii) $0 \leq |\tau| \leq 1$

Let us now consider specific cases:

Case I: Normal incidence on a plane conducting boundary

The medium 1 is perfect dielectric ($\sigma_1 = 0$) and medium 2 is perfectly conducting ($\sigma_2 = \infty$).

$$\therefore \eta_1 = \sqrt{\frac{\mu_1}{\epsilon_1}}$$

$$\eta_2 = 0$$

$$\begin{aligned} \gamma_1 &= \sqrt{(j\omega\mu_1)(j\omega\epsilon_1)} \\ &= j\omega\sqrt{\mu_1\epsilon_1} = j\beta_1 \end{aligned}$$

From (9) and (10)

$$\tau = -1$$

and T = 0

Hence the wave is not transmitted to medium 2, it gets reflected entirely from the interface to the medium 1.

$$\therefore \vec{E}_1(z) = E_{i0}e^{-j\beta_1 z} \hat{a}_x - E_{r0}e^{j\beta_1 z} \hat{a}_x = -2jE_{i0} \sin \beta_1 z \hat{a}_x$$

$$\& \therefore \vec{E}_1(z, t) = \text{Re} \left[-2jE_{i0} \sin \beta_1 z e^{j\omega t} \right] \hat{a}_x = 2E_{i0} \sin \beta_1 z \sin \omega t \hat{a}_x \dots\dots\dots(11)$$

Proceeding in the same manner for the magnetic field in region 1, we can show that,

$$\vec{H}_1(z, t) = \hat{a}_y \frac{2E_{i0}}{\eta_1} \cos \beta_1 z \cos \omega t \dots\dots\dots(12)$$

The wave in medium 1 thus becomes a **standing wave** due to the super position of a forward travelling wave and a backward travelling wave. For a given ' t ', both \vec{E}_1 and \vec{H}_1 vary sinusoidally with distance measured from z = 0. This is shown in figure 6.9.

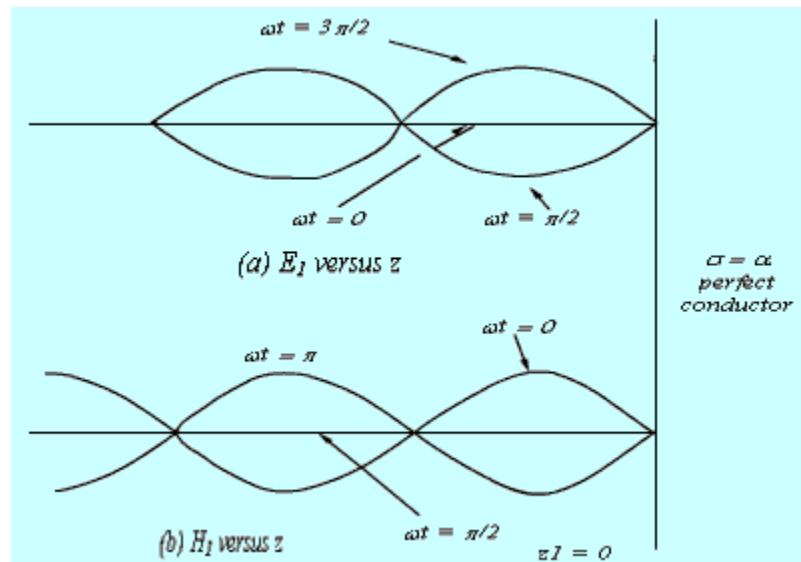

Figure 7: Generation of standing wave

Zeroes of $E_1(z, t)$ and Maxima of $H_1(z, t)$.

Maxima of $E_1(z, t)$ and zeroes of $H_1(z, t)$.

$$\left\{ \begin{array}{l} \text{occur at } \beta_1 z = -n\pi \quad \text{or } z = -n \frac{\lambda}{2} \\ \text{occur at } \beta_1 z = -(2n+1) \frac{\pi}{2} \quad \text{or } z = -(2n+1) \frac{\lambda}{4}, \quad n = 0, 1, 2, \dots \end{array} \right.$$

Case2: Normal incidence on a plane dielectric boundary : If the medium 2 is not a perfect conductor (i.e. $\sigma_2 \neq \infty$) partial reflection will result. There will be a reflected wave in the medium 1 and a transmitted wave in the medium 2. Because of the reflected wave, standing wave is formed in medium 1.

From equation (10) and equation (13) we can write

$$\vec{E}_1 = E_{i0} (e^{-\gamma_1 z} + \Gamma e^{\gamma_1 z}) \hat{a}_x \dots\dots\dots(14)$$

Let us consider the scenario when both the media are dissipation less i.e. perfect dielectrics ($\sigma_1 = 0, \sigma_2 = 0$)

$$\begin{aligned} \gamma_1 &= j\omega\sqrt{\mu_1\epsilon_1} = j\beta_1 & \eta_1 &= \sqrt{\frac{\mu_1}{\epsilon_1}} \\ \gamma_2 &= j\omega\sqrt{\mu_2\epsilon_2} = j\beta_2 & \eta_2 &= \sqrt{\frac{\mu_2}{\epsilon_2}} \end{aligned} \dots\dots\dots(15)$$

In this case both η_1 and η_2 become real numbers.

$$\begin{aligned} \vec{E}_1 &= \hat{a}_x E_{i0} (e^{-j\beta_1 z} + \Gamma e^{j\beta_1 z}) \\ &= \hat{a}_x E_{i0} ((1 + \Gamma) e^{-j\beta_1 z} + \Gamma (e^{j\beta_1 z} - e^{-j\beta_1 z})) \\ &= \hat{a}_x E_{i0} (T e^{-j\beta_1 z} + \Gamma (2j \sin \beta_1 z)) \end{aligned} \dots\dots\dots(16)$$

From (6.61), we can see that, in medium 1 we have a traveling wave component with amplitude TE_{i0} and a standing wave component with amplitude $2JE_{i0}$. The location of the maximum and the minimum of the electric and magnetic field components in the medium 1 from the interface can be found as follows. The electric field in medium 1 can be written as

$$\vec{E}_1 = \hat{a}_x E_{i0} e^{-j\beta_1 z} (1 + \Gamma e^{j2\beta_1 z}) \dots\dots\dots(17)$$

If $\eta_2 > \eta_1$, i.e. $\Gamma > 0$

The maximum value of the electric field is

$$|\vec{E}_1|_{\text{max}} = E_{i0} (1 + \Gamma) \dots\dots\dots(18)$$

and this occurs when

$$2\beta_1 z_{\text{max}} = -2n\pi$$

$$z_{\max} = -\frac{n\pi}{\beta_1} = -\frac{n\pi}{2\pi/\lambda_1} = -\frac{n}{2}\lambda_1$$

or $\dots, n = 0, 1, 2, 3, \dots$(19)

The minimum value of $|\vec{E}_1|$ is

$$|\vec{E}_1|_{\min} = E_{i0}(1 - \Gamma) \dots\dots\dots(20)$$

And this occurs when

$$2\beta_1 z_{\min} = -(2n + 1)\pi$$

or $z_{\min} = -\frac{(2n + 1)\lambda_1}{4}, n = 0, 1, 2, 3, \dots$(21)

For $\eta_2 < \eta_1$ i.e. $\Gamma < 0$

The maximum value of $|\vec{E}_1|$ is $E_{i0}(1 + \Gamma)$ which occurs at the z_{\min} locations and the minimum value of $|\vec{E}_1|$ is $E_{i0}(1 - \Gamma)$ which occurs at z_{\max} locations as given by the equations (6.64) and (6.66).

From our discussions so far we observe that $\frac{|E|_{\max}}{|E|_{\min}}$ can be written as

$$S = \frac{|E|_{\max}}{|E|_{\min}} = \frac{1 + |\Gamma|}{1 - |\Gamma|} \dots\dots\dots(22)$$

The quantity S is called as the standing wave ratio. As $0 \leq |\Gamma| \leq 1$ the range of S is given by $1 \leq S \leq \infty$

From (6.62), we can write the expression for the magnetic field in medium 1 as

$$\vec{H}_1 = \hat{a}_y \frac{E_{i0}}{\eta_1} e^{-j\beta_1 z} (1 - \Gamma e^{j2\beta_1 z}) \dots\dots\dots(23)$$

From (6.68) we find that $|\vec{H}_1|$ will be maximum at locations where $|\vec{E}_1|$ is minimum and vice versa.

In medium 2, the transmitted wave propagates in the + z direction.

Brewster Angle:

Brewster angle is defined as the angle of incidence at which there will be no reflected wave. It occurs when the incident wave is polarized such that the **E** field is parallel to the plane of incidence.

Brewster Angle – (from Brewster’s Law), the polarizing angle of which (when light is incident) the reflected and refracted index is equal to the tangent of the polarizing angle. In other words, the angle of incidence of which there is no reflection.

From the reflection coefficient expression-

$$\hat{\Gamma}_{\parallel} = \frac{\eta_2 \cos \theta_t - \eta_1 \cos \theta_i}{\eta_2 \cos \theta_t + \eta_1 \cos \theta_i}$$

It can be seen that there is an angle of incidence at $\hat{\Gamma}_{\parallel} = 0$. This angle can be obtained when

$$\eta_1 \cos \theta_i = \eta_2 \cos \theta_t$$

Or

$$\cos \theta_i = \frac{\eta_2}{\eta_1} \cos \theta_t$$

The angle of incidence θ_i , at which $\hat{\Gamma}_{\parallel} = 0$, is known as the Brewster angle. The expression for this angle in terms of the dielectric properties of media 1 & 2, considering Snell's Law for the special case $\mu_1 = \mu_2 = \mu_0$ is

$$\frac{\sin \theta_i}{\sin \theta_t} = \frac{V_1}{V_2} \sqrt{\frac{\epsilon_2}{\epsilon_1}} \Big|_{\mu_1 = \mu_2 = \mu_0}$$

This condition is important, because it is usually satisfied by the materials often used in optical applications.

Equation 6.19 will take the form –

$$\cos \theta_i = \sqrt{\frac{\epsilon_1}{\epsilon_2}} \cos \theta_t$$

Square both sides of equation 6.20 and use Snell's Law for the special case of $\mu_1 = \mu_2 = \mu_0$ for the following result:

$$\begin{aligned} \cos^2 \theta_i \frac{\epsilon_1}{\epsilon_2} &= \cos^2 \theta_t = \frac{\epsilon_1}{\epsilon_2} (1 - \sin^2 \theta_t) \\ &= \frac{\epsilon_1}{\epsilon_2} (1 - \sin^2 \theta_i) \end{aligned}$$

The last substitution was based on Snell's Law of refraction. Therefore,

$$(1 - \sin^2 \theta_i) = \frac{\epsilon_1}{\epsilon_2} - \frac{\epsilon_1^2}{\epsilon_2^2} \sin^2 \theta_i$$

$$1 - \frac{\epsilon_1}{\epsilon_2} = \sin^2 \theta_i \left(1 - \frac{\epsilon_1^2}{\epsilon_2^2} \right)$$

And

$$\sin^2 \theta_i = \frac{\epsilon_2}{\epsilon_2 + \epsilon_1}$$

The Brewster angle of incidence is

$$\sin \theta_i = \sqrt{\frac{\epsilon_2}{\epsilon_2 + \epsilon_1}}$$

A specific value of θ_i can be obtained from equation 6.21 -

$$1 - \cos^2 \theta_i = \frac{\epsilon_2}{\epsilon_2 + \epsilon_1}$$

Or

$$\cos^2 \theta_i = 1 - \frac{\epsilon_2}{\epsilon_2 + \epsilon_1} = \frac{\epsilon_1}{\epsilon_2 + \epsilon_1} =$$

$$\cos \theta_i = \sqrt{\frac{\epsilon_1}{\epsilon_2 + \epsilon_1}} \quad (6.23)$$

From equations 6.22 & 6.23 -

$$\tan \theta_i = \sqrt{\frac{\epsilon_2}{\epsilon_1}}$$

This specific angle of incidence θ_i is called the Brewster angle θ_β .

$$\theta_\beta = \tan^{-1} \sqrt{\frac{\epsilon_2}{\epsilon_1}}$$

Critical angle:

In geometric optics, at a refractive boundary, the smallest angle of incidence at which total internal reflection occurs. The critical angle is given by

$$\theta_c = \sin^{-1} \left(\frac{n_1}{n_2} \right) ,$$

Where θ_c is the critical angle, n_1 is the refractive index of the less dense medium, and n_2 is the refractive index of the denser medium.

Angle of incidence: The angle between an incident ray and the normal to a reflecting or refracting surface

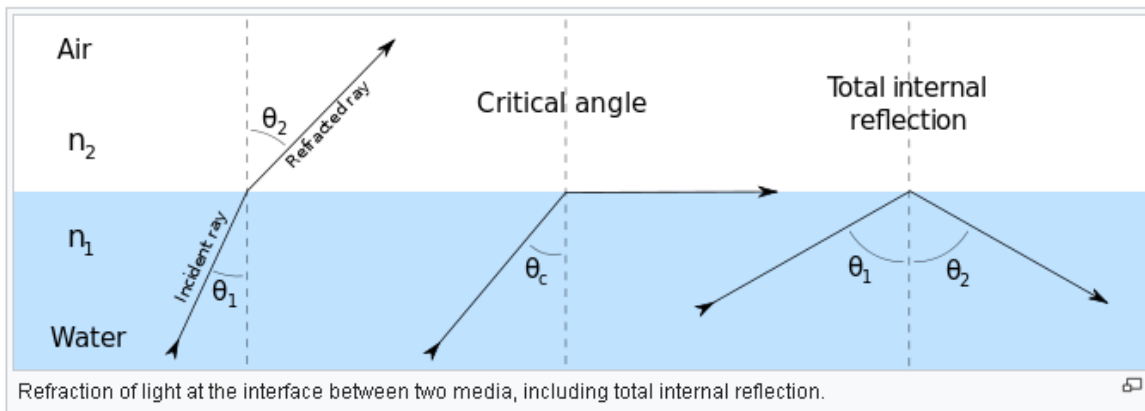

Total Reflection at Critical Angle of Incidence

In the previous section it was shown that for common dielectrics, the phenomenon of total transmission exists only where the electric field is parallel to the plane of incidence known as parallel polarization.

There is a second phenomenon existing for both polarizations:

- Total reflection occurring at the interface between two dielectric media
- A wave passing from a medium with a larger dielectric constant to a medium with smaller value of ϵ

Snell's Law of refraction shows –

$$\frac{\sin \theta_i}{\sin \theta_t} = \sqrt{\frac{\epsilon_2}{\epsilon_1}} \quad \text{or} \quad \sin \theta_t = \frac{\sin \theta_i}{\sqrt{\frac{\epsilon_2}{\epsilon_1}}} \quad (6.26)$$

Therefore, if $\epsilon_1 > \epsilon_2$, and $\theta_t > \theta_i$ then a wave incident at an angle θ_i will pass into medium 2 at a larger angle θ_t .

Definition:

θ_c , (critical angle of incidence) is the value of θ_i that makes $\theta_t = \pi/2$, see Figure 6.13.

Substitute $\theta_t = \pi/2$ in equation 6.26 to get –

$$\sin \theta_c = \sqrt{\frac{\epsilon_2}{\epsilon_1}}, \text{ or } \theta_c = \sin^{-1} \sqrt{\frac{\epsilon_2}{\epsilon_1}}$$

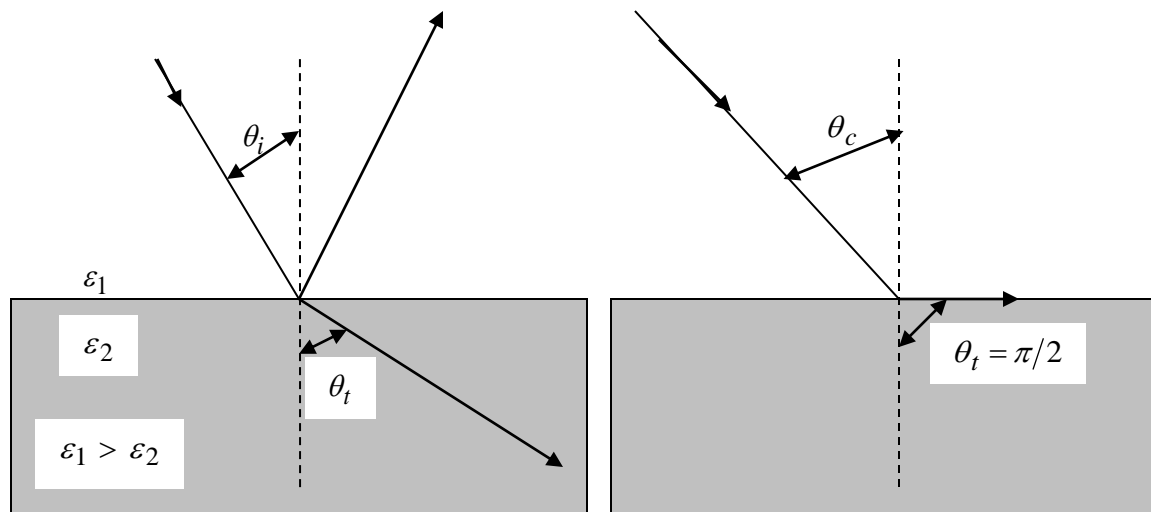

Figure 6.13 illustrates the fact that $\theta_t > \theta_i$, if $\epsilon_1 > \epsilon_2$. The critical angle θ_c is defined as the value of θ_i at which $\theta_t = \pi/2$.

Envision a beam of light impinging on an interface between two transparent media where $n_i < n_t$. At normal incidence ($\theta_i = 0$) most of the incoming light is transmitted into the less dense medium. As θ_i increases, more and more light is reflected back into the dense medium, while θ_t increases. When $\theta_t = 90^\circ$, θ_i is defined to be θ_c and the transmittance becomes zero. For $\theta_i > \theta_c$ all of the light is totally internally reflected, remaining in the incident medium.

Poynting Vector and Power Flow in Electromagnetic Fields:

Electromagnetic waves can transport energy from one point to another point. The electric and magnetic field intensities associated with a travelling electromagnetic wave can be related to the rate of such energy transfer.

Let us consider Maxwell's Curl Equations:

$$\nabla \times \vec{E} = -\frac{\partial \vec{B}}{\partial t}$$

$$\nabla \times \vec{H} = \vec{J} + \frac{\partial \vec{D}}{\partial t}$$

Using vector identity

$$\nabla \cdot (\vec{E} \times \vec{H}) = \vec{H} \cdot \nabla \times \vec{E} - \vec{E} \cdot \nabla \times \vec{H}$$

the above curl equations we can write

$$\nabla \cdot (\vec{E} \times \vec{H}) = -\vec{H} \cdot \frac{\partial \vec{B}}{\partial t} - \vec{E} \cdot \left(\vec{J} + \frac{\partial \vec{D}}{\partial t} \right)$$

$$\text{or, } \nabla \cdot (\vec{E} \times \vec{H}) = -\vec{H} \cdot \frac{\partial \vec{B}}{\partial t} - \vec{E} \cdot \vec{J} - \vec{E} \cdot \frac{\partial \vec{D}}{\partial t} \dots\dots\dots(1)$$

In simple medium where ϵ, μ and σ are constant, we can write

$$\vec{H} \cdot \frac{\partial \vec{B}}{\partial t} = \frac{\partial}{\partial t} \left(\frac{1}{2} \mu H^2 \right)$$

$$\vec{E} \cdot \frac{\partial \vec{D}}{\partial t} = \frac{\partial}{\partial t} \left(\frac{1}{2} \mu E^2 \right) \quad \text{and} \quad \vec{E} \cdot \vec{J} = \sigma E^2$$

$$\therefore \nabla \cdot (\vec{E} \times \vec{H}) = -\frac{\partial}{\partial t} \left(\frac{1}{2} \epsilon E^2 + \frac{1}{2} \mu H^2 \right) - \sigma E^2$$

Applying Divergence theorem we can write,

$$\oint_S (\vec{E} \times \vec{H}) \cdot d\vec{S} = -\frac{\partial}{\partial t} \int_V \left(\frac{1}{2} \epsilon E^2 + \frac{1}{2} \mu H^2 \right) dV - \int_V \sigma E^2 dV \dots\dots\dots(2)$$

The term $\frac{\partial}{\partial t} \int_V \left(\frac{1}{2} \epsilon E^2 + \frac{1}{2} \mu H^2 \right) dV$ represents the rate of change of energy stored in the electric and magnetic fields and the term $\int_V \sigma E^2 dV$ represents the power dissipation within the volume. Hence right hand side of the equation (6.36) represents the total decrease in power within the volume under consideration.

The left hand side of equation (6.36) can be written as $\oint_S (\vec{E} \times \vec{H}) \cdot d\vec{S} = \oint_S \vec{P} \cdot d\vec{S}$ where $\vec{P} = \vec{E} \times \vec{H}$ (W/m^2) is called the Poynting vector and it represents the power density vector associated with the electromagnetic field. The integration of the Poynting vector over any closed surface gives the net power flowing out of the surface. Equation (6.36) is referred to as Poynting theorem and it states that the net power flowing out of a given volume is equal to the time rate of decrease in the energy stored within the volume minus the conduction losses.

Poynting vector for the time harmonic case:

For time harmonic case, the time variation is of the form $e^{j\omega t}$, and we have seen that instantaneous value of a quantity is the real part of the product of a phasor quantity and $e^{j\omega t}$ when $\cos \omega t$ is used as reference. For example, if we consider the phasor

$$\vec{E}(z) = \hat{a}_x E_x(z) = \hat{a}_x E_0 e^{-j\beta z}$$

then we can write the instantaneous field as

$$\vec{E}(z, t) = \text{Re} \left[\vec{E}(z) e^{j\omega t} \right] = E_0 \cos(\omega t - \beta z) \hat{a}_x \dots\dots\dots(1)$$

when E_0 is real.

Let us consider two instantaneous quantities A and B such that

$$A = \text{Re} \left(A e^{j\omega t} \right) = |A| \cos(\omega t + \alpha) \dots\dots\dots(2)$$

$$B = \text{Re} (B e^{j\omega t}) = |B| \cos(\omega t + \beta)$$

where A and B are the phasor quantities.

i.e, $A = |A| e^{j\alpha}$

$$B = |B| e^{j\beta}$$

Therefore,

$$\begin{aligned} AB &= |A| \cos(\omega t + \alpha) |B| \cos(\omega t + \beta) \\ &= \frac{1}{2} |A| |B| [\cos(\alpha - \beta) + \cos(2\omega t + \alpha + \beta)] \end{aligned} \dots\dots\dots(3)$$

Since A and B are periodic with period $T = \frac{2\pi}{\omega}$, the time average value of the product form AB, denoted by \overline{AB} can be written as

$$\begin{aligned} \overline{AB} &= \frac{1}{T} \int_0^T AB dt \\ \overline{AB} &= \frac{1}{2} |A| |B| \cos(\alpha - \beta) \end{aligned} \dots\dots\dots(4)$$

Further, considering the phasor quantities A and B, we find that

$$AB^* = |A| e^{j\alpha} |B| e^{-j\beta} = |A| |B| e^{j(\alpha - \beta)}$$

and $\text{Re} (AB^*) = |A| |B| \cos(\alpha - \beta)$, where * denotes complex conjugate.

$$\therefore \overline{AB} = \frac{1}{2} \text{Re} (AB^*) \dots\dots\dots(5)$$

The poynting vector $\vec{P} = \vec{E} \times \vec{H}$ can be expressed as

$$\vec{P} = \hat{a}_x (E_y H_z - E_z H_y) + \hat{a}_y (E_z H_x - E_x H_z) + \hat{a}_z (E_x H_y - E_y H_x) \dots\dots\dots(6)$$

If we consider a plane electromagnetic wave propagating in +z direction and has only E_x component, from (6.42) we can write:

$$\vec{P}_z = E_x(z,t) H_y(z,t) \hat{a}_z$$

Using (6)

$$\begin{aligned} \vec{P}_{zav} &= \frac{1}{2} \text{Re} \left(E_x(z) H_y^*(z) \hat{a}_z \right) \\ \vec{P}_{zav} &= \frac{1}{2} \text{Re} (E_x(z) \times H_y(z)) \end{aligned} \dots\dots\dots(7)$$

where $\vec{E}(z) = E_x(z) \hat{a}_x$ and $\vec{H}(z) = H_y(z) \hat{a}_y$, for the plane wave under consideration.

For a general case, we can write

$$\vec{P}_{av} = \frac{1}{2} \operatorname{Re}(\vec{E} \times \vec{H}^*) \dots\dots\dots(8)$$

We can define a complex Poynting vector

$$\vec{S} = \frac{1}{2} \vec{E} \times \vec{H}^*$$

and time average of the instantaneous Poynting vector is given by $\vec{P}_{av} = \operatorname{Re}(\vec{S})$.

Solved Problems:

- Calculate the polarization angle (Brewster angle) for an air water ($\epsilon_r = 81$) interface at which plane waves pass from the following:
 - Air into water.
 - Water into air.

SOLUTION

- (a) Air into water:

$$\epsilon_{r1} = 1 \quad \text{and} \quad \epsilon_{r2} = 81$$

The Brewster angle is then given by

$$\theta_\beta = \tan^{-1} \sqrt{\frac{\epsilon_2}{\epsilon_1}} = 6.34^\circ$$

Therefore,

$$\theta_\beta = \tan^{-1} \sqrt{81} = 83.7^\circ$$

- (b) Water into air:

$$\epsilon_{r1} = 81 \quad \text{and} \quad \epsilon_{r2} = 1$$

Hence,

$$\theta_\beta = \tan^{-1} \sqrt{\frac{1}{81}} = 6.34^\circ$$

To relate the Brewster angles in both cases, let us calculate the angle of refraction.

$$\frac{\sin \theta_i}{\sin \theta_t} = \sqrt{\frac{\epsilon_2}{\epsilon_1}}$$

Therefore, in case a,

$$\frac{\sin \theta_B}{\sin \theta_t} = \sqrt{81}$$

Therefore,

$$\sin \theta_t = \frac{\sin 83.7}{9} = 0.11$$

Or $\theta_t = 6.34^\circ$, which is the same as the Brewster angle for case b. Also, the angle of refraction in case b is given by Snell's Law as:

$$\frac{\sin \theta_B}{\sin \theta_t} = \sqrt{\frac{\epsilon_o}{81\epsilon_o}} = \sqrt{\frac{1}{81}}$$

Therefore,

$$\sin \theta_t = \frac{\sin 6.34^\circ}{\sqrt{\frac{1}{81}}} = 0.99$$

Or $\theta_t = 83.7^\circ$, which is the Brewster angle for case a.

2. The index of refraction of liquid is 1.9. What is the critical angle for a light ray travelling in the liquid toward a flat layer of air?

Solution

The critical angle is determined by the following expression (Snell's law, in which the angle of refraction is 90°):

$$n_1 \sin \theta_{cr} = n_2 \sin 90^\circ$$

Here $n_1 = 1.9$ is the index of refraction of medium 1 (liquid), $n_2 = 1$ is the index of refraction of medium 2 (air). We substitute the known values in the above expression and find the critical angle

$$\sin \theta_{cr} = \frac{n_2}{n_1} = \frac{1}{1.9}$$

$$\theta_{cr} = \sin^{-1} \frac{1}{1.9} = 37.36^\circ$$

3. Find the critical angle for total internal reflection for light going from ice (index of refraction = 1.31) into air.

Solution

The critical angle is defined as the angle of incidence for which the corresponding angle of refraction is 90° . Then the Snell's law takes the following form

$$n_1 \sin \theta_{cr} = n_2 \sin \theta_2$$

Here $n_1 = 1.31$ is the index of refraction of medium 1 (ice), θ_{cr} is the unknown critical angle, $\theta_2 = 90^\circ$ is the angle of refraction (angle in air), and $n_2 = 1$ is the index of refraction of medium 2 (air). We substitute these values into above expression and obtain

$$1.31 \sin \theta_{cr} = 1 \sin 90^\circ = 1$$

Then

$$\theta_{cr} = \sin^{-1} \frac{1}{1.31} = 49.76^\circ$$

UNIT – IV
Transmission Lines - I:

Contents:

- Types
- Parameters
- Transmission Line Equations
- Primary & Secondary Constants
- Expressions for Characteristics Impedance, Propagation Constant, Phase and Group Velocities
- Infinite Line Concepts
- Distortion - Condition for Distortion less Transmission and Minimum Attenuation
- Illustrative Problems.

Introduction:

A transmission line is used for the transmission of electrical power from generating substation to the various distribution units. It transmits the wave of voltage and current from one end to another. The transmission line is made up of a conductor having a uniform cross-section along the line. Air act as an insulating or dielectric medium between the conductors.



Fig. Transmission Lines

Types of Transmission Lines

The different types of transmission lines include the following.

Open Wire Transmission Line

It consists pair of parallel conducting wires separated by a uniform distance. The two-wire transmission lines are very simple, low cost and easy to maintain over short distances and these lines are used up to 100 MHz Another name of an open-wire transmission line is a parallel wire transmission line.

Coaxial Transmission Line

The two conductors placed coaxially and filled with dielectric materials such as air, gas or solid. The frequency increases when losses in the dielectric increases, the dielectric is polyethylene. The coaxial cables are used up to 1 GHz. It is a type of wire which carries high-frequency signals with low losses and these cables are used in CCTV systems, digital audios, in computer network connections, in internet connections, in television cables, etc.

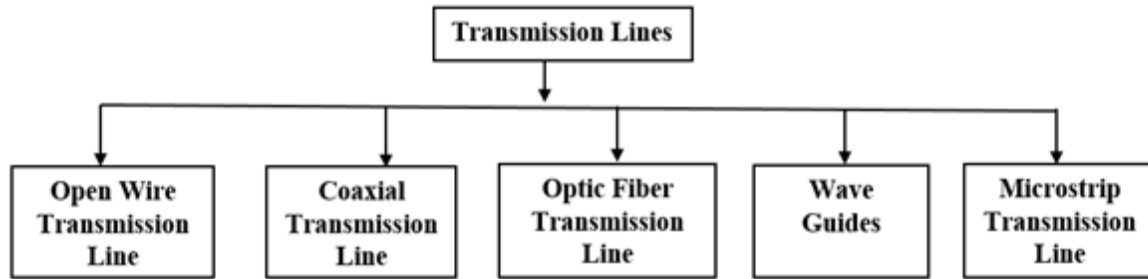

©Eproocus.com

Optic Fiber Transmission Line

The first optical fiber invented by Narender Singh in 1952. It is made-up of silicon oxide or silica, which is used to send signals over a long distance with little loss in signal and at the speed of light. The optic fiber cables used as light guides, imaging tools, lasers for surgeries, used for data transmission and also used in a wide variety of industries and applications.

Microstrip Transmission Lines

The microstrip transmission line is a Transverse Electromagnetic (TEM) transmission line invented by Robert Barrett in 1950.

Wave Guides

Waveguides are used to transmit electromagnetic energy from one place to another place and they are usually operating in dominant mode. The various passive components such as filter, coupler, divider, horn, antennas, tee junction, etc. Waveguides are used in scientific instruments to measure optical, acoustic and elastic properties of materials and objects. There are two types of waveguides are Metal waveguides and dielectric waveguides. The waveguides are used in optical fiber communication, microwave ovens, space crafts, etc.

Applications

The applications of transmission line are

- Power transmission line
- Telephone lines
- Printed circuit board
- Cables
- Connectors (PCI, USB)

Parameters of transmission line (Primary Constants):

The performance of transmission line depends on the parameters of the line. The transmission line has mainly four parameters, resistance, inductance, capacitance and shunt conductance. These parameters are uniformly distributed along the line. Hence, it is also called the distributed parameter of the transmission line.

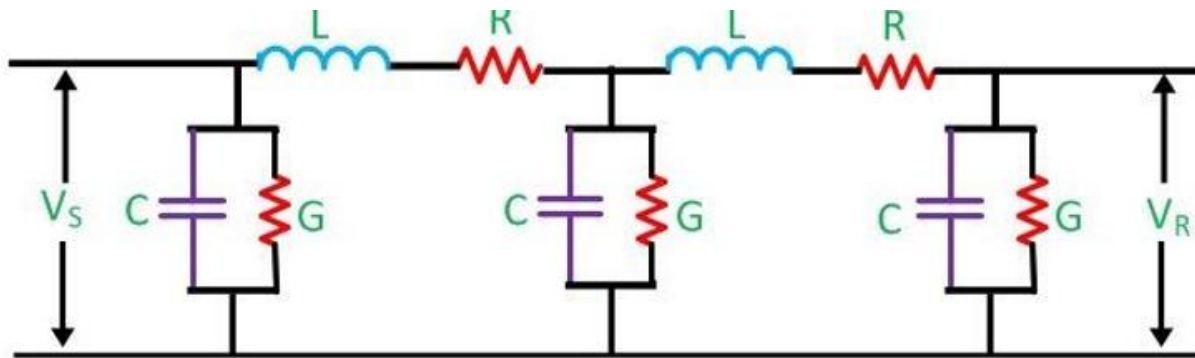

Transmission Line Model

$$Z = R + j\omega L, Y = G + j\omega C$$

The inductance and resistance form series impedance whereas the capacitance and conductance form the shunt admittance. Some critical parameters of transmission line are explained below in detail

Line inductance – The current flow in the transmission line induces the magnetic flux. When the current in the transmission line changes, the magnetic flux also varies due to which emf induces in the circuit. The magnitude of inducing emf depends on the rate of change of flux. Emf produces in the transmission line resist the flow of current in the conductor, and this parameter is known as the inductance of the line.

Line capacitance – In the transmission lines, air acts as a dielectric medium. This dielectric medium constitutes the capacitor between the conductors, which store the electrical energy, or increase the capacitance of the line. The capacitance of the conductor is defined as the present of charge per unit of potential difference.

Capacitance is negligible in short transmission lines whereas in long transmission; it is the most important parameter. It affects the efficiency, voltage regulation, power factor and stability of the system.

Shunt conductance – Air act as a dielectric medium between the conductors. When the alternating voltage applies in a conductor, some current flow in the dielectric medium because of dielectric imperfections. Such current is called leakage current. Leakage current depends on the atmospheric condition and pollution like moisture and surface deposits.

Shunt conductance is defined as the flow of leakage current between the conductors. It is distributed uniformly along the whole length of the line. The symbol Y represented it, and it is measured in Siemens.

Primary & Secondary Constants:

The primary line constants are the resistance, inductance, conductance, and capacitance per unit length of the transmission line.

However, the term “secondary line constants” is not commonly used. It is normally known as “quaternary parameters” or “quaternary constants” used in telecommunication line analysis. These parameters extend the analysis of transmission lines beyond the primary parameters by including additional effects, such as radiation and shunt capacitance. Quaternary parameters are also used to model the behavior of transmission lines at higher frequencies.

Propagation Constant Definition:

Electromagnetic waves propagate in a sinusoidal fashion. **The measure of the change in amplitude and phase per unit distance is called the propagation constant.** Denoted by the Greek letter γ . The terminologies like Transmission function, Transmission constant, Transmission parameter, Propagation coefficient, and Propagation parameter are synonymous with this quantity. Sometimes α and β are collectively referred to as Propagation or Transmission parameters.

The propagation constant can be mathematically expressed as:

$$\gamma = \alpha + j\beta$$

Where:

α (alpha) represents the attenuation constant, which measures the rate of amplitude decay of the signal as it travels through the medium. It is a real number and is usually measured in Nepers per unit length or decibels per unit length.

β (beta) represents the phase constant, which determines the phase shift experienced by the signal as it propagates through the medium. It is an imaginary number and is usually measured in radians per unit length.

The magnitude of the propagation constant (γ) gives the overall rate of signal decay, while the argument or phase angle of the propagation constant ($\arg(\gamma)$) gives the phase shift experienced by the signal.

Propagation Constant of a Transmission Line:

The propagation constant for any conducting lines (like copper lines) can be calculated by relating the primary line parameters.

$$\gamma = \sqrt{ZY}$$

Where, $Z = R + i\omega L$ is the series impedance of line per unit length.

$Y = G + i\omega C$ is the shunt admittance of line per unit length.

Characteristic Impedance (Z_o)

As we already discussed that primary constants are very significant in transmission lines, they make characteristic impedance (Z_o) a very significant parameter as well, because characteristic impedance (Z_o) involves all four of the primary constants in its expression.

What is Characteristic Impedance?

Characteristic impedance can be defined as the ratio of amplitude of voltage to the amplitude of current of a unidirectional wave travelling from source to load along a uniform transmission line in the absence of reflections.

It may also be defined as a square root of the ratio of series impedance of a line to its shunt admittance.

$$Z_o = \sqrt{\frac{Z}{Y}}$$

Where,

$Z = R + j\omega L$ (series impedance per unit length per phase)

$Y = G + j\omega C$ (shunt admittance per unit length per phase)

R, L, G and C are the primary constants of a transmission line, and the above expression confirms that characteristics of a transmission line are described by primary line constants.

Transmission Line Equations

Let us take the equivalent circuit of the transmission line, for this we are going to take the simplest form of transmission line which is two wirelines. These two wirelines are made up of two conductors separated by a dielectric medium usually air medium, which is shown in the below figure

If we pass a current (I) through the conductor-1, will find that there is a magnetic field around the current-carrying wire of a conductor-1 and the magnetic field can be illustrated using series inductor due to the current flow in the conductor-1, there should be a voltage drop across the conductor-1, which can be illustrated by a series of resistance and inductor. The setup of the two-wireline conductor can be made to a capacitor. The capacitor in the figure will always be lossy to illustrate that we have added conductor G. The total setup i.e, series resistance an inductor, parallel capacitor, and conductor make up an equivalent circuit of a transmission line.

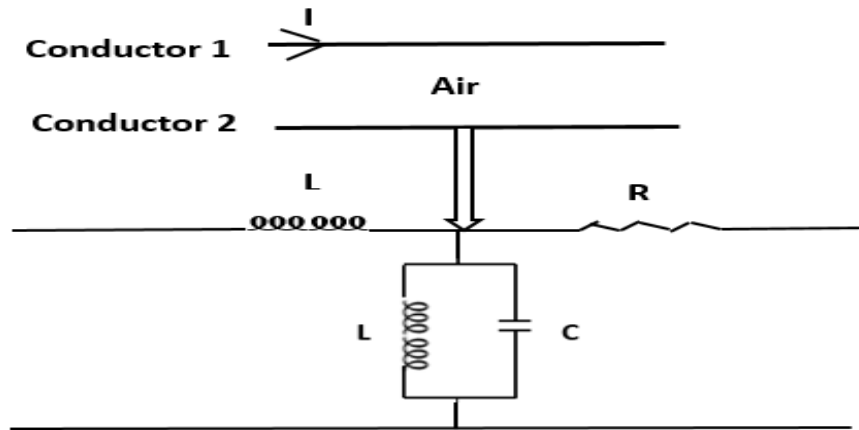

Fig.equivalent_circuit_of_a_transmission_line_1

The inductor and resistance put together in the above figure can be called as series impedance, which is expressed as

$$Z = R + j\omega L$$

The parallel combination of capacitance and conductor n the above figure can be expressed as

$$Y = G + j\omega c$$

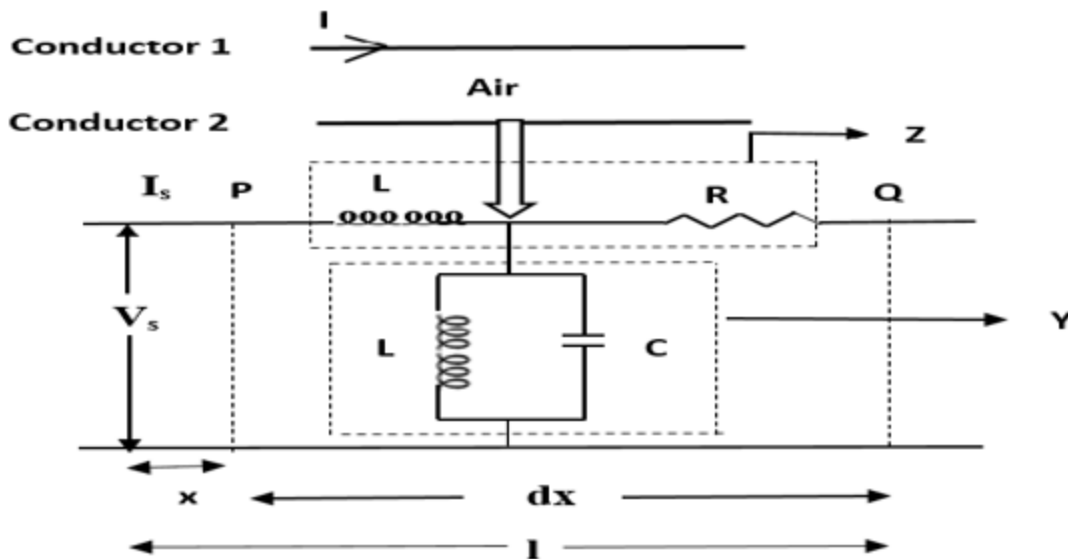

Where l – length

I_s – Sending end current

V_s – Sending end voltage

dx – element length

x – a distance of dx from sending end

At a point, 'p' take current(I) and voltage(v) and at a point, 'Q' take I+dV and V+dV

The change in voltage for the length PQ is the

$$\begin{aligned} V - (V + dV) &= (R + j\omega L) dx * I \\ V - V - dV &= (R + j\omega L) dx * I \\ -dV/dx &= (R + j\omega L) * I \dots\dots\dots \text{eq(1)} \\ I - (I + dI) &= (G + j\omega c) dx * V \\ I - I - dI &= (G + j\omega c) dx * V \\ -dI/dx &= (G + j\omega c) * V \dots\dots\dots \text{eq(2)} \end{aligned}$$

Differentiating eq(1) and (2) with respect to dx will get

$$\begin{aligned} -d^2v/dx^2 &= (R + j\omega L) * dI/dx \dots\dots\dots \text{eq(3)} \\ -d^2I/dx^2 &= (G + j\omega c) * dV/dx \dots\dots\dots \text{eq(4)} \end{aligned}$$

Substituting eq(1) and (2) in eq(3) and (4) will get

$$\begin{aligned} -d^2v/dx^2 &= (R + j\omega L) (G + j\omega c) V \dots\dots\dots \text{eq(5)} \\ -d^2I/dx^2 &= (G + j\omega c) (R + j\omega L) I \dots\dots\dots \text{eq(6)} \\ \text{Let } P^2 &= (R + j\omega L) (G + j\omega c) \dots\dots\dots \text{eq(7)} \end{aligned}$$

Where P – propagation constant

Substitute d/dx = P in eq(6) and (7)

$$\begin{aligned} -d^2v/dx^2 &= P^2V \dots\dots\dots \text{eq(8)} \\ -d^2I/dx^2 &= P^2I \dots\dots\dots \text{eq(9)} \end{aligned}$$

General solution is

$$\begin{aligned} V &= Ae^{Px} + Be^{-Px} \dots\dots\dots \text{eq(10)} \\ I &= Ce^{Px} + De^{-Px} \dots\dots\dots \text{eq(11)} \end{aligned}$$

Where A, B C and D are constants

Differentiating eq(10) and (11) with respect to 'x' will get

$$\begin{aligned} -dv/dx &= P (Ae^{px} - Be^{-px}) \dots\dots\dots \text{eq(12)} \\ -dI/dx &= P (Ce^{px} - De^{-px}) \dots\dots\dots \text{eq(13)} \end{aligned}$$

Substitute eq(1) and (2) in eq(12) and (13) will get

$$\begin{aligned} -(R + j\omega L) * I &= P (Ae^{px} + Be^{-px}) \dots\dots\dots \text{eq(14)} \\ -(G + j\omega c) * V &= P (Ce^{px} + De^{-px}) \dots\dots\dots \text{eq(15)} \end{aligned}$$

Substitute 'p' value in eq(14) and (15) will get

$$\begin{aligned} I &= -p/ R + j\omega L * (Ae^{px} + Be^{-px}) \\ &= \sqrt{G + j\omega c} / R + j\omega L * (Ae^{px} + Be^{-px}) \dots\dots\dots \text{eq(16)} \\ V &= -p/ G + j\omega c * (Ce^{px} + De^{-px}) \\ &= \sqrt{R + j\omega L} / G + j\omega c * (Ce^{px} + De^{-px}) \dots\dots\dots \text{eq(17)} \\ \text{Let } Z_0 &= \sqrt{R + j\omega L} / G + j\omega c \end{aligned}$$

Where Z_0 is the characteristic impedenc

Substitute boundary conditions $x=0$, $V=V_S$ and $I=I_S$ in eq(16) and (17) will get

$$I_S = A+B \dots\dots\dots \text{eq(18)}$$

$$V_S = C+D \dots\dots\dots \text{eq(19)}$$

$$I_S Z_0 = -A+B \dots\dots\dots \text{eq(20)}$$

$$V_S / Z_0 = -C+D \dots\dots\dots \text{eq(21)}$$

From (20) will get A and B values

$$A = V_S - I_S Z_0$$

$$B = V_S + I_S Z_0$$

From eq(21) will get C and D values

$$C = (I_S - V_S / Z_0) / 2$$

$$D = (I_S + V_S / Z_0) / 2$$

Substitute A, B, C and D values in eq(10) and (11)

$$\begin{aligned} V &= (V_S - I_S Z_0) e^{px} + (V_S + I_S Z_0) e^{-px} \\ &= V_S (e^{px} + e^{-px}/2) - I_S Z_0 (e^{px} - e^{-px}/2) \\ &= V_S \cosh x - I_S Z_0 \sinh x \end{aligned}$$

Similarly

$$\begin{aligned} I &= (I_S - V_S / Z_0) e^{px} + (I_S + V_S / Z_0) e^{-px} \\ &= I_S (e^{px} + e^{-px}/2) - V_S / Z_0 (e^{px} - e^{-px}/2) \\ &= I_S \cosh x - V_S / Z_0 \sinh x \end{aligned}$$

Thus $V = V_S \cosh x - I_S Z_0 \sinh x$

$I = I_S \cosh x - V_S / Z_0 \sinh x$

Equation of transmission line in terms of sending end parameters are derived

Phase and Group Velocities:

Phase velocity is the speed at which a point of constant phase moves through a medium. In simple terms, it's like tracing the path of a ruffling wave crest or trough marking a constant phase in the wave.

In physics, phase velocity can be calculated by using the simple formula:

$$v_p = \frac{\omega}{k}$$

Where:

- ω indicates phase velocity
- v_p is the angular frequency of the wave
- k is the wave number

It's worth mentioning that phase velocity depends on the medium the wave passes through. In some media, the phase velocity might change, leading to phenomena such as refraction.

Group Velocity

Group velocity is defined as the derivative of the wave's angular frequency with respect to its wave number. It can be mathematically expressed as:

$$v_g = \frac{d\omega}{dk}$$

Relation Between Group Velocity and Phase Velocity

The Group Velocity and Phase Velocity relation can be mathematically written as-

$$V_g = V_p + k \frac{dV_p}{dk}$$

Where,

- V_g is the group velocity.
- V_p is the phase velocity.
- k is the angular wavenumber.

The group velocity is directly proportional to phase velocity. This means-

- When group velocity increases, proportionately phase velocity will also increase.
- When phase velocity increases, proportionately group velocity will also increase.

For the amplitude of wave packet let-

- ω is the angular velocity given by $\omega=2\pi f$
- k is the angular wave number given by

$$k = \frac{2\pi}{\lambda}$$

- t is time
- x be the position
- V_p phase velocity
- V_g be the group velocity

The phase velocity of a wave is given by the following equation:

$$v_p = \frac{\omega}{k}$$

....(eqn 1)

Rewriting the above equation, we get:

$$\omega = kv_p$$

....(eqn 2)

Differentiating (eqn 2) w.r.t k we obtain,

$$\frac{d\omega}{dk} = v_p + k \frac{dv_p}{dk}$$

....(eqn 3)

As

$$v_g = \frac{d\omega}{dk}$$

(eqn 3) reduces to:

$$v_g = v_p + k \frac{dv_p}{dk}$$

The above equation signifies the relationship between the phase velocity and the group velocity.

Infinite Line Concepts:

A finite line is a line having a finite length on the line. It is a line, which is terminated, in its characteristic impedance ($Z_R=Z_0$), so the input impedance of the finite line is equal to the characteristic impedance ($Z_s=Z_0$).

An infinite line is a line in which the length of the transmission line is infinite. A finite line, which is terminated in its characteristic impedance, is termed as infinite line. So for an infinite line, the input impedance is equivalent to the characteristic impedance.



Figure: infinite line

→ The ratio of the voltage applied to the current flowing will give the input impedance of an infinite line. This input impedance is known as **characteristic impedance** of the line and is denoted by ' Z_0 '.

$$\text{Therefore } Z_0 = \frac{V_{si}}{I_{si}}$$

Where V_{si} is sending end voltage of an infinite line and I_{si} is sending end current of an infinite line.

Current at any point at a distance ' x ' from the sending end is given by

$$I = ce^{px} + de^{-px} \quad \longrightarrow \quad 1$$

The values of ' c ' and ' d ' now determined by considering an infinite line.

The values of ' c ' and ' d ' now determined by considering an infinite line.

At sending of an infinite line $x = 0$ and $I = I_{si}$ applying these conditions we get

$$I_{si} = c + d$$

However at the receiving end of the infinite line $x = \infty$ and $I = 0$.

Applying these conditions to same equation

$$0 = c \times \infty + 0$$

$$c \times \infty = 0$$

Thus either $c = 0$ or $\infty = 0$ but ∞ can not equal to zero.

Therefore $c = 0$

When $c = 0$, $I_{si} = d$

Putting these values in equation (1), we get

$$I = I_{si}e^{-px}$$

This equation gives current at any point of an infinite line.

Similarly the voltage at any point of an infinite line can be given as

$$V = V_{si}e^{-px}$$

Infinite line is equivalent to a finite line terminated in its Z_0 .

- If a finite length of line is joined with a similar kind of infinite line, their total input impedance is the same as that of infinite itself.
- A finite line terminated by its Z_0 , behaves as an infinite line.
- Consider a line of length 'l' terminated in its characteristic impedance Z_0 .

Let the voltage and current at the termination be V_R and I_R respectively.

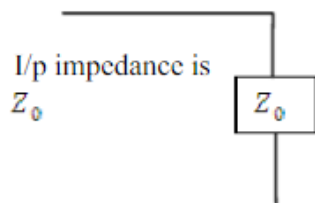
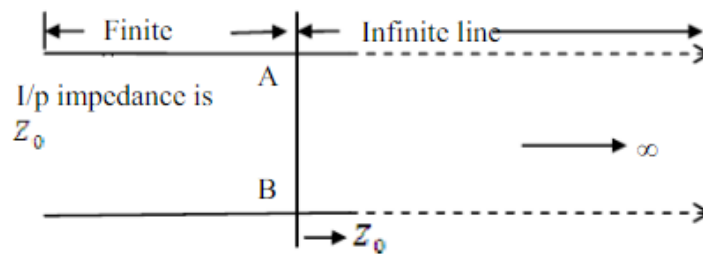

Fig: equivalent of an infinite line.

Therefore $\frac{V_R}{I_R} = Z_0$

We know that voltage and current equations at a point distance 'x' from the sending end in terms of sending end voltage and current is given by

$$v = V_s \cosh Px - I_s Z_0 \sinh Px$$

$$I = -\frac{1}{Z_0} [V_s \sinh Px - I_s Z_0 \cosh Px]$$

At $x = l$, $v = V_R$ and $I = I_R$ we get

$$V_R = V_s \cosh Pl - I_s Z_0 \sinh Pl$$

—————→ 1

$$I_R = -\frac{1}{Z_0} [V_s \sinh Pl - I_s Z_0 \cosh Pl]$$

—————→ 2

By dividing equation (1) and (2)

$$\frac{V_R}{I_R} = -\frac{(V_s \cosh Pl - I_s Z_0 \sinh Pl)}{\frac{1}{Z_0} [V_s \sinh Pl - I_s Z_0 \cosh Pl]}$$

Since $\frac{V_R}{I_R} = Z_0 \Rightarrow 1 = \frac{(V_s \cosh Pl - I_s Z_0 \sinh Pl)}{(I_s Z_0 \cosh Pl - V_s \sinh Pl)}$

$$V_s \cosh Pl - I_s Z_0 \sinh Pl = I_s Z_0 \cosh Pl - V_s \sinh Pl$$

$$V_s (\cosh Pl + \sinh Pl) = I_s Z_0 (\cosh Pl + \sinh Pl)$$

$$\frac{V_s}{I_s} = Z_0$$

But $\frac{V_s}{I_s}$ is the input impedance of the line. Therefore

$$Z_0 = Z_{in}$$

Therefore the input impedance of a finite line terminated in its characteristic impedance Z_0 is the characteristic impedance of line.

By definition the input impedance of an infinite line is the characteristic impedance of the line. Therefore a finite line terminated in its Z_0 , is equivalent to an infinite line as both will have an input impedance Z_0 .

Distortion - Condition for Distortion less Transmission and Minimum Attenuation:

It is desirable, however to know the condition on the line parameters that allows propagation without distortion. The line having parameters satisfy this condition is termed as a distortion less line.

The condition for a distortion less line was first investigated by Oliver Heaviside. Distortion less condition can help in designing new lines or modifying old ones to minimize distortion.

A line, which has neither frequency distortion nor phase distortion is called a distortion less line.

Condition for a distortion less line

The condition for a distortion less line is $RC=LG$. Also,

- a) The attenuation constant α should be made independent of frequency. $\alpha = RG$
- b) The phase constant β should be made dependent of frequency. $\beta = \omega LC$
- c) The velocity of propagation is independent of frequency.

$$V=1 / LC$$

For the telephone cable to be distortion less line, the inductance value should be increased by placing lumped inductors along the line.

For a perfect line, the resistance and the leakage conductance value were neglected. The conditions for a perfect line are $R=G=0$. Smooth line is one in which the load is terminated by its characteristic impedance and no reflections occur in such a line. It is also called as flat line.

The distortion Less Iine

If a line is to have neither frequency nor delay distortion, then attenuation constant and velocity of propagation cannot be function of frequency.

Then the phase constant be a direct function of frequency

$$\beta = \sqrt{\frac{\omega^2 LC - RG + \sqrt{(RG - \omega^2 LC) + \omega^2 (LG + CR)}}{2}}$$

The above equation shows that if the the term under the second radical be reduced to equal $(RG + \omega^2 LC)^2$

Then the required condition for β is obtained. Expanding the term under the internal radical and forcing the equality gives

$$R^2G^2 - 2\omega^2LCRG + \omega^4L^2C^2 + \omega^2L^2G^2 + 2\omega^2LCRG + \omega^2CR^2 = (RG + \omega^2LC)^2$$

This reduces to

$$2\omega^2LCRG + \omega^2L^2G^2 + \omega^2CR^2 = 0$$

$$(LG - CR)^2 = 0$$

Therefore, the condition that will make phase constant a direct form is

$$LG = CR$$

A hypothetical line might be built to fulfill this condition. The line would then have a value of β obtained by use of the above equation.

Already we know that the formula for the phase constant

$$\beta = \omega LC$$

Then the velocity of propagation will be $v = 1/LC$

This is the same for the all frequencies, thus eliminating the delay distortion.

May be made independent of frequency if the term under the internal radical is forced to reduce to $(RG + \omega LC)^2$

Analysis shows that the condition for the distortion less line $LG = CR$, will produce the desired result, so that it is possible to make attenuation constant and velocity independent of frequency simultaneously. Applying the condition $LG = RC$ to the expression for the attenuation gives $\alpha = RG$

This is the independent of frequency, thus eliminating frequency distortion on a line. To achieve

$$LG = CR$$

Require a very large value of L, since G is small. If G is intentionally increased, attenuation are increased, resulting in poor line efficiency.

To reduce R raises the size and cost of the conductors above economic limits, so that the hypothetical results cannot be achieved.

Propagation constant is as the natural logarithm of the ratio of the sending end current or voltage to the receiving end current or voltage of the line. It gives the manner in the wave is propagated along a line and specifies the variation of voltage and current in the line as a function of distance. Propagation constant is a complex quantity and is expressed as $\gamma = \alpha + j\beta$.

The real part is called the attenuation constant, whereas the imaginary part of propagation constant is called the phase constant.

UNIT-V
Transmission Lines - II:

Contents:

- SC and OC Lines
- Input Impedance Relations
- Reflection Coefficient
- VSWR
- Smith Chart - Configuration and Applications
- Illustrative Problems.

Input Impedance Relations

- The input impedance of a transmission line is the impedance seen by any signal entering it. It is caused by the physical dimensions of the transmission line and its downstream circuit elements.
- If a transmission line is ideal, there is no attenuation to the signal amplitudes and the propagation constant turns out to be purely imaginary.
- When the transmission line length is infinite, the input impedance is equal to the characteristic impedance.

Calculating the Input Impedance

Consider a lossless, high-frequency transmission line where the voltage and currents are given by equations 1 and 2, with the input impedance, characteristic impedance, and load impedance as Z_{in} , Z_0 , and Z_L , respectively.

$$V(z) = V^+ \left(e^{-j\beta z} + \Gamma e^{j\beta z} \right) \quad (1)$$

$$I(z) = \frac{V^+}{Z_0} \left(e^{-j\beta z} - \Gamma e^{j\beta z} \right) \quad (2)$$

Γ - Reflection coefficient

As the transmission line is ideal, there is no attenuation to the signal amplitudes and the propagation constant turns out to be purely imaginary. Let's define the output terminals with axis point $z=0$ and input terminals $z=-L$. Our objective is to find the impedance of the circuit when looking from $Z=-L$:

$$Z_{in}(z) = \frac{V(z)}{I(z)} = \frac{V^+ \left(e^{-j\beta z} + \Gamma e^{j\beta z} \right)}{V^+ \left(e^{-j\beta z} - \Gamma e^{j\beta z} \right)} Z_0 \quad (3)$$

$$Z_{in}(z) = \left[\frac{e^{-j\beta z} + \Gamma e^{j\beta z}}{e^{-j\beta z} - \Gamma e^{j\beta z}} \right] Z_0 \quad (4)$$

The input impedance is the ratio of input voltage to the input current and is given by equation 3. By substituting equation 5 into equation 4, we can obtain the input impedance, as given in equation 6:

$$\Gamma = \frac{Z_L - Z_0}{Z_0 + Z_L} \quad (5)$$

$$Z_{in}(-L) = Z_0 \left[\frac{Z_L + jZ_0 \tan(\beta L)}{Z_0 + jZ_L \tan(\beta L)} \right] \quad (6)$$

From equation 6, we can conclude that the input impedance of the [transmission line](#) depends on the load impedance, characteristic impedance, length of the transmission line, and the phase constant of the signals propagating through it.

It is already a known fact that the characteristic impedance Z_0 is dependent on the distributed parameters of the transmission line, such as resistance, inductance, capacitance, and conductance (as given by equation 7), which are usually defined per unit length. Whenever any change is made in the circuit, the input impedance changes.

$$Z_0 = \sqrt{\frac{R + j\omega L}{G + j\omega C}} \quad (7)$$

The relationship between the characteristic impedance and input impedance can be deduced for certain [transmission lines](#). In the derivation of the input impedance equation, we have considered the finite length of the transmission line. When the transmission line length is infinite, then the input impedance of the transmission line is equal to the characteristic impedance. Whenever the transmission line of finite length is terminated by a load impedance that is equal to the characteristic impedance, there is no reflection of signals (according to equation 7). In this case, the input impedance equals characteristic impedance.

OPEN AND SHORT-CIRCUITED LINES

As limited cases it is convenient to consider lines terminated in open circuit or short circuit, that is with $Z_R = \infty$ or $Z_R = 0$.

First, let us consider the question at hand: What is the input impedance when the transmission line is open- or short-circuited?

For a short circuit, $Z_L = 0$, $\Gamma = -1$, so we find

$$\begin{aligned} Z_{in}(l) &= Z_0 \frac{1 + \Gamma e^{-j2\beta l}}{1 - \Gamma e^{-j2\beta l}} \\ &= Z_0 \frac{1 + e^{-j2\beta l}}{1 - e^{-j2\beta l}} \end{aligned} \quad (3.16.1)$$

Multiplying numerator and denominator by $e^{+j\beta l}$, we obtain

$$Z_{in}(l) = Z_0 \frac{e^{+j\beta l} - e^{-j\beta l}}{e^{+j\beta l} + e^{-j\beta l}} \quad (3.16.2)$$

Now we invoke the following trigonometric identities:

$$\cos \theta = \frac{1}{2} [e^{+j\theta} + e^{-j\theta}] \quad (3.16.3)$$

$$\sin \theta = \frac{1}{j2} [e^{+j\theta} - e^{-j\theta}] \quad (3.16.4)$$

Employing these identities, we obtain:

$$Z_{in}(l) = Z_0 \frac{j2 (\sin \beta l)}{2 (\cos \beta l)} \quad (3.16.5)$$

and finally:

$$\boxed{Z_{in}(l) = +jZ_0 \tan \beta l} \quad (3.16.6)$$

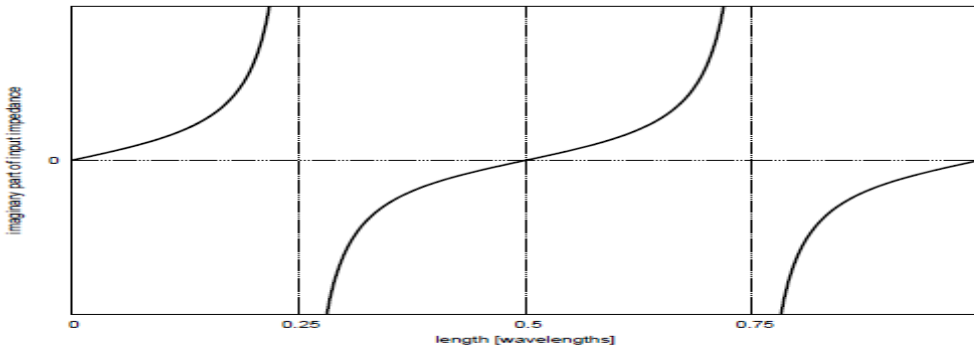
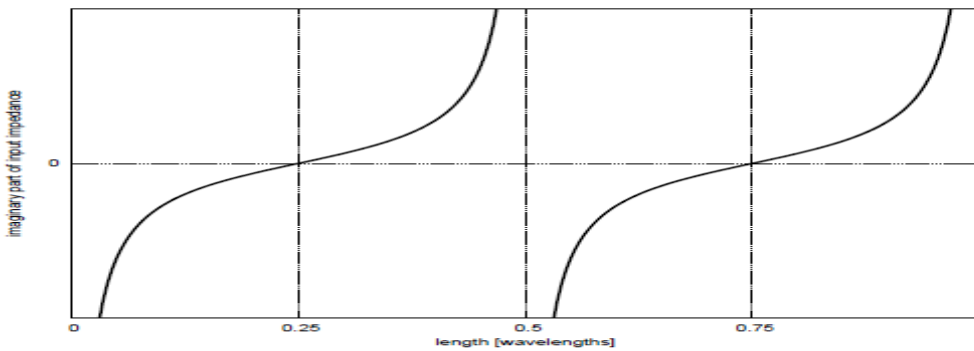
(a) Short-circuit termination ($Z_L = 0$).(b) Open-circuit termination ($Z_L \rightarrow \infty$).

(b) Open-circuit termination ($Z_L \rightarrow \infty$).

For an open circuit termination, $Z_L \rightarrow \infty$, $\Gamma = +1$, and we find

$$\begin{aligned} Z_{in}(l) &= Z_0 \frac{1 + \Gamma e^{-j2\beta l}}{1 - \Gamma e^{-j2\beta l}} \\ &= Z_0 \frac{1 + e^{-j2\beta l}}{1 - e^{-j2\beta l}} \end{aligned} \quad (3.16.7)$$

Following the same procedure detailed above for the short-circuit case, we find

$$\boxed{Z_{in}(l) = -j Z_0 \cot \beta l} \quad (3.16.8)$$

Figure 3.16.1 (b) shows the result for open-circuit termination. As expected, $Z_{in} \rightarrow \infty$ for $l = 0$, and the same $\lambda/2$ periodicity is observed. What is of particular interest now is that at $l = \lambda/4$ we see $Z_{in} = 0$. In this case, the transmission line has transformed the *open* circuit termination into a *short* circuit.

And for the short circuit case $Z_R = 0$, so that

$$Z_s = Z_0 \tanh \gamma l$$

Before the open circuit case is considered, the input impedance should be written. The input impedance of the open circuited line of length l , with $Z_R = \infty$, is

$$Z_{oc} = Z_0 \coth \gamma l$$

By multiplying the above two equations it can be seen that

$$Z_0 = Z_{oc} Z_{sc}$$

This is the same result as was obtained for a lumped network. The above equation supplies a very valuable means of experimentally determining the value of Z_0 of a line.

Also from the same two equations

$$\begin{aligned} \tanh \gamma l &= \sqrt{\frac{Z_{sc}}{Z_{oc}}} \\ \gamma l &= \tanh^{-1} \sqrt{\frac{Z_{sc}}{Z_{oc}}} \end{aligned}$$

Use of this equation in experimental work requires the determination of the hyperbolic tangent of a complex angle. If

Reflection coefficient:

A reflection coefficient, sometimes called reflection parameter, defines how much energy is reflected from the load to the source of the RF systems. A reflection coefficient is also known as s_{11} parameter. By definition, a reflected coefficient is a ration of the reflected wave and the incident wave of the electric field strength. In the literature it is presented with the capital Greek letter gamma (Γ).

The mismatch of a load Z_L to a source Z_0 results in a reflection coefficient of:

$$\Gamma = (Z_L - Z_0) / (Z_L + Z_0)$$

Note that the load can be a complex (real and imaginary) impedance. If you can't remember in which order the numerator is subtracted (did we just say " $Z_L - Z_0$ " or " $Z_0 - Z_L$ "?), you can always figure it out by remembering that a short circuit ($Z_L = 0$) is on the left side of the [Smith chart](#) (angle = -180 degrees) which means $\Gamma = -1$ in this case, which means that the minus sign belongs in front of Z_0 .

The magnitude of the reflection coefficient is given by:

$$\rho = \text{mag}(\Gamma)$$

For cases where Z_L is a real number,

$$\rho = \text{abs}((Z_L - Z_0)/(Z_L + Z_0))$$

Note that "abs" means "absolute value" here. VSWR can be calculated from the magnitude of the reflection coefficient:

$$\text{VSWR} = (1 + \rho)/(1 - \rho)$$

For cases where Z_L is real, with a little algebra you'll see there are two cases for VSWR, calculated from load impedance:

$$\text{For } Z_L < Z_0: \text{VSWR} = Z_0/Z_L$$

$$\text{For } Z_L > Z_0: \text{VSWR} = Z_L/Z_0$$

VSWR:

VSWR is an abbreviation for Voltage Standing Wave Ratio or sometimes in literature just SWR (Standing Wave Ratio). The value of VSWR presents the power reflected from the load to the source. It is often used to describe how much power is lost from the source (usually a High Frequency Amplifier) through a transmission line (usually a coaxial cable) to the load (usually an antenna).

How to express VSWR using voltage?

By the definition, VSWR is the ratio of the highest voltage (the maximum amplitude of the standing wave) to the lowest voltage (the minimum amplitude of the standing wave) anywhere between source and load.

$$\text{VSWR} = |V(\text{max})| / |V(\text{min})|$$

$V(\text{max})$ = the maximum amplitude of the standing wave

$V(\text{min})$ = the minimum amplitude of the standing wave

What is the ideal value of a VSWR?

The value of an ideal VSWR is 1:1 or shortly expressed as 1. In this case the reflected power from the load to the source is zero.

How to express VSWR using an impedance?

By the definition, VSWR is the ratio of the load impedance and source impedance.

The reflection coefficient can also be expressed in terms of the characteristic impedance of the inner conductor and the matched load impedance as follows:

$$\Gamma = (Z_L - Z_0)/(Z_L + Z_0) \quad (\text{Eq. 5})$$

Where

Z_L is the matched load impedance.

Z_0 is the characteristic impedance of the inner conductor.

Substituting (Eq.5) into (Eq.2), to obtain VSWR in terms of Z_L and Z_0 :

$$VSWR = \frac{1 + \left| \frac{Z_L - Z_0}{Z_L + Z_0} \right|}{1 - \left| \frac{Z_L - Z_0}{Z_L + Z_0} \right|}$$

$$VSWR = \frac{[Z_L + Z_0 + |Z_L - Z_0|]}{[Z_L + Z_0 - |Z_L - Z_0|]} \quad (\text{Eq. 6})$$

Solving (Eq.6) for,

Case 1: if $Z_L > Z_0$ then $|Z_L - Z_0| = Z_L - Z_0$

$$\therefore VSWR = \frac{[Z_L + Z_0 + Z_L - Z_0]}{[Z_L + Z_0 - Z_L + Z_0]}$$

$$\therefore VSWR = \frac{Z_L}{Z_0} \quad (\text{Eq.7})$$

Case 2: if $Z_L < Z_0$ then $|Z_L - Z_0| = Z_0 - Z_L$

$$\therefore VSWR = \frac{[Z_L + Z_0 + Z_0 - Z_L]}{[Z_L + Z_0 - Z_0 + Z_L]}$$

$$\therefore VSWR = \frac{Z_0}{Z_L} \quad (\text{Eq. 8})$$

Z_L = the load impedance

Z_0 = the source impedance

How to express a VSWR using reflection and forward power?

By the definition VSWR is equal to

$$VSWR = 1 + \sqrt{(P_r/P_f)} / 1 - \sqrt{(P_r/P_f)}$$

where:

P_r = Reflected power

P_f = Forward power

Smith Chart:

The Smith Chart has been in use since the 1930s as a method to solve various RF design problems - notably impedance matching with series and shunt components - and it provides a convenient way to find these solutions without the use of a calculator. In order to understand the construction of the chart, you'll need to understand high school algebra and the basics of complex numbers, as well as have a basic understanding of impedance in electronic circuits. That said, even if you don't fully understand the derivation below, you can still use the chart to help you with your own design. By taking the standard reflection coefficient formula and manipulating it so that it provides us with the equations for circles of various radii, we'll be able to construct the basic Smith Chart. That's all the Smith Chart really is: a collection of circles, each one centered in a different place in (or outside) the plot, and each one representing either **constant resistance** or **constant reactance**

Deriving the Smith Chart

Once we get past the derivation, there will be a few simplified images showing how those equations can be used and combined to get the final product. Let's get started by writing the equation for the reflection coefficient of a load impedance, given a source impedance:

$$\Gamma = \frac{Z_{source} - Z_{load}}{Z_{source} + Z_{load}}$$

The reflection coefficient is just the ratio of the complex amplitude of a reflected wave to the amplitude of the incident wave. This is the main equation we'll be using, but there will be some quick transformations to it. First, we'll want to simplify it a little by normalizing the equation with respect to Z_{load} , dividing each term on the right side:

$$\Gamma = \frac{\frac{Z_{source}}{Z_{load}} - \frac{Z_{load}}{Z_{load}}}{\frac{Z_{source}}{Z_{load}} + \frac{Z_{load}}{Z_{load}}}$$

$$\Gamma = \frac{Z_O - 1}{Z_O + 1} \quad Z_O = \frac{Z_{source}}{Z_{load}}$$

At this point, recall that Z_O , being an impedance of complex value, can be represented in the form $R + jX$. Since the reflection coefficient (which is currently in polar form) can also be represented in rectangular coordinates (we'll use $A + jB$ for it), the above formula can be transformed into this:

$$A + jB = \frac{R + jX - 1}{R + jX + 1}$$

Great! At this point we've got the equation in the form we need to start constructing the Smith Chart. The next step - solving for the real and imaginary parts of the equation - is probably the most difficult part of the entire derivation, and even then you only need to understand the concept of complex conjugates to do it. Let's go ahead and split it into real and imaginary components, first by multiplying by the complex conjugate (it helps if you separate the existing real and imaginary parts using brackets as shown below):

$$A + jB = \frac{(R - 1) + jX}{(R + 1) + jX} \cdot \frac{(R + 1) - jX}{(R + 1) - jX}$$

$$A + jB = \frac{R^2 - 1 + X^2 + 2jX}{(R + 1)^2 + X^2}$$

At this point we can separate the real and imaginary components. After that, there will be two final simplifications to do before we'll have the equations to draw the Smith Chart. Here are the separated real and imaginary parts (we'll call them Equations 1 and 2):

$$A = \frac{R^2 - 1 + X^2}{(R + 1)^2 + X^2} \text{ (Equation 1)}$$

$$B = \frac{2X}{(R + 1)^2 + X^2} \text{ (Equation 2)}$$

Finally, you will want to do just a *little* more algebra (tedious, I know). Solving the real component, A, for X^2 , you will get Equation 3:

$$X^2 = \frac{A(R + 1)^2 - R^2 + 1}{1 - A} \text{ (Equation 3)}$$

You can substitute this into Equation 2 to get the first of our two final equations, which allows us to determine the circles of constant resistance (Equation 4):

$$\left(A - \frac{R}{R+1}\right)^2 + B^2 = \left(\frac{1}{R+1}\right)^2 \text{ (Equation 4)}$$

Does that look familiar? It's a circle, with a radius of $\frac{1}{R+1}$ and a center of $\left(\frac{R}{R+1}, 0\right)$. By varying the value of R in this equation, you can draw each of the circles in the Smith Chart.

Similarly, solving for R (I used Equation 2) will get you solutions that look like this:

$$R = \frac{\sqrt{-BX(BX-2)} - B}{B}$$

$$R = \frac{\sqrt{-BX(BX-2)} - B}{B}$$

which, when substituted and simplified into Equation 1, will get you this result (Equation 5):

$$(A-1)^2 + \left(B - \frac{1}{X}\right)^2 = \left(\frac{1}{X}\right)^2 \text{ (Equation 5)}$$

Just like the previous result, this is a circle with radius $1/X$ but this time there are two sets of circles (more on that in a bit), with centers at $(1, 1/X)$. These are circles (they appear as arcs on the diagram) of constant reactance. Now you should see how the standard Smith Chart is drawn; it consists of constant resistance circles graphed together with the constant reactance arcs. Below you'll find some simplified images of both equations graphed separately and combined. But first, let's talk about how to interpret the Smith Chart and its physical relevance.

There is quite a bit of information to obtain from analyzing the equations we've derived. Here are just a few things of note:

- At infinite R and X, both types of circles converge to the same location (typically shown on a Smith Chart at the far right or far left side of the diagram). This is at the point (1, 0).
- Setting $R = 0$ will result in a circle centered at (0, 0) on your chart with a radius of 1, which is the "boundary" of the chart.
- Approaching $X = 0$ results in an infinite radius; this is represented by a line crossing the center of the chart. How do we interpret this? This is often called the **real axis**. In terms of reactances, lines above the real axis in the chart (the positive arcs from the second derived equation) represent inductive reactances, while those below (negative arcs) represent capacitive reactances.

- What happens if $R < 0$? The standard Smith Chart doesn't provide much detail about this, but situations with R lying outside the boundary suggest oscillation in any would-be circuit (which is pretty handy to know).
- Based on the knowledge we now have on resistance and reactance on the chart, we know that every point represents a series combination of resistance and reactance ($R + jX$). This'll help us when we want to do some plotting

Constant Resistance Circles:

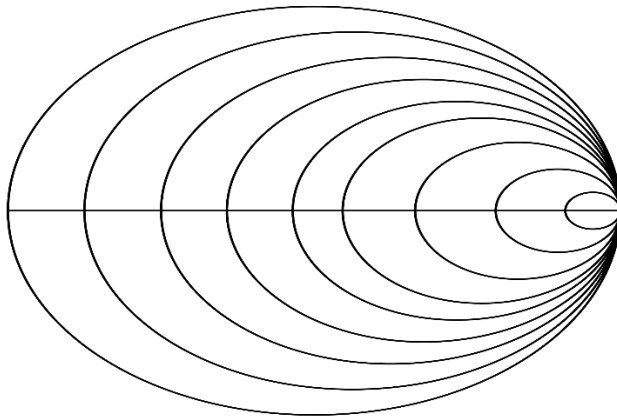

Constant Reactance Arcs:

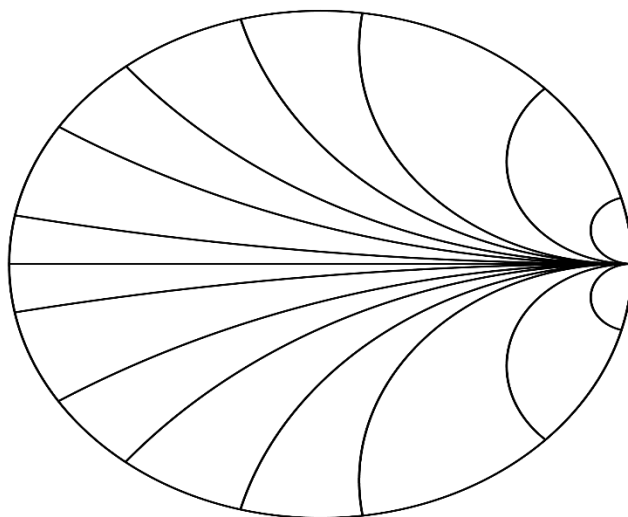

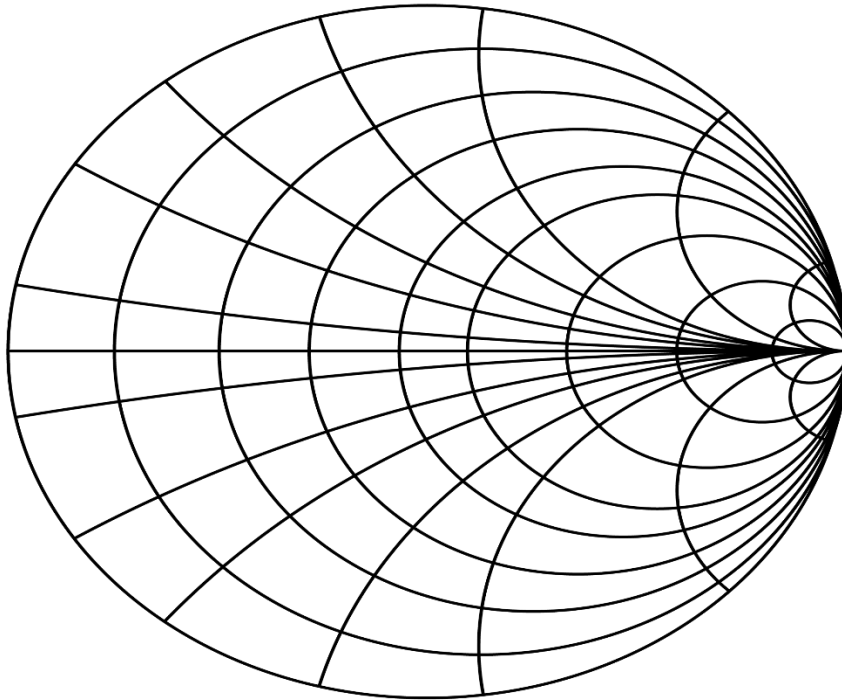
Smith Chart:

Constant resistance and reactance circles plotted together

Applications of Smith Charts:

Smith charts find applications in all areas of RF Engineering. Some of the most popular application includes;

- **Impedance calculations** on any transmission line, on any load.
- **Admittance calculations** on any transmission line, on any load.
- Calculation of the length of a short-circuited piece of transmission line to provide a required capacitive or inductive reactance.
- **Impedance matching.**
- Determining VSWR among others.