

MALLA REDDY COLLEGE OF ENGINEERING & TECHNOLOGY

(Autonomous Institution – UGC, Govt. of India)

Recognized under 2(f) and 12 (B) of UGC ACT 1956

(Affiliated to JNTUH, Hyderabad, Approved by AICTE - Accredited by NBA & NAAC –
'A' Grade - ISO 9001:2015 Certified)

Maisammaguda, Dhulapally (Post Via. Kompally), Secunderabad – 500100, Telangana
State, India



DEPARTMENT OF ELECTRICAL & ELECTRONICS ENGINEERING

DIGITAL NOTES for ELECTRICAL MACHINES-III

For

B.Tech (EEE) – III YEAR – I SEMESTER

Prepared by

Mr. GUNTIPALLY SEKHAR BABU

Assistant Professor, EEE



MALLA REDDY COLLEGE OF ENGINEERING AND TECHNOLOGY

III B.Tech EEE I Sem

L T/P/D C

3 1 / - / - 3

(R18A0204)ELECTRICAL MACHINES – III

OBJECTIVES:

This subject is an extension of previous machines courses. It deals with the detailed analysis of Synchronous generators and motors which are the prime source of electrical power generation and its utilities. Also concerns about the different types of single phase motors which are having significant applications in house hold appliances and control systems.

UNIT - I:

Synchronous Machine & Characteristics: Constructional Features of round rotor and salient pole machines – Armature windings – Integral slot and fractional slot windings; Distributed and concentrated windings – distribution, pitch and winding factors – E.M.F Equation. Armature reaction - leakage reactance – synchronous reactance and impedance – experimental determination - phasor diagram – load characteristics.

UNIT - II:

Regulation of Synchronous Generator: Regulation by synchronous impedance method, M.M.F. method, Z.P.F. method and A.S.A. methods – salient pole alternators – two reaction analysis – experimental determination of X_d and X_q (Slip test) Phasor diagrams – Regulation of salient pole alternators.

UNIT - III:

Parallel Operation of Synchronous Generator: Synchronizing alternators with infinite bus bars – synchronizing power torque – parallel operation and load sharing - Effect of change of excitation and mechanical power input.

UNIT - IV:

Synchronous Motors: Theory of operation – phasor diagram – Variation of current and power factor with excitation – synchronous condenser – Mathematical analysis for power developed. Hunting and its suppression – Methods of starting – synchronous induction motor.

UNIT - V:

Single Phase Motors & Special Machines: Single phase Motors: Single phase induction motor – Constructional features-Double revolving field theory Equivalent circuit - split-phase motors - Capacitor start Capacitor run motors. Principles of A.C. Series motor-Universal motor, Stepper motor, shaded pole motor (Qualitative Treatment only).

TEXT BOOKS:

1. Electrical Machines – by P.S. Bimbhra, Khanna Publishers.
2. Electrical Machines(Ac & Dc machines), by J B GUPTA, S K kataria and sons
3. Electric Machines, I. J. Nagrath & D. P. Kothari, Tata Mc Graw Hill Publishers.

REFERENCE BOOKS:

1. Electro mechanics - III (Synchronous and single phase machines), S. Kamakashiah, Right Publishers.
2. Performance and Design of AC Machines, MG. Say, BPB Publishers.

3. Theory of Alternating Current Machinery, Langsdorf, Tata McGraw-Hill Companies.
4. Electric machinery, A.E. Fitzgerald, C. Kingsley and S. Umans, Mc Graw Hill Companies.

OUTCOMES:

After going through this course the student gets a thorough knowledge on,

1. construction and operation characteristics of synchronous machines.
2. Regulation methods of synchronous generator
3. parallel-operation of synchronous generator & starting methods of synchronous motors
4. speed control methods of synchronous motors and
5. operating characteristics of single-phase motors and special machines, with which he/she can able to apply the above conceptual things to real-world electrical and problems and applications.

UNIT-I

SYNCHRONOUS MACHINES & CHARACTERISTICS

Introduction

Synchronous machines are principally used as alternating current generators. They supply the electric power used by all sectors of modern society. Synchronous machine is an important electromechanical energy converter. Synchronous generators usually operate in parallel forming a large power system supplying electrical power to consumers or loads. For these applications the synchronous generators are built in large units, their rating ranging from tens to hundreds of Megawatts. These synchronous machines can also be run as synchronous motors.

Synchronous machines are AC machines that have a field circuit supplied by an external DC source. Synchronous machines are having two major parts namely stationary part stator and a rotating field system called rotor.

In a synchronous generator, a DC current is applied to the rotor winding producing a rotor magnetic field. The rotor is then driven by external means producing a rotating magnetic field, which induces a 3-phase voltage within the stator winding.

Field windings are the windings producing the main magnetic field (rotor windings for synchronous machines); armature windings are the windings where the main voltage is induced (stator windings for synchronous machines).

Types of synchronous machines

According to the arrangement of armature and field winding, the synchronous machines are classified as rotating armature type or rotating field type.

In rotating armature type the armature winding is on the rotor and the field winding is on the stator. The generated emf or current is brought to the load via the slip rings. These type of generators are built only in small units.

In case of rotating field type generators field windings are on the rotor and the armature windings are on the stator. Here the field current is supplied through a pair of slip rings and the induced emf or current is supplied to the load via the stationary terminals.

Based on the type of the prime movers employed the synchronous generators are classified as

1. Hydrogenerators : The generators which are driven by hydraulic turbines are called hydrogenerators. These are run at lower speeds less than 1000 rpm.
2. Turbogenerators: These are the generators driven by steam turbines. These generators are run at very high speed of 1500rpm or above.
3. Engine driven Generators: These are driven by IC engines. These are run at aspeed less than 1500 rpm.

Construction of synchronous machines

1. Salient pole Machines: These type of machines have salient pole or projecting poles with concentrated field windings. This type of construction is for the machines which are driven by hydraulic turbines or Diesel engines.
2. Nonsalient pole or Cylindrical rotor or Round rotor Machines: These machines are having cylindrical smooth rotor construction with distributed field winding in slots. This type of rotor construction is employed for the machine driven by steam turbines.

Stator core:

The stator is the outer stationary part of the machine, which consists of

- The outer cylindrical frame called yoke, which is made either of welded sheet steel, cast iron.

- The magnetic path, which comprises a set of slotted steel laminations called stator core pressed into the cylindrical space inside the outer frame. The magnetic path is laminated to reduce eddy currents, reducing losses and heating. CRGO laminations of 0.5 mm thickness are used to reduce the iron losses.

A set of insulated electrical windings are placed inside the slots of the laminated stator. The cross-sectional area of these windings must be large enough for the power rating of the machine. For a 3-phase generator, 3 sets of windings are required, one for each phase connected in star. Fig. 1 shows one stator lamination of a synchronous generator. In case of generators where the diameter is too large stator lamination can not be punched in on circular piece. In such cases the laminations are punched in segments. A number of segments are assembled together to form one circular laminations. All the laminations are insulated from each other by a thin layer of varnish.

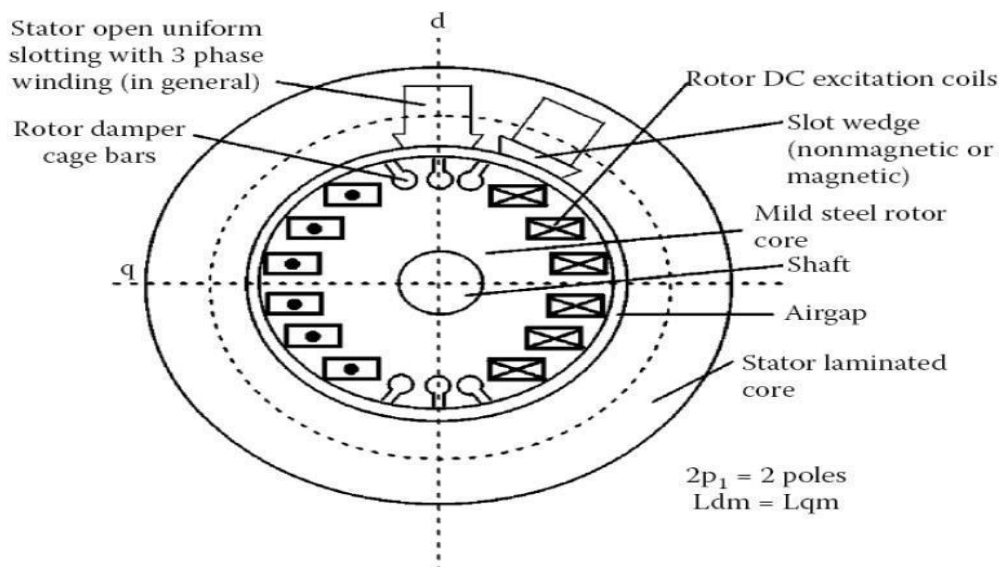

Figure 1.1. Non Salient pole generator

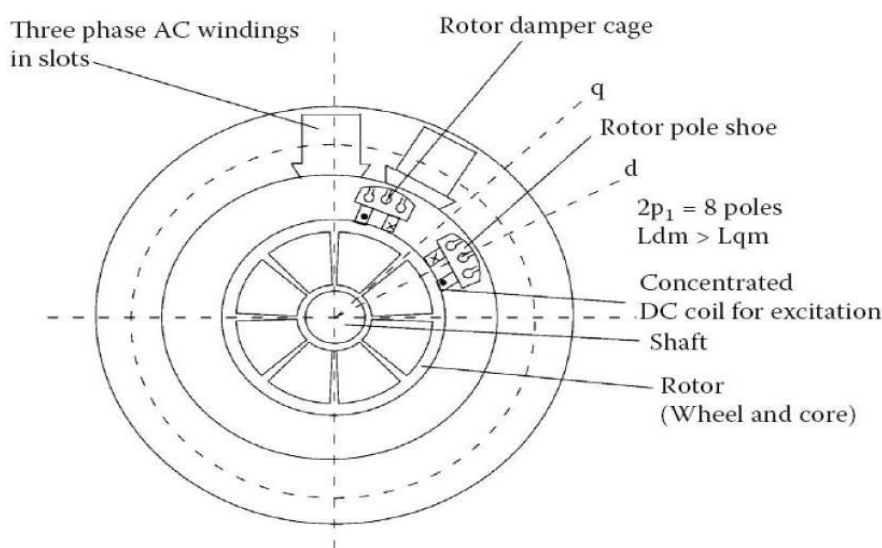

Figure: 1.2. Salient pole generator.

Rotor of water wheel generator consists of salient poles. Poles are built with thin silicon steel laminations of 0.5mm to 0.8 mm thickness to reduce eddy current laminations. The laminations are clamped by heavy end plates and secured by studs or rivets. For low speed rotors poles have the bolted on construction for the machines with little higher peripheral

speed poles have dove tailed construction as shown in Figs. Generally rectangular or round pole constructions are used for such type of alternators. However the round poles have the advantages over rectangular poles.

Generators driven by water wheel turbines are of either horizontal or vertical shaft type. Generators with fairly higher speeds are built with horizontal shaft and the generators with higher power ratings and low speeds are built with vertical shaft design. Vertical shaft generators are of two types of designs (i) Umbrella type where in the bearing is mounted below the rotor. (ii) Suspended type where in the bearing is mounted above the rotor.

In case of turbo alternator the rotors are manufactured from solid steel forging. The rotor is slotted to accommodate the field winding. Normally two third of the rotor periphery is slotted to accommodate the winding and the remaining one third unslotted portion acts as the pole. Rectangular slots with tapering teeth are milled in the rotor. Generally rectangular aluminum or copper strips are employed for field windings. The field windings and the overhangs of the field windings are secured in place by steel retaining rings to protect against high centrifugal forces. Hard composition insulation materials are used in the slots which can withstand high forces, stresses and temperatures. Perfect balancing of the rotor is done for such type of rotors.

Damper windings are provided in the pole faces of salient pole alternators. Damper windings are nothing but the copper or aluminium bars housed in the slots of the pole faces. The ends of the damper bars are short circuited at the ends by short circuiting rings similar to end rings as in the case of squirrel cage rotors. These damper windings are serving the function of providing mechanical balance; provide damping effect, reduce the effect of over voltages and damp out hunting in case of alternators. In case of synchronous motors they act as rotor bars and help in self starting of the motor.

Relation between Speed and Frequency:

In the previous course on induction motors it is established that the relation between speed and frequency and number of poles is given by

$$\text{Frequency } f = P \times N / 120 \text{ Hz}$$

Windings in Alternators: In case of three phase alternators the following types of windings are employed.

- (i) Lap winding,
- (ii) wave winding and
- (iii) Mush winding. Based on pitch of the coil
 - (i) full pitched
 - (ii) short pitched
- windings Based on number of layers
 - (i) Single layer
 - (ii) Double layer

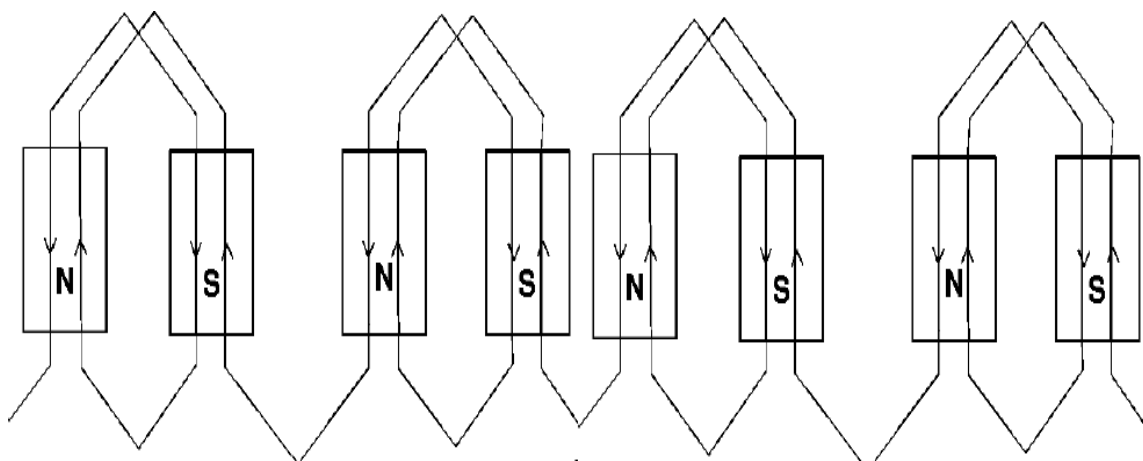

Figure: 1.3. Single layer winding

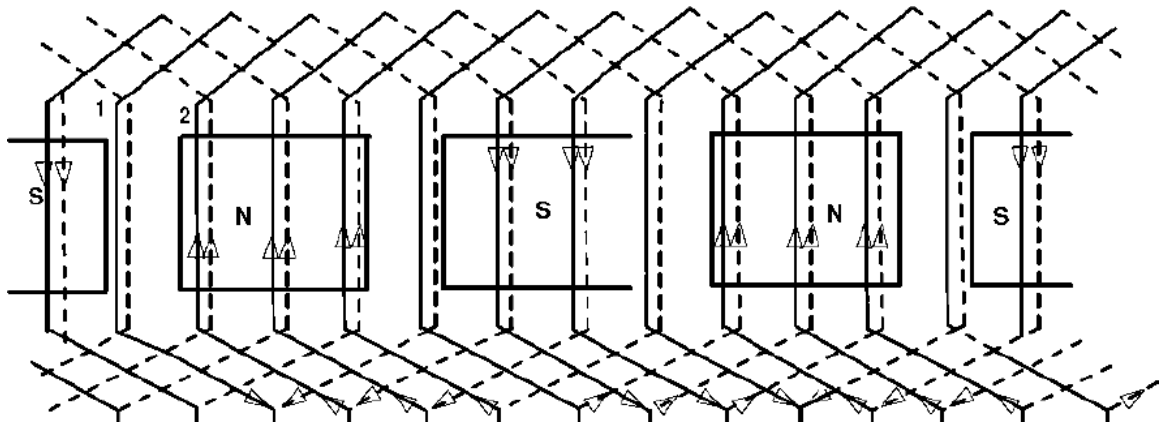

Figure: 1.4. Double layer winding

EMF Equation of an alternator:

Consider the following

Φ = flux per pole in wb

P = Number of poles

N_s = Synchronous speed in rpm

f = frequency of induced emf in Hz

Z = total number of conductors

Z_{ph} = conductors per phase connected in series

T_{ph} = Number of turns per phase

Assuming concentrated winding, considering one conductor placed in a slot According to Faradays Law electromagnetic induction,

The average value of emf induced per conductor in one revolution

$e_{avg} = d/dt$ e_{avg} = Change of Flux in one revolution/ Time taken for one revolution

Change of Flux in one revolution = $p \Phi$

Time taken for one revolution = $60/N_s$ seconds

Hence $e_{avg} = (p \Phi) / (60/N_s)$

= $p \Phi \times N_s / 60$ We know $f = PN_s / 120$

hence $PN_s / 60 = 2f$

Hence $e_{avg} = 2 f \Phi$ volts

Hence average emf per turn = $2 \times 2 f \Phi$ volts = $4 f \Phi$ volts

If there are T_{ph} , number of turns per phase connected in series, then average emf induced in T_{ph} turns is $E_{ph, avg} = T_{ph} \times e_{avg} = 4 f \Phi T_{ph}$ volts

Hence RMS value of emf induced $E = 1.11 \times E_{ph, avg}$

$$= 1.11 \times 4 f \Phi T_{ph} \text{ volts}$$

$$= 4.44 f \Phi T_{ph} \text{ volts}$$

This is the general emf equation for the machine having concentrated and full pitched winding.

In practice, alternators will have short pitched winding and hence coil span will not be 180° , but on or two slots short than the full pitch.

Pitch Factor:

Pitch factor $K_p = \text{emf induced in a short pitched coil} / \text{emf induced in a full pitched coil} = (2E \cos \alpha/2) / 2E$

$$K_p = \cos \alpha/2$$

where α is called chording angle.

Distribution Factor: Even though we assumed concentrated winding in deriving emf equation, in practice an attempt is made to distribute the winding in all the slots coming under a pole. Such a winding is called distributed winding.

In concentrated winding the emf induced in all the coil sides will be same in magnitude and in phase with each other. In case of distributed winding the magnitude of emf will be same but the emfs induced in each coil side will not be in phase with each other as they are distributed in the slots under a pole. Hence the total emf will not be same as that in concentrated winding but will be equal to the vector sum of the emfs induced. Hence it will be less than that in the concentrated winding. Now the factor by which the emf induced in a distributed winding gets reduced is called distribution factor and defined as the ratio of emf induced in a distributed winding to emf induced in a concentrated winding.

Distribution factor $K_d = \text{emf induced in a distributed winding} / \text{emf induced in a concentrated winding} = \text{vector sum of the emf} / \text{arithmetic sum of the emf}$

Let

$E = \text{emf induced per coil side,}$

$m = \text{number of slots per pole per phase}$

$n = \text{number of slots per pole}$

$\beta = \text{slot angle} = 180/n$

The emf induced in concentrated winding with m slots per pole per phase = mE volts.

Fig below shows the method of calculating the vector sum of the voltages in a distributed winding having a mutual phase difference of β . When m is large curve ACEN will form the arc of a circle of radius r .

From the figure below $AC = 2 \times r \times$

$\sin \beta/2$ Hence arithmetic sum = $m \times$

$2r \sin \beta/2$

Now the vector sum of the emfs is AN as shown in figure below = $2 \times r \times \sin m\beta/2$

Hence the distribution factor $K_d = \text{vector sum of the emf} / \text{arithmetic sum of the emf}$

$$= (2r \sin m\beta/2) / (m \times 2r \sin \beta/2)$$

$$K_d = (\sin m\beta/2) / (m \sin \beta/2)$$

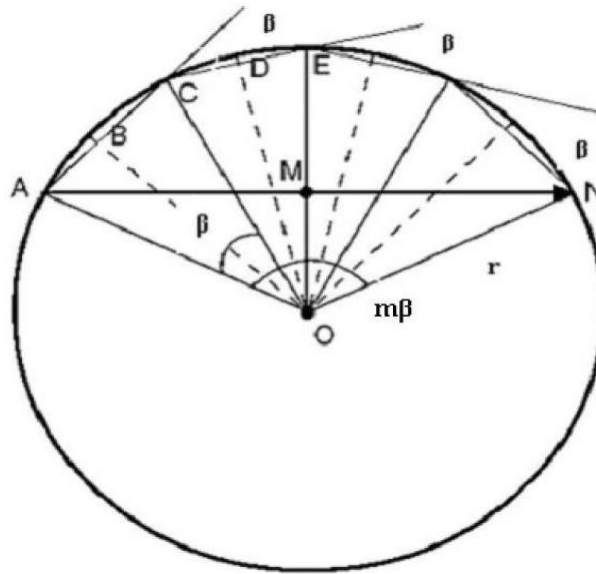

Figure: 1.5. Calculation of vector sum

In practical machines the windings will be generally short pitched and distributed over the periphery of the machine. Hence in deducing the emf equation both pitch factor and distribution factor has to be considered. Hence the general emf equation including pitch factor and distribution factor can be given as

$$\text{EMF induced per phase} = 4.44 f T_{ph} \times K_p K_d \text{ volts}$$

$$E_{ph} = 4.44 K_p K_d f T_{ph} \text{ volts}$$

$$\text{Hence the line Voltage } E_L = \sqrt{3} \times \text{phase voltage} = \sqrt{3} E_{ph}$$

Effect of Harmonics of pitch and distribution Factor:

The pitch factor is given by $K_p = \cos \alpha/2$, where α is the chording angle.

For any harmonic say n^{th} harmonic the pitch factor is given by $K_{pn} = \cos n\alpha/2$

The distribution factor is given by $K_d = (\sin m\beta/2) / (m \sin \beta/2)$

For any harmonic say n^{th} harmonic the distribution factor is given by $K_{dn} = (\sin m n\beta/2) / (m \sin n\beta/2)$

Operation of Alternators:

Similar to the case of DC generator, the behavior of a Synchronous generator connected to an external load is different than that at no-load. In order to understand the performance of the Synchronous generator when it is loaded, consider the flux distributions in the machine when the armature also carries a current. Unlike in the DC machine in alternators the emf peak and the current peak will not occur in the same coil due to the effect of the power factor of the load. The current and the induced emf will be at their peaks in the same coil only for upf loads. For zero power factor lagging loads, the current reaches its peak in a coil which falls behind that coil wherein the induced emf is at its peak by 90 electrical degrees or half a pole-pitch. Likewise for zero power factor leading loads, the current reaches its peak in a coil which is ahead of that coil wherein the induced emf is at its peak by 90 electrical degrees or half a pole-pitch. For simplicity, assume the resistance and leakage reactance of the stator windings to be negligible. Also assume the magnetic circuit to be linear i.e. the flux in the magnetic circuit is deemed to be proportional to the resultant ampere-turns - in other words

the machine is operating in the linear portion of the magnetization characteristics. Thus the emf induced is the same as the terminal voltage, and the phase-angle between current and emf is determined only by the power factor (pf) of the external load connected to the synchronous generator.

Armature Reaction: Magnetic fluxes in alternators

There are three main fluxes associated with an alternator:

- (i) Main useful flux linked with both field & armature winding.
- (ii) Leakage flux linked only with armature winding.
- (iii) Leakage flux linked only with field winding.

The useful flux which links with both windings is due to combined mmf of the armature winding and field winding. When the armature winding of an alternator carries current then an mmf sets in armature. This armature mmf reacts with field mmf producing the resultant flux, which differs from flux of field winding alone. The effect of armature reaction depends on nature of load (power factor of load). At no load condition, the armature has no reaction due to absence of armature flux. When armature delivers current at unity power factor load, then the resultant flux is displaced along the air gap towards the trailing pole tip. Under this condition, armature reaction has distorting effect on mmf wave as shown in Figure. At zero lagging power factor loads the armature current is lagging by 90° with armature voltage. Under this condition, the position of armature conductor when inducing maximum emf is the centre line of field mmf. Since there is no distortion but the two mmf are in opposition, the armature reaction is now purely demagnetizing as shown in Figure. Now at zero power factors leading, the armature current leads armature voltage by 90° . Under this condition, the mmf of armature as well as the field winding is in same phase and additive. The armature mmf has magnetizing effect due to leading armature current as shown in Figure.

(a) Unity Power Factor

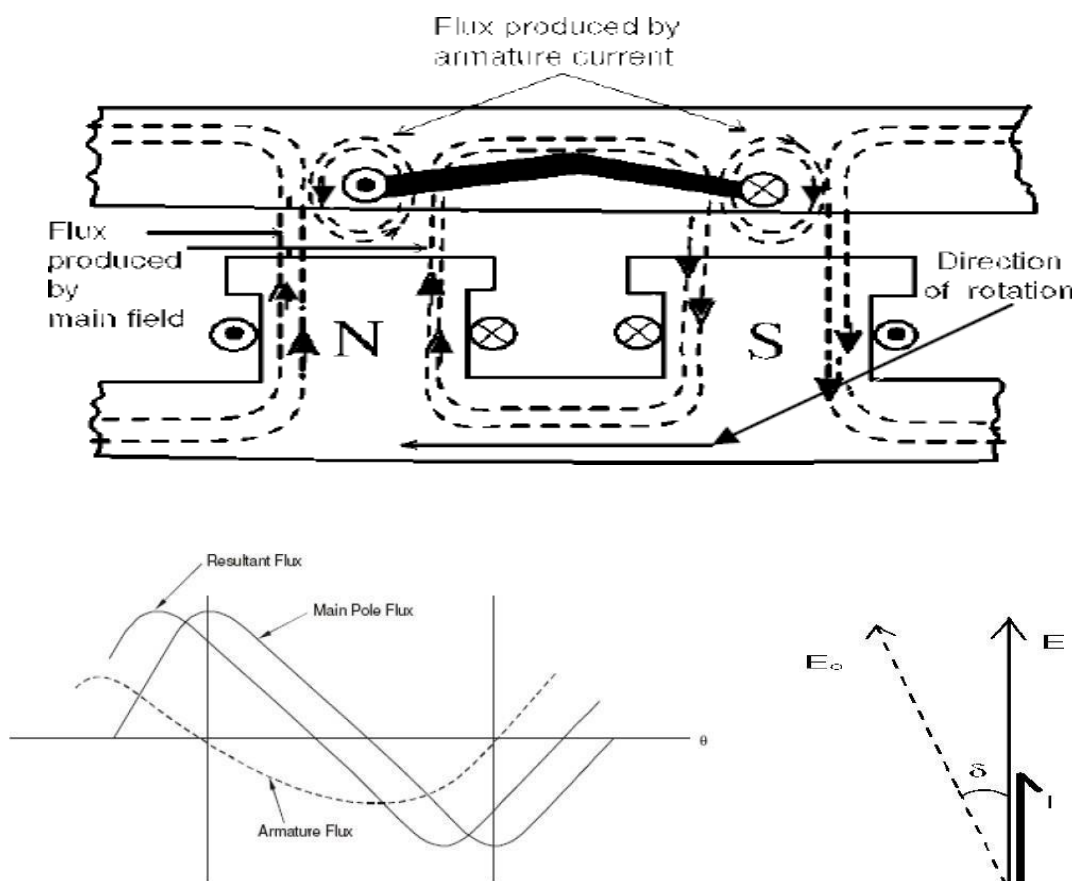

Figure: 1.6. Distorting effect of armature reaction

(b) Zero Power Factor Lagging

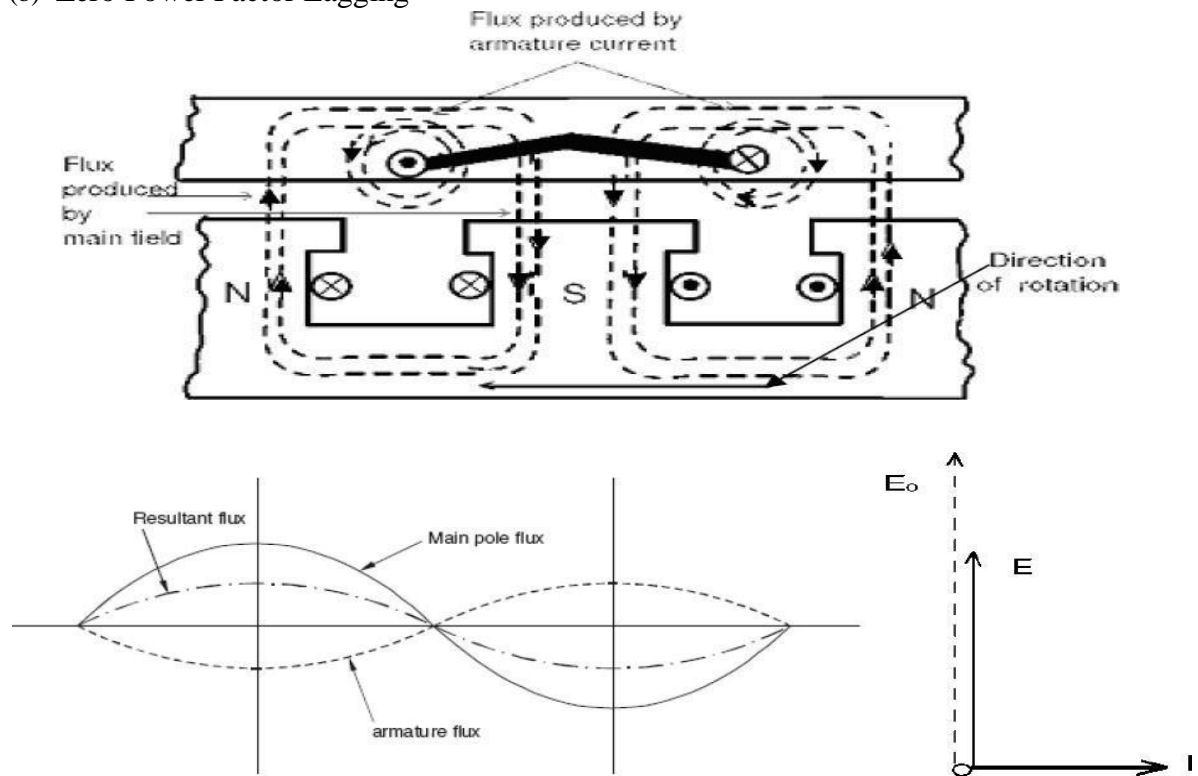

Figure1.7. Demagnetizing effect of armature reaction

(c) Zero Power Factor Leading

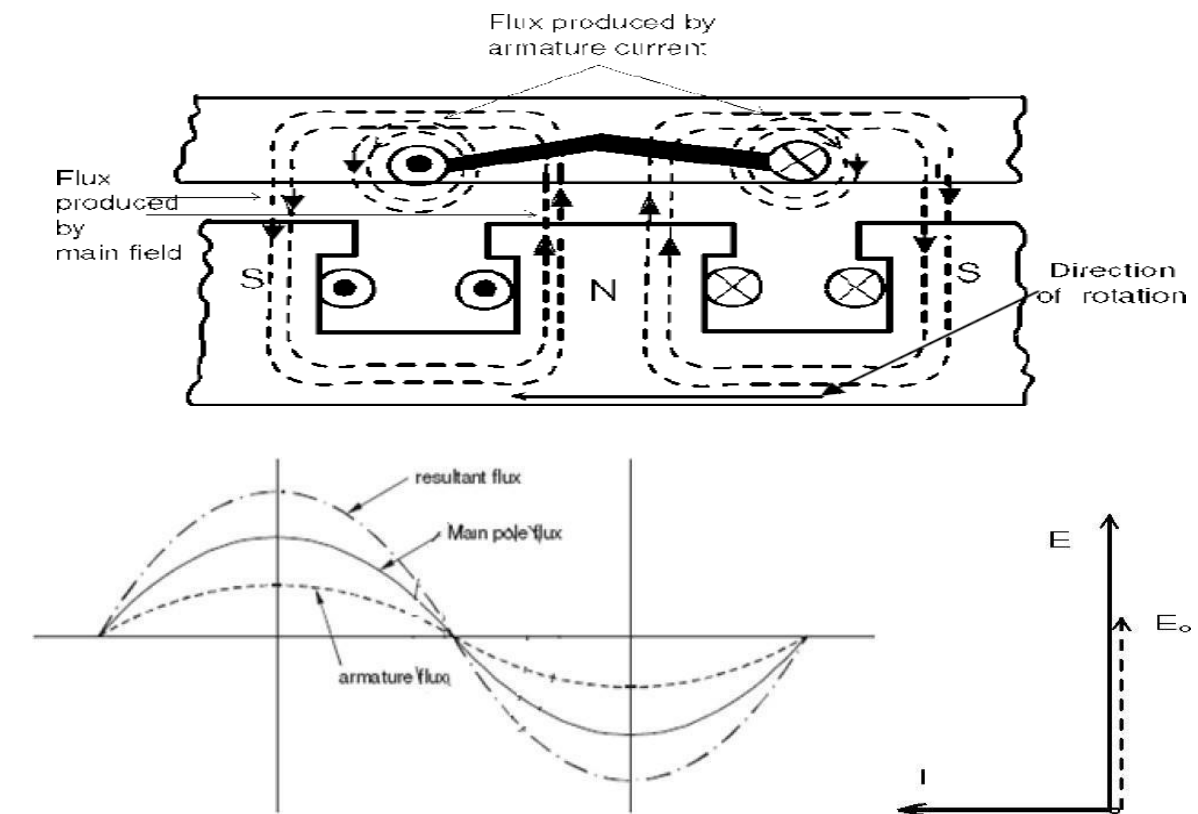

Figure1.8. Magnetizing effect of armature reaction

When the rotor is run, a voltage E is induced in the stator windings. If a load is connected to the terminals of the generator, a current flows. The 3-phase stator current flow will produce a magnetic field of its own. This stator magnetic field will distort the original rotor magnetic field, changing the resulting phase voltage. This effect is called armature reaction because the armature (stator) current affects the magnetic field.

From the phasor diagrams of the armature reaction it can be seen that E_0 is the emf induced under no load condition and E can be considered as the emf under loaded condition. It can also be understood that the E_0 is the emf induced due to the field winding acting alone and E is the emf induced when both field winding and stator winding are acting in combination. Hence emf E can be considered as sum of E_0 and another fictitious emf E_a proportional to the stator current. From the figures it can be seen that the emf E_a is always in quadrature with current. This resembles the emf induced in an inductive reactance. Hence the effect of armature reaction is exactly same as if the stator has an additional reactance $x_a = E_a/I$. This is called the armature reaction reactance. The leakage reactance is the true reactance and the armature reaction reactance is a fictitious reactance.

Synchronous Reactance and Synchronous Impedance

The synchronous reactance is an equivalent reactance the effects of which are supposed to reproduce the combined effects of both the armature leakage reactance and the armature reaction. The alternator is supposed to have no armature reaction at all, but is supposed to possess an armature reactance in excess of its true leakage reactance. When the synchronous reactance is combined vectorially with the armature resistance, a quantity called the synchronous impedance is obtained as shown in figure.

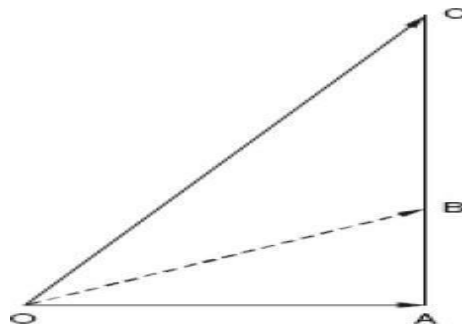

- OA = Armature Resistance
- AB = Leakage Reactance
- BC = Equivalent Reactance of Armature Reaction
- AC = Synchronous Reactance
- OC = Synchronous Impedance

The armature winding has one more reactance called armature reaction reactance in addition to leakage reactance and resistance. Considering all the three parameters the equivalent circuit of a synchronous generator can be written as shown below. The sum of leakage reactance and armature reaction reactance is called synchronous reactance X_s . Under this condition impedance of the armature winding is called the synchronous impedance Z_s .

Hence synchronous reactance $X_s = X_l + X_a$ per phase
and synchronous impedance $Z_s = R_a + j X_s$ per phase

As the armature reaction reactance is dependent on armature current so is synchronous reactance and hence synchronous impedance is dependent on armature current or load current.

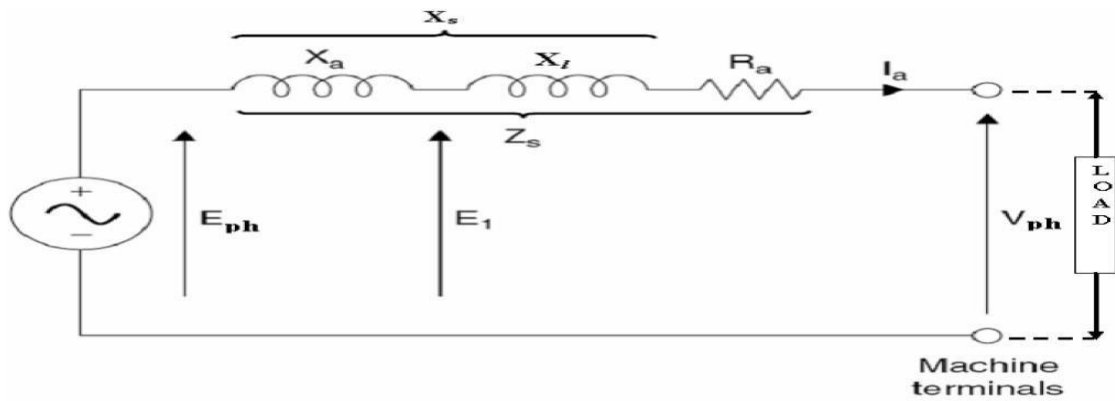

Figure: 1.9. Equivalent circuit of alternator

Phasor diagram

In the phasor diagrams E is the induced emf /phase = E_{ph} and V is the terminal voltage /phase = V_{ph} . From each of the phasor diagrams the expression for the induced emf E_{ph} can be expressed in terms of V_{ph} , armature current, resistance, reactances and impedance of the machine as follows.

- (i) Unity power factor load

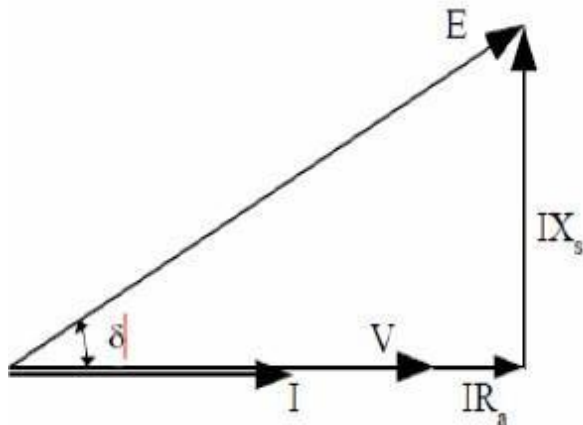

Figure: 1.10. Phasor diagram at Unity power factor load

Under unity power factor load: $E_{ph} = (V + IR_a) + j (IX_s)$

$$E_{ph} = \sqrt{[(V + IR_a)^2 + (IX_s)^2]}$$

- (ii) Zero power factor lagging

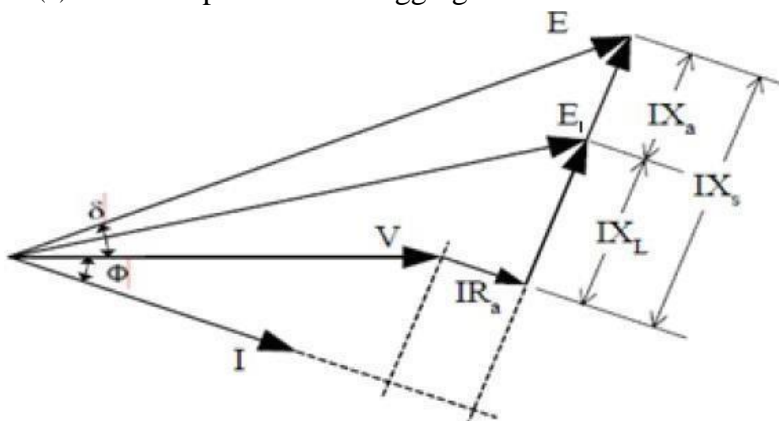

Figure: 1.11. Phasor diagram at zero power factor lagging

Under zero power factor lagging: $E_{ph} = V + (IR_a + j IX_s) = V + I(R_a + j X_s)$

The above expression can also be written as $E_{ph} = \sqrt{[(V \cos \phi + IR_a)^2 + (V \sin \phi + IX_s)^2]}$

(iii) Zero power factor leading

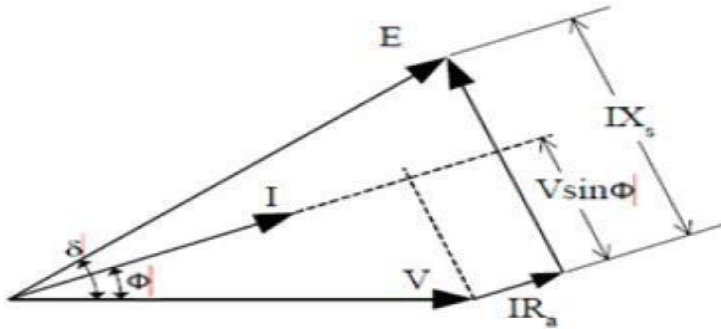

Figure: 1.12. Phasor diagram at zero power factor leading.

UNIT-II

REGULATION OF SYNCHRONOUS GENERATOR

Voltage Regulation

When an alternator is subjected to a varying load, the voltage at the armature terminals varies to a certain extent, and the amount of this variation determines the regulation of the machine. When the alternator is loaded the terminal voltage decreases as the drops in the machine starts increasing and hence it will always be different than the induced emf.

Voltage regulation of an alternator is defined as the change in terminal voltage from no load to full load expressed as a percentage of rated voltage when the load at a given power factor is removed with out change in speed and excitation. Or The numerical value of the regulation is defined as the percentage rise in voltage when full load at the specified power-factor is switched off with speed and field current remaining unchanged expressed as a percentage of rated voltage.

Hence regulation can be expressed as

$$\% \text{ Regulation} = (E_{ph} - V_{ph} / V_{ph}) \times 100$$

where E_{ph} = induced emf /phase, V_{ph} = rated terminal voltage/phase

Methods of finding Voltage Regulation: The voltage regulation of an alternator can be determined by different methods. In case of small generators it can be determined by direct loading whereas in case of large generators it cannot determined by direct loading but will be usually predetermined by different methods. Following are the different methods used for predetermination of regulation of alternators.

1. Direct loading method
2. EMF method or Synchronous impedance method
3. MMF method or Ampere turns method
4. ASA modified MMF method
5. ZPF method or Potier triangle method

All the above methods other than direct loading are valid for non salient pole machines only. As the alternators are manufactured in large capacity direct loading of alternators is not employed for determination of regulation. Other methods can be employed for predetermination of regulation. Hence the other methods of determination of regulations will be discussed in the following sections.

EMF method: This method is also known as synchronous impedance method. Here the magnetic circuit is assumed to be unsaturated. In this method the MMFs (fluxes) produced by rotor and stator are replaced by their equivalent emf, and hence called emf method.

To predetermine the regulation by this method the following informations are to be determined. Armature resistance /phase of the alternator, open circuit and short circuit characteristics of the alternator.

OC & SC test on alternator

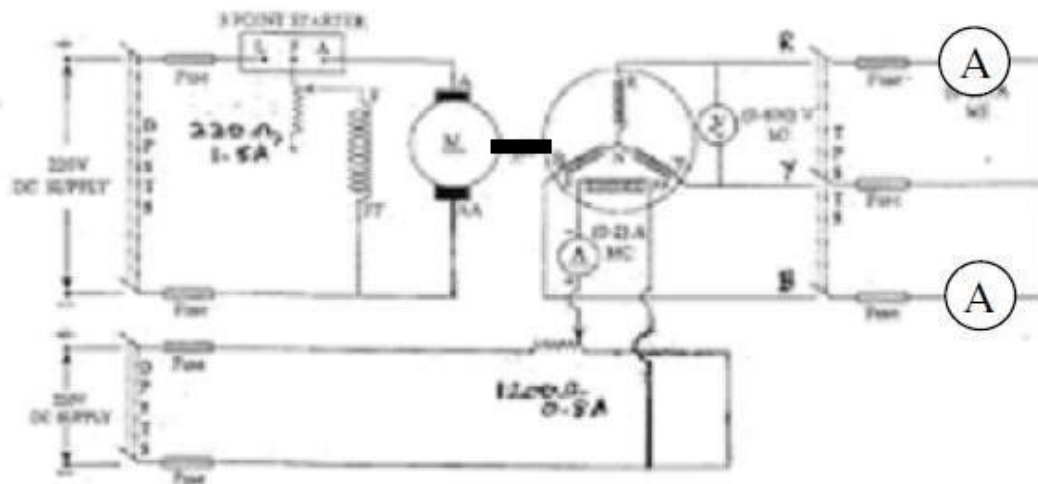

Figure: 2.1. OC & SC test on alternator

Open Circuit Characteristic (O.C.C.)

The open-circuit characteristic or magnetization curve is really the B-H curve of the complete magnetic circuit of the alternator. Indeed, in large turbo-alternators, where the air gap is relatively long, the curve shows a gradual bend. It is determined by inserting resistance in the field circuit and measuring corresponding value of terminal voltage and field current. Two voltmeters are connected across the armature terminals. The machine is run at rated speed and field current is increased gradually to I_{f1} till armature voltage reaches rated value or even 25% more than the rated voltage. Figure 32 illustrates a typical circuit for OC and SC test and figure 33 illustrates OC and SC curve. The major portion of the exciting ampere-turns is required to force the flux across the air gap, the reluctance of which is assumed to be constant. A straight line called the air gap line can therefore be drawn as shown, dividing the excitation for any voltage into two portions, (a) that required to force the flux across the air gap, and (b) that required to force it through the remainder of the magnetic circuit. The shorter the air gap, the steeper is the air gap line.

Procedure to conduct OC test:

- (i) Start the prime mover and adjust the speed to the synchronous speed of the alternator.
- (ii) Keep the field circuit rheostat in cut in position and switch on DC supply.
- (iii) Keep the TPST switch of the stator circuit in open position.
- (iv) Vary the field current from minimum in steps and take the readings of field current and stator terminal voltage, till the voltage read by the voltmeter reaches up to 110% of rated voltage. Reduce the field current and stop the machine.
- (v) Plot of terminal voltage/ phase vs field current gives the OC curve.

Short Circuit Characteristic (S.C.C.)

The short-circuit characteristic, as its name implies, refers to the behaviour of the alternator when its armature is short-circuited. In a single-phase machine the armature terminals are short-circuited through an ammeter, but in a three-phase machine all three phases must be short-circuited. An ammeter is connected in series with each armature terminal, the three

remaining ammeter terminals being short-circuited. The machine is run at rated speed and field current is increased gradually to I_{f2} till armature current reaches rated value. The armature short-circuit current and the field current are found to be proportional to each other over a wide range, as shown in Figure 33, so that the short-circuit characteristic is a straight line. Under short-circuit conditions the armature current is almost 90° out of phase with the voltage, and the armature mmf has a direct demagnetizing action on the field. The resultant ampere – turns inducing the armature emf are, therefore, very small and is equal to the difference between the field and the armature ampere – turns. This results in low mmf in the magnetic circuit, which remains in unsaturated condition and hence the small value of induced emf increases linearly with field current. This small induced armature emf is equal to the voltage drop in the winding itself, since the terminal voltage is zero by assumption. It is the voltage required to circulate the short-circuit current through the armature windings. The armature resistance is usually small compared with the reactance.

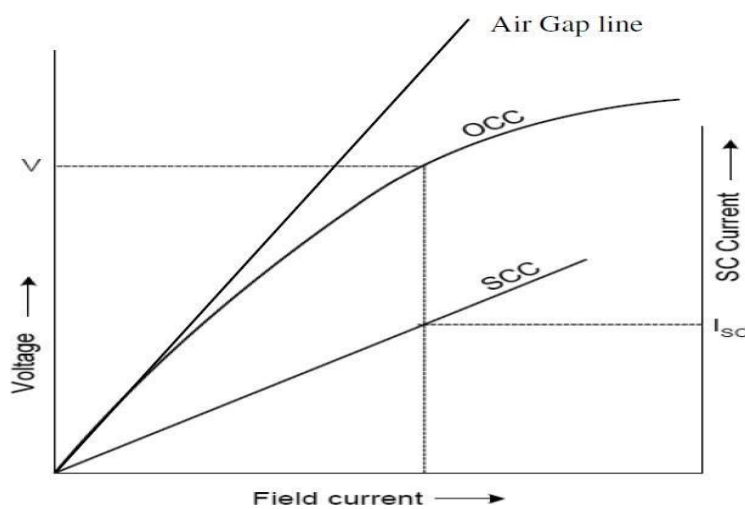

Figure: 2.2 OCC & SCC of an alternator

Short-Circuit Ratio:

The short-circuit ratio is defined as the ratio of the field current required to produce rated volts on open circuit to field current required to circulate full-load current with the armature short-circuited.

$$\text{Short-circuit ratio} = I_{f1}/I_{f2}$$

Determination of synchronous impedance Z_s :

As the terminals of the stator are short circuited in SC test, the short circuit current is circulated against the impedance of the stator called the synchronous impedance. This impedance can be estimated from the oc and sc characteristics.

The ratio of open circuit voltage to the short circuit current at a particular field current, or at a field current responsible for circulating the rated current is called the synchronous impedance.

$$\text{synchronous impedance } Z_s = (\text{open circuit voltage per phase})/(\text{short circuit current per phase}) \text{ for same } I_f$$

Hence $Z_s = (V_{oc}) / (I_{sc})$ for same I_f

From figure 33 synchronous impedance $Z_s = V/I_{sc}$

Armature resistance R_a of the stator can be measured using Voltmeter – Ammeter method.

Using synchronous impedance and armature resistance synchronous reactance and hence regulation can be calculated as follows using emf method.

$$Z_s = \sqrt{(R_a)^2 + (X_s)^2}$$

$$\text{and Synchronous reactance } X_s = \sqrt{(Z_s)^2 - (R_a)^2}$$

Hence induced emf per phase can be found as

$$E_{ph} = \sqrt{[(V \cos \phi + IR_a)^2 + (V \sin \phi \pm IX_s)^2]}$$

where V = phase voltage per phase = V_{ph} , I = load current per phase

in the above expression in second term + sign is for lagging power factor and – sign is for leading power factor.

$$\% \text{ Regulation} = [(E_{ph} - V_{ph} / V_{ph})] \times 100$$

where E_{ph} = induced emf /phase, V_{ph} = rated terminal voltage/phase

Synchronous impedance method is easy but it gives approximate results. This method gives the value of regulation which is greater (poor) than the actual value and hence this method is called pessimistic method. The complete phasor diagram for the emf method is shown in figure

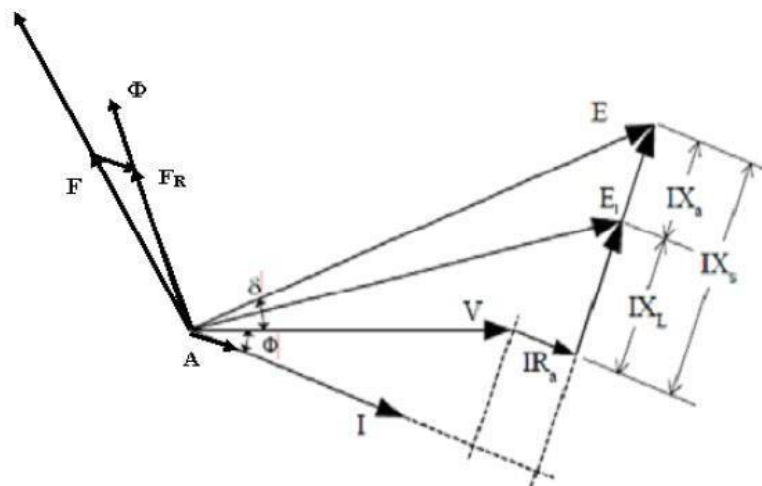

Figure: 2.3. Phasor diagram of alternator.

MMF method:

This method is also known as amp - turns method. In this method the all the emfs produced by rotor and stator are replaced by their equivalent MMFs (fluxes), and hence called mmf method. In this method also it is assumed that the magnetic circuit is unsaturated. In this method both the reactance drops are replaced by their equivalent mmfs. Figure 35 shows the complete phasor diagram for the mmf method. Similar to emf method OC and SC characteristics are used for the determination of regulation by mmf method. The details are shown in figure . Using the details it is possible determine the regulation at different power factors.

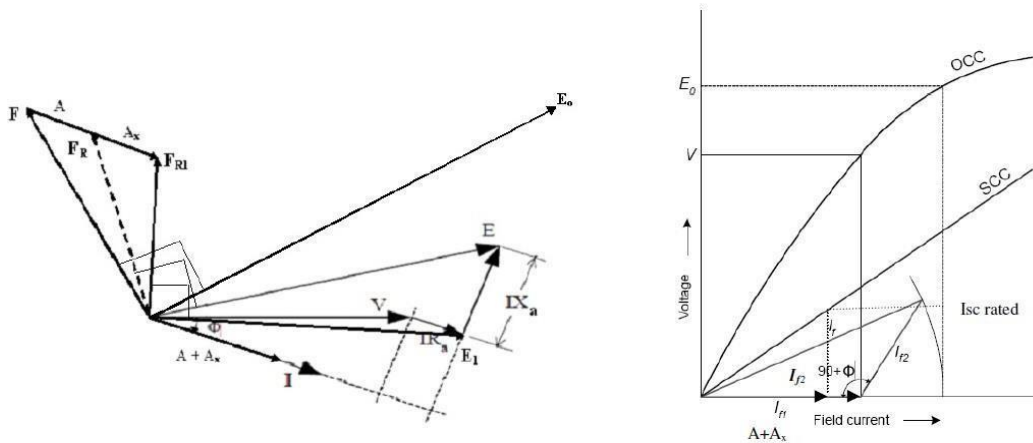

Figure: 2.4. Phasor diagram for MMF method and characteristics.

From the phasor diagram it can be seen that the mmf required to produce the emf $E_1 = (V + IR_a)$ is FR_1 . In large machines resistance drop may be neglected.

The mmf required to overcome the reactance drops is $(A + A_x)$ as shown in phasor diagram. The mmf $(A + A_x)$ can be found from SC characteristic as under SC condition both reactance drops will be present.

Following procedure can be used for determination of regulation by mmf method.

- (i) By conducting OC and SC test plot OCC and SCC as shown in figure 36.
- (ii) From the OCC find the field current I_{f1} required to produce the voltage, $E_1 = (V + IR_a)$.
- (iii) From SCC find the magnitude of field current $I_{f2} (\approx A + A_x)$ to produce the required armature current. $A + A_x$ can also be found from ZPF characteristics.
- (iv) Draw I_{f2} at angle $(90 + \Phi)$ from I_{f1} , where Φ is the phase angle of current w. r. t voltage. If current is leading, take the angle of I_{f2} as $(90 - \Phi)$ as shown in figure 36.
- (v) Determine the resultant field current, I_f and mark its magnitude on the field current axis.
- (vi) From OCC. find the voltage corresponding to I_f , which will be E_0 and hence find the Regulation.

Because of the assumption of unsaturated magnetic circuit the regulation computed by this method will be less than the actual and hence this method of regulation is called optimistic method.

ASA Modified MMF Method

Because of the unrealistic assumption of unsaturated magnetic circuit neither the emf method nor the mmf method are giving the realistic value of regulation. In spite of these shortcomings these methods are being used because of their simplicity. Hence ASA has modified mmf method for calculation of regulation. With reference to the phasor diagram of mmf method it can be seen that $F = FR_1 - (A + A_x)$. In the mmf method the total mmf F computed is based on the assumption of unsaturated magnetic circuit which is unrealistic. In order to account for the partial saturation of the magnetic circuit it must be increased by a certain amount FF_2 which can be computed from occ, scc and air gap lines as explained below referring to figure

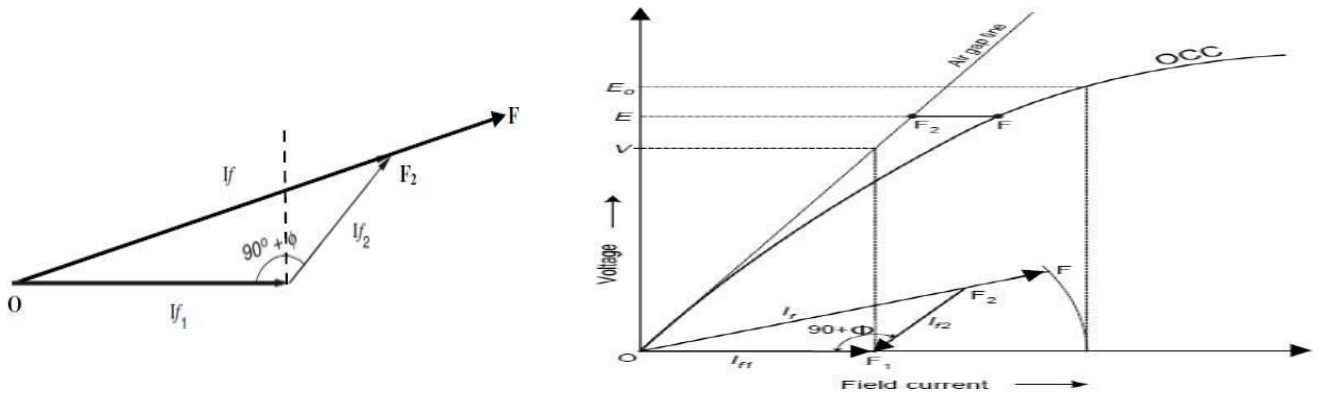

Figure: 2.5. Phasor diagram for ASA method and characteristics

I_{f1} is the field current required to induce the rated voltage on open circuit. Draw I_{f2} with length equal to field current required to circulate rated current during short circuit condition at an angle $(90+\Phi)$ from I_{f1} . The resultant of I_{f1} and I_{f2} gives I_f (OF2 in figure). Extend OF2 upto F so that F2F accounts for the additional field current required for accounting the effect of partial saturation of magnetic circuit. F2F is found for voltage E (refer to phasor diagram of mmf method) as shown in figure 41. Project total field current OF to the field current axis and find corresponding voltage E_0 using OCC. Hence regulation can be found by ASA method which is more realistic.

Zero Power Factor (ZPF) method Potier Triangle Method

During the operation of the alternator, resistance voltage drop $I_a R_a$ and armature leakage reactance drop $I_a X_L$ are actually emf quantities and the armature reaction reactance is a mmf quantity. To determine the regulation of the alternator by this method OCC, SCC and ZPF test details and characteristics are required. As explained earlier oc and sc tests are conducted and OCC and SCC are drawn. ZPF test is conducted by connecting the alternator to ZPF load and exciting the alternator in such way that the alternator supplies the rated current at rated voltage running at rated speed. To plot ZPF characteristics only two points are required. One point is corresponding to the zero voltage and rated current that can be obtained from scc and the other at rated voltage and rated current under zpf load. This zero power factor curve appears like OCC but shifted by a factor IX_L vertically and horizontally by armature reaction mmf as shown below in figure. Following are the steps to draw ZPF characteristics.

By suitable tests plot OCC and SCC. Draw air gap line. Conduct ZPF test at full load for rated voltage and fix the point B. Draw the line BH with length equal to field current required to produce full load current on short circuit. Draw HD parallel to the air gap line so as to cut the OCC. Draw DE perpendicular to HB or parallel to voltage axis. Now, DE represents voltage drop IX_L and BE represents the field current required to overcome the effect of armature reaction.

Triangle BDE is called Potier triangle and X_L is the Potier reactance. Find E from V , $I R_a$, IX_L and Φ . Use the expression $E = \sqrt{(V \cos\Phi + I R_a)^2 + (V \sin\Phi + IX_L)^2}$ to compute E. Find field current corresponding to E. Draw FG with magnitude equal to BE at angle $(90+\Psi)$ from field current axis, where Ψ is the phase angle of current from voltage vector E (internal phase angle).

The resultant field current is given by OG. Mark this length on field current axis. From OCC find the corresponding E_0 . Find the regulation.

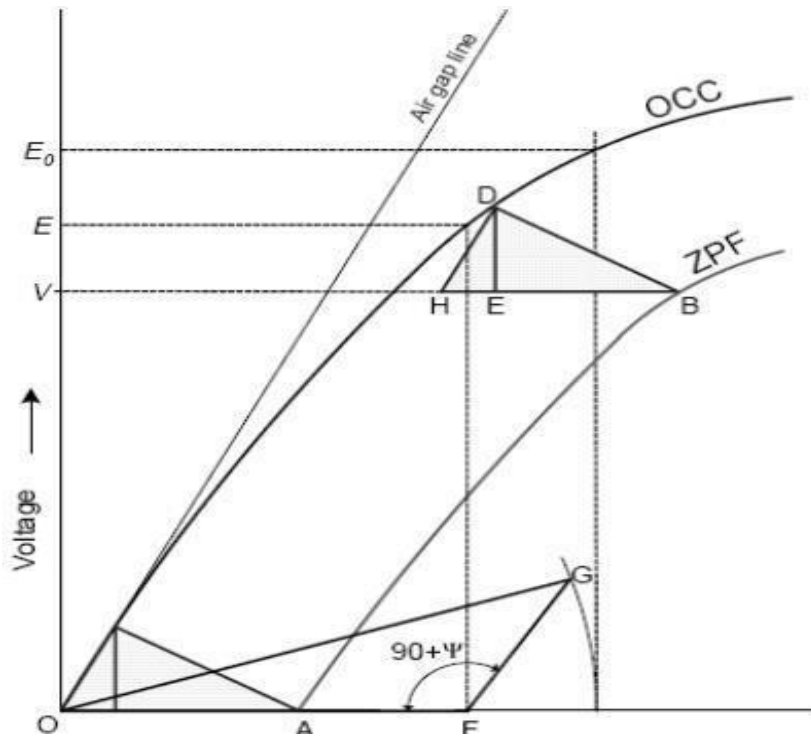

Figure: 2.6 ZPF method characteristics

Salient pole alternators and Blondel's Two reaction Theory

The details of synchronous generators developed so far is applicable to only round rotor or non salient pole alternators. In such machines the air gap is uniform throughout and hence the effect of mmf will be same whether it acts along the pole axis or the inter polar axis. Hence reactance of the stator is same throughout and hence it is called synchronous reactance. But in case salient pole machines the air gap is non uniform and it is smaller along pole axis and is larger along the inter polar axis. These axes are called direct axis or d-axis and quadrature axis or q-axis. Hence the effect of mmf when acting along direct axis will be different than that when it is acting along quadrature axis. Hence the reactance of the stator cannot be same when the mmf is acting along d – axis and q- axis. As the length of the air gap is small along direct axis reluctance of the magnetic circuit is less and the air gap along the q – axis is larger and hence the along the quadrature axis will be comparatively higher. Hence along d-axis more flux is produced than q-axis. Therefore the reactance due to armature reaction will be different along d-axis and q-axis. These reactances are

X_{ad} = direct axis reactance; X_{aq} = quadrature axis reactance

Hence the effect of armature reaction in the case of a salient pole synchronous machine can be taken as two components - one acting along the direct axis (coinciding with the main field pole axis) and the other acting along the quadrature axis (inter-polar region or magnetic neutral axis) - and as such the mmf components of armature-reaction in a salient-pole machine cannot be considered as acting on the same magnetic circuit. Hence the effect of the armature reaction cannot be taken into account by considering only the synchronous reactance, in the case of a salient pole synchronous machine.

In fact, the direct-axis component F_{ad} acts over a magnetic circuit identical with that of the main field system and produces a comparable effect while the quadrature-axis component

F_{aq} acts along the inter polar axis, resulting in an altogether smaller effect and, in addition, a flux distribution totally different from that of F_{ad} or the main field m.m.f. This explains why the application of cylindrical-rotor theory to salient-pole machines for predicting the performance gives results not conforming to the performance obtained from an actual test.

Blondel's two-reaction theory considers the effects of the quadrature and direct-axis components of the armature reaction separately. Neglecting saturation, their different effects are considered by assigning to each an appropriate value of armature-reaction "reactance," respectively x_{ad} and x_{aq} . The effects of armature resistance and true leakage reactance (X_L) may be treated separately, or may be added to the armature reaction coefficients on the assumption that they are the same, for either the direct-axis or quadrature-axis components of the armature current (which is almost true). Thus the combined reactance values can be expressed as : $X_{sd} = x_{ad} + x_l$ and $X_{sq} = x_{aq} + x_l$ for the direct- and cross-reaction axes respectively.

In a salient-pole machine, x_{aq} , the quadrature-axis reactance is smaller than x_{ad} , the direct-axis reactance, since the flux produced by a given current component in that axis is smaller as the reluctance of the magnetic path consists mostly of the interpolar spaces. It is essential to clearly note the difference between the quadrature and direct-axis components I_{aq} , and I_{ad} of the armature current I_a , and the reactive and active components I_{aa} and I_{ar} . Although both pairs are represented by phasors in phase quadrature, the former are related to the induced emf E_t while the latter are referred to the terminal voltage V . These phasors are clearly indicated with reference to the phasor diagram of a (salient pole) synchronous generator supplying a lagging power factor (pf) load, shown in Fig

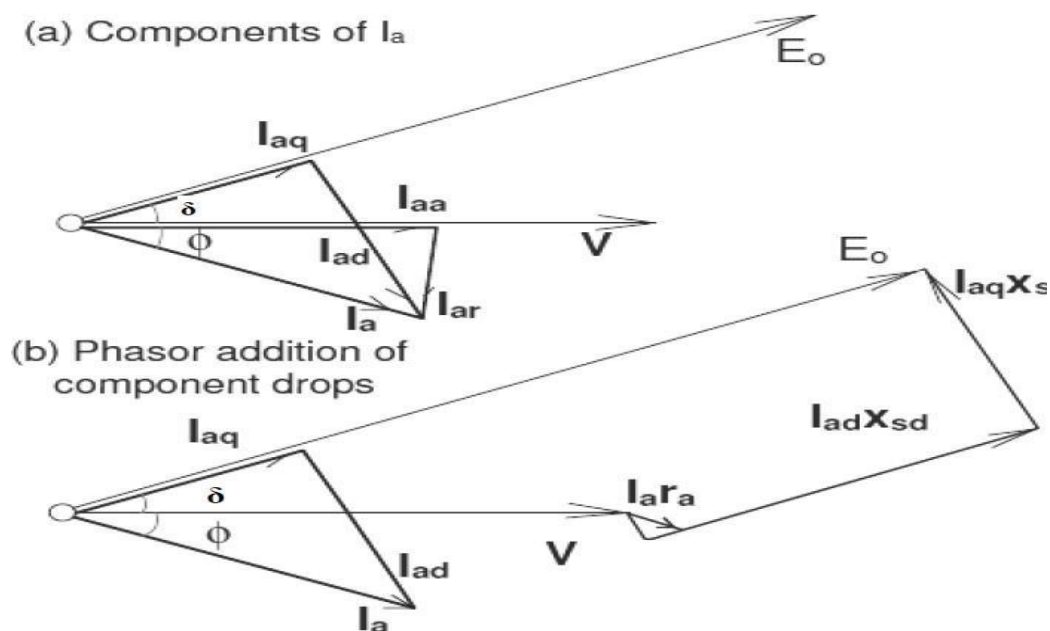

Figure: 2.7. Phasor diagram of salient pole alternator

$$I_{aq} = I_a \cos(\delta + \phi); I_{ad} = I_a \sin(\delta + \phi); \text{ and } I_a = \sqrt{[I_{aq}]^2 + [I_{ad}]^2}$$

$$I_{aa} = I_a \cos \phi; I_{ar} = I_a \sin \phi; \text{ and } I_a = \sqrt{[I_{aa}]^2 + [I_{ar}]^2}$$

where δ = torque or power angle and ϕ = the p.f. angle of the load.

The phasor diagram shows the two reactance voltage components $I_{aq} * X_{sq}$ and $I_{ad} * X_{sd}$ which are in quadrature with their respective components of the armature current. The resistance drop $I_a \times R_a$ is added in phase with I_a although we could take it as $I_{aq} \times R_a$ and $I_{ad} \times R_a$ separately, which is unnecessary as $I_a = I_{ad} + jI_{aq}$.

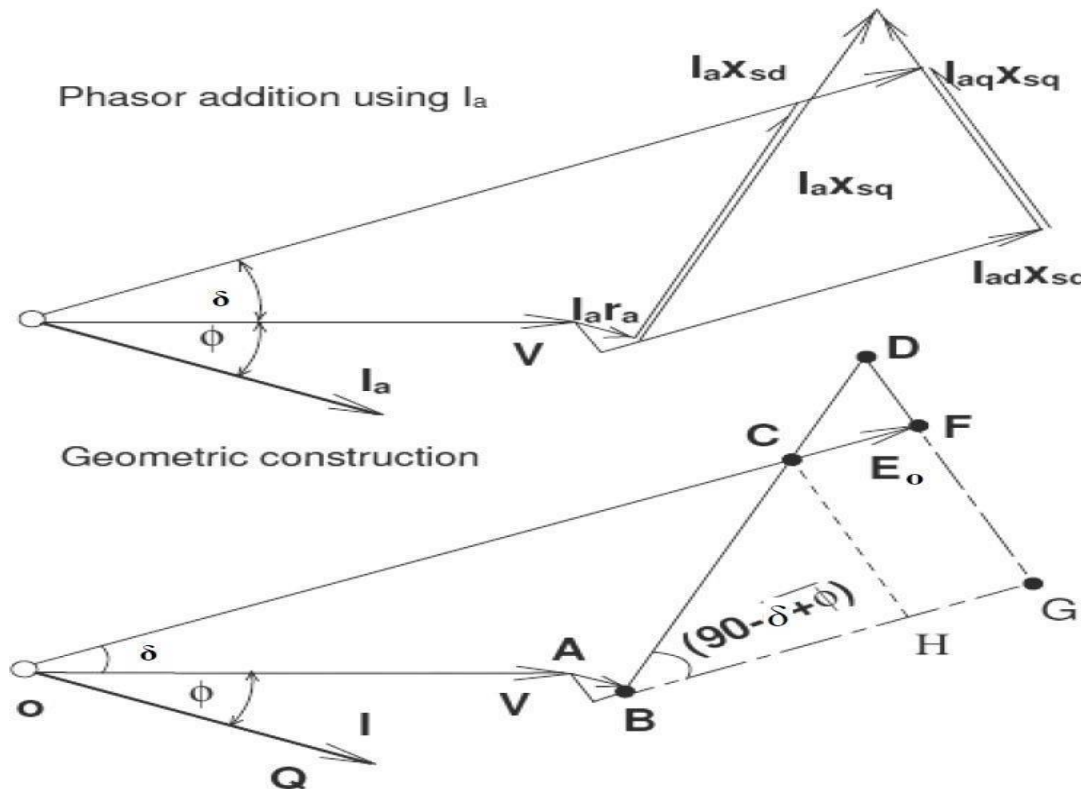

Figure: 2.8. Phasor diagram of salient pole alternator.

Power output of a Salient Pole Synchronous Machine

Neglecting the armature winding resistance, the power output of the generator is given by: $P = V \times I_a \times \cos \phi$

This can be expressed in terms of δ , by

noting that $I_a \cos \phi = I_{aq} \cos \delta + I_{ad} \sin \delta$

$V \cos \delta = E_0 - I_{ad} * X_{sd}$ and $V \sin \delta = I_{aq} * X_{sq}$

Substituting the above expressions for power we get

$$P = V [(V \sin \delta / X_{sd}) * \cos \delta + (E_0 - V \cos \delta) / X_{sd} * \sin \delta]$$

On simplification we get

$$P = (V * E_0 / X_{sd}) \sin \delta + V^2 * (X_{sd} - X_{sq}) / (2 * X_{sq} * X_{sq}) * \sin 2 \delta$$

The above expression for power can also be written as

$$P = (E_0 * V * \sin \delta / X_d) + V^2 * (X_d - X_q) * \sin 2 \delta / (2 * X_q * X_q)$$

The above expression for power consists of two terms first is called electromagnetic power and the second is called reluctance power.

It is clear from the above expression that the power is a little more than that for a cylindrical rotor synchronous machine, as the first term alone represents the power for a cylindrical rotor synchronous machine. A term in $(\sin 2\delta)$ is added into the power – angle characteristic of a non-salient pole synchronous machine. This also shows that it is possible to generate an emf even if the excitation E_0 is zero. However this magnitude is quite less compared with that obtained with a finite E_0 . Likewise it can be shown that the machine develops a torque - called the reluctance torque - as this torque is developed due to the variation of the reluctance in the magnetic circuit even if the excitation E_0 is zero.

Determination of X_d and X_q by slip test:

The direct and quadrature axis reactances X_d and X_q of a synchronous machine can be experimentally determined by a simple test known as slip test. Basic circuit diagram for conducting this test is shown in figure. Here the armature terminals are supplied with a subnormal voltage of rated frequency with field circuit left open. The generator is driven by a prime mover at a slip speed which is slightly more or less than the synchronous speed. This is equivalent to the condition in which the armature mmf remains stationary and rotor rotates at a slip speed with respect to the armature mmf. As the rotor poles slip through the armature mmf the armature mmf will be in line with direct axis and quadrature axis alternately. When it is in line with the direct axis the armature mmf directly acts on the magnetic circuit and at this instant the voltage applied divided by armature current gives the direct axis synchronous reactance. When the armature mmf coincides with the quadrature axis then the voltage impressed divided by armature current gives the quadrature axis synchronous reactance. Since $X_d > X_q$ the pointers of the ammeter reading the armature current will oscillate from a minimum to a maximum. Similarly the terminal voltage will also oscillate between the minimum and maximum.

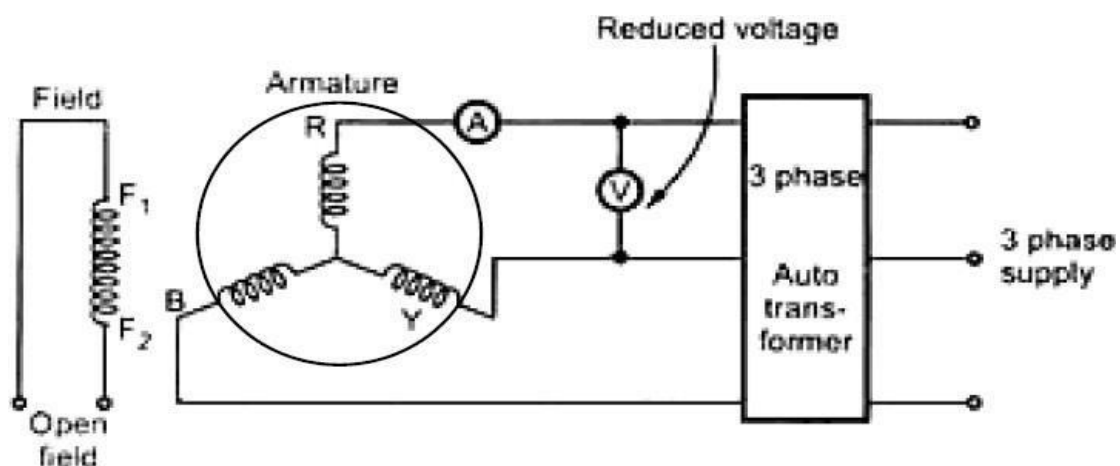

Figure: 2.9. Slip test

- ∴ $X_d = \text{Maximum voltage} / \text{minimum current}$
 $X_q = \text{Minimum voltage} / \text{maximum current.}$

UNIT-III
PARALLEL OPERATION OF SYNCHRONOUS
GENERATORS

Synchronizing of alternators:

Synchronizing

The operation of connecting two alternators in parallel is known as synchronizing. Certain conditions must be fulfilled before this can be effected. The incoming machine must have its voltage and frequency equal to that of the bus bars and, should be in same phase with bus bar voltage. The instruments or apparatus for determining when these conditions are fulfilled are called synchrosopes. Synchronizing can be done with the help of (i) dark lamp method or (ii) by using synchroscope.

Reasons for operating in parallel:

- a) Handling larger loads.
- b) Maintenance can be done without power disruption.
- c) Increasing system reliability.
- d) Increased efficiency.

Conditions required for

Paralleling:

The figure below shows a synchronous generator G1 supplying power to a load, with another generator G2 about to be paralleled with G1 by closing switch S1. What conditions must be met before the switch can be closed and the 2 generators connected in parallel?

Paralleling 2 or more generators must be done carefully as to avoid generator or other system component damage. Conditions to be satisfied are as follows:

- a) RMS line voltages must be equal.
- b) The generators to be paralleled must have the same phase sequence.
- c) The oncoming generator (the new generator) must have the same operating frequency as compared to the system frequency.

General Procedure for Paralleling Generators:

Consider the figure shown below. Suppose that generator G2 is to be connected to the running system as shown below:

1. Using Voltmeters, the field current of the oncoming generator should be adjusted until its terminal voltage is equal to the line voltage of the running system.
2. Check and verify phase sequence to be identical to the system phase sequence. There are 2 methods to do this:
 - i. One way is using the 3 lamp method, where the lamps are stretched across the open terminals of the switch connecting the generator to the system (as shown in the figure below). As the phase changes between the 2 systems, the lamps first get bright (large phase difference) and then get dim (small phase difference). If all 3 lamps get bright and dark together, then the systems have the same phase sequence. If the lamps brighten in succession, then the systems have the opposite phase sequence, and one of the sequences must be reversed.

- ii. Using a Synchroscope – a meter that measures the difference in phase angles (it does not check phase sequences only phase angles).
3. Check and verify generator frequency is same as that of the system frequency. This is done by watching a frequency of brightening and dimming of the lamps until the frequencies are close by making them to change very slowly.
4. Once the frequencies are nearly equal, the voltages in the 2 systems will change phase with respect to each other very slowly. The phase changes are observed, and when the phase angles are equal, the switch connecting the 2 systems is closed.

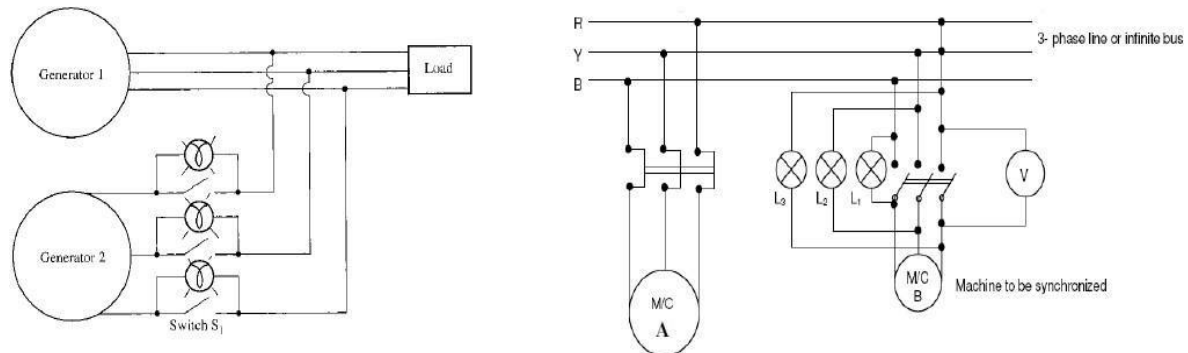

Figure: 3.1. Synchronization of alternators.

Synchronizing Current

If two alternators generating exactly the same emf are perfectly synchronized, there is no resultant emf acting on the local circuit consisting of their two armatures connected in parallel. No current circulates between the two and no power is transferred from one to the other. Under this condition emf of alternator 1, i.e. E_1 is equal to and in phase opposition to emf of alternator 2, i.e. E_2 as shown in the Figure. There is, apparently, no force tending to keep them in synchronism, but as soon as the conditions are disturbed a synchronizing force is developed, tending to keep the whole system stable. Suppose one alternator falls behind a little in phase by an angle θ .

The two alternator emfs now produce a resultant voltage and this acts on the local circuit consisting of the two armature windings and the joining connections. In alternators, the synchronous reactance is large compared with the resistance, so that the resultant circulating current I_s is very nearly in quadrature with the resultant emf E_r acting on the circuit. Figure represents a single phase case, where E_1 and E_2 represent the two induced emfs, the latter having fallen back slightly in phase. The resultant emf, E_r , is almost in quadrature with both the emfs, and gives rise to a current, I_s , lagging behind E_r by an angle approximating to a right angle. It is, thus, seen that E_1 and I_s are almost in phase. The first alternator is generating a power $E_1 I_s \cos \Phi_1$, which is positive, while the second one is generating a power $E_2 I_s \cos \Phi_2$, which is negative, since $\cos \Phi_2$ is negative. In other words, the first alternator is supplying the second with power, the difference between the two amounts of power represents the copper losses occasioned by the current I_s flowing through the circuit which possesses resistance. This power output of the first alternator tends to retard it, while the power input to the second one tends to accelerate it till such a time that E_1 and E_2 are again in phase opposition and the machines once again work in perfect synchronism. So, the action helps to keep both machines in stable synchronism. The current, I_s , is called the synchronizing current.

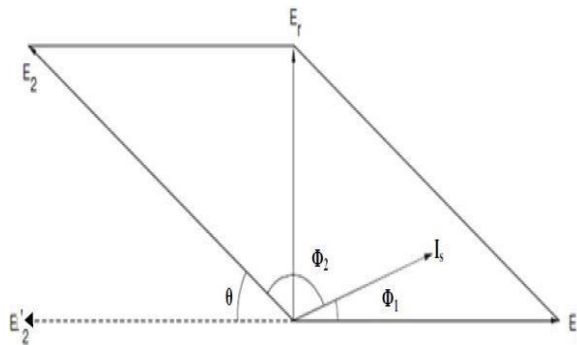

Figure: 3.2. Phasor diagram for synchronizing current.

Synchronizing Power

Suppose that one alternator has fallen behind its ideal position by an electrical angle θ , measured in radians. Since E_1 and E_2 are assumed equal and θ is very small E_r is very nearly equal to θE_1 . Moreover, since E_r is practically in quadrature with E_1 and I_s may be assumed to be in phase with E_1 as a first approximation. The synchronizing power may, therefore, be taken as,

$$P_s = E_1 I_s \quad \text{and} \quad I_s \approx \frac{E_r}{2Z_s} \quad \text{and} \quad E_r = \theta E_1$$

$$P_s \approx \frac{\theta E_1^2}{2Z_s} \quad \text{or} \quad P_s \approx \frac{\theta E_1^2}{2X_s}$$

Where Z_s is the synchronous impedance,

$Z_s = X_s$ when the resistance is neglected.

When one alternator is considered as running on a set of bus bars the power capacity of which is very large compared with its own, the combined reactance of the others sets connected to the bus bars is negligible, so that, in this case $Z_s = X_s$ is the synchronous reactance of the one alternator under consideration.

Total synchronizing power $P_{sy} = 3 \frac{E_1^2}{2Z_s}$ or

$$P_{sy} = 3 \frac{E_1^2}{2X_s}$$

When the machine is connected to an infinite bus bar the synchronizing power is given by

$$P_{sy} \approx \frac{E_1^2}{Z_s} \quad \text{or}$$

$$P_{sy} \approx \frac{E_1^2}{X_s}$$

And synchronizing torque $T_{sy} = P_{sy} \times 60 / 2\pi N_s$

Alternators with a large ratio of reactance to resistance are superior from a synchronizing point of view to those which have a smaller ratio, as then the synchronizing current I_s cannot

be considered as being in phase with E_1 . Thus, while reactance is bad from a regulation point of view, it is good for synchronizing purposes. It is also good from the point of view of self-protection in the event of a fault.

Effect of Change of Excitation

A change in the excitation of an alternator running in parallel with other affects only its KVA output; it does not affect the KW output. A change in the excitation, thus, affects only the power factor of its output. Let two similar alternators of the same rating be operating in parallel, receiving equal power inputs from their prime movers. Neglecting losses, their kW outputs are therefore equal. If their excitations are the same, they induce the same emf, and since they are in parallel their terminal voltages are also the same. When delivering a total load of I amperes at a power-factor of $\cos \phi$, each alternator delivers half the total current and $I_1 = I_2 = I/2$.

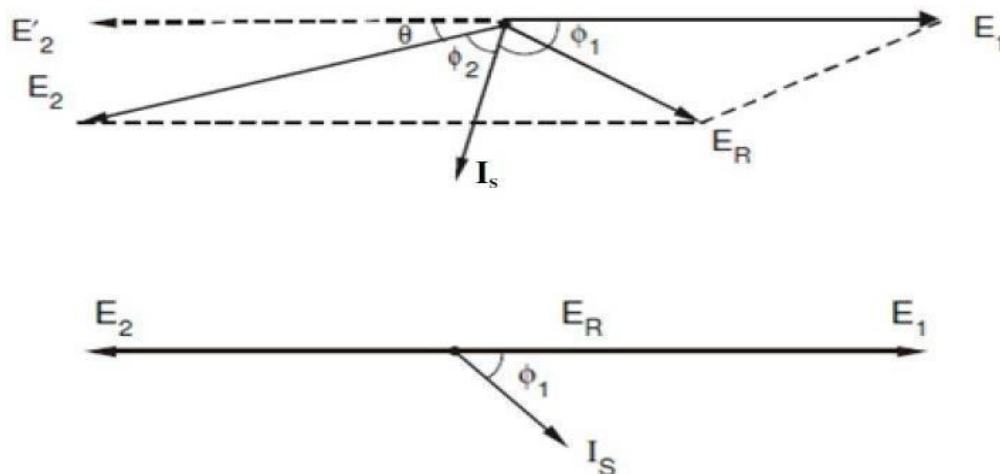

Figure: 3.3. Effect of change of excitation

Since their induced emfs are the same, there is no resultant emf acting around the local circuit formed by their two armature windings, so that the synchronizing current, I_s , is zero. Since the armature resistance is neglected, the vector difference between $E_1 = E_2$ and V is equal to, $I_1 X_{s1} - I_2 X_{s2}$, this vector leading the current I by 90° , where X_{s1} and X_{s2} are the synchronous reactances of the two alternators respectively.

Now consider the effect of reducing the excitation of the second alternator. E_2 is therefore reduced as shown in Figure. This reduces the terminal voltage slightly, so let the excitation of the first alternator be increased so as to bring the terminal voltage back to its original value. Since the two alternator inputs are unchanged and losses are neglected, the two kW outputs are the same as before. The current I_2 is changed due to the change in E_2 , but the active components of both I_1 and I_2 remain unaltered. It can be observed that there is a small change in the load angles of the two alternators, this angle being slightly increased in the case of the weakly excited alternator and slightly decreased in the case of the strongly excited alternator. It can also be observed that $I_1 + I_2 = I$, the total load current.

Effect of Change of Input Torque

The amount of power output delivered by an alternator running in parallel with others is governed solely by the power input received from its prime mover. If two alternators only are operating in parallel the increase in power input may be accompanied by a minute increase in their speeds, causing a proportional rise in frequency. This can be corrected by reducing the power input to the other alternator, until the frequency is brought back to its original value. In practice, when load is transferred from one alternator to another, the power input to the alternator required to take additional load is increased, the power input to the other alternator being simultaneously decreased. In this way, the change in power output can be effected without measurable change in the frequency. The effect of increasing the input to one prime mover is, thus, seen to make its alternator take an increased share of the load, the other being relieved to a corresponding extent. The final power-factors are also altered, since the ratio of the reactive components of the load has also been changed. The power-factors of the two alternators can be brought back to their original values, if desired, by adjusting the excitations of alternators.

Load Sharing

When several alternators are required to run in parallel, it probably happens that their rated outputs differ. In such cases it is usual to divide the total load between them in such a way that each alternator takes the load in the same proportion of its rated load in total rated outputs. The total load is not divided equally. Alternatively, it may be desired to run one large alternator permanently on full load, the fluctuations in load being borne by one or more of the others.

If the alternators are sharing the load equally the power triangles are as shown in figure below.

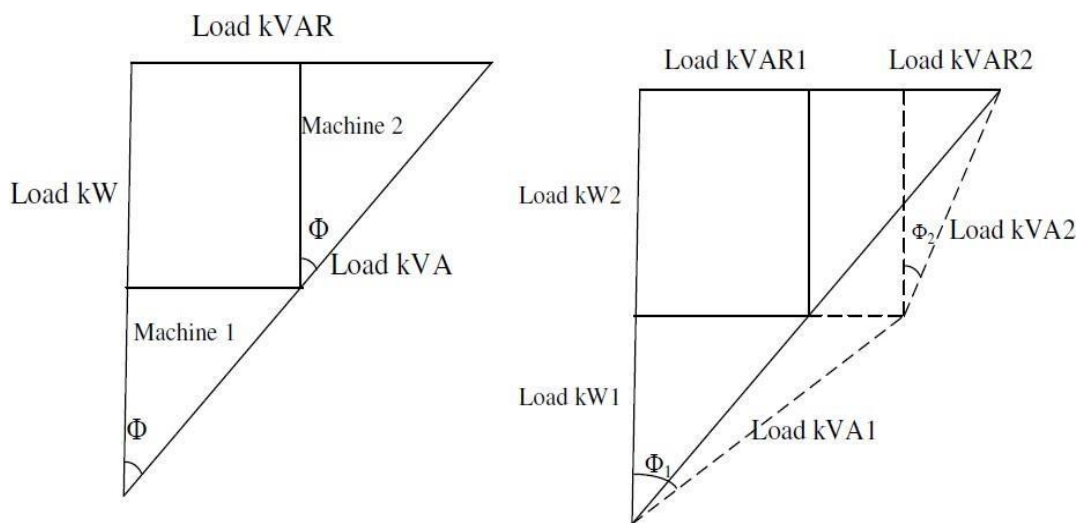

Figure: 3.4. Load sharing of alternators.

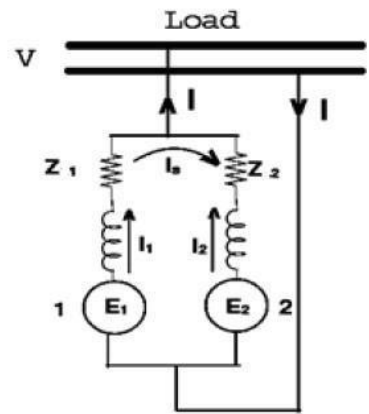
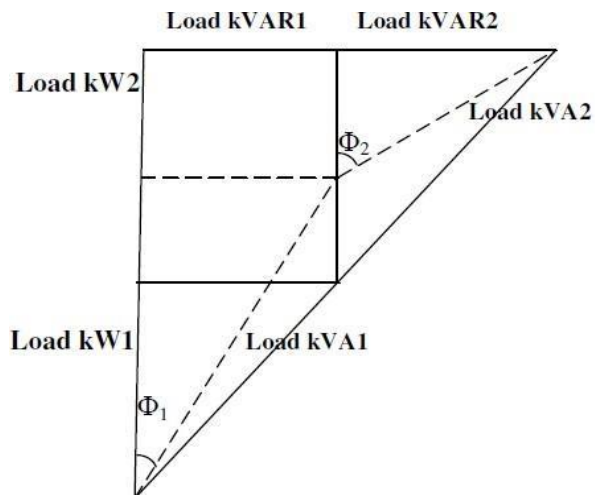

Figure: 3.5. Load sharing of alternators.

Sharing of load when two alternators are in parallel

Consider two alternators with identical speed load characteristics connected in parallel as

shown in figure above. Let E_1, E_2 be the induced emf per phase,

Z_1, Z_2 be the impedances per phase,

I_1, I_2 be the current supplied by each machine

per phase Z be the load impedance per phase,

V be the terminal voltage per phase

From the circuit we have $V = E_1 - I_1 Z_1 = E_2 - I_2 Z_2$ and hence

$$I_1 = E_1 - V/Z_1 \text{ and } I_2 = E_2 - V/Z_2$$

and also $V = (I_1 + I_2) Z = IZ$ solving above

$$\text{equations } I_1 = [(E_1 - E_2) Z + E_1 Z_2] / [$$

$$Z(Z_1 + Z_2) + Z_1 Z_2]$$

$$I_2 = [(E_2 - E_1) Z + E_2 Z_1] / [Z(Z_1 + Z_2) + Z_1 Z_2]$$

$$\text{The total current } I = I_1 + I_2 = [E_1 Z_2 + E_2 Z_1] / [Z(Z_1 + Z_2) + Z_1 Z_2]$$

And the circulating current or synchronizing current $I_s = (E_1 - E_2) / (Z_1 + Z_2)$

UNIT-IV

SYNCHRONOUS MOTORS

Principle of operation

In order to understand the principle of operation of a synchronous motor, assume that the armature winding (laid out in the stator) of a 3-phase synchronous machine is connected to a suitable balanced 3-phase source and the field winding to a D.C source of rated voltage. The current flowing through the field coils will set up stationary magnetic poles of alternate North and South. On the other hand, the 3-phase currents flowing in the armature winding produce a rotating magnetic field rotating at synchronous speed. In other words there will be moving North and South poles established in the stator due to the 3-phase currents i.e. at any location in the stator there will be a North Pole at some instant of time and it will become a South Pole after a time period corresponding to half a cycle. (After a time = $1/2f$, where f = frequency of the supply). Assume that the stationary South pole in the rotor is aligned with the North pole in the stator moving in clockwise direction at a particular instant of time, as shown in Figure below. These two poles get attracted and try to maintain this alignment (as per Lenz's law) and hence the rotor pole tries to follow the stator pole as the conditions are suitable for the production of torque in the clockwise direction. However, the rotor cannot move instantaneously due to its mechanical inertia, and so it needs some time to move.

In the mean time, the stator pole would quickly (a time duration corresponding to half a cycle) change its polarity and becomes a South Pole. So the force of attraction will no longer be present and instead the like poles experience a force of Repulsion as shown in Figure below. In other words, the conditions are now suitable for the production of torque in the anticlockwise direction. Even this condition will not last longer as the stator pole.

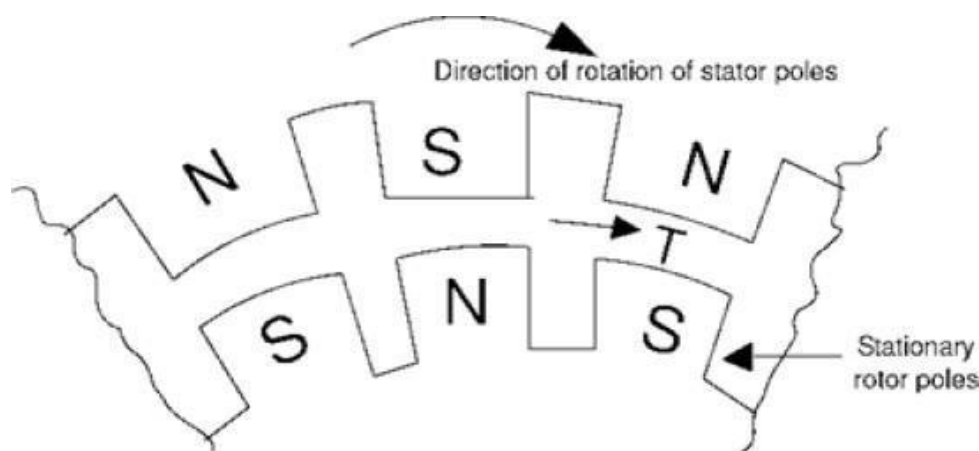

Figure: 4.1. Force of attraction between stator poles and rotor poles - resulting in production of torque in clockwise direction.

Would again change to North pole after a time of $1/2f$. Thus the rotor will experience an alternating force which tries to move it clockwise and anticlockwise at twice the frequency of the supply, i.e. at intervals corresponding to $1/2f$ seconds. As this duration is quite small compared to the mechanical time constant of the rotor, the rotor cannot respond and move in any direction. The rotor continues to be stationary only.

On the contrary if the rotor is brought to near synchronous speed by some external device say a small motor mounted on the same shaft as that of the rotor, the rotor poles get locked to the unlike poles in the stator and the rotor continues to run at the synchronous speed even if the supply to the motor is disconnected. Thus the synchronous rotor cannot start rotating on its own when the rotor and stator are supplied with rated voltage and frequency and hence the synchronous motor has no starting torque. So, some special provision has to be made either inside the machine or outside of the machine so that the rotor is brought to near about its

synchronous speed. At that time, if the armature is supplied with electrical power, the rotor can pull into step and continue to run at its synchronous speed. Some of the commonly used methods for starting synchronous rotor are described in the following paragraph.

Would again change to North Pole after a time of $1/2f$. Thus the rotor will experience an alternating force which tries to move it clockwise and anticlockwise at twice the frequency of the supply, i.e. at intervals corresponding to $1/2f$ seconds. As this duration is quite small compared to the mechanical time constant of the rotor, the rotor cannot respond and move in any direction. The rotor continues to be stationary only.

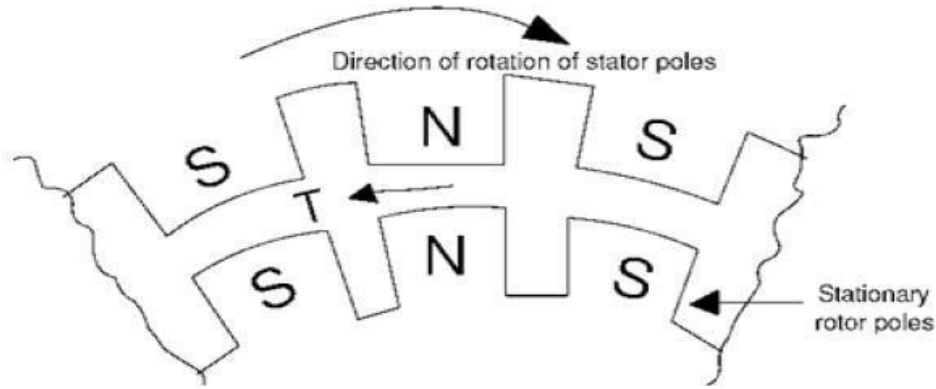

Figure: 4.2. Force of repulsion between stator poles and rotor poles - resulting in production of torque in anticlockwise direction

Methods of starting synchronous motor

Basically there are three methods that are used to start a synchronous motor:

- To reduce the speed of the rotating magnetic field of the stator to a low enough value that the rotor can easily accelerate and lock in with it during one half-cycle of the rotating magnetic field's rotation. This is done by reducing the frequency of the applied electric power. This method is usually followed in the case of inverter-fed synchronous motor operating under variable speed drive applications.
- To use an external prime mover to accelerate the rotor of synchronous motor near to its synchronous speed and then supply the rotor as well as stator. Of course care should be taken to ensure that the directions of rotation of the rotor as well as that of the rotating magnetic field of the stator are the same. This method is usually followed in the laboratory- the synchronous machine is started as a generator and is then connected to the supply mains by following the synchronization or paralleling procedure. Then the power supply to the prime mover is disconnected so that the synchronous machine will continue to operate as a motor.
- To use damper windings if these are provided in the machine. The damper windings are provided in most of the large synchronous motors in order to nullify the oscillations of the rotor whenever the synchronous machine is subjected to a periodically varying load.

Behaviour of a synchronous motor

The behaviour of a synchronous motor can be predicted by considering its equivalent circuit on similar lines to that of a synchronous generator as described below.

Equivalent circuit model and phasor diagram of a synchronous motor

The equivalent-circuit model for one armature phase of a cylindrical rotor three phase synchronous motor is shown in Figure below exactly similar to that of a synchronous generator except that the current flows in to the armature from the supply. Applying Kirchhoff's voltage law to Figure below

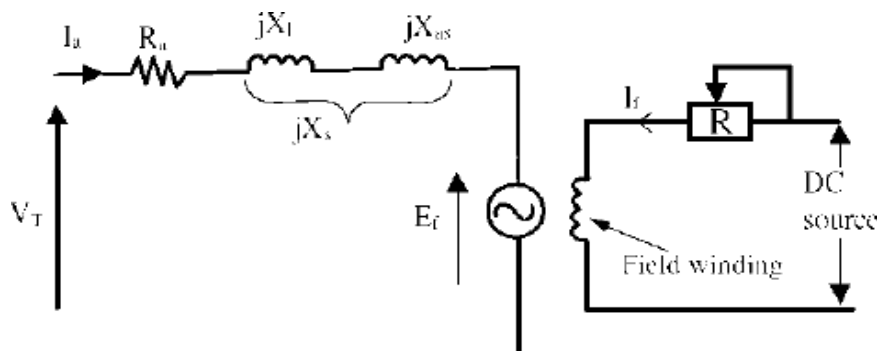

Figure: 4.3. Equivalent circuit model for one phase of a synchronous motor armature $V_T = I_a R_a + j I_a X_l + j I_a X_{as} + E_f$

Combining reactances, $X_s = X_l + X_a$

$$V_T = E_f + I_a(R_a + jX_s)$$

$$\text{or } V_T = E_f + I_a Z_s$$

where:

R_a = armature resistance (/phase)

X_l = armature leakage reactance (/phase)
 X_s = synchronous reactance (/phase)

Z_s = synchronous impedance (/phase)

V_T = applied voltage/phase (V)

I_a = armature current/phase (A)

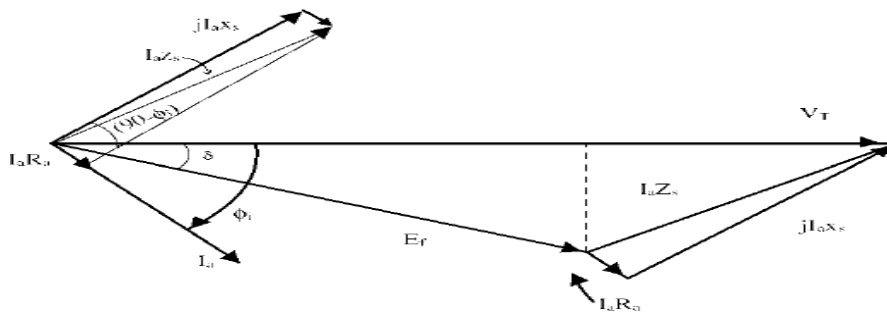

Figure: 4.4. Phasor diagram corresponding to the equivalent-circuit model

A phasor diagram shown in Figure above, illustrates the method of determining the counter EMF which is obtained from the phasor equation;

$$E_f = V_T - I_a Z_s$$

The phase angle δ between the terminal voltage V_T and the excitation voltage E_f in Figure above is usually termed the torque angle. The torque angle is also called the load angle or power angle.

Effect of changes in load on, I_a , δ , and p. f. of synchronous motor

The effects of changes in mechanical or shaft load on armature current, power angle, and power factor can be seen from the phasor diagram shown in Figure below; As already stated, the applied stator voltage, frequency, and field excitation are assumed, constant. The initial load conditions are represented by the thick lines. The effect of increasing the shaft load to twice its initial value is represented by the light lines indicating the new steady state conditions. While drawing the phasor diagrams to show new steady-state conditions, the line of action of the new $jI_a X_s$ phasor must be perpendicular to the new I_a phasor. Furthermore, as shown in figure if the excitation is not changed, increasing the shaft load causes the locus of the E_f phasor to follow a circular arc, thereby increasing its phase angle with increasing shaft load. Note also that an increase in shaft load is also accompanied by a decrease in Φ_i ; resulting in an increase in power factor.

As additional load is placed on the machine, the rotor continues to increase its angle of lag relative to the rotating magnetic field, thereby increasing both the angle of lag of the counter EMF phasor and the magnitude of the stator current. It is interesting to note that during all this load variation; however, except for the duration of transient conditions whereby the rotor assumes a new position in relation to the rotating magnetic field, the average speed of the machine does not change. As the load is being increased, a final point is reached at which a further increase in δ fails to cause a corresponding increase in motor torque, and the rotor pulls out of synchronism. In fact as stated earlier, the rotor poles at this point, will fall behind the stator poles such that they now come under the influence of like poles and the force of attraction no longer exists. Thus, the point of maximum torque occurs at a power angle of approximately 90° for a cylindrical-rotor machine. This maximum value of torque that causes a synchronous motor to pull out of synchronism is called the pull-out torque. In actual practice, the motor will never be operated at power angles close to 90° as armature current

will be many times its rated value at this load.

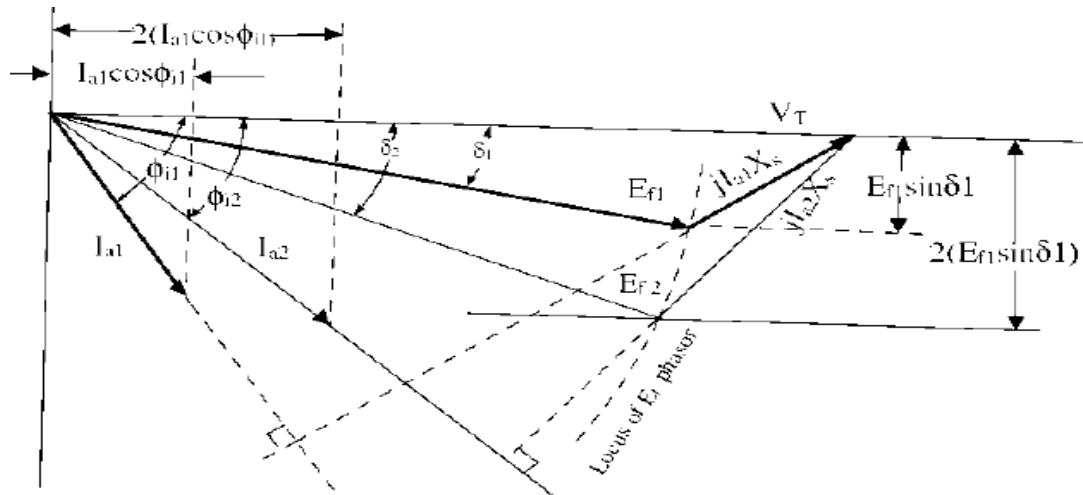

Figure: 4.5. Effect of changes in load on, I_a , δ , and p. f.

Effect of changes in excitation on the performance synchronous motor

Increasing the strength of the magnets will increase the magnetic attraction, and thereby cause the rotor magnets to have a closer alignment with the corresponding opposite poles of the rotating magnetic poles of the stator. This will obviously result in a smaller power angle. This fact can also be seen from power angle equation. When the shaft load is assumed to be constant, the steady-state value of $E_f \sin \delta$ must also be constant. An increase in E_f will cause a transient increase in $E_f \sin \delta$, and the rotor will accelerate. As the rotor changes its angular position, δ decreases until $E_f \sin \delta$ has the same steady-state value as before, at which time the rotor is again operating at synchronous speed, as it should run only at the synchronous speed. This change in angular position of the rotor magnets relative to the poles of rotating magnetic field of the stator occurs in a fraction of a second. The effect of changes in field excitation on armature current, power angle, and power factor of a synchronous motor operating with a constant shaft load, from a constant voltage, constant frequency supply, is illustrated in figure below.

$$E_{f1} \sin \delta_1 = E_{f2} \sin \delta_2 = E_{f3} \sin \delta_3 = E_f \sin \delta$$

This is shown in Figure below, where the locus of the tip of the E_f phasor is a straight line parallel to the V_T phasor. Similarly,

$$I_{a1} \cos \Phi_{i1} = I_{a2} \cos \Phi_{i2} = I_{a3} \cos \Phi_{i3} = I_a \cos \Phi_i$$

This is also shown in Figure below, where the locus of the tip of the I_a phasor is a line perpendicular to the phasor V_T .

Note that increasing the excitation from E_{f1} to E_{f3} caused the phase angle of the current phasor with respect to the terminal voltage V_T (and hence the power factor) to go from lagging to leading. The value of field excitation that results in unity power factor is called normal excitation. Excitation greater than normal is called over excitation, and excitation less than normal is called under excitation.

Further, as indicated in Figure, when operating in the overexcited mode, $|E_f| > |V_T|$. A

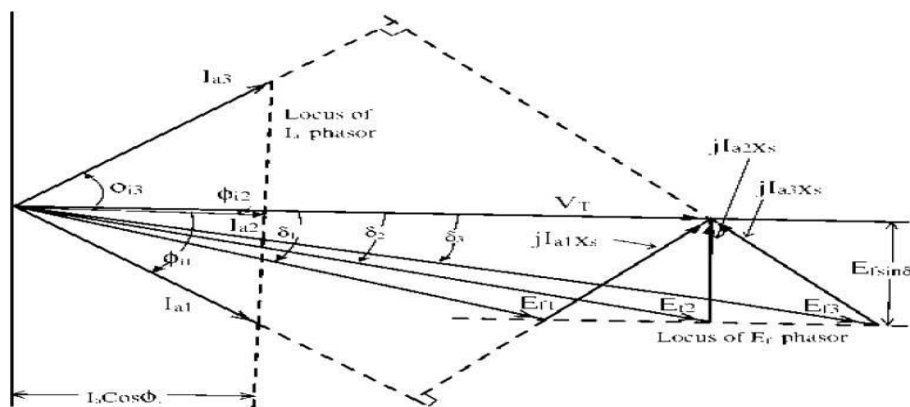

synchronous motor operating under over excited condition is called a synchronous condenser.

Figure: 4.6. Phasor diagram showing effect of changes in field excitation on armature current, power angle and power factor of a synchronous motor

V and inverted V curve of synchronous motor

Graphs of armature current vs. field current of synchronous motors are called V curves and are shown in Figure below for typical values of synchronous motor loads. The curves are related to the phasor diagram shown in figure below, and illustrate the effect of the variation of field excitation on armature current and power factor. It can be easily noted from these curves that an increase in shaft loads require an increase in field excitation in order to maintain the power factor at unity.

The points marked *a*, *b*, and *c* on the upper curve corresponds to the operating conditions of the phasor diagrams shown. Note that for $P = 0$, the lagging power factor operation is electrically equivalent to an inductor and the leading power factor operation is electrically equivalent to a capacitor. Leading power factor operation with $P = 0$

is sometimes referred to as synchronous condenser or synchronous capacitor operation. Typically, the synchronous machine V-curves are provided by the manufacturer so that the user can determine the resulting operation under a given set of conditions.

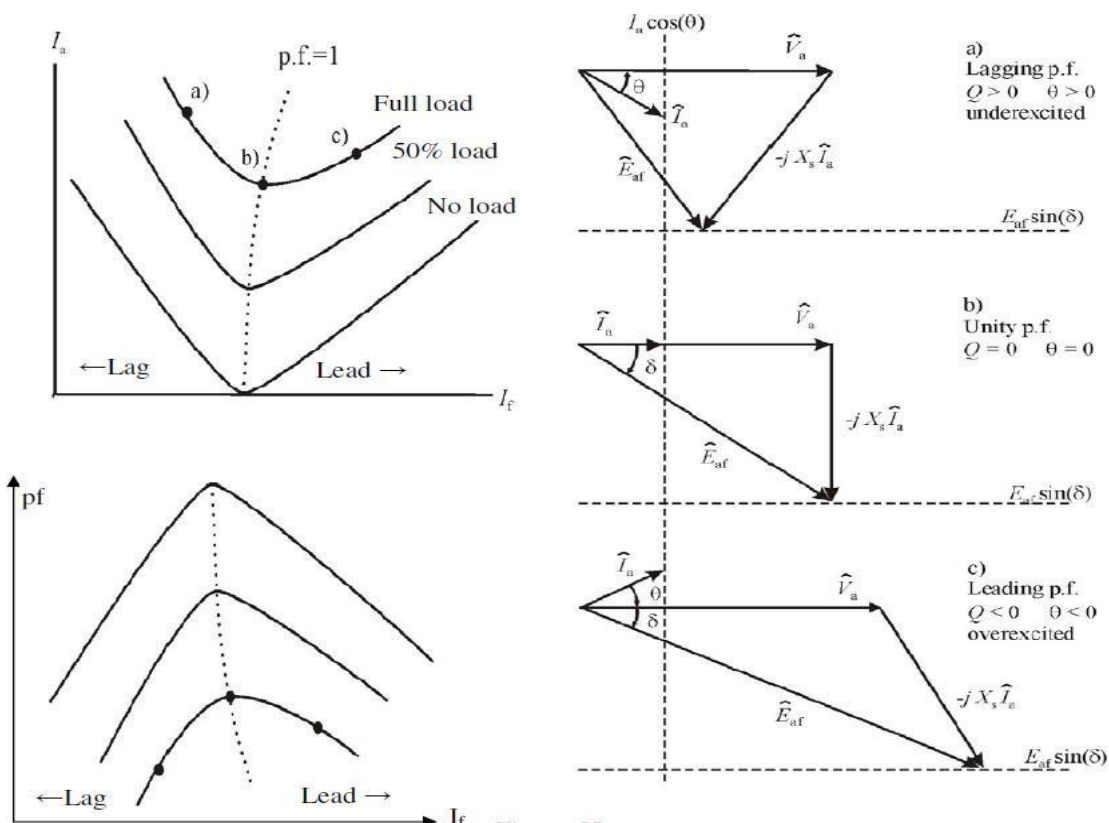

Figure: 4.7. Plots of power factor vs. field current of synchronous motors are called inverted V curves and are shown in Figure above for different values of synchronous motor loads.

Power Flow in Synchronous Motor

The figure below gives the details regarding the power flow in synchronous motor.

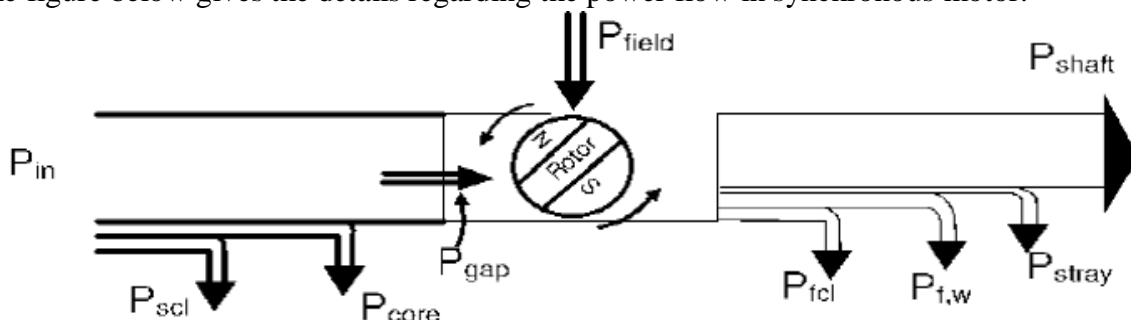

Figure: 4.8. Power stages in synchronous motor.

Where

P_{in} = Power input to the motor
 P_{scl} = Power loss as stator copper loss
 P_{core} = Power loss as core loss
 P_{gap} = Power in the air gap
 P_{fcl} = Power loss as field copper loss
 P_{fw} = Power loss as friction and windage loss
 P_{stray} = Power loss as stray loss
 P_{shaft} = Shaft output of the machine

Power input to a synchronous motor is given by $P = 3V_{ph}I_{ph}\cos\Phi = \sqrt{3}V_L I_L \cos\Phi$. In stator as per the diagram there will be core loss and copper losses taking place. The remaining power will be converted to gross mechanical power.
Hence $P_m = \text{Power input to the motor} - \text{Total losses in stator}$.

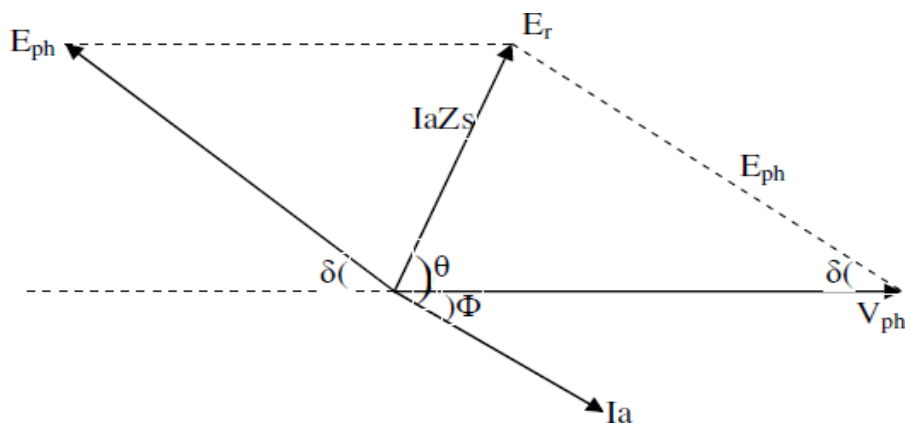

Figure: 4.9. Phasor diagram

From the phasor diagram we can write Power input /phase $P_i = V_{ph}I_{ph}\cos\Phi$
Mechanical power developed by the motor $P_m = E_b I_a \cos(\delta - \Phi)$
Assuming iron losses as negligible stator cu losses = $P_i - P_m$
Power output /phase = $P_m - (\text{field cu loss} + \text{friction \& windage loss} + \text{stray loss})$

Torque developed in Motor

Mechanical power is given by $P_m = 2\pi N_s T_g / 60$ where N_s is the synchronous speed and the T_g is the gross torque developed.

$$P_m = 2\pi N_s T_g / 60$$

$$\text{Hence } T_g = \frac{P_m}{2\pi N_s} \times 60$$

$$T_g = 9.55 \frac{P_m}{N_s} \text{ N-m}$$

$$\text{Shaft output torque } T_{sh} = 60 \times \frac{P_{out}}{2\pi N_s}$$

$$T_{sh} = 9.55 \frac{P_{out}}{N_s} \text{ N-m}$$

Hunting and Damper

Winding Hunting

Sudden changes of load on synchronous motors may sometimes set up oscillations that are superimposed upon the normal rotation, resulting in periodic variations of a very low frequency in speed. This effect is known as hunting or phase-swinging. Occasionally, the trouble is aggravated by the motor having a natural period of oscillation approximately equal to the hunting period. When the synchronous motor phase-swings into the unstable region, the motor may fall out of synchronism.

Damper winding

The tendency of hunting can be minimized by the use of a damper winding. Damper windings are placed in the pole faces. No emfs are induced in the damper bars and no current

flows in the damper winding, which is not operative. Whenever any irregularity takes place in the speed of rotation, however, the polar flux moves from side to side of the pole, this movement causing the flux to move backwards and forwards across the damper bars. Emfs are induced in the damper bars forwards across the damper winding. These tend to damp out the superimposed oscillatory motion by absorbing its energy. The damper winding, thus, has no effect upon the normal average speed, it merely tends to damp out the oscillations in the speed, acting as a kind of electrical flywheel. In the case of a three-phase synchronous motor the stator currents set up a rotating mmf rotating at uniform speed and if the rotor is rotating at uniform speed, no emfs are induced in the damper bars.

Synchronous Condenser

An over excited synchronous motor operates at unity or leading power factor. Generally, in large industrial plants the load power factor will be lagging. The specially designed synchronous motor running at zero load, taking leading current, approximately equal to 90° . When it is connected in parallel with inductive loads to improve power factor, it is known as synchronous condenser. Compared to static capacitor the power factor can improve easily by variation of field excitation of motor. Phasor diagram of a synchronous condenser connected in parallel with an inductive load is given below.

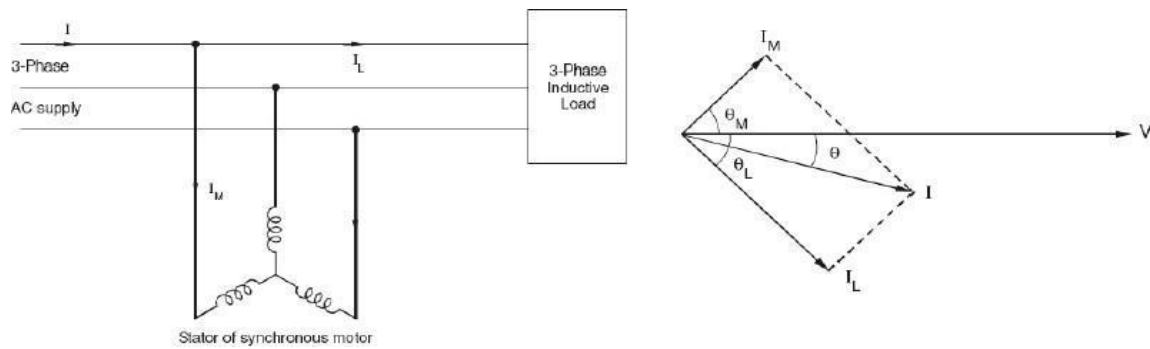

Figure: 4.10. Synchronous condenser and phasor diagram

UNIT-V

SINGLE PHASE MOTORS & SPECIAL MACHINES

Introduction

The characteristics of single phase induction motors are identical to 3-phase induction motors except that single phase induction motor has no inherent starting torque and some special arrangements have to be made for making itself starting. It follows that during starting period the single phase induction motor must be converted to a type which is not a single phase induction motor in the sense in which the term is ordinarily used and it becomes a true single phase induction motor when it is running and after the speed and torque have been raised to a point beyond which the additional device may be dispensed with. For these reasons, it is necessary to distinguish clearly between the starting period when the motor is not a single phase induction motor and the normal running condition when it is a single phase induction motor. The starting device adds to the cost of the motor and also requires more space. For the same output a 1-phase motor is about 30% larger than a corresponding 3-phase motor.

The single phase induction motor in its simplest form is structurally the same as a poly-phase induction motor having a squirrel cage rotor, the only difference is that the single phase induction motor has single winding on the stator which produces mmf stationary in space but alternating in time, a poly phase stator winding carrying balanced currents produces mmf rotating in space around the air gap and constant in time with respect to an observer moving with the mmf. The stator winding of the single phase motor is disposed in slots around the inner periphery of laminated rings similar to the 3-phase motor.

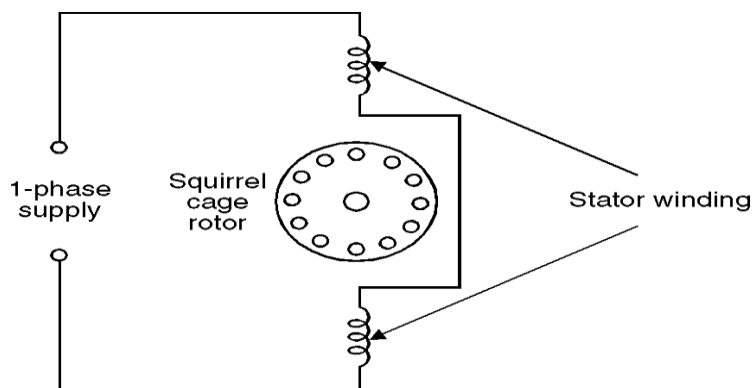

Figure: 5.1. Elementary single phase induction motor

An induction motor with a cage rotor and single phase stator winding is shown schematically in Fig. 5.1. The actual stator winding as mentioned earlier is distributed in slots so as to produce an approximately sinusoidal space distribution of mmf.

Principle of Operation

Suppose the rotor is at rest and 1-phase supply is given to stator winding. The current flowing in the stator winding gives rise to an mmf whose axis is along the winding and it is a pulsating mmf, stationary in space and varying in magnitude, as a function of time, varying from positive maximum to zero to negative maximum and this pulsating mmf induces currents in the short-circuited rotor of the motor which gives rise to an mmf. The currents in the rotor are induced due to transformer action and

the direction of the currents is such that the mmf so developed opposes the stator mmf. The axis of the rotor mmf is same as that of the stator mmf. Since the torque developed is proportional to sine of the angle between the two mmf and since the angle is zero, the net torque acting on the rotor is zero and hence the rotor remains stationary.

For analytical purposes a pulsating field can be resolved into two revolving fields of constant magnitude and rotating in opposite directions as shown in Fig. 5.2 and each field has a magnitude equal to half the maximum length of the original pulsating phasor.

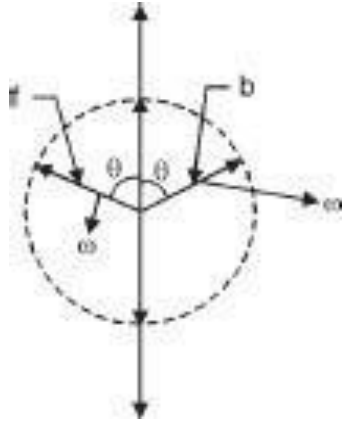

Figure: 5.2. Representation of the pulsating field by space phasors.

These component waves rotate in opposite direction at synchronous speed. The forward (anticlockwise) and backward-rotating (clockwise) mmf waves f and b are shown in Fig. 5.2. In case of 3- phase induction motor there is only one forward rotating magnetic field and hence torque is developed and the motor is self-starting. However, in single phase induction motor each of this component mmf waves produces induction motor action but the corresponding torques are in opposite direction. With the rotor at rest the forward and backward field produce equal torques but opposite in direction and hence no net torque is developed on the motor and the motor remains stationary. If the forward and backward air gap fields remained equal when the rotor is revolving, each of the component fields would produce a torque-speed characteristic similar to that of a Poly phase induction motor with negligible leakage impedance as shown by the dashed curves f and b in Fig. 5.3.

The resultant torque-speed characteristic which is the algebraic sum of the two component curves shows that if the motor were started by auxiliary means it would produce torque in what- ever direction it was started.

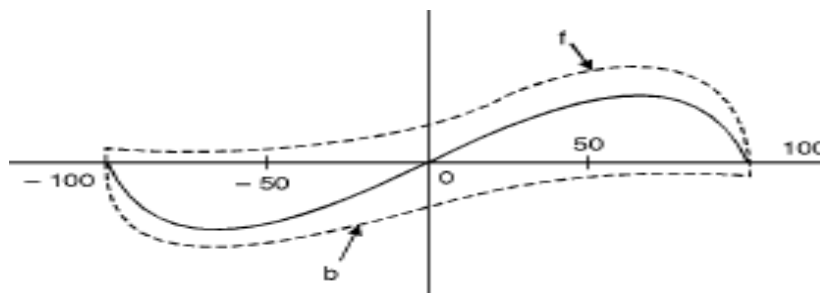

Figure: 5.3. Torque-speed characteristic of a 1-phase induction motor based on constant forward and backward flux waves.

In reality the two fields, forward and backward do not remain constant in the air gap and also the effect of stator leakage impedance can't be ignored. In the above qualitative analysis the effects of induced rotor currents have not been properly accounted for.

When single phase supply is connected to the stator and the rotor is given a push

along the forward rotating field, the relative speed between the rotor and the forward rotating magnetic field goes on decreasing and hence the magnitude of induced currents also decreases and hence the mmf due to the induced current in the rotor decreases and its opposing effect to the forward rotating field decreases which means the forward rotating field becomes stronger as the rotor speeds up. However for the backward rotating field the relative speed between the rotor and the backward field increases as the rotor rotates and hence the rotor emf increases and hence the mmf due to this component of current increases and its opposing effect to the backward rotating field increases and the net backward rotating field weakens as the rotor rotates along

the forward

rotating field. However, the sum of the two fields remains constant since it must induce the stator or counter emf which is approximately constant if the stator leakage impedance drop

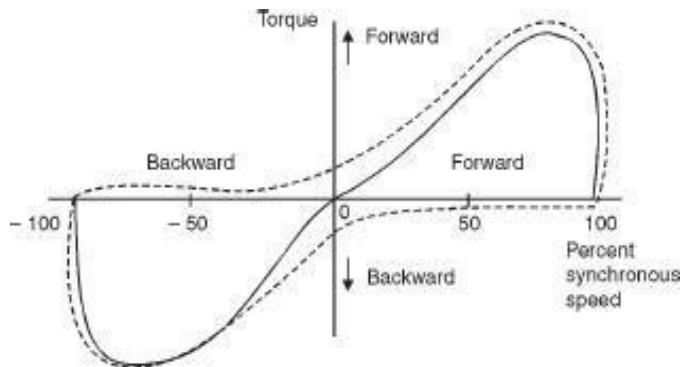

is negligible. Hence, with the rotor in motion the torque of the forward field is greater and that of the backward field is less than what is shown in Fig. 5.3. The true situation being as is shown in Fig. 5.4.

Figure: 5.4. Torque-speed characteristic of a 1-phase induction motor taking into account changes in the flux waves.

In the normal running region at a few per cent slip the forward field is several times stronger than the backward field and the flux wave does not differ materially from the constant

Amplitude revolving field in the air gap of a balanced poly phase motor. Therefore, in the normal running range of the motor, the torque-speed characteristic of a single phase motor is not very much different from that of a poly phase motor having the same rotor and operating with the same maximum air gap flux density.

In addition to the torque shown in Fig. 5.4, double-stator frequency torque pulsations are produced by the interaction of the oppositely rotating flux and mmf waves which move past each other at twice synchronous speed. These double frequency torques produce no average torque as these pulsations are sinusoidal and over the complete cycle the average torque is zero. However, sometimes these are additive to the main torque and for another half a cycle these are subtractive and therefore a variable torque acts on the shaft of the motor which makes the motor noisier as compared to a poly phase induction motor where the total torque is constant. Such torque pulsations are unavoidable in single phase circuits. Mathematically

$$\begin{aligned}
 T &\propto I^2 \\
 I &= I_m \sin \omega t \\
 T &= K I_m^2 \sin^2 \omega t \\
 &= K I_m^2 (1 - \cos 2\omega t) / 2
 \end{aligned}$$

Starting Of Single Phase Induction Motors

The single phase induction motors are classified based on the method of starting method and in fact are known by the same name descriptive of the method. Appropriate

selection of these motors depends upon the starting and running torque requirements of the load, the duty cycle and limitations on starting and running current drawn from the supply by these motors. The cost of single phase induction motor increases with the size of the motor and with the performance such as starting torque to current ratio (higher ratio is desirable), hence, the user will like to go in for a smaller size (hp) motor with minimum cost, of course, meeting all the operational requirements. However, if a very large no. of fractional horsepower motors are required, a specific design can always be worked out which might give minimum cost for a given performance requirements. Following are the starting methods.

(a) Split-phase induction motor. The stator of a split phase induction motor has two windings, the main winding and the auxiliary winding. These windings are displaced in space by 90 electrical degrees as shown in Fig. 9.5 (a). The auxiliary winding is made of thin wire (super enamel copper wire) so that it has a high R/X ratio as compared to the main winding which has thick super enamel copper wire. Since the two windings are connected across the supply the

Torque is developed and the motor becomes a self-starting motor. After the motor starts, the auxiliary winding is disconnected usually by means of centrifugal switch that operates at about 75 per cent of

synchronous speed. Finally the motor runs because of the main winding. Since this being single phase some level of humming noise is always associated with the motor during Running. A typical torque speed characteristic is shown. It is to be noted that the direction of rotation of the motor can be reversed by reversing the connection to either the main winding or the auxiliary windings.

Current I_m and I_a in the main winding and auxiliary winding lag behind the supply voltage V , I_a leading the current I_m . This means the current through auxiliary winding reaches maximum value first and the mmf or flux due to I_a lies along the axis of the auxiliary winding and after some time ($t = \tau/\omega$) the current I_m reaches maximum value and the mmf or flux due to I_m lies along the main winding axis. Thus the motor becomes a 2-phase unbalanced motor. It is unbalanced

Since the two currents are not exactly 90 degrees apart. Because of these two fields a starting

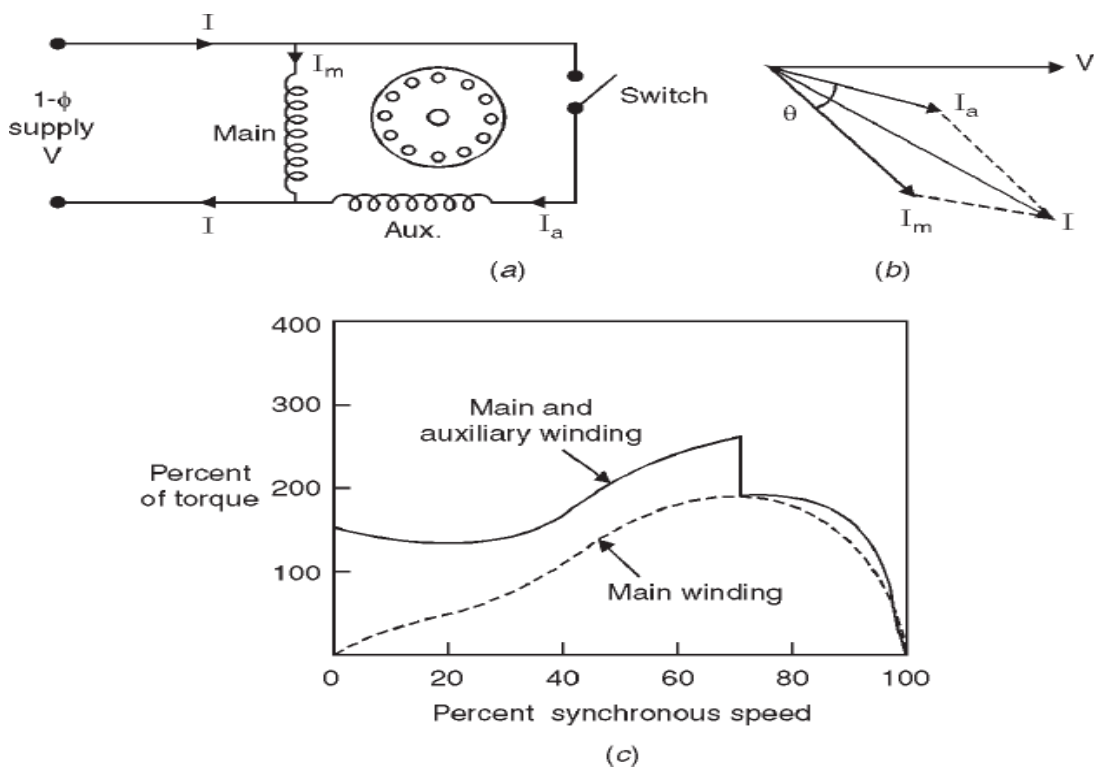

Figure: 5.5. Split phase induction motor (a) Connection

(b) Phasor diagram at starting (c) typical torque-speed characteristic.

(b) **Capacitor starts induction motor:** Capacitors are used to improve the starting and running performance of the single phase induction motors.

The capacitor start induction motor is also a split phase motor. The capacitor of suitable value is connected in series with the auxiliary coil through a switch such that I_a the current in the auxiliary coil leads the current I_m in the main coil by 90 electrical degrees in time phase so that the starting torque is maximum for certain values of I_a and I_m . This becomes a balanced 2-phase motor if the magnitude of I_a and I_m are equal and are displaced in time phase by 90° electrical degrees. Since the two windings are displaced in space by 90 electrical degrees as shown in Fig. 9.6 maximum torque is developed at start. However, the auxiliary winding and capacitor are disconnected after the motor has picked up 5 per cent of the synchronous speed. The motor will start without any humming noise. However, after the auxiliary

winding is disconnected, there will be some humming noise.

Since the auxiliary winding and capacitor are to be used intermittently, these can be designed for minimum cost. However, it is found that the best compromise among the factors of starting torque, starting current and costs results with a phase angle somewhat less than 90°

between I_m and I_a . A typical torque-speed characteristic is shown in Fig. 5.6 (c) high starting torque being an outstanding feature.

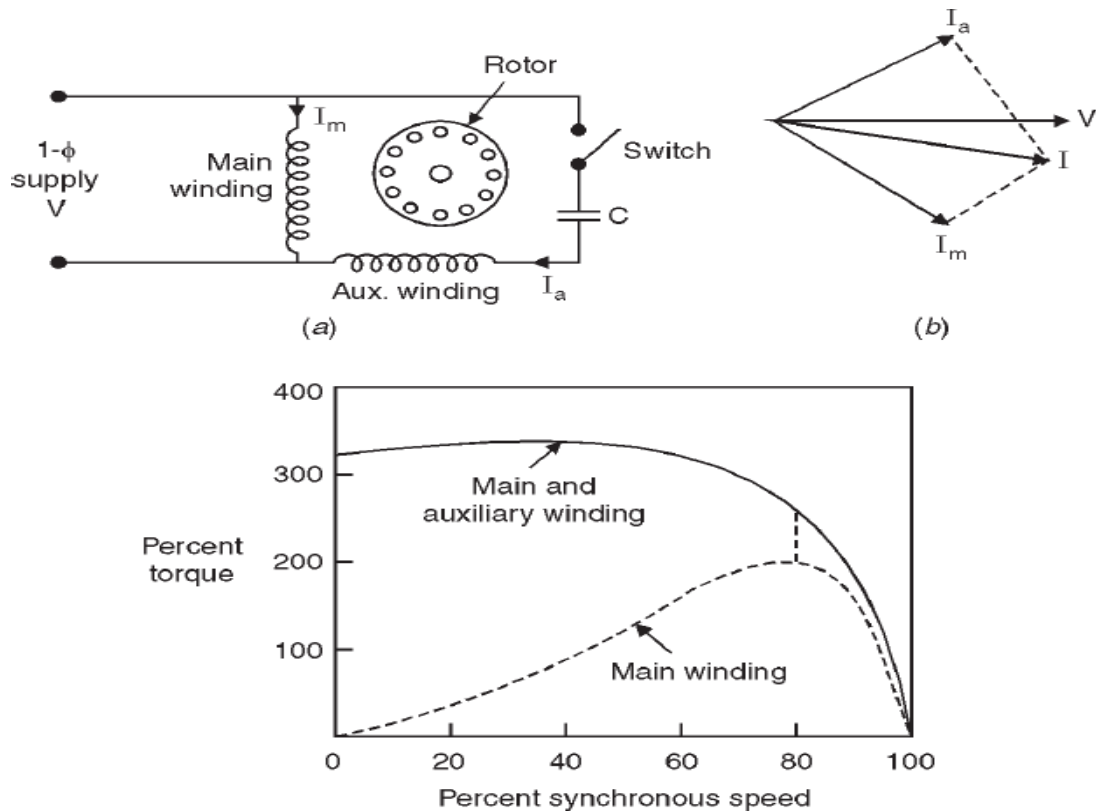

Figure: 5.6. Capacitor start motor (a) Connection
(b) Phasor diagram at start (c) Speed torque curve.

(c) Permanent-split capacitor motor. In this motor the auxiliary winding and capacitor are not disconnected from the motor after starting, thus the construction is simplified by the omission of the switch as shown in Fig. 5.7(a).

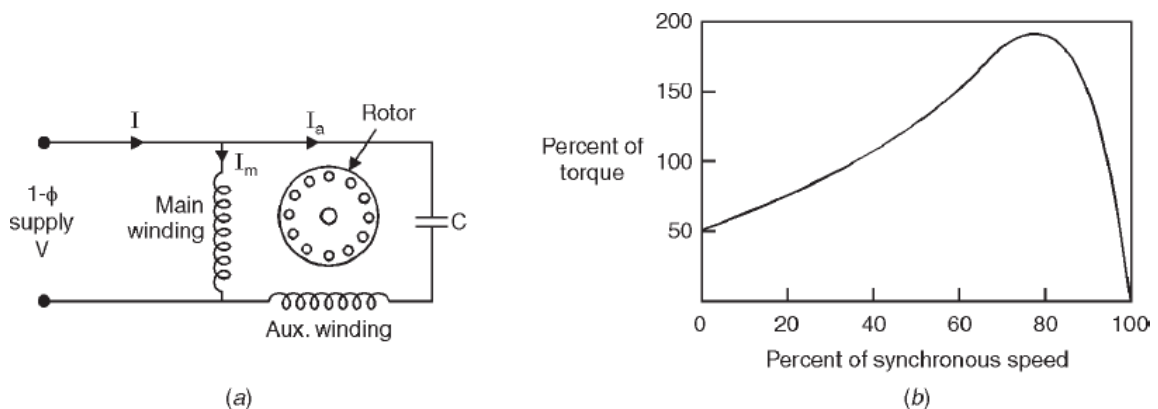

Figure: 5.7. Permanent split capacitor motor (a) Connection (b) Torque-speed characteristic.

Here the auxiliary winding and capacitor could be so designed that the motor works as a perfect 2-phase motor at anyone desired load. With this the backward rotating magnetic field would be completely eliminated. The double stator frequency torque pulsations would also be eliminated, thereby the motor starts and runs as a noise free

motor. With this there is improvement in p.f. and efficiency of the motor. However, the starting torque must be sacrificed as the

capacitance is necessarily a compromise between the best starting and running characteristics. The torque-speed characteristic of the motor is shown in Fig. 9.7 (b).

(c) Capacitor start capacitor run motor. If two capacitors are used with the auxiliary winding as shown in Fig. 5.8 (a), one for starting and other during the start and run, theoretically optimum starting and running performance can both be achieved.

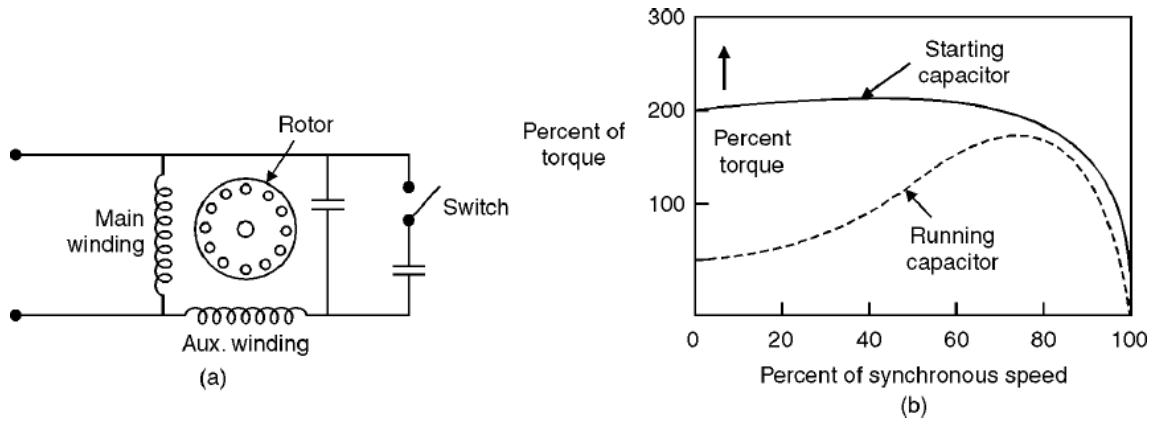

Fig. 5.8. (a) Capacitor start capacitor run motor (b) Torque-speed characteristic.

The small value capacitor required for optimum running conditions is permanently connected in series with the auxiliary winding and the much larger value required for starting is obtained by a capacitor connected in parallel with the running capacitor. The starting capacitor is disconnected after the motor starts.

The value of the capacitor for a capacitor start motor is about $300\mu\text{F}$ for 1/2 hp motor
Since

This capacitor must carry current for a short starting period; the capacitor is a special compact ac Electrolytic type made for motor starting duty. However, the capacitor permanently connected has a typical rating of $40\mu\text{F}$; since it is connected permanently, the capacitor is an ac paper, foil and oil type. The cost of the motor is related to the performance; the permanent capacitor motor is the lowest cost, the capacitor start motor next and the capacitor start capacitor run has the highest cost.

(c) Shaded pole induction motor. Fig. 5.9 (a) shows schematic diagram of shaded pole induction motor. The stator has salient poles with one portion of each pole surrounded by a short-circuited turn of copper called a shading coil. Induced currents in the shading coil (acts as an inductor) cause the flux in the shaded portion of the pole to lag the flux in the other portion. Hence the flux under the unshaded pole leads the flux under the shaded pole which results in a rotating field moving in the direction from unshaded to the shaded portion of the pole and a low starting torque is produced which rotates the rotor in the direction from unshaded to the shaded pole. A typical torque speed characteristic is shown in Fig. 5.9 (b). The efficiency is low. These motors are the least expensive type

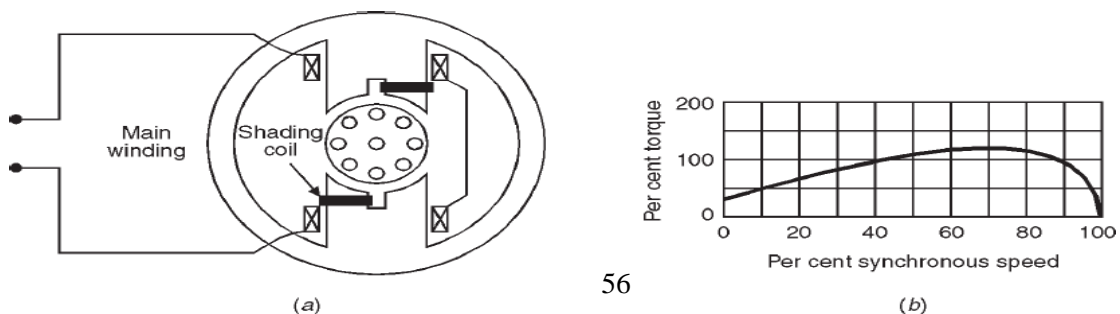

of fractional horse power motor and are built up to about 1/20 hp. Since the rotation of the motor is in the direction from unshaded towards the shaded part of the pole, a shaded pole motor can be reversed only by providing two sets of shading coils which may be opened and closed or it may be reversed permanently by inverting the core.

Figure: 5.9. Shaded-pole motor and typical torque-speed characteristic.

Universal Motor

We know that single phase motors are not self starting. We have to provide additional features to make itself starting.

The other solution to the single phase problem is to design a d.c. motor so that it will run on a.c. as well. The direction of rotation of a d.c. machine depends upon the polarities of the armature circuit and the field circuit. If a d.c. machine is designed so that (i) when line current reverses direction the field and armature currents reverse simultaneously and (ii) the core loss with alternating flux is relatively low, then a successful single phase machine results.

The first criterion is met by connecting armature and field windings in series. The second is achieved by using a laminated core. A d.c. shunt motor on the other hand cannot be used on a.c. because of high inductance of the field winding as compared to armature winding which causes the field pole reversals to be out of phase with the current reversals in the armature and the result is that the torque is backward during part of each half cycle lowering average torque and reducing the efficiency.

A d.c. series motor designed to operate also on a.c. is called a universal motor as it will run efficiently on any frequency from d.c. upto its design frequency. Fig. 5.10

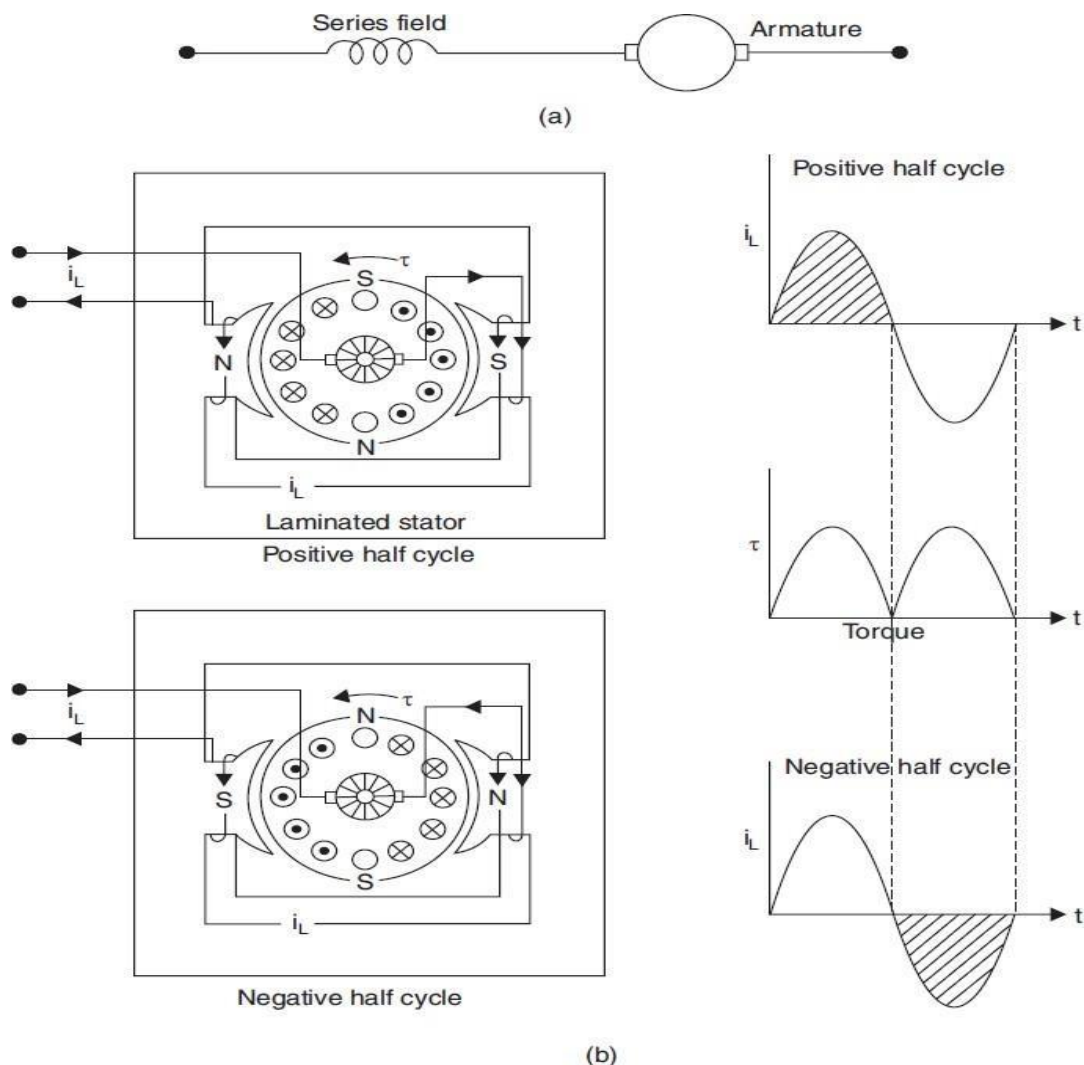

shows the principle of operation of the motor.

Figure 5.10 The universal motor. (a) Circuit diagram. (b) Principle of operation.

Universal motors are designed for voltages ranging from 32 to 250 volts, frequencies zero to 60Hz and ratings upto 3/4 hp. The average speed is high in the range of 1000 rpm at normal load. The

torque/speed characteristic of the motor is shown in Fig. 5.11 No load speed is quite high often in the range of 20,000 rpm. It is limited by windage and friction. Having high speed capability, universal motor of a given horse power rating is significantly smaller than other kinds of a.c. motors operating at the same frequency. Their starting torque is relatively high. These characteristics make universal motors ideal for devices such as hand drills, hand grinders, food mixers, vacuum cleaners and the like which require compact motors operating at speeds greater than 3000/3600 rpm. Universal motors must be designed with weak magnetic fields to minimize commutation difficulties. High resistance carbon brushes are used to limit the circulating current due to the transformer voltage in the short circuited coils.

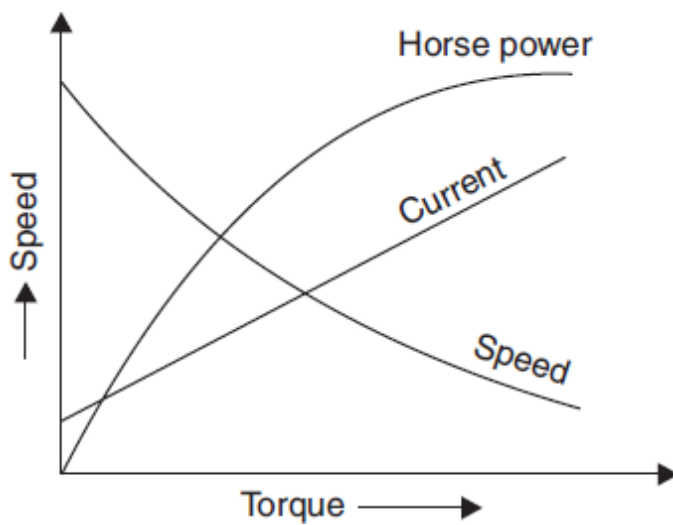

Figure: 5.11 Characteristics of universal motors

Stepper motors

A special type of synchronous motor which is designed to rotate a specific number of degrees for every electric pulse received by its control unit. Typical steps are 7.5 or 15° per pulse. It is a motor that can rotate in both directions, move in precise angular increments, sustain a holding torque at zero speed, and be controlled with digital circuits. It moves in accurate angular increments known as steps, in response to the application of digital pulses to the electric drivecircuit.

Generally, such motors are manufactured with steps per revolution. Step motors are either bipolar, requiring two power sources or uni polar requiring only one power source.

$$\Theta_m = 2/p * \theta_e$$

$$w_m = 2/p * w_e$$

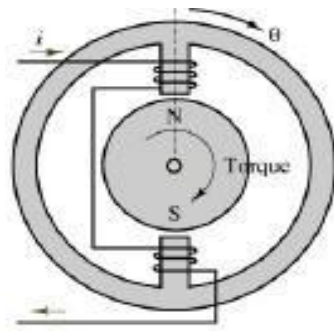

(a) Permanent-magnet stepping motor

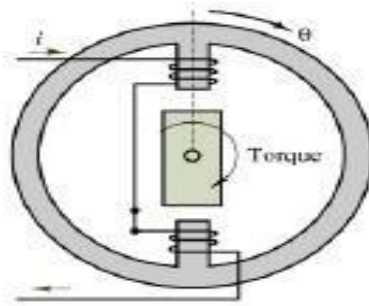

(b) Variable-reluctance stepping motor

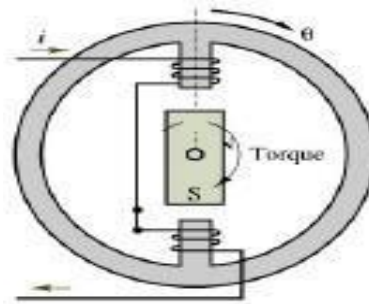

(c) Hybrid stepping motor