

# **MALLA REDDY COLLEGE OF ENGINEERING & TECHNOLOGY**

**(Autonomous Institution – UGC, Govt. of India)**

Recognized under 2(f) and 12 (B) of UGC ACT 1956

(Affiliated to JNTUH, Hyderabad, Approved by AICTE - Accredited by NBA & NAAC –  
'A' Grade - ISO 9001:2015 Certified)

Maisammaguda, Dhulapally (Post Via. Kompally), Secunderabad – 500100, Telangana  
State, India



## **DEPARTMENT OF ELECTRICAL & ELECTRONICS ENGINEERING**

**DIGITAL NOTES for POWER SYSTEMS - II (R18A0208)**

*For*

***B.Tech (EEE) – III YEAR – I SEMESTER***

**Prepared by**

***O. SAIDULU REDDY***



**(R18A0208) POWER SYSTEMS-II**

**COURSE OBJECTIVES:**

- To design the insulators for overhead lines
- Understand the construction and grading of cables in power transmission.
- To examine A.C. and D.C distribution systems.
- To examine the traveling wave performance and sag of transmission lines.

**UNIT-I:**

**OVERHEAD LINE INSULATORS, SAG AND TENSION CALCULATIONS:** Types of Insulators, String efficiency and Methods for improvement, Numerical Problems - voltage distribution, calculation of string efficiency, Capacitance grading and Static Shielding Sag and Tension Calculations with equal and unequal heights of towers, Effect of Wind and Ice on weight of Conductor, Numerical Problems - Stringing chart and sag template and its applications.

**UNIT-II:**

**UNDERGROUND CABLES:** Types of Cables, Construction, Types of Insulating materials, Calculations of Insulation resistance and stress in insulation, Numerical Problems. Capacitance of Single and 3-Core belted cables, Numerical Problems. Grading of Cables - Capacitance grading, Potential grading Numerical Problems, Description of Inter-sheath grading - HV cables.

**UNIT-III:**

**D.C DISTRIBUTION SYSTEMS:** Classification of Distribution Systems –Comparison of DC vs. AC and Underground vs. Overhead Distribution Systems - Requirements and Design features of Distribution Systems. Voltage Drop Calculations (Numerical Problems) in D.C Distributors for the following cases: Radial D.C Distributor fed one end and at the both the ends (equal / unequal Voltages) and Ring Main Distributor.

**UNIT- IV:**

**A.C DISTRIBUTION SYSTEMS:** Voltage Drop Calculations (Numerical Problems) in A.C. distributors for the following cases: Power Factors referred to receiving end voltage and with respect to respective load voltages. Industrial and commercial distribution systems – Energy losses in distribution system – system ground for safety and protection.

**UNIT-V:**

**SUBSTATIONS:** Classification of substations – Air insulated substations – Indoor & Outdoor substations: Substations layout showing the location of all the substation equipment. Bus b a r arrangements in the S u b -Stations: Simple arrangements like single busbar, sectionalized single busbar, main and transfer busbar system with relevant diagrams.

**TEXT BOOKS:**

1. A Text Book on Power System Engineering by M.L. Soni, P.V. Gupta, U.S. Bhatnagar,
2. Electrical power systems - by C.L Wadhwa, New Age International (P) Limited, Publishers, 1998.

3. "C. L. Wadhwa", "Generation and utilization of Electrical Energy", New age International (P)Limited, Publishers1997.

**REFERENCE BOOKS:**

1. Power system Analysis-by John J Grainger William D Stevenson, TMC Companies, 4th edition.
2. Power System Analysis and Design by B.R. Gupta, Wheeler Publishing
3. Power System Analysis by Hadi Sadat – TMH Edition.

**COURSE OUTCOMES:**

- Understand A.C. and D.C. distribution systems.
- Able to analyze the performance of distribution lines
- Able to analyze the performance of Sag and Tension Calculations
- Can understand transient's phenomenon of transmission lines.
- Able to understand overhead line insulators and underground cables.
- Able to distinguish between air and gas insulated substations.

<b>S.NO</b>	<b>TITLE</b>	<b>PAGE.NO</b>
<b>UNIT I - OVERHEAD LINE INSULATORS, SAG AND TENSION CALCULATIONS</b>		
1.	Introduction to Mechanical Design of Transmission Line	01
2.	Sag and Tension Calculations with equal and unequal heights of towers	02
3.	Effect of Wind and Ice on weight of Conductor	05
4.	Stringing chart	07
5.	Sag template and its applications	08
6.	Types of Insulators	11
7.	Voltage distribution of String Insulator	16
8.	String efficiency	17
9.	Methods for improvement of String efficiency	19
10.	Capacitance grading and Static Shielding	22
<b>UNIT II - UNDERGROUND CABLES</b>		
11.	Introduction	25
12.	Construction of Cables	26
13.	Types of Insulating materials	27
14.	Classification of Cables	28
15.	Calculations of Insulation resistance and stress in insulation	29
16.	Capacitance of Single Core belted cables	31
17.	Capacitance of 3- Core belted cables	33
18.	Grading of Cables - Capacitance grading	37
19.	Description of Inter-sheath grading	39
20.	HV cables	41
<b>UNIT III - D.C DISTRIBUTION SYSTEMS</b>		
21.	Introduction	43
22.	Classification of Distribution Systems	44
23.	Comparison of DC vs. AC	49

24.	Underground vs. Overhead Distribution Systems	50
25.	Design features of Distribution Systems	51
26.	Requirements of Distribution Systems	52
27.	DC Distributor Fed at One End — Concentrated Loading	56
28.	Uniformly Loaded Radial D.C Distributor Fed at One End	57
29.	Distributor Fed at Both Ends — Concentrated Loading with equal / unequal Voltages	58
30.	Uniformly Loaded Distributor Fed at Both Ends with equal / unequal Voltages	60
31.	Distributor with Both Concentrated and Uniform Loading	63
32.	Ring Main Distributor.	63
<b>UNIT IV - A.C DISTRIBUTION SYSTEMS</b>		
33.	Voltage Drop Calculations in A.C. distributors	65
34.	Power factors referred to receiving end voltage	65
35.	Power factors referred to respective load voltages	67
36.	Energy losses in distribution system	68
37.	System grounding	73
38.	Methods of Neutral Grounding	75
39.	Solid Grounding	77
40.	Resistance Grounding	79
41.	Reactance Grounding	80
42.	Arc Suspension Grounding (Or Resonant Grounding)	81
<b>UNIT V - SUBSTATIONS</b>		
43.	Classification of substations	83
44.	Air insulated substations	86
45.	Substation Layout	87
46.	Indoor and Outdoor Substations	88
47.	Components of Sub-Stations	92
48.	Busbar Arrangements in Substations:	95
49.	Terminal and Through Substations:	98
50.	Single Bus-Bar Arrangement	100

51.	Single Bus-Bar Arrangement with Bus Sectionalization	101
52.	Main and Transfer Bus Arrangement	102
53.	Double Bus Double Breaker Arrangement	103
54.	Sectionalized Double Bus Arrangement	104
55.	One-and a Half Breaker Arrangement	105
56.	Ring Main Arrangement	106
57.	Mesh Arrangement	107

## UNIT -I

### OVERHEAD LINE INSULATORS, SAG AND TENSION CALCULATIONS

#### INTRODUCTION TO MECHANICAL DESIGN OF TRANSMISSION LINE:

We know that the overhead line conductors are supported on the tower structure by means of line insulators. These conductors, which are made of copper or aluminum or its alloys have its own weight, especially in extra high voltage transmission line these conductors are very heavy. Due to its weight it exerts pressure on the insulators and the towers thus stress at the point of supports as well as the conductors are also subjected to high tension. It is very important that conductors are under safe tension. If the conductors are too much stretched between supports in a bid to save conductor material, the stress in the conductor may reach unsafe value and in certain cases the conductor may break due to excessive tension. In order to permit safe tension in the conductors, they are not fully stretched but are allowed to have a dip or sag.

The difference in level between points of supports and the lowest point on the conductor is called sag. The conductor sag should be kept to a minimum in order to reduce the conductor material required and to avoid extra pole height for sufficient clearance above ground level. It is also desirable that tension in the conductor should be low to avoid the mechanical failure of conductor and to permit the use of less strong supports. However, low conductor tension and minimum sag are not possible. It is because low sag means a tight wire and high tension, whereas a low tension means a loose wire and increased sag. Therefore, in actual practice, a compromise is made between the sag and tension.

#### Sag in Overhead Transmission Line:

While erecting an overhead line, it is very important that conductors are under safe tension. If the conductors are too much stretched between supports in a bid to save conductor material, the stress in the conductor may reach unsafe value and in certain cases the conductor may break due to excessive tension. In order to permit safe tension in the conductors, they are not fully stretched but are allowed to have a dip or sag. The difference in level between points of supports and the lowest point on the conductor is called sag. Following Fig. 8.1 shows a conductor suspended between two equal level supports A and B. The conductor is not fully stretched but is allowed to have a dip. The lowest point on the conductor is O and the sag is S.

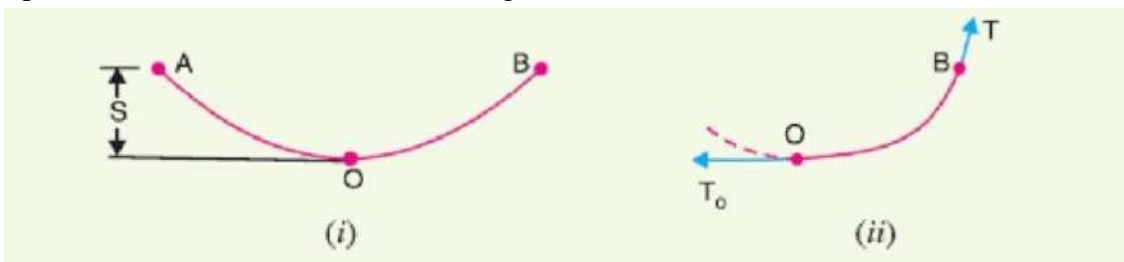

Fig 2.4- Sag in a transmission line

The following points may be noted:

- (i) When the conductor is suspended between two supports at the same level, it takes the shape

of catenary. However, if the sag is very small compared with the span, then sag-span curve is like a parabola.

(ii) The tension at any point on the conductor acts tangentially. Thus tension  $T_0$  at the lowest Point  $O$  acts horizontally as shown in Fig. (ii).

(iii) The horizontal component of tension is constant throughout the length of the wire.

(iv) The tension at supports is approximately equal to the horizontal tension acting at any point on the wire. Thus if  $T$  is the tension at the support  $B$ , then  $T = T_0$ .

### Conductor sag and tension:

This is an important consideration in the mechanical design of Over head lines. The conductor sag should be kept to a minimum in order to reduce the conductor material required and to avoid extra pole height for sufficient clearance above ground level. It is also desirable that tension in the conductor should be low to avoid the mechanical failure of conductor and to permit the use of less strong supports. However, low conductor tension and minimum sag are not possible. It is because low sag means a tight wire and high tension, whereas a low tension means a loose wire and increased sag. Therefore, in actual practice, a compromise is made between the two.

### CALCULATION OF SAG

A conductor is suspended between two supports 'A' and 'B' as shown in Fig.-6.1. The lowest point on the conductor is 'O' and the sag is 'd'. When the conductor is suspended between two supports at the same level, it takes the shape of catenary. However, if the sag is very small compared with the span, then sag-span curve is like a parabola. The tension at any point on the conductor acts tangentially. Thus tension 'T' at the lowest point 'O' acts horizontally as shown. The horizontal component of tension is constant throughout the length of the wire. The tension at supports is approximately equal to the horizontal tension acting at any point on the wire.

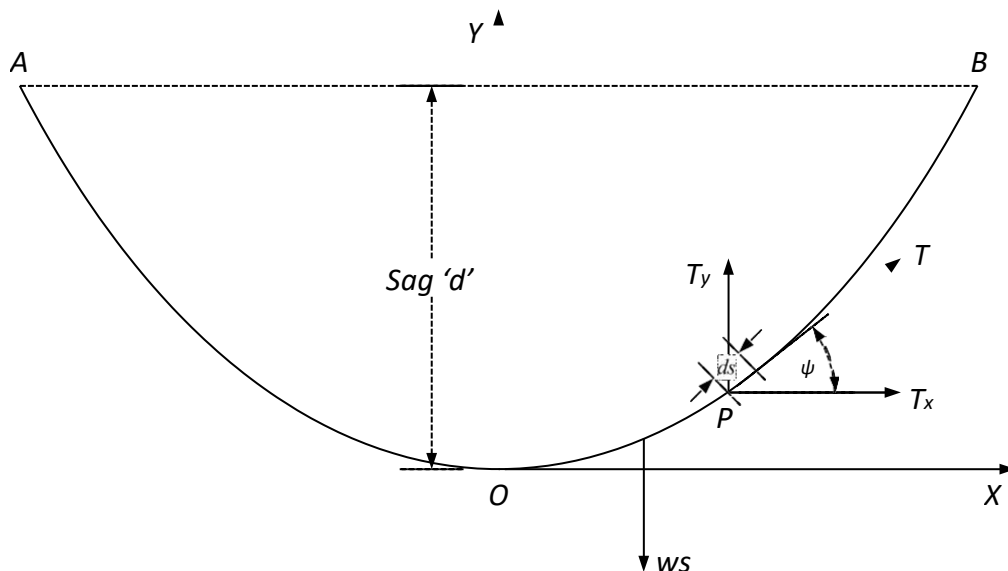

Fig.-6.1 Span of transmission line showing the conductor sag and tension (supports at same level)

Let us consider an elemental length of the conductor 'ds' at point 'P' on the conductor at the length of 's' from the center point 'O' (*minimum point of the conductor*). We can write the

vertical component and horizontal component of tension acting on the elemental length as follows.

$T_x = H$  and  $T_y = ws$  where 'w' is the weight of the conductor per unit length of the conductor. At point 'P'

$$\tan\psi = \frac{dy}{dx} = \frac{T_y}{T_x} = \frac{ws}{H} \quad (6.1)$$

For the elemental length of the conductor we can write

$$ds = \sqrt{dx^2 + dy^2} \Rightarrow \frac{ds}{dx} = \sqrt{1 + \left(\frac{dy}{dx}\right)^2} = \sqrt{1 + \left(\frac{ws}{H}\right)^2} \quad (6.2)$$

Integrating and solving for constant we get

$$s = \frac{H}{w} \operatorname{Sinh} \frac{wx}{H} \quad (6.3)$$

Thus from (6.1) and (6.3) we get after solving for constant

$$y = \frac{H}{w} \left( \operatorname{Cosh} \frac{wx}{H} - 1 \right) \quad (6.4)$$

(6.4) is the equation of catenary. At point 'P' the tension 'T' is given by

$$T = \sqrt{T_x^2 + T_y^2} = \sqrt{H^2 + (ws)^2} \quad (6.5)$$

Using (6.3) in (6.5) we get

$$T = H \operatorname{Cosh} \frac{wx}{H} \quad (6.6)$$

If the span length is '2l' then half span is 'l', hence the length of the conductor in half span, sag and tension can be given by (6.7)

$$S = \frac{H}{w} \operatorname{Sinh} \frac{wl}{H} \quad (6.7a)$$

$$\text{Sag } d' = y_A - y_B = \frac{H}{w} \left( \operatorname{Cosh} \frac{wl}{H} - 1 \right) \quad (6.7b)$$

$$T = T_A = T_B = H \operatorname{Cosh} \frac{wl}{H} \quad (6.7c)$$

(6.7) can be approximated to

$$s = l + \frac{w^2 \ell^3}{6T^2} \quad (6.8a)$$

$$y = \frac{w \ell^2}{2T} = d \quad (6.8b)$$

$$\frac{T}{H} = 1 + \frac{(w \ell)^2}{2H^2} \quad (6.8c)$$

Substituting for  $l = \frac{L}{2}$  in (6.8)

$$s = \frac{L}{2} + \frac{w^2 L^3}{48T^2} \quad (6.8a)$$

$$d = y = \frac{wL^2}{8T} \quad (6.8b)$$

$$T = H \left( 1 + \frac{w^2 L^2}{8H^2} \right) \quad (6.8c)$$

In hilly areas, we generally come across conductors suspended between supports at unequal levels as shown in Fig.-6.2. Where 'h' is the difference between the two supports.

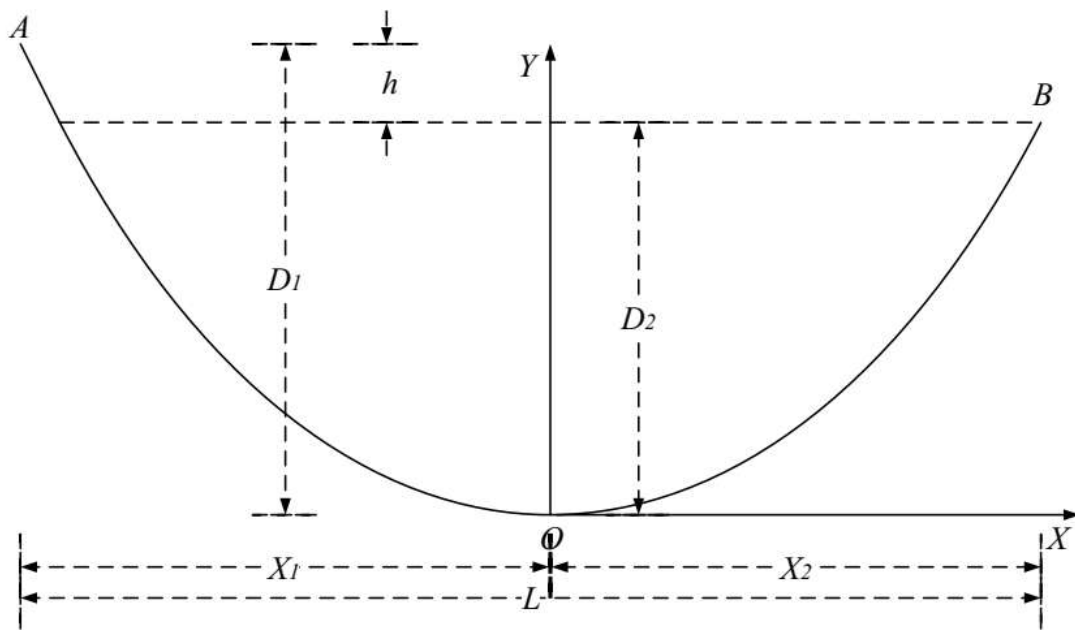

FIG.-6.2 SPAN OF TRANSMISSION LINE SHOWING THE CONDUCTOR SAG AND TENSION  
(SUPPORTS AT DIFFERENT LEVEL)

For such case the sag calculated from two supports are given by

$$D_1 = \frac{wx_1^2}{2T} \quad (6.9a)$$

$$D_2 = \frac{wx_2^2}{2T} \quad (6.9b)$$

$$h = D_1 - D_2 = \frac{w}{2T} (x_1^2 - x_2^2) \quad (6.9c)$$

$$\therefore (x_1 + x_2) = L$$

$$h = \frac{wL}{2T} (x_1 - x_2) \quad (6.10)$$

Where

$$x_1 = \frac{L}{2} + \frac{Th}{wL} \quad \text{and} \quad x_2 = \frac{L}{2} - \frac{Th}{wL}$$

**Effect of wind and ice loading-** The above formulae for sag are true only in still air and at normal temperature when the conductor is acted by its weight only. However, in actual practice,

a conductor may have ice coating and simultaneously subjected to wind pressure. The weight of ice acts vertically downwards i.e., in the same direction as the weight of conductor. The force due to the wind is assumed to act horizontally i.e., at right angle to the projected surface of the conductor. Hence, the total force on the conductor is the vector sum of horizontal and vertical forces as shown in

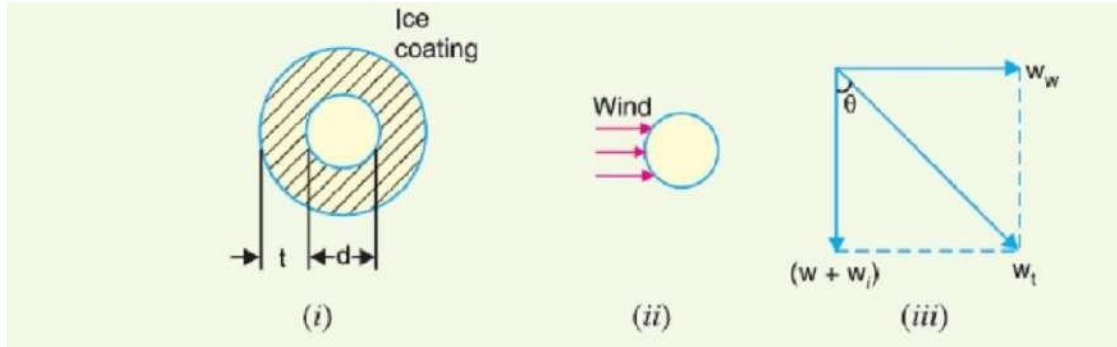

Fig 2.6- Effect of Ice and Wind

$w_i$  = weight of ice per unit length

= density of ice \* volume of ice per unit length

$$= \text{density of ice} \times \frac{\pi}{4} [(d + 2t)^2 - d^2] \times 1$$

$w_w$  = wind force per unit length

= wind pressure per unit area  $\times$  projected area per unit length

$$= \text{wind pressure} \times [(d + 2t) \times 1]$$

Total weight of conductor per unit length is

$$w_t = \sqrt{(w + w_i)^2 + w_w^2}$$

Where  $w$  = weight of conductor per unit length

= conductor material density  $\times$  volume per unit length

## STRINGING CHARTS

There are two factors which vary the sag and tension. These are elasticity and temperature. For use in the field work of stringing the conductors, temperature-sag and temperature-tension charts are plotted for the given conductor and loading conditions. Such curves are called stringing charts. These charts are very helpful while stringing overhead lines.

The conductor length and sag at temperature ' $\theta_1$ ' is given by  $s_1 = \ell + \frac{w^2 \ell^3}{6A^2 f_1^2}$  and

$d_1 = \frac{w \ell^2}{2A f_1}$ . Where ' $f_1$ ' is the stress tension per cross section area of the conductor.

If temperature is increased from  $\theta_1 \rightarrow \theta_2$  then the sag and tension changes as follows:

$$s_2 = s_1 - \left( \frac{f_1 - f_2}{E} \right) + (\theta_2 - \theta_1) \alpha \ell$$

$$s_2 = \ell + \frac{w_2^2 \ell^3}{6 f_2^2 A^2}$$

' $\alpha$ '-temperature coefficient of thermal expansion

## VIBRATION DAMPER

Aeolian vibrations mostly occur at steady wind velocities from 1 to 7 m/s. With increasing wind turbulences the wind power input to the conductor will decrease. The intensity to induce vibrations depends on several parameters such as type of conductors and clamps, tension, span length, topography in the surrounding, height and direction of the line as well as the frequency of occurrence of the vibration induced wind streams.

In the wake of wind power plants (up to 3 x diameter of the rotor behind the plant) the wind velocity will be reduced up to 0,5 of the velocity of the free wind stream, so that lower wind velocities could be expected more frequently here. That's why the probability of a higher stresses for the conductors caused by wind-induced vibrations will be greater than without wind power plants.

On the other hand the intensity of turbulences will increase which will hinder the arising of vibrations. The both important parameters for inducing vibrations, wind velocity and turbulence intensity, depends on the distance to the rotor and the height of it.

The investigations showed an increasing of damage probability on OHTL due to the wake of wind power plants of the factor 2,5 to 3,5 between one and three rotor diameters behind the plant which will cause an equivalent decreasing of lifetime of conductors and earth wires.

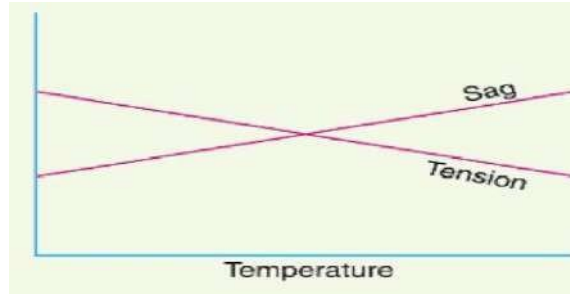

Fig 2.7- Stringing Chart

**SAG TEMPLATE:**

A Sag Template is a very important tool with the help of which the position of towers on the Profile is decided so that they conform to the limitations of vertical and wind loads on any particular tower, and minimum clearances, as per I.E. Rules, required to be maintained between the line conductor to ground, telephone lines, buildings, streets, navigable canals, power lines, or any other object coming under or near the line.

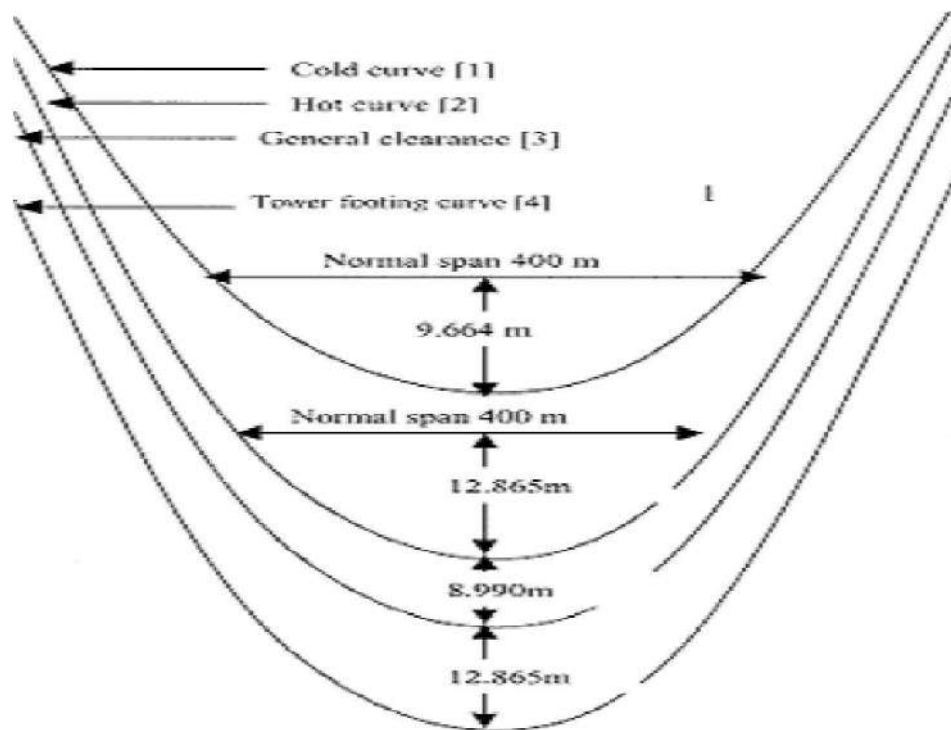

Fig 2.8- Sag Template

A Sag Template is specific for the particular line voltage, the conductor used and the applicable design conditions. Therefore, the correct applicable Sag Template should be used. A Sag Template consists of a set of parabolic curves drawn on a transparent celluloid or a crylic clear sheet duly cut in over the maximum conductor sag curve to allow the conductor curve to be drawn and the lowest points of the conductor sag to be marked on the profile when the profile is placed underneath it.

The set of curves in the sag template consists of:

- a) Cold or Uplift Curve' showing sag of conductor at minimum temperature (minus 2.5°C) and still wind.
- b) Hot or Maximum Sag Curve' showing maximum sag of conductor at maximum temperature and still wind including sag tolerances allowed (normally 4%), if any, and under maximum ice condition wherever applicable.
- c) Ground Clearance Curve' which is drawn parallel to the 'Hot or Maximum Sag Curve' and at a distance equal to the specified minimum ground clearance for the relevant voltage.
- d) 'Tower Footing Curve' which is drawn parallel to the 'Ground Clearance Curve' and separated by a minimum distance equal to the maximum sag at the basic design span.

### IMPORTANT CONSIDERATION IN MECHANICAL DESIGN

Mechanical factors of safety to be used in transmission line design should depend to some extent on the importance of continuity of operation in the line under consideration. In general, the strength of the line should be such as to provide against the worst probable weather conditions. We now discuss some important points in the mechanical design of overhead transmission lines.

**Tower height:** Tower height depends upon the length of span. With long spans, relatively few towers are required but they must be tall and correspondingly costly. It is not usually possible to determine the tower height and span length on the basis of direct construction costs because the lightning hazards increase greatly as the height of the conductors above ground is increased. This is one reason that horizontal spacing is favored in spite of the wider right of way required.

**Conductor clearance to ground:** The conductor clearance to ground at the time of greatest sag should not be less than some specified distance (usually between 6 and 12 m), depending on the voltage, on the nature of the country and on the local laws. The greatest sag may occur on the hottest day of summer on account of the expansion of the wire or it may occur in winter owing to the formation of a heavy coating of ice on the wires. Special provisions must be made for melting ice from the power lines.

**Sag and tension:** When laying overhead transmission lines, it is necessary to allow a reasonable factor of safety in respect of the tension to which the conductor is subjected. The tension is governed by the effects of wind, ice loading and temperature variations. The relationship between tension and sag is dependent on the loading conditions and temperature variations. For example, the tension increases when the temperature decreases and there is a corresponding decrease in the sag. Icing-up of the line and wind loading will cause stretching of the conductor by an amount dependent on the line tension.

In planning the sag, tension and clearance to ground of a given span, a maximum stress is selected. It is then aimed to have this stress developed at the worst probable weather conditions (i.e. minimum expected temperature, maximum ice loading and maximum wind). Wind loading increases the sag in the direction of resultant loading but decreases the vertical component. Therefore, in clearance calculations, the effect of wind should not be included unless horizontal clearance is important.

**Conductor spacing:** Spacing of conductors should be such so as to provide safety against flash-over when the wires are swinging in the wind. The proper spacing is a function of span length, voltage and weather conditions. The use of horizontal spacing eliminates the danger caused by unequal ice loading. Small wires or wires of light material are subjected to more swinging by the wind than heavy conductors. Therefore, light wires should be given greater spacing.

**Conductor vibration:** Wind exerts pressure on the exposed surface of the conductor. If the wind velocity is small, the swinging of conductors is harmless provided the clearance is sufficiently large so that conductors do not approach within the sparking distance of each other. A completely different type of vibration, called dancing, is caused by the action of fairly strong wind on a wire covered with ice, when the ice coating happens to take a form which makes a good air-foil section. Then the whole span may sail up like a kite until it reaches the limit of its slack, stops with a jerk and falls or sails back. The harmful effects of these vibrations occur at the clamps or supports where the conductor suffers fatigue and breaks eventually. In order to protect the conductors, Vibration Dampers are used.

## INSULATORS

**Electrical Insulator** must be used in electrical system to prevent unwanted flow of current to the earth from its supporting points. The **insulator** plays a vital role in electrical system. **Electrical Insulator** is a very high resistive path through which practically no current can flow. In transmission and distribution system, the overhead conductors are generally supported by supporting towers or poles. The towers and poles both are properly grounded. So there must

be **insulator** between tower or pole body and current carrying conductors to prevent the flow of current from conductor to earth through the grounded supporting towers or poles.

### **Insulating Material**

The main cause of failure of overhead line insulator, is flash over, occurs in between line and earth during abnormal over voltage in the system. During this flash over, the huge heat produced by arcing, causes puncher in insulator body. Viewing this phenomenon the materials used for electrical insulator, has to posses some specific properties.

### **Properties of Insulating Material**

The materials generally used for insulating purpose is called **insulating material**. For successful utilization, this material should have some specific properties as listed below-

- High mechanical strength in order to withstand conductor load, wind load etc.
- High electrical resistance of insulator material in order to avoid leakage currents to earth.
- High relative permittivity of insulator material in order that dielectric strength is high.
- The insulator material should be non-porous, free from impurities and cracks otherwise the permittivity will be lowered.
- High ratio of puncture strength to flashover.

The most commonly used material for insulators of overhead line is porcelain but glass, steatite and special composition materials are also used to a limited extent. Porcelain is produced by firing at a high temperature a mixture of kaolin, feldspar and quartz. It is stronger mechanically than glass, gives less trouble from leakage and is less affected by changes of temperature. The successful operation of an overhead line depends to a considerable extent upon the proper selection of insulators.

There are three types of insulators used in connection with overhead lines. They are:

- Pin-type.
- Suspension-type.
- Strain-type.

### PIN-TYPE INSULATORS

As the name suggests, the pin-type insulator shown in Fig.-5.1 is attached to a steel bolt or pin, which is secured to a cross-arm on the transmission pole.

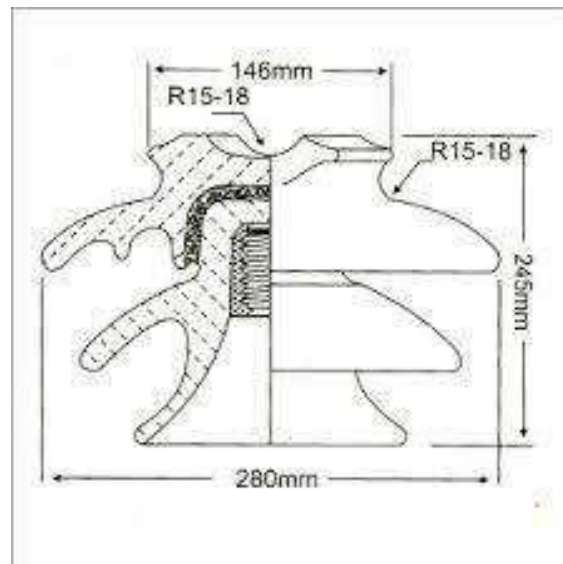

FIG.-5.1 PIN TYPE INSULATORS

The Standards Specification requires that the porcelain shall not engage directly with a hard metal screw. It recognizes two methods:

- The provision of a taper thread cut on the head of the pin, which screws into a threaded soft metal thimble cemented into the insulator.
- The provisions of a cast lead thread on the steel spindle, which screws directly into a thread formed in the porcelain; on the continent the pin, which has a plain top, is still sometimes wrapped in hemp and the threaded porcelain screwed on.

For operating voltages up to about 11 kV with ordinary designs of insulator a one-piece construction can be adopted. Recent progress in design and manufacture has enabled much

thicker sections to be adopted, with the result that for working voltages up to 33 kV a single-piece construction is possible, and not more than two parts even in the largest sizes. Actually, the tendency is to use pin-type insulators for voltages up to 33 kV only, since they become uneconomical for higher voltages. This is because their cost increases much more rapidly than the voltage.

There should be sufficient thickness of porcelain between the line conductor and the insulator pin (or other metal work) to give a factor of safety of up to 10 against puncture, but the insulator should be designed so that it will spark-over before it will puncture. The ratio of the spark-over voltage to the working voltage is called the safety factor, and for pin-type insulators this factor is much higher for low voltages than it is for high. The present tendency is to use pin-type insulators for low voltages only, say up to 11 kV, for which the factors of safety are 8.3 dry and 5 wet. With a wet insulator, the surfaces of the various pieces, or 'sheds' as they are sometimes called, have no insulating value, so that the total arcing distance is the sum of the shortest distances from the edge of one shed to the nearest point on the next lower shed, plus the distance from the edge of the next lowest shed to the pin.

The insulator and its pin, or other support, should be sufficiently strong mechanically to withstand the resultant force due to the combined effects of wind pressure and weight of span (and ice load, if any). At terminal poles there is, in addition, the almost horizontal pull due to the tension of the conductor. This, in particular, causes such a great bending moment at the bottom of the pin, with pin-type insulators, this being transmitted to the cross-arm, that for a line insulated with pin-type insulators, it is desirable to use some type of strain insulator at all terminal or dead-ending poles. In connection with the mechanical strength, it is to be noted that the insulator is stronger than the pin.

### **SUSPENSION INSULATORS**

We have seen that the cost of a pin-type insulator increases very rapidly as the working voltage is increased. For high voltages this type is therefore uneconomical, and there is the further disadvantage that replacements are expensive. For these reasons, high-voltage lines are insulated by means of suspension insulators in which, as their name indicates, the line conductor is suspended below the point of support by means of the insulator or insulators. Several important advantages follow from this system.

- Each insulator is designed for a comparatively low working voltage, usually about 11 kV, and the insulation for any required line voltage can be obtained by using a 'string' of a suitable number of such insulators.
- In the event of a failure of an insulator, one unit - instead of the whole string - has to be replaced.
- The mechanical stresses are reduced,

since the line is suspended flexibly; with pin- type insulators, the rigid nature of the attachment results in fatigue and ultimate brittleness of the wire, due to the alternating nature of the stress. Also, since the string is free to swing, there is an equalization of the tensions in the conductors of successive spans.

- In the event of an increase in the operating voltage of the line, this can be met by adding the requisite number of units to each string, instead of replacing all insulators, as would be necessary with pin-type.
- Owing to the free suspension, the amplitude of swing of the conductors may be large compared with that on a pin-type insulated line, and the spacing should therefore be increased.

There are several types of suspension insulator that illustrated in Fig.-5.2 being most frequently used in this country, having been adopted for the insulation of the Grid lines. It will be seen that it consists of a single disc-shaped piece of porcelain, grooved on the under-surface to increase the surface leakage path, and to a metal cap at the top, and to a metal pin underneath. The cap is recessed so as to take the pin of another unit, and in this way a string of any required number of units can be built up. The cap is secured to the insulator by means of cement. Various means of securing the pin have been tried, but all have been abandoned in favor of cementing. Mechanical methods of fixing have proved unsatisfactory since they caused concentrations of mechanical stress, which led to failure in service. On the other hand, cement acts as a good distributor of mechanical stress, and cemented insulators of good mechanical design have an excellent service record.

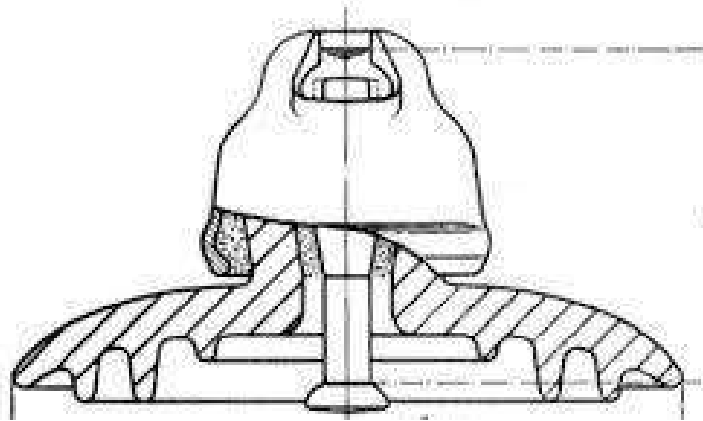
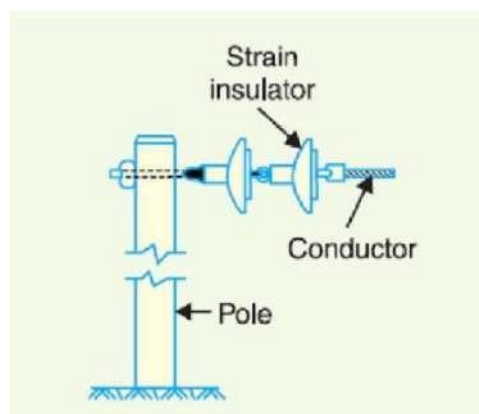

FIG.-5.2 SUSPENSION TYPE INSULATORS

The usual diameter of this type of insulator is ten inches, since it has been found that this size gives a suitable ratio of spark-over to puncture voltage. Increasing the diameter raises the spark-over voltage, of course, but it also lowers the above ratio, and this is undesirable.

### STRAIN INSULATORS

These insulators are used to take the tension of the conductors at line terminals and at points where the line is dead-ended, as for example some road-crossings, junctions of overhead lines with cables, river crossings, at angle towers where there is a change in direction of the line, and so on. For light low-voltage lines, say up to 11 kV, the shackle insulator is suitable, but for higher voltages a string of suspension-type insulators is necessary. Where the tension is exceedingly high, as at long river spans, two, three, or even four strings of insulators in parallel have been used.



## SHACKLE INSULATOR OR SPOOL INSULATOR

The **shackle insulator** or **spool insulator** is usually used in low voltage distribution network. It can be used both in horizontal and vertical position. The use of such insulator has decreased recently after increasing the using of underground cable for distribution purpose. The tapered hole of the **spool insulator** distributes the load more evenly and minimizes the possibility of breakage when heavily loaded. The conductor in the groove of **shackle insulator** is fixed with the help of soft binding wire.

## POTENTIAL DISTRIBUTION OVER A STRING OF SUSPENSION INSULATORS:

A string of suspension insulators consists of a number of porcelain discs connected in series through metallic links. Fig. 2.3(i) shows 3-disc string of suspension insulators. The porcelain portion of each disc is in between two metal links. Therefore, each disc forms a capacitor  $C$  as shown in Fig.2.3 (ii). This is known as mutual capacitance or self-capacitance. If there were mutual capacitance alone, then charging current would have been the same through all the discs and consequently voltage across each unit would have been the same i.e.,  $V/3$  as shown in Fig. 2.3(ii). However, in actual practice, capacitance also exists between metal fitting of each disc and tower or earth. This is known as shunt capacitance  $C_1$ . Due to shunt capacitance, charging current is not the same through all the discs of the string [See Fig 2.3(iii)]. Therefore, voltage across each disc will be different. Obviously, the disc nearest to the line conductor will have the maximum voltage. Thus referring to Fig 2.3(iii),  $V_3$  will be much more than  $V_2$  or  $V_1$ .

The following points may be noted regarding the potential distribution over a string of suspension insulators:

- (i) The voltage impressed on a string of suspension insulators does not distribute itself uniformly across the individual discs due to the presence of shunt capacitance.
- (ii) The disc nearest to the conductor has maximum voltage across it. As we move towards the cross-arm, the voltage across each disc goes on decreasing.
- (iii) The unit nearest to the conductor is under maximum electrical stress and is likely to be punctured. Therefore, means must be provided to equalize the potential across each unit.
- (iv) The presence of stray capacitance causes unequal potential distribution over the string. The end unit of the string (which is the closest to the line) takes maximum potential difference and the upper units have a gradually decreased potential difference until the uppermost unit which has the lowest potential difference. The next proof illustrates this concept.

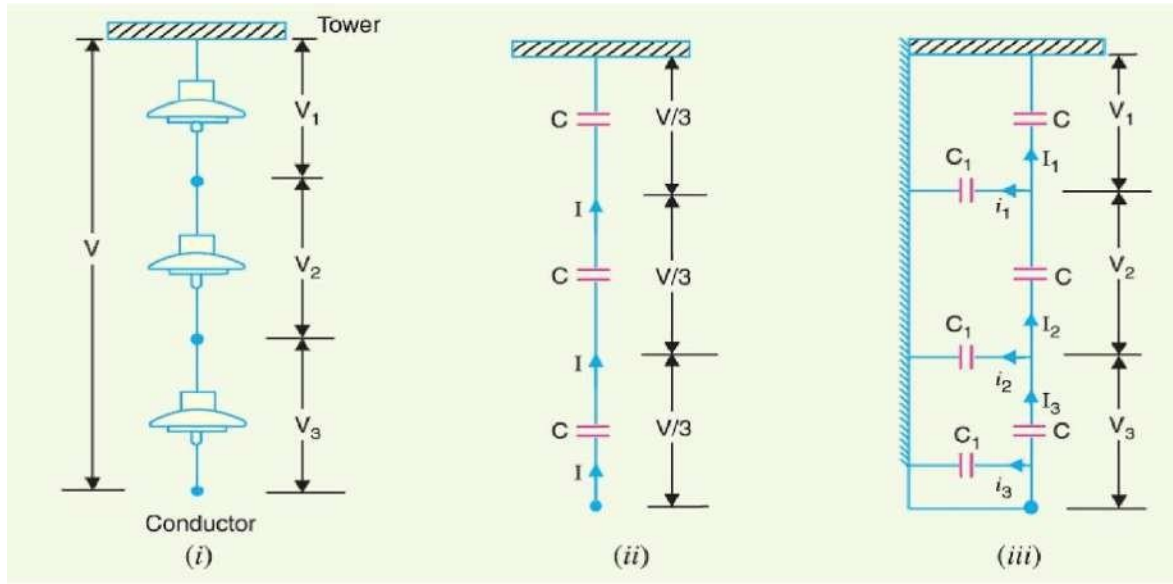

Fig 2.3- Suspension Insulator string

### STRING EFFICIENCY:

As stated above, the voltage applied across the string of suspension insulators is not uniformly distributed across various units or discs. The disc nearest to the conductor has much higher potential than the other discs. This unequal potential distribution is undesirable and is usually expressed in terms of string efficiency.

The ratio of voltage across the whole string to the product of number of discs and the voltage across the disc nearest to the conductor is known as string efficiency i.e.

$$\eta_{string} = \frac{\text{Voltage across string}}{\text{No. of Insulators X Voltage across the Insulator adjacent to the conductor}} \quad (5.8)$$

Where n is the no. of discs in the string.

String efficiency is an important consideration since it decides the potential distribution along the string. The greater the string efficiency, the more uniform is the voltage distribution. Thus 100% string efficiency is an ideal case for which the voltage across each disc will be exactly the same. Although it is impossible to achieve 100% string efficiency, yet efforts should be made to improve it as close to this value as possible.

**MATHEMATICAL EXPRESSION.**

Fig. 2.3(iii) shows the equivalent circuit for a 3-disc string. Let us suppose that self capacitance of each disc is C. Let us further assume that shunt capacitance C1 is some fraction K of self capacitance i.e.,  $C_1 = KC$ . Starting from the cross-arm or tower, the voltage across each unit is  $V_1, V_2$  and  $V_3$  respectively as shown.

Applying kirchoff's current law to node A

$$I_2 = I_1 + i_1$$

$$V_2 \omega C = V_1 \omega C + V_1 \omega C_1$$

$$V_2 \omega C = V_1 \omega C + V_1 \omega KC$$

$$V_2 = V_1(1 + K)$$

Applying kirchoff's current law to node B

$$I_3 = I_2 + i_2$$

$$V_3 \omega C = V_2 \omega C + (V_1 + V_2) \omega C_1$$

$$V_3 \omega C = V_2 \omega C + (V_1 + V_2) \omega KC$$

$$V_3 = KV_1 + V_2(1 + K)$$

$$V_3 = V_1(1 + 3K + K^2)$$

$$\%stringefficiency = \frac{V}{3 \times V_3} \times 100$$

The following points may be noted from the above mathematical analysis:

- (i) If  $K = 0.2$  (Say), then we get,  $V_2 = 1.2 V_1$  and  $V_3 = 1.64 V_1$ . This clearly shows that disc nearest to the conductor has maximum voltage across it; the voltage across other discs decreasing progressively as the cross-arm is approached.
- (ii) The greater the value of  $K (= C1/C)$ , the more non-uniform is the potential across the discs and lesser is the string efficiency.
- (iii) The inequality in voltage distribution increases with the increase of number of discs in the string. Therefore, shorter string has more efficiency than the larger one

### **STRING EFFICIENCY AND METHODS TO IMPROVE STRING EFFICIENCY**

The ratio of voltage across the whole string to the product of number of discs and the voltage across the disc nearest to the conductor is known as string efficiency i.e.,

$$\eta_{string} = \frac{\text{Voltage across string}}{\text{No. of Insulators X Voltage across the Insulator adjacent to the conductor}} \quad (5.8)$$

where  $n =$  number of discs in the string.

String efficiency is an important consideration since it decides the potential distribution along the string. The greater the string efficiency, the more uniform is the voltage distribution. Thus 100% string efficiency is an ideal case for which the voltage across each disc will be exactly the same. Although it is impossible to achieve 100% string efficiency, yet efforts should be made to improve it as close to this value as possible.

### VOLTAGE DISTRIBUTION IN A STRING OF INSULATOR

Let us consider a string consists of four insulators as shown in Fig.-5.3 operating at voltage

' $V$ ' (Line to Ground). Each insulator is represented by its capacitor.

' $C$ '-The capacitance of each insulator

' $KC$ ' -The capacitance of insulator pin to ground

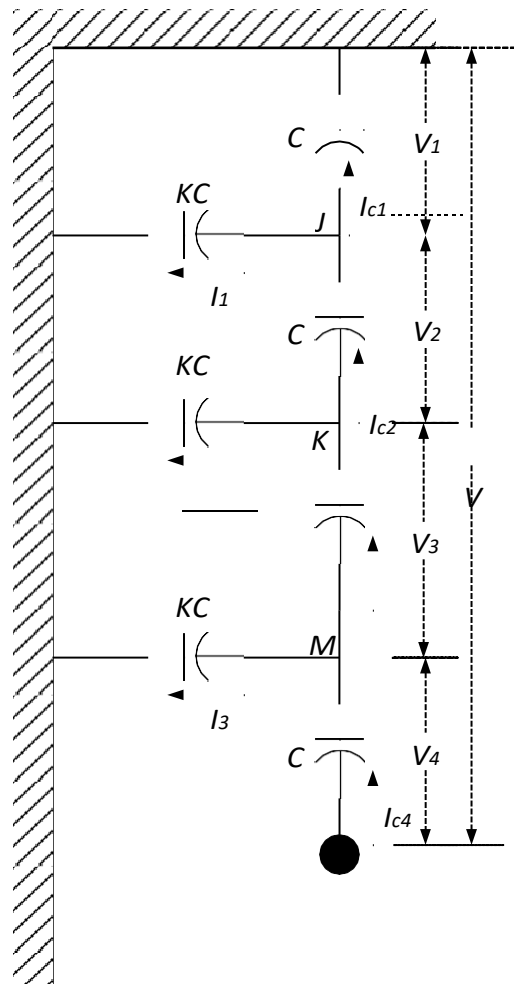

FIG.-5.3 STRING OF FOUR INSULATORS

At node 'J' using KCL we can write

$$I_{c2} = I_{c1} + I_1 \quad (5.1a)$$

$$\omega CV_2 = \omega CV_1 + \omega KC V_1 \quad (5.1b)$$

Which can be simplified to (5.2)

$$V_2 = (1 + K)V_1 \quad (5.2)$$

At node 'K' using KCL we can write

$$I_{c3} = I_{c2} + I_2 \quad (5.3a)$$

$$\omega CV_3 = \omega CV_2 + \omega KC(V_1 + V_2) \quad (5.3b)$$

Which can be simplified to (5.4) by using (5.2)

$$V_3 = (1 + 3K + K^2)V_1 \quad (5.4)$$

At node 'M' using KCL we can write

$$I_{c4} = I_{c3} + I_3 \quad (5.5a)$$

$$\omega CV_4 = \omega CV_3 + \omega KC(V_1 + V_2 + V_3) \quad (5.5b)$$

Which can be simplified to (5.6) by using (5.2) and (5.4)

$$V_4 = (1 + 6K + 5K^2 + K^3)V_1 \quad (5.6)$$

For the whole string we have

$$V = V_1 + V_2 + V_3 + V_4 \quad (5.7)$$

Using the above equations we can determine the voltage across each insulator and it can be seen that they are not equal i.e. voltage distribution in the string is not uniform. At this point let us define string efficiency as follows:

$$\eta_{string} = \frac{\text{Voltage across string}}{\text{No. of Insulators X Voltage across the Insulator adjacent to the conductor}} \quad (5.8)$$

This efficiency is very low because of unequal voltage distribution. It can be increased by the following methods which is also known as grading of the insulators.

## METHODS OF IMPROVING STRING EFFICIENCY

### LENGTH OF THE CROSS ARM

As we can see the voltage distribution depends largely on the value of 'K'. Hence if the value of 'K' is reduced the distribution can be made equal and string efficiency can be improved.

It can be done by increasing the length of the cross arm. However there is limitation to it because of mechanical strength of the supporting tower.

### GRADING OF INSULATORS UNITS

It is observed from the above derivation that the insulators having same capacitors have been used in the string. To make voltage distribution equal we can use insulators having different capacitance as shown in Fig.-5.4 such that we will result in the following

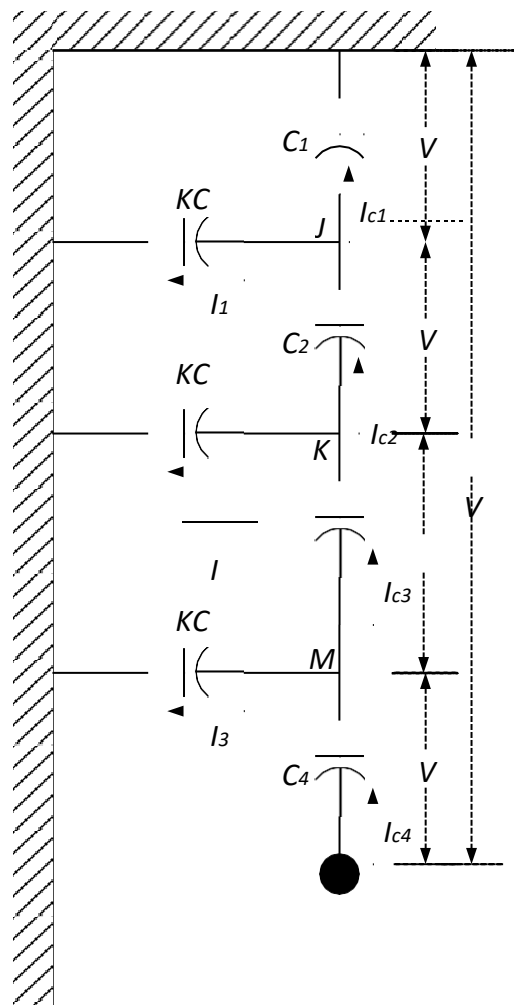

FIG.-5.4 GRADING OF STRING OF FOUR INSULATORS

$$I_{c2} = I_{c1} + I_1 \tag{5.9a}$$

$$\omega C_2 V = \omega C_1 V + \omega K C_1 V \tag{5.9b}$$

Which can be simplified to (5.10)

$$C_2 = (1 + K) C_1 \tag{5.10}$$

Similarly we can use for the other nodes and can determine the capacitor of each insulators of the string. However this method is not practically feasible because of large no. of insulators in the string for very high voltage transmission line.

**STATIC SHIELDING (GUARD RING)**

The voltage distribution can also be equalized by using static shielding. The basic objective is provide the charging current flowing through the capacitance between insulator pin and the ground by another alternate path. So that the current flowing in each insulator shall be equal and hence the voltage across each insulator shall be equal as shown in Fig.-5.5.

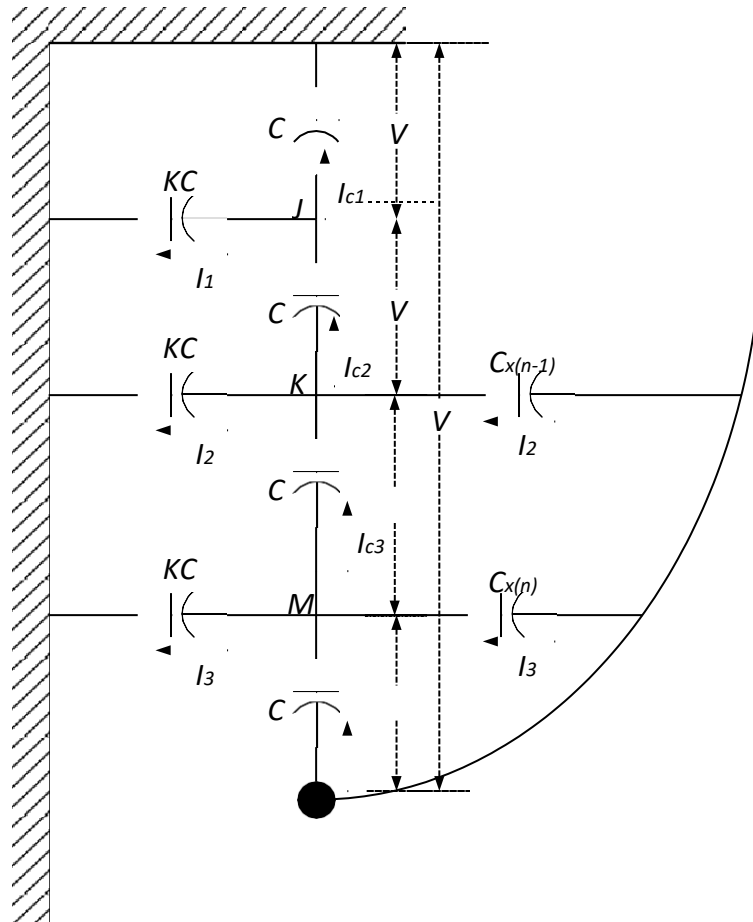

**FIG.-5.5 STATIC SHIELDING OF STRING OF FOUR INSULATORS****TESTING OF INSULATORS**

The testing of insulators are made into three categories: flash-over tests, sample tests, and routine tests. In each category, there is a group of individual tests. Flash-over tests are a design test

taken to three insulators only to prove the correction of the design; sample tests are to prove the quality of manufacture, and are taken on 1/2 per cent. of the insulators supplied; routine tests are carried out on all insulators.

**Flashover Tests**

- 50 per cent. dry impulse flash-over test.
- Dry flash-over and dry one-minute test.
- Wet flash-over and one-minute rain test. Sample Tests
- Temperature-cycle test.
- Mechanical test.
- Electro-mechanical test.
- Puncture test.
- Porosity test.

**Routine Tests**

- Electrical routine test.
- Mechanical routine test.

The details methodology of these tests can be referred from Bureau of Indian Standard.

## **UNIT -II**

### **UNDERGROUND CABLES**

#### **INSULATED CABLES**

Electric power can be transmitted or distributed either by overhead system or by underground cables. The underground cables have several advantages such as less liable to damage through storms or lightning, low maintenance cost, less chance of faults, smaller voltage drop and better general appearance. However, their major drawback is that they have greater installation cost and introduce insulation problems at high voltages compared with the equivalent overhead system. For this reason, underground cables are employed where it is impracticable to use overhead lines. Such locations may be thickly populated areas where municipal authorities prohibit overhead lines for reasons of safety, or around plants and substations or where maintenance conditions do not permit the use of overhead construction. The chief use of underground cables for many years has been for distribution of electric power in congested urban areas at comparatively low or moderate voltages. However, recent improvements in the design and manufacture have led to the development of cables suitable for use at high voltages. This has made it possible to employ underground cables for transmission of electric power for short or moderate distances. In this chapter, we shall focus our attention on the various aspects of underground cables and their increasing use in power system.

#### **UNDERGROUND CABLES:-**

An underground cable essentially consists of one or more conductors covered with suitable insulation and surrounded by a protecting cover. Although several types of cables are available, the type of cable to be used will depend upon the working voltage and service requirements. In general, a cable must fulfill the following necessary requirements:

- (i) The conductor used in cables should be tinned stranded copper or aluminum of high conductivity. Stranding is done so that conductor may become flexible and carry more current.
- (ii) The conductor size should be such that the cable carries the desired load current without overheating and causes voltage drop within permissible limits.
- (iii) The cable must have proper thickness of insulation in order to give high degree of safety and reliability at the voltage for which it is designed.
- (iv) The cable must be provided with suitable mechanical protection so that it may withstand the rough use in laying it.
- (v) The materials used in the manufacture of cables should be such that there is complete chemical and physical stability throughout.

**CONSTRUCTION OF CABLES:**

Fig 2.9- Cable

Figure shows the general construction of a 3-conductor cable. The various parts are

(i) **Cores or Conductors.** A cable may have one or more than one core (conductor) depending upon the type of service for which it is intended. For instance, the 3 conductor cable shown in Figure is used for 3-phase service. The conductors are made of tinned copper or aluminum and are usually stranded in order to provide flexibility to the cable.

(ii) **Insulation.** Each core or conductor is provided with a suitable thickness of insulation, the thickness of layer depending upon the voltage to be withstood by the cable. The commonly used materials for insulation are impregnated paper, varnished cambric or rubber mineral compound.

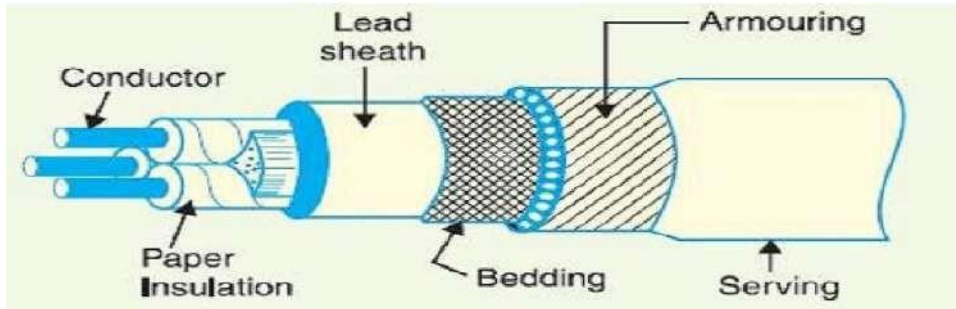
(iii) **Metallic sheath.** In order to protect the cable from moisture, gases or other damaging liquids (acids or alkalies) in the soil and atmosphere, a metallic sheath of lead or aluminum is provided over the insulation as shown in Fig.

(iv) **Bedding.** Over the metallic sheath is applied a layer of bedding which consists of a fibrous material like jute or hessian tape. The purpose of bedding is to protect the metallic sheath against corrosion and from mechanical injury due to armouring.

(v) **Armouring.** Over the bedding, armouring is provided which consists of one or two layers of galvanized steel wire or steel tape. Its purpose is to protect the cable from mechanical injury while laying it and during the course of handling. Armouring may not be done in the case of some cables.

(vi) **Serving.** In order to protect armouring from atmospheric conditions, a layer of fibrous material (like jute) similar to bedding is provided over the armouring. This is known as serving.

It may not be out of place to mention here that bedding, armouring and serving are only applied to the cables for the protection of conductor insulation and to protect the metallic sheath from mechanical injury.

**Insulating Materials for Cables:-**The satisfactory operation of a cable depends to a great extent upon the characteristics of insulation used. Therefore, the proper choice of insulating material for cables is of considerable importance.

**In general, the insulating materials used in cables should have the following properties:**

- (i) High insulation resistance to avoid leakage current.
- (ii) High dielectric strength to avoid electrical breakdown of the cable.
- (iii) High mechanical strength to withstand the mechanical handling of cables.
- (iv) Non-hygroscopic i.e., it should not absorb moisture from air or soil. The moisture tends to decrease the insulation resistance and hastens the breakdown of the cable. In case the insulating material is hygroscopic, it must be enclosed in a waterproof covering like lead sheath.
- (v) Non-inflammable.
- (vi) Low cost so as to make the underground system a viable proposition.
- (vii) Unaffected by acids and alkalis to avoid any chemical action. No one insulating material possesses all the above mentioned properties. Therefore, the type of insulating material to be used depends upon the purpose for which the cable is required and the quality of insulation to be aimed at.

The principal insulating materials used in cables are rubber, vulcanized rubber, impregnated paper and polyvinyl chloride.

**1. Rubber:** Rubber may be obtained from milky sap of tropical trees or it may be produced from oil products. It has relative permittivity varying between 2 and 3, dielectric strength is about 30 kV/mm and resistivity of insulation is 10<sup>17</sup> cm. Although pure rubber has reasonably high insulating properties, it suffers from some major drawbacks viz., readily absorbs moisture, maximum safe temperature is low (about 38°C), soft and liable to damage due to rough handling and ages when exposed to light. Therefore, pure rubber cannot be used as an insulating material.

**2. Vulcanised India Rubber (V.I.R.).** It is prepared by mixing pure rubber with mineral matter such as zinc oxide, red lead etc., and 3 to 5% of sulphur. The compound so formed is rolled into thin sheets and cut into strips. The rubber compound is then applied to the conductor and is heated to a temperature of about 150°C. The whole process is called vulcanisation and the product obtained is known as vulcanised India rubber. Vulcanised India rubber has greater mechanical strength, durability and wear resistant property than pure rubber. Its main drawback is that sulphur reacts very quickly with copper and for this reason, cables using VIR insulation have tinned copper conductor. The VIR insulation is generally used for low and moderate voltage cables.

**3. Impregnated paper.** It consists of chemically pulped paper made from wood chippings and impregnated with some compound such as paraffinic or naphthenic material. This type of insulation has almost superseded the rubber insulation. It is because it has the advantages of low cost, low capacitance, high dielectric strength and high insulation resistance. The only disadvantage is that paper is hygroscopic and even if it is impregnated with suitable compound, it absorbs moisture and thus lowers the insulation resistance of the cable.

**4. Polyvinyl chloride (PVC).** This insulating material is a synthetic compound. It is obtained from the polymerization of acetylene and is in the form of white powder. For obtaining this material as a cable insulation, it is compounded with certain materials known as plasticizers which are liquids with high boiling point. The plasticizer forms a gell and renders the material plastic over the desired range of temperature. Polyvinyl chloride has high insulation resistance, good dielectric strength and mechanical toughness over a wide range of temperatures. It is inert to oxygen and almost inert to many alkalies and acids. Therefore, this type of insulation is preferred over VIR in extreme environmental conditions such as in cement factory or chemical factory. As the mechanical properties (i.e., elasticity etc.) of PVC are not so good as those of rubber, therefore, PVC insulated cables are generally used for low and medium domestic lights and power installations.

#### CLASSIFICATION OF CABLES:

Cables for underground service may be classified in two ways according to

- (i) the type of insulating material used in their manufacture
- (ii) the voltage for which they are manufactured.

However, the latter method of classification is generally preferred, according to which cables can be divided into the following groups:

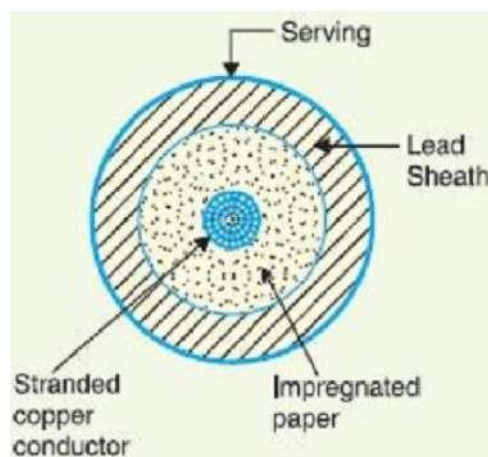

**Fig 2.10- Cross section of Cables**

- (i) Low-tension (L.T.) cables — upto 1000 V
- (ii) High-tension (H.T.) cables — upto 11,000 V
- (iii) Super-tension (S.T.) cables — from 22 kV to 33 kV (iv) Extra high-tension (E.H.T.) cables — from 33 kV to 66 kV
- (iv) Extra super voltage cables — beyond 132 kV

A cable may have one or more than one core depending upon the type of service for which it is intended. It may be

- (i) single-core
- (ii) two-core
- (iii) three-core
- (iv) four-core etc

For a 3-phase service, either 3-single-core cables or three-core cable can be used depending upon the operating voltage and load demand. Fig. 11.2 shows the constructional details of a single-core low tension cable. The cable has ordinary construction because the stresses developed in the cable for low voltages (up to 6600 V) are generally small. It consists of one circular core of tinned stranded copper (or aluminium) insulated by layers of impregnated paper. The insulation is surrounded by a lead sheath which prevents the entry of moisture into the inner parts. In order to protect the lead sheath from corrosion, an overall serving of compounded fibrous material (jute etc.) is provided. Single-core cables are not usually armoured in order to avoid excessive sheath losses. The principal advantages of single-core cables are simple construction and availability of larger copper section.

### **CABLE FOR 3-PHASE:**

In practice, underground cables are generally required to deliver 3-phase power. For the purpose, either three-core cable or three single core cables may be used. For voltages up to 66 kV, 3-core cable (i.e., multi-core construction) is preferred due to economic reasons. However, for voltages beyond 66 kV, 3-core-cables become too large and unwieldy and, therefore, single-core cables are used. The following types of cables are generally used for 3-phase service:

1. Belted cables — up to 11 kV
2. Screened cables — from 22 kV to 66 kV
3. Pressure cables — beyond 66 kV

### **DIELECTRIC STRESS IN CABLE:**

Under operating conditions, the insulation of a cable is subjected to electrostatic forces. This is known as dielectric stress. The dielectric stress at any point in a cable is in fact the potential gradient (or electric intensity) at that point. Consider a single core cable with core diameter  $d$  and internal sheath diameter  $D$ . The electric intensity at a point  $x$  metres from the centre of the cable is

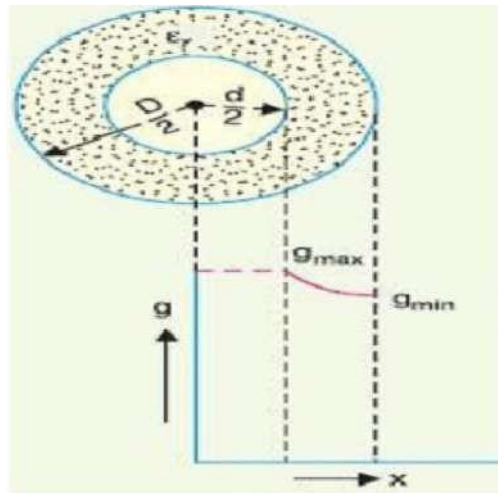

Fig 2.11- Dielectric Stress in Cable

$$E_x = \frac{Q}{2\pi\epsilon_0\epsilon_r x} \text{ volts/m}$$

By definition, electric intensity is equal to potential gradient. Therefore, potential gradient  $g$  at a point  $x$  meters from the Centre of cable is

$$g = E_x$$

$$g = \frac{E}{2\pi\epsilon_0\epsilon_r x} \text{ volts/m}$$

Potential difference  $V$  between conductor and sheath is

$$g_{\max} = \frac{2V}{d \ln \frac{D}{d}} \text{ volts/m}$$

Substituting the value of  $Q$ , we get It is clear from the above equation that potential gradient varies inversely as the distance  $x$ . Therefore, potential gradient will be maximum when  $x$  is minimum i.e., when  $x = d/2$  or at the surface of the conductor. On the other hand, potential gradient will be minimum at  $x = D/2$  or at sheath surface.

Maximum potential gradient is

$$g_{\max} = \frac{2V}{d \ln \frac{D}{d}} \text{ volts/m}$$

Minimum potential gradient is

$$g_{\min} = \frac{2V}{D \ln \frac{D}{d}} \text{ volts/m}$$

$$\frac{g_{\max}}{g_{\min}} = \frac{D}{d}$$

The variation of stress in the dielectric is shown in Fig.14. It is clear that dielectric stress is maximum at the conductor surface and its value goes on decreasing as we move away from the conductor. It may be noted that maximum stress is an important consideration in the design of a cable. For instance, if a cable is to be operated at such a voltage that maximum stress is 5 kV/mm, then the insulation used must have a dielectric strength of at least 5 kV/mm, otherwise breakdown of the cable will become inevitable.

### CAPACITANCE IN A SINGLE-CORE CABLE

Let us consider a single core cable as shown in Fig.-7.2.

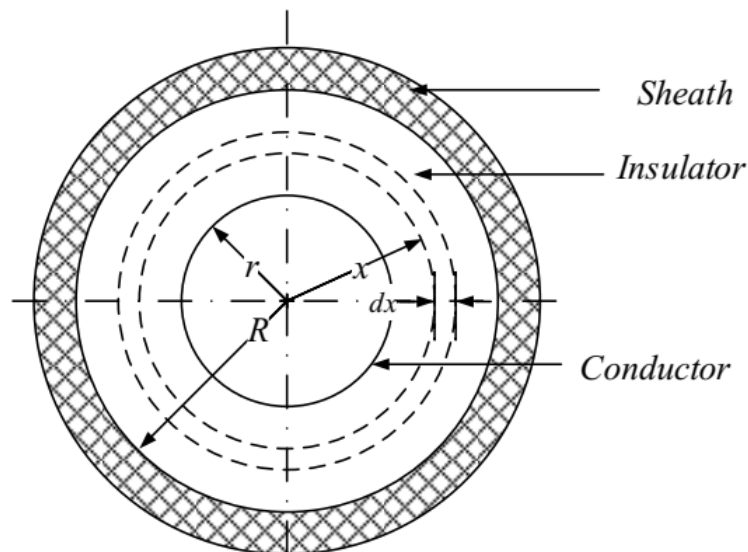

FIG.-7.2 CAPACITANCE CALCULATION OF SINGLE PHASE CABLE

Where,

$r$  = radius of core ( $m$ )

$R$  = inner radius of earthed sheath ( $m$ )

$q$  = charge/unit length of cable ( $C/m$ )

$D$  = electric flux density = charge density ( $C/m^2$ )

$k$  = permittivity of free space

Let us consider an elemental cylinder of radius  $x$  and thickness  $dx$ , and of length unity along the cable.

$$g = \frac{q}{2\pi kx} \text{ (V/m)} \quad (7.1)$$

$$V = \int_r^R g dx = \frac{q}{2\pi k} \ln\left(\frac{R}{r}\right) \quad (7.2)$$

Hence from (7.1) and (7.2) we obtain

$$g = \frac{V}{x \ln\left(\frac{R}{r}\right)} \quad (7.3a)$$

The electrical stress shall be maximum at the surface of the conductor i.e. at  $x = r$  and minimum at the inner surface of the sheath i.e.  $x = R$ . So that we can write:

$$g_{\max} = \frac{V}{r \ln\left(\frac{R}{r}\right)} \quad (7.3b)$$

$$g_{\min} = \frac{V}{R \ln\left(\frac{R}{r}\right)} \quad (7.3c)$$

The maximum stress should be minimum so that the cable can work satisfactorily without rupturing the insulation. To achieve this we can differentiate (7.3b) w.r.t.  $r$  and make it equal to zero.

$$\frac{dg_{\max}}{dr} = \frac{d}{dr} \left( \frac{V}{r \ln \left( \frac{R}{r} \right)} \right) = 0 \quad (7.3d)$$

Solving (7.3b) we get

$$\frac{R}{r} = e = 2.718 \quad (7.3e)$$

Thus if the overall diameter of the cable is kept fixed, then  $R/r = e$  is the condition for minimum  $g_{\max}$ . This value of radius of conductor will generally be larger than would be required for current carrying capacity. Since the radius of the conductor that would be given from the above expression is larger than is necessary for current carrying capacity, this value of radius may be achieved by using aluminum or hollow conductors.

The stress can be written as

$$g = \frac{q}{2\pi kx} = \frac{q}{2\pi k_0 k_r x} = \frac{18 \times 10^9 q}{k_r x} \quad (\text{V/m}) \quad (7.4)$$

The capacitance of the cable is then given by

$$C = \frac{q}{V} = \frac{k_r}{18 \times 10^9 \ln \left( \frac{R}{r} \right)} \quad (\text{F/m}) \quad (7.5)$$

$$C = \frac{0.024 k_r}{\ln \left( \frac{R}{r} \right)} \quad (\mu\text{F/km}) \quad (7.6)$$

### CAPACITANCE OF THREE-CORE BELTED TYPE CABLES

In the case of a 3-core cable as shown in Fig.7.3, the 3-cores are individually insulated with paper insulation. The filler spaces between the core insulation is also filled up with insulation, but depriving these of voids is much more difficult. Belt insulation is used on top of all three core insulations, and the lead sheath is extruded over this. Over the lead sheath, there is generally bitumen to prevent damage. In buried cables, additional protection is necessary to prevent damage. There are two types of armouring used for these cables.

- Steel tape armouring - the steel tape is usually wound in two layers with opposite directions of lay
- Steel wire armouring - the steel wires are laid in one or two layers.

The capacitance between the conductors to neutral of 3-core belted cables cannot be obtained by a simple derivation as for the single core cable. Simon's expression can be used to obtain this value. The capacitance per unit length to neutral is given by

$$C = \frac{0.03k_r}{\log_{10} \left[ \left( 0.52 \left( \frac{t}{T} \right)^2 - 1.7 \left( \frac{t}{T} \right) + 3.84 \right) \left( \frac{T+t}{d} \right) + 1 \right]} \quad (\mu\text{F/km}) \quad (7.7)$$

Where,

$t$  = thickness of belt insulation

$T$  = thickness of conductor insulation

$d$  = diameter of conductor

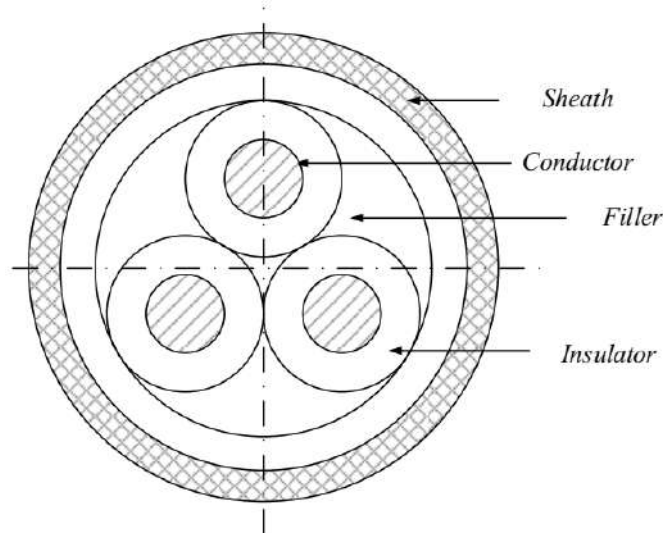

FIG.-7.3 THREE-CORE BELTED TYPE CABLES

### MEASUREMENT OF CAPACITANCE OF 3-CORE CABLES

In three-core cables, capacitance does not have a single value, but can be lumped as shown in Fig.-7.4.

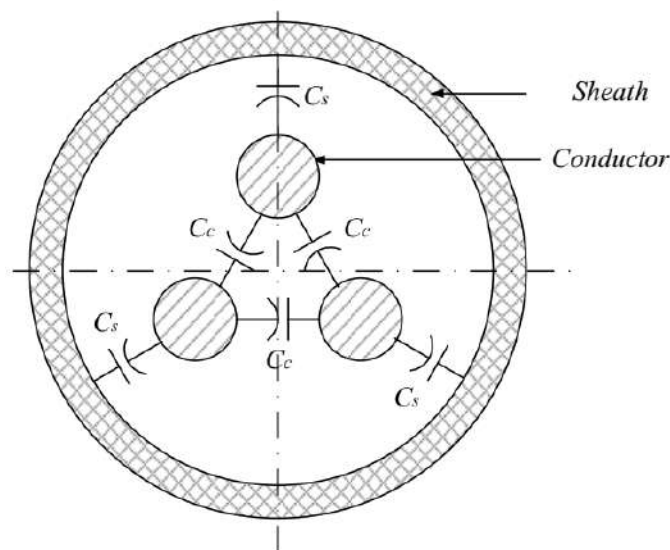

FIG.-7.4 CAPACITANCE OF 3-CORE CABLES

Where,  $C_s$  - Capacitance between each core and sheath and  $C_c$  - Capacitance between cores  
These can be calculated as mentioned below:

**Step-I:** Strap the 3 cores together and measure the capacitance between this bundle and the sheath as shown in Fig.-7.5. Let this value to be  $C_x$ , So that

$$C_x = 3C_s \quad (7.8)$$

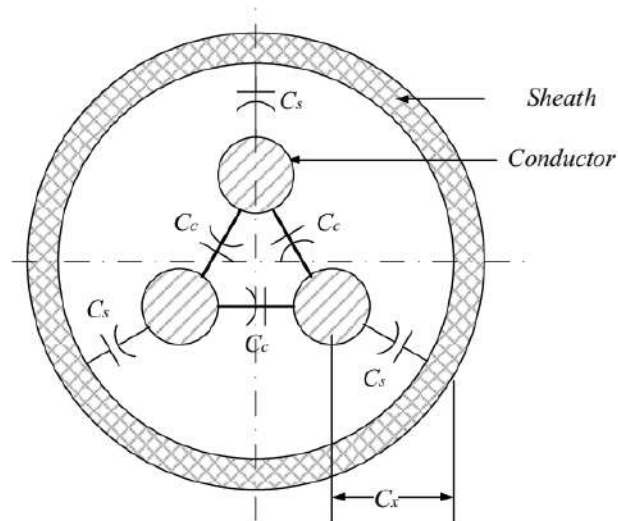

FIG.-7.5 MEASUREMENT OF CAPACITANCE OF 3-CORE CABLES (STEP-I)

**Step-II:** Connect 2 of the cores to the sheath and measure between the remaining core and the sheath as shown in Fig.-7.6. Let this value to be  $C_y$ , So that

$$C_y = C_s + 2C_c \quad (7.9)$$

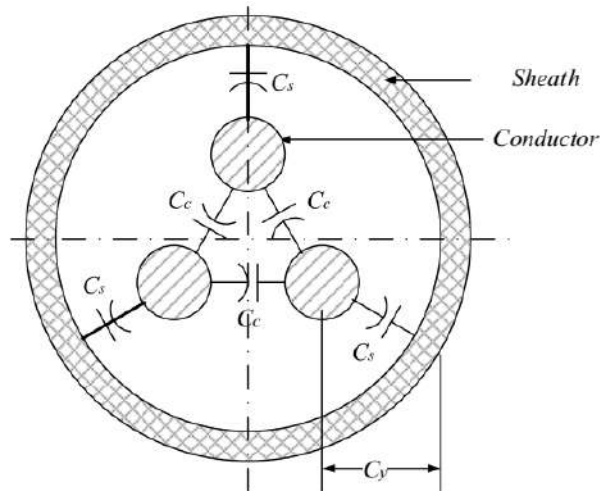

FIG.-7.6 MEASUREMENT OF CAPACITANCE OF 3-CORE CABLES (STEP-II)

Using (7.8) and (7.9) we derive the capacitance between the conductors and the conductor and Sheath.

$$C_s = \frac{1}{3} C_x \quad (7.10)$$

$$C_c = \frac{3C_y - C_x}{6} \quad (7.11)$$

From these the effective capacitance to neutral can be given by

$$C = C_s + 3C_c \quad (7.12)$$

$$C = \frac{9C_y - C_x}{6} \quad (7.13)$$

## GRADING OF CABLES

The process of achieving uniform electrostatic stress in the dielectric of cables is known as grading of cables. It has already been shown that electrostatic stress in a single core cable has a maximum value ( $g_{max}$ ) at the conductor surface and goes on decreasing as we move towards the sheath. The maximum voltage that can be safely applied to a cable depends upon  $g_{max}$  i.e., electrostatic stress at the conductor surface. For safe working of a cable having homogeneous dielectric, the strength of dielectric must be more than  $g_{max}$ . If a dielectric of high strength is used for a cable, it is useful only near the conductor where stress is maximum. But as we move away from the conductor, the electrostatic stress decreases, so the dielectric will be unnecessarily over strong. The unequal stress distribution in a cable is undesirable for two reasons. Firstly, insulation of greater thickness is required which increases the cable size. Secondly, it may lead to the breakdown of insulation. In order to overcome above disadvantages, it is necessary to have a uniform stress distribution in cables. This can be achieved by distributing the stress in such a way that its value is increased in the outer layers of dielectric. This is known as grading of cables. The following are the two main methods of grading of cables:

(i) Capacitance grading (ii) Intersheath grading

### CAPACITANCE GRADING:

The process of achieving uniformity in the dielectric stress by using layers of different dielectrics is known as capacitance grading.

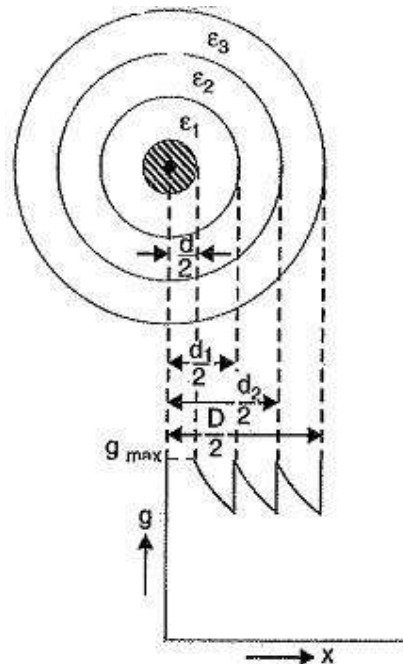

Fig. 11.15

In capacitance grading, the homogeneous dielectric is replaced by a composite dielectric. The composite dielectric consists of various layers of different dielectrics in such a manner that relative permittivity  $\epsilon_r$  of any layer is inversely proportional to its distance from the center. Under such conditions, the value of potential gradient any point in the dielectric is constant and is independent of its distance from the center. In other words, the dielectric stress in the cable is same everywhere and the grading is ideal one. However, ideal grading requires the use of an infinite number of dielectrics which is an impossible task. In practice, two or three dielectrics are used in the decreasing order of permittivity, the dielectric of highest permittivity being used near the core. The capacitance grading can be explained beautifully by referring to the above Figure. There are three dielectrics of outer diameter  $d_1$ ,  $d_2$  and  $D$  and of relative permittivity  $\epsilon_1$ ,  $\epsilon_2$  and  $\epsilon_3$  respectively. If the permittivity are such that  $\epsilon_1 > \epsilon_2 > \epsilon_3$  and the three dielectrics are worked at the same maximum stress, then

$$\epsilon_1 d = \epsilon_2 d_1 = \epsilon_3 d_2$$

$$V_1 = \frac{g_{\max}}{2} d \ln \frac{d_1}{d}$$

$$V_2 = \frac{g_{\max}}{2} d_1 \ln \frac{d_2}{d_1}$$

$$V_3 = \frac{g_{\max}}{2} d_2 \ln \frac{D}{d_2}$$

Total p.d. between core and earthed sheath is

$$V = V_1 + V_2 + V_3$$

$$V = \frac{g_{\max}}{2} \left[ d \ln \frac{d_1}{d} + d_1 \ln \frac{d_2}{d_1} + d_2 \ln \frac{D}{d_2} \right]$$

### INTER SHEATH GRADING:

In this method of cable grading, a homogeneous dielectric is used, but it is divided into various layers by placing metallic intersheaths between the core and lead sheath. The intersheaths are held at suitable potentials which are in between the core potential and earth potential. This arrangement improves voltage distribution in the dielectric of the cable and consequently more uniform potential gradient is obtained.

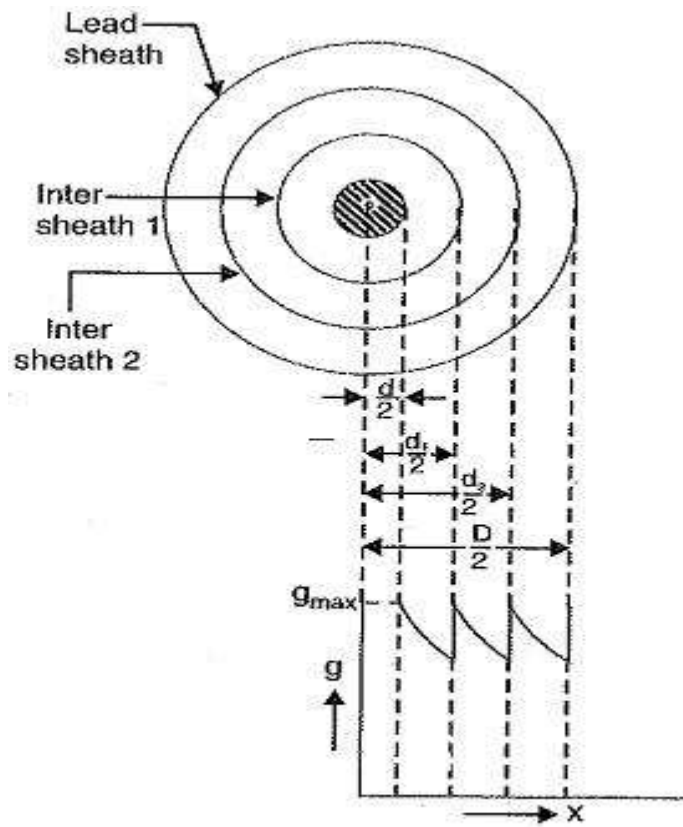

Fig. 11.17

Consider a cable of core diameter  $d$  and outer lead sheath of diameter  $D$ . Suppose that two intersheaths of diameters  $d_1$  and  $d_2$  are inserted into the homogeneous dielectric and maintained at some fixed potentials. Let  $V_1$ ,  $V_2$  and  $V_3$  respectively be the voltage between core and intersheath 1, between inter sheath 1 and 2 and between inter sheath 2 and outer lead sheath. As there is a definite potential difference between the inner and outer layers of each inter sheath, therefore, each sheath can be treated like a homogeneous single core cable. Maximum stress between core and inter sheath 1 is

$$g_{1max} = \frac{V_1}{\frac{d}{2} \log_e \frac{d_1}{d}}$$

$$g_{2max} = \frac{V_2}{\frac{d_1}{2} \log_e \frac{d_2}{d_1}}$$

$$g_{3max} = \frac{V_3}{\frac{d_2}{2} \log_e \frac{D}{d_2}}$$

Since the dielectric is homogeneous, the maximum stress in each layer is the same i.e.,

$$g_{1max} = g_{2max} = g_{3max} = g_{max}$$

$$\frac{V_1}{\frac{d}{2} \ln \frac{d_1}{d}} = \frac{V_2}{\frac{d_1}{2} \ln \frac{d_2}{d_1}} = \frac{V_3}{\frac{d_2}{2} \ln \frac{D}{d_2}}$$

As the cable behaves like three capacitors in series, therefore, all the potentials are in phase i.e. Voltage between conductor and earthed lead sheath is

$$V = V_1 + V_2 + V_3$$

Inter sheath grading has three principal disadvantages. Firstly, there are complications in fixing the sheath potentials. Secondly, the inter sheaths are likely to be damaged during transportation and installation which might result in local concentrations of potential gradient. Thirdly, there are considerable losses in the inter sheaths due to charging currents. For these reasons, inter sheath grading is rarely used.

## HV CABLE TECHNOLOGY:

High voltage cables and the insulation technology used for their manufacture are given in Table 5.4. The insulation is mainly paper based and is divided into three broad categories described as follows.

### (a) PAPER BASED LAMINATED CONSTRUCTION:

The construction of the above insulation of the high voltage cable is done by using paper. Paper provides manufacturing flexibility and it is available in high electrical quality (cellulose paper). A multiple-layer construction has the advantage that a defective layer only marginally weakens the whole system both electrically and mechanically. For the purpose of design, an AC field strength of up to 15 kV/mm or (100 kV lightning impulse) is typical for low viscosity oil impregnated paper. Typical value of dielectric constant is 3.5 and that of dielectric loss factor ( $\tan \delta$ ) is 0.0025.

**Table 5.4:** *Insulation and Technology of HV Cables*

<i>Medium Voltage (Up to 33 kV)</i>	<i>High Voltage 33 to 400 kV and above</i>
Lapped paper, dried and impregnated with viscous or non-draining compound as per BS 6480, ESI 09-12, IEC 55	Lapped paper, dried and impregnated with low viscosity oil, as per C47, NGTS 3 : 5 : 1, IEC 141-1
Extruded PVC	Extruded vulcanised (EP) rubbers
Extruded Vulcanised (EP) rubbers as per BS 6622, IEC 502	Extruded cross-linked polyethylene (XLPE) TPS 2/12
Extruded cross-linked polyethylene (XLPE) as per BS 6622, IEC 502	

### (b) POLYMERIC INSULATION:

Extrusion of a polymer to form the insulating wall of the Applications of Cables in Engineering Works offers the possibility of high production speed along with the advantages of polymeric materials. Polymers can be selected to have dielectric losses less than 10% of the cellulose paper and the intrinsic dielectric strength as high as 4 times that of oil impregnated paper and thermal conductance 30% higher. The disadvantage of this type of insulation is that a single defect can have a disastrous effect on the dielectric integrity of the whole cable. At voltages of 120 kV and below compounds of ethylene-propylene (EP) rubber are being used. The benefit of this material is that it is water resistant. An alternative to EP rubbers in XLPE.

## XLPE CABLES

Extra-high voltage cables over 66-kV rating may be categorized into OF (Oil Filled), POF (Pipe Oil Filled) and CV (Cross-Linked Polyethylene Insulated PVC Sheathed, i.e., XLPE) cables, XLPE cable has made a remarkable progress since its first application 50 years ago, with respect to the material, structure, manufacturing technology and quality control technology. Because XLPE cable is characterized by its ease of maintenance, the cable rapidly proliferated domestically

in the 1960s when its application began, currently constituting the majority of domestic power cables having voltage ratings of 66-kV and higher. Moreover, since the late 1990s when 500-kV XLPE cables have been put into actual use, studies have been made focusing on simplifying the installation process for joints as well as reducing their sizes, and new joints that utilize new structures and materials have been developed for practical application.

### **UNDERGROUND DISTRIBUTION CABLE**

Underground distribution cables range from 6.6 kV to 33 kV in voltage rating, and XLPE cables that employ crosslinked polyethylene as insulator are generally used. It may be said that the history of XLPE cable is the history of countermeasures against water tree, a process of insulation deterioration due to water absorption. Water tree is a phenomenon in which water penetrates into insulation under the influence of electric fields forming a dendritic (tree-like) array of voids filled with water, thereby degrading the insulation performance. Moreover, water-impervious XLPE cables were developed and applied in the late 1980s centering on the 22- kV and 33-kV XLPE cables, with the aim of improving the reliability further by completely preventing entry of water into the cables. The water-impervious tape consisted of a laminated lead tape which is laminated with a lead foil and plastics to improve the extensibility, making it possible for the tape to follow the thermal expansion and contraction of the cable. This laminated lead layer was bonded on the inside of the cable sheath, constituting a water impervious cable.

### **HIGH-PRESSURE, FLUID-FILLED PIPE-TYPE CABLE**

A high-pressure, fluid-filled (HPFF) pipe-type of underground transmission line, consists of a steel pipe that contains three high-voltage conductors. Each conductor is made of copper or aluminum; insulated with high-quality, oil-impregnated kraft paper insulation; and covered with metal shielding (usually lead) and skid wires (for protection during construction). Inside steel pipes, three conductors are surrounded by a dielectric oil which is maintained at 200 pounds per square inch (psi). This fluid acts as an insulator and does not conduct electricity. The pressurized dielectric fluid prevents electrical discharges in the conductors' insulation. An electrical discharge can cause the line to fail. The fluid also transfers heat away from the conductors. The fluid is usually static and removes heat by conduction. In some situations the fluid is pumped through the pipe and cooled through the use of a heat exchanger. Cables with pumped fluids require aboveground pumping stations, usually located within substations. The pumping stations monitor the pressure and temperature of the fluid. There is a radiator-type device that moves the heat from the underground cables to the atmosphere. The oil is also monitored for any degradation or trouble with the cable materials.

### **HIGH-PRESSURE, GAS-FILLED PIPE-TYPE CABLE**

The high-pressure, gas-filled (HPGF) pipe-type of underground transmission line is a variation of the HPFF pipe-type, described above. Instead of dielectric oil, pressurized nitrogen gas is used to insulate the conductors. Nitrogen gas is less effective than dielectric fluids at suppressing electrical discharges and cooling. To compensate for this, the conductors' insulation is about 20 percent thicker than the insulation in fluid-filled pipes. Thicker insulation and a warmer pipe reduce the amount of current the line can safely and efficiently carry. In case of a leak or

break in the cable system, the nitrogen gas is easier to deal with than the dielectric oil in the surrounding environment.

Cables have a much lower inductance than overhead lines due to the lower spacing between conductor and earth, but have a correspondingly higher capacitance, and hence a much higher charging current. High voltage cables are generally single cored, and hence have their separate insulation and mechanical protection by sheaths. In the older paper insulated cables, the sheath was of extruded lead. The presence of the sheath introduces certain difficulties as currents are induced in the sheath as well. This is due to fact that the sheaths of the conductors cross the magnetic fields set up by the conductor currents. At all points along the cable, the magnetic field is not the same, Hence different voltages are induced at different points on the sheath. This causes eddy currents to flow in the sheaths. These eddy currents depend mainly on (a) the frequency of operation, (b) the distance between cables, (c) the mean radius of the sheath, and (d) the resistivity of the sheath material

## UNIT - III

### D.C DISTRIBUTION SYSTEMS

#### INTRODUCTION:

Electrical distribution systems are an essential part of the electrical power system. In order to transfer electrical power from an alternating-current or a direct-current source to the place where it will be used, some type of distribution network must be utilized. The method used to distribute power from where it is produced to where it is used can be quite simple. More complex power distribution systems are used, to transfer electrical power from the power plant to industries, homes, and commercial buildings. Distribution systems usually employ such equipment as transformers, circuit breakers, and protective devices. The original electrical distribution system developed by Thomas Edison was an underground direct current (DC) system.

In general, the distribution system is the electrical system between the sub-station fed by the transmission system and the consumer end. It generally consists of feeders, distributors. The single line diagram of a typical distribution system is shown in Fig.-8.1. Basically we can say, that part of power system which distributes electric power for local use is known as distribution system.

#### DISTRIBUTION SYSTEM

*That part of power system which distributes electric power for local use is known as distribution system.*

In general, the distribution system is the electrical system between the sub-station fed by the distribution system and the consumer's meters. It generally consists of *feeders*, *distributors* and the *service mains*.

- (i) **Feeders.** A feeder is a conductor which connects the sub-station (or localized generating station) to the area where power is to be distributed. Generally, no tappings are taken from the feeder so that current in it remains the same throughout. The main consideration in the design of a feeder is the current carrying capacity.

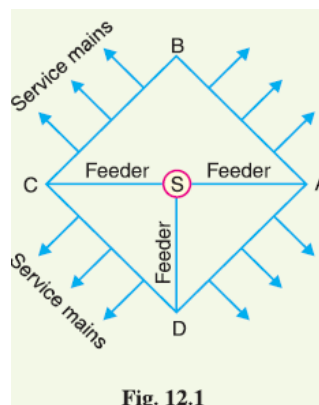

Fig. 12.1

- (ii) **Distributor.** A distributor is a conductor from which tappings are taken for supply to the consumers. In Fig. 12.1, *AB*, *BC*, *CD* and *DA* are the distributors. The current through a distributor is not constant because tappings are taken at various places along its length. While designing a distributor, voltage drop along its length is the main consideration since the statutory limit of voltage variations is  $\pm 6\%$  of rated value at the consumers' terminals.
- (iii) **Service mains.** A service mains is generally a small cable which connects the distributor to the consumers' terminals.

### CLASSIFICATION OF DISTRIBUTION SYSTEMS:

A distribution system may be classified according to ;

- (i) **Nature of current.** According to nature of current, distribution system may be classified as  
(a) **D.C distribution system** (b) **A.C distribution system.**

Now-a-days, A.C system is universally adopted for distribution of electric power as it is simpler and more economical than direct current method.

- (ii) **Type of construction.** According to type of construction, distribution system may be classified as (a) **overhead system** (b) **underground system.**

The overhead system is generally employed for distribution as it is 5 to 10 times cheaper than the equivalent underground system. In general, the underground system is used at places where overhead construction is impracticable or prohibited by the local laws.

- (iii) **Scheme of connection.** According to scheme of connection, the distribution system may be classified as (a) **Radial system** (b) **Ring main system** (c) **Inter-connected system.** Each scheme has its own advantages and disadvantages

### A.C. Distribution

- Now-a-days electrical energy is generated, transmitted and distributed in the form of alternating current.
- Alternating current is preferred to direct current is the fact that alternating voltage can be conveniently changed by current means of a transformer.
- High distribution and distribution voltages have greatly reduced the current in the conductors and the resulting line losses.

The A.C distribution system is the electrical system between the step down substation fed by the distribution system and the consumers' meters.

The A.C. distribution system is classified into

- Primary Distribution System and Secondary Distribution System.

### PRIMARY DISTRIBUTION SYSTEM

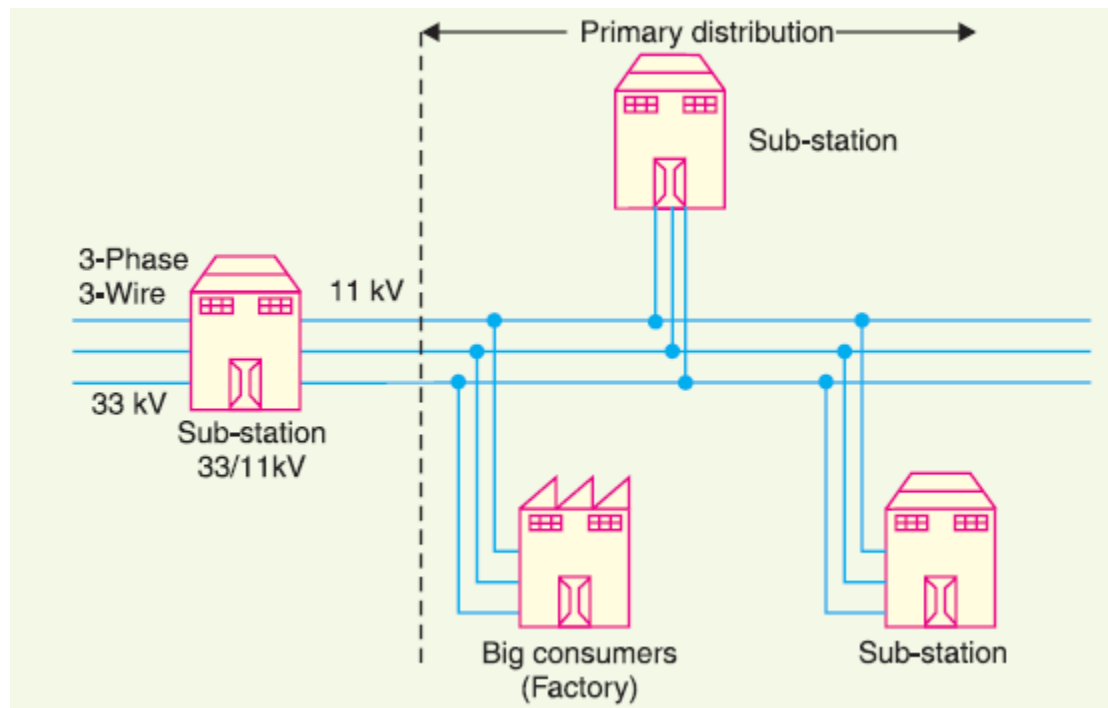

It is that part of A.C. distribution system which operates at voltages somewhat higher than general utilisation than the average low-voltage consumer uses

- The most commonly used primary distribution voltages are 11 kV, 6.6kV and 3.3 kV

Primary distribution is carried out by 3-phase, 3-wire system.

- Fig. shows a typical primary distribution system.

Electric power from the generating station is transmitted at high voltage to the substation located in or near the city. At this substation, voltage is stepped down to 11 kV with the help of step-down transformer. Power is supplied to various substations for distribution or to big consumers at this voltage. This forms the high voltage distribution or primary distribution

## SECONDARY DISTRIBUTION SYSTEM.

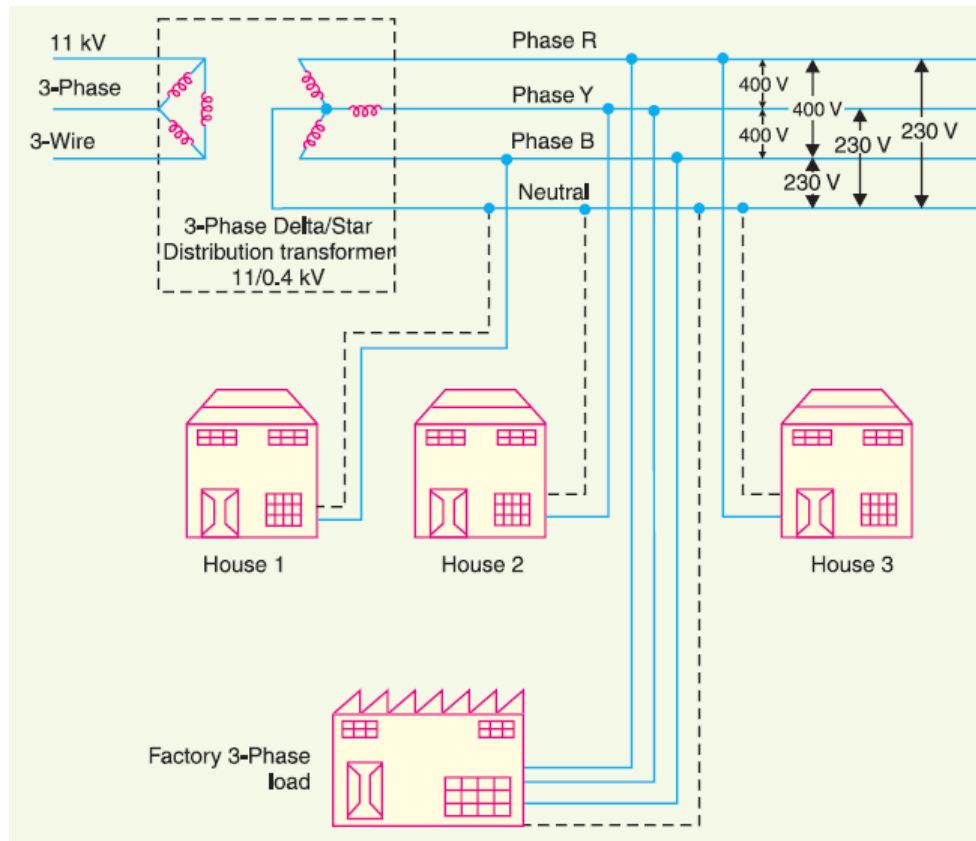

It is that part of A.C. distribution system employs 400/230 V, 3-phase, 4-wire system.

- shows a typical secondary distribution system.
- The primary distribution circuit delivers power to various substations, called distribution substations. The substations are situated near the consumers' localities and contain step down transformers.
- At each distribution substation, the voltage is stepped down to 400 V and power is delivered by 3-phase,4-wire a.c. system.
- The voltage between any two phases is 400 V and between any phase and neutral is 230 V.

The single phase domestic loads are connected between any one phase and the neutral,.

- Motor loads are connected across 3-phase lines directly.

**DC DISTRIBUTION SYSTEM:**

It is a common knowledge that electric power is almost exclusively generated, transmitted and distributed as A.C. However, for certain applications, D.C. supply is absolutely necessary. For instance, D.C. supply is required for the operation of variable speed machinery (i.e., D.C. motors), for electrochemical work and for congested areas where storage battery reserves are necessary. For this purpose, A.C. power is converted into D.C. power at the substation by using converting machinery e.g., mercury arc rectifiers, rotary converters and motor-generator sets.

The DC Distribution System from the substation may be obtained in the form of

- **Two Wire DC Distribution System**
- **Three Wire DC Distribution System**

- (i) **Two Wire DC Distribution System:** As the name implies, this system of distribution consists of two wires. One is the outgoing or positive wire and the other is the return or negative wire. The loads such as lamps, motors etc. are connected in parallel between the two wires as shown in Fig. 12.4. This system is never used for transmission purposes due to low efficiency but may be employed for distribution of D.C. power.

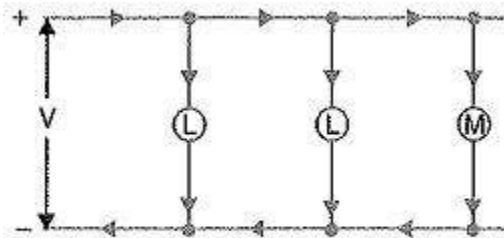

Fig. 12.4

- (ii) **Three Wire DC Distribution System:** It consists of two outers and a middle or neutral wire which is earthed at the substation. The voltage between the outers is twice the voltage between either outer or neutral wire as shown in Fig. 12.5. The principal advantage of this system is that it makes available two voltages at the consumer terminals viz.,  $V$  between any outer and the neutral and  $2V$  between the outers. Loads requiring high voltage (e.g., motors) are connected across the outers, whereas lamps and heating circuits requiring less voltage are connected between either outer and the neutral. The methods of obtaining 3-wire system are discussed in the following

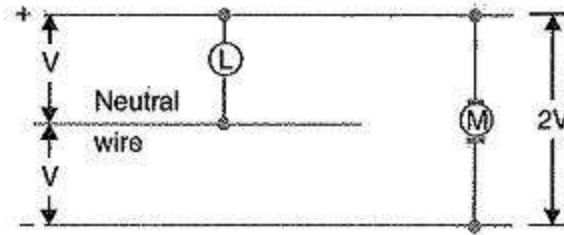

Fig. 12.5

### METHODS OF OBTAINING THREE WIRE DC DISTRIBUTION SYSTEM:

There are several methods of obtaining 3-wire D.C. system. However, the most important ones are:

#### TWO GENERATOR METHOD:

In this method, two shunt wound D.C. generators  $G_1$  and  $G_2$  are connected in series and the neutral is obtained from the common point between generators as shown in Fig. 12.6 (i). Each generator supplies the load on its own side. Thus generator  $G_1$  supplies a load current of  $I_1$ , whereas generator  $G_2$  supplies a load current of  $I_2$ . The difference of load currents on the two sides, known as out of balance current ( $I_1 - I_2$ ) flows through the neutral wire. The principal disadvantage of this method is that two separate generators are required.

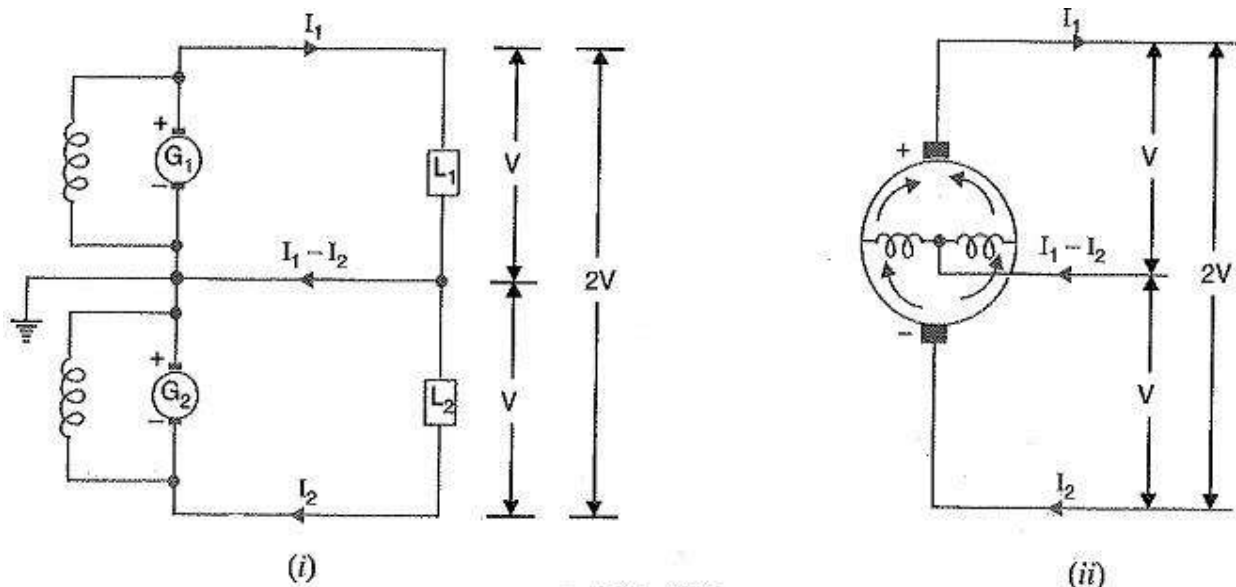

Fig. 12.6

**3-WIRE D.C. GENERATOR:** The above method is costly on account of the necessity of two gen For this reason, 3-wire D.C. generator was developed as shown in Fig. 12.6 (ii). It consists of a standard 2-wire machine with one or two coils of high reactance and low resistance, connected

permanently to diametrically opposite points of the armature winding. The neutral wire is obtained from the common point as shown.

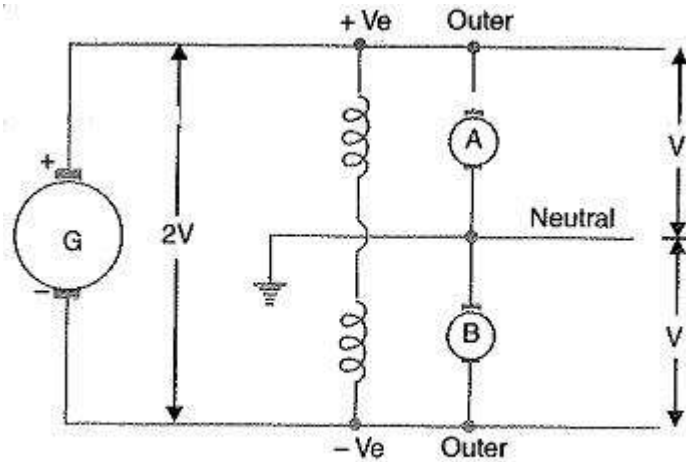

Fig. 12.7

**BALANCER SET:** The 3-wire system can be obtained from 2-wire D.C. system by the use of balancer set as shown in Fig. 12.7. G is the main 2-wire D.C. generator and supplies power to the whole system. The balancer set consists of two identical D.C. shunt machines A and B coupled mechanically with their armatures and field windings joined in series across the outers. The junction of their armatures is earthed and neutral wire is taken out from here. The balancer set has the additional advantage that it maintains the potential difference on two sides of neutral equal to each other.

### COMPARISON OF D.C. AND A.C. DISTRIBUTION

The electric power can be distributed either by means of D.C. or A.C. Each system has its own merits and demerits

#### D.C DISTRIBUTION

##### Advantages:

- It requires only two conductors as compared to three for A.C. distribution.
- There is no inductance, capacitance, phase displacement and surge problems in D.C. distribution.
- Due to the absence of inductance, the voltage drop in a D.C. distribution line is less than the A.C. line for the same load and sending end voltage. For this reason, a D.C. distribution line has better voltage regulation.
- There is no skin effect in a D.C. system. Therefore, entire cross-section of the line conductor is utilized.
- For the same working voltage, the potential stress on the insulation is less in case of D.C. system than that in A.C. system. Therefore, a D.C. line requires less insulation.

- A D.C. line has less corona loss and reduced interference with communication circuits.
- The high voltage D.C. distribution is free from the dielectric losses, particularly in
- In D.C distribution, there are no stability problems and synchronizing difficulties.

#### **Disadvantages**

- Electric power cannot be generated at high D.C. voltage due to commutation problems.
- The D.C. voltage cannot be stepped up for distribution of power at high voltages.
- The D.C. switches and circuit breakers have their own limitations.

### **A.C DISTRIBUTION**

#### **Advantages**

- The power can be generated at high voltages.
- The maintenance of A.C. sub-stations is easy and cheaper.
- The A.C. voltage can be stepped up or stepped down by transformers with ease and efficiency. This permits to transmit power at high voltages and distribute it at safe potentials.

#### **Disadvantages**

- The construction of A.C distribution line is more complicated than a D.C distribution line.
- Due to skin effect in the A.C. system, the effective resistance of the line is increased.
- An A.C. line has capacitance. Therefore, there is a continuous loss of power due to charging current even when the line is open.
- An A.C. line requires more copper than a D.C. line.

### **OVERHEAD VERSUS UNDERGROUND SYSTEM**

The distribution system can be overhead or underground.

- Overhead lines are generally mounted on wooden concrete or steel poles which are arranged to carry distribution transformers in addition to the conductors
- The underground system uses conduits and cables and manholes under the surface of streets and sidewalks.

The choice between overhead and underground system depends upon a number of widely differing factors.

- (i) **Public safety.** The underground system is safer than overhead system because all distribution wiring is placed underground and there are little chances of any hazard.

- (ii) **Initial cost.** The underground system is more expensive due to the high cost of trenching, conduits, cables, manholes and other special equipment. The initial cost of an underground system may be five to ten times than that of an overhead system.
- (iii) **Flexibility.** The overhead system is much more flexible than the underground system. In the latter case, manholes, duct lines etc., are permanently placed once installed and the load expansion can only be met by laying new lines. However, on an overhead system, poles, wires, transformers etc., can be easily shifted to meet the changes in load conditions.
- (iv) **Faults.** The chances of faults in underground system are very rare as the cables are laid underground and are generally provided with better insulation.
- (v) **Appearance.** The general appearance of an underground system is better as all the distribution lines are invisible. This factor is exerting considerable public pressure on electric supply companies to switch over to underground system.
- (vi) **Fault location and repairs.** In general, there are little chances of faults in an underground system. However, if a fault does occur, it is difficult to locate and repair on this system. On an overhead system, the conductors are visible and easily accessible so that fault locations and repairs can be easily made.
- (vii) **Current carrying capacity and voltage drop.** An overhead distribution conductor has a considerably higher current carrying capacity than an underground cable conductor of the same material and cross-section. On the other hand, underground cable conductor has much lower inductive reactance than that of an overhead conductor because of closer spacing of conductors.
- (viii) **Useful life.** The useful life of underground system is much longer than that of an overhead system. An overhead system may have a useful life of 25 years, whereas an underground system may have a useful life of more than 50 years.
- (ix) **Maintenance cost.** The maintenance cost of underground system is very low as compared with that of overhead system because of fewer chances of faults and service interruptions from wind, ice, and lightning as well as from traffic hazards.
- (x) **Interference with communication circuits.** An overhead system causes electromagnetic interference with the telephone lines. The power line currents are superimposed on speech currents, resulting in the potential of the communication channel being raised to an undesirable level. However, there is no such interference with the underground system.

#### **DESIGN CONSIDERATIONS IN DISTRIBUTION SYSTEM:**

Good voltage regulation of a distribution network is probably the most important factor responsible for delivering good service to the consumers. For this purpose, design of feeders and distributors requires careful consideration.

(i) **Feeders.** A feeder is designed from the point of view of its current carrying capacity while the voltage drop consideration is relatively unimportant. It is because voltage drop in a feeder can be compensated by means of voltage regulating equipment at the substation.

(ii) **Distributors.** A distributor is designed from the point of view of the voltage drop in it. It is because a distributor supplies power to the consumers and there is a statutory limit of voltage variations at the consumer's terminals ( $\pm 6\%$  of rated value). The size and length of the distributor should be such that voltage at the consumer's terminals is within the permissible limits.

### REQUIREMENTS OF A DISTRIBUTION SYSTEM

Requirements of a good distribution system are: proper voltage, availability of power on demand and reliability.

(i) **Proper voltage.** One important requirement of a distribution system is that voltage variations at consumer's terminals should be as low as possible. The changes in voltage are generally caused due to the variation of load on the system. Low voltage causes loss of revenue, inefficient lighting and possible burning out of motors. High voltage causes lamps to burn out permanently and may cause failure of other appliances. Therefore, a good distribution system should ensure that the voltage variations at consumer's terminals are within permissible limits. The statutory limit of voltage variations is  $\pm 6\%$  of the rated value at the consumer's terminals. Thus, if the declared voltage is 230 V, then the highest voltage of the consumer should not exceed 244 V while the lowest voltage of the consumer should not be less than 216 V.

(ii) **Availability of power on demand.** Power must be available to the consumers in any amount that they may require from time to time. For example, motors may be started or shut down, lights may be turned on or off, without advance warning to the electric supply company. As electrical energy cannot be stored, therefore, the distribution system must be capable of supplying load demands of the consumers. This necessitates that operating staff must continuously study load patterns to predict in advance those major load changes that follow the known schedules.

(iii) **Reliability.** Modern industry is almost dependent on electric power for its operation. Homes and office buildings are lighted, heated, cooled and ventilated by electric power. This calls for reliable service. Unfortunately, electric power, like everything else that is man-made, can never be absolutely reliable. However, the reliability can be improved to a considerable extent by

(a) **interconnected system**

- (b) reliable automatic control system
- (c) providing additional reserve facilities.

### CONNECTION SCHEMES OF DISTRIBUTION SYSTEM

All distribution of electrical energy is done by constant voltage system.

In practice, the following distribution circuits are generally used :

#### i) RADIAL SYSTEM:

In this system, separate feeders radiate from a single substation and feed the distributors at one end only. Fig. 12.8 (i) shows a single line diagram of a radial system for D.C distribution where a feeder OC supplies a distributor A B at point A . Obviously, the distributor is fed at one end only i.e., point A is this case. Fig. 12.8 (ii) shows a single line diagram of radial system for A.C distribution. The radial system is employed only when power is generated at low voltage and the substation is located at the centre of the load.

This is the simplest distribution circuit and has the lowest initial cost.

However, it suffers from the following drawbacks:

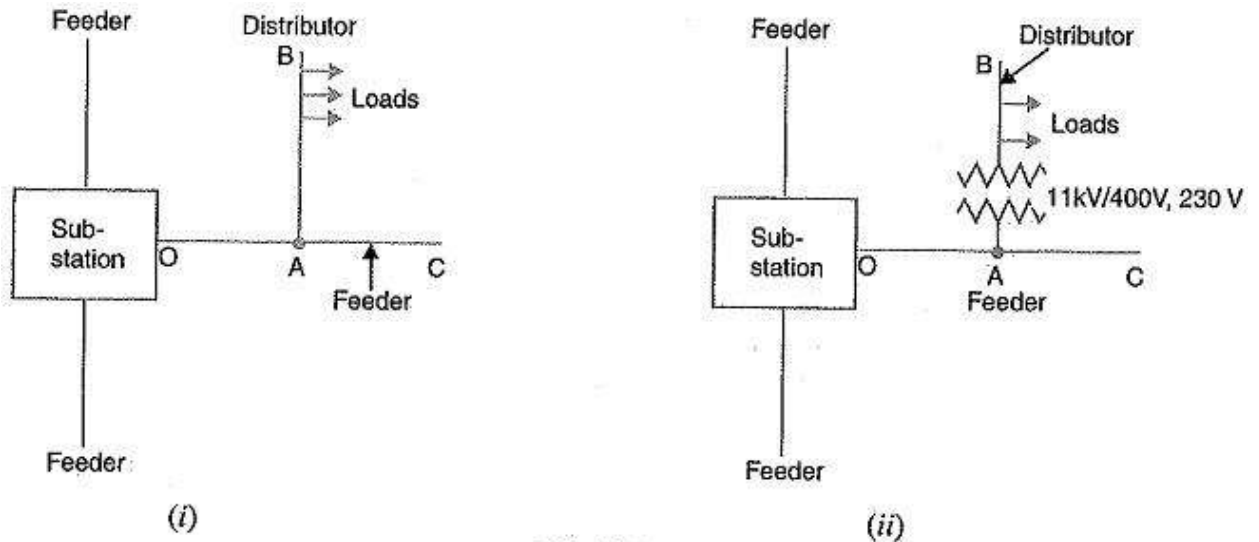

Fig. 12.8

- The end of the distributor nearest to the feeding point will be heavily loaded.
- The consumers are dependent on a single feeder and single distributor. Therefore, any fault on the feeder or distributor cuts off supply to the consumers who are on the side of the fault away from the substation.
- The consumers at the distant end of the distributor would be subjected to serious voltage fluctuations when the load on the distributor changes.

Due to these limitations, this system is used for short distances only.

### i) RING MAIN SYSTEM.

In this system, the primaries of distribution transformers form a loop. The loop circuit starts from the substation bus-bars, makes a loop through the area to be served, and returns to the substation. Fig. 12.9 shows the single line diagram of ring main system for a.c. distribution where substation supplies to the closed feeder LMNOPQRS.

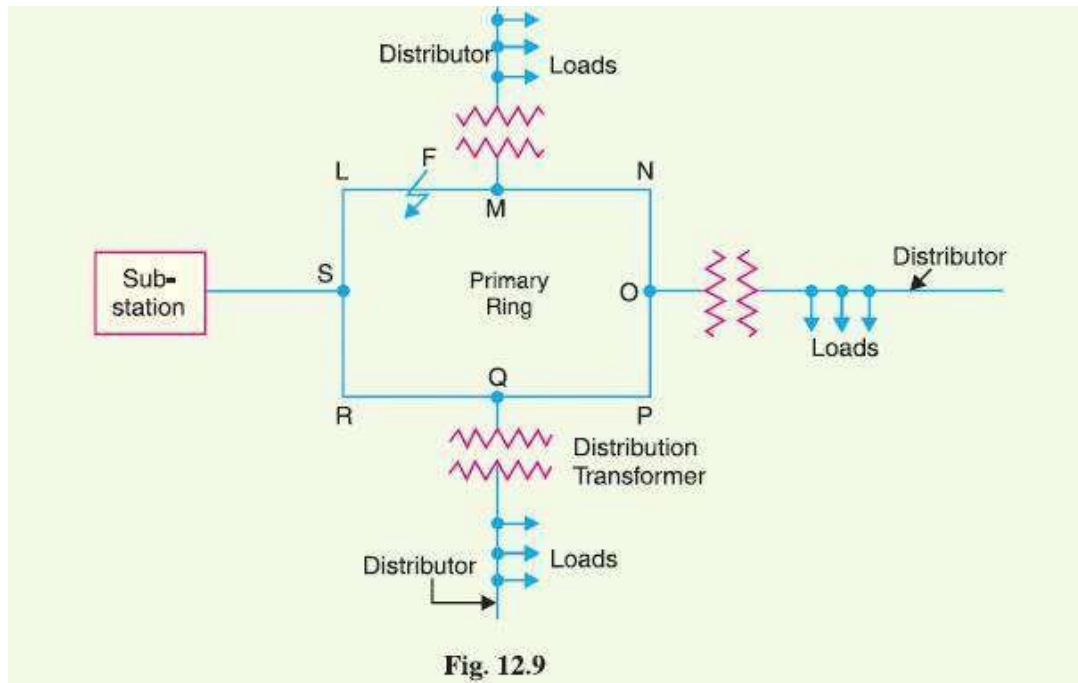

The distributors are tapped from different points M, O and Q of the feeder through distribution transformers. The ring main system has the following advantages:

- There are less voltage fluctuations at consumer's terminals.
- The system is very reliable as each distributor is fed via \*two feeders. In the event of fault on any section of the feeder, the continuity of supply is maintained. For example, suppose that fault occurs at any point F of section SLM of the feeder. Then section SLM of the feeder can be isolated for repairs and at the same time continuity of supply is maintained to all the consumers via the feeder SRQPONM.

### ii) INTERCONNECTED SYSTEM:

When the feeder ring is energized by two or more than two generating stations or substations, it is called inter-connected system. Fig. 12.10 shows the single line diagram of interconnected system where the closed feeder ring ABCD is supplied by two substations S and S at points D and C respectively. Distributors are connected to points O, P, Q and R of the feeder ring through distribution transformers.

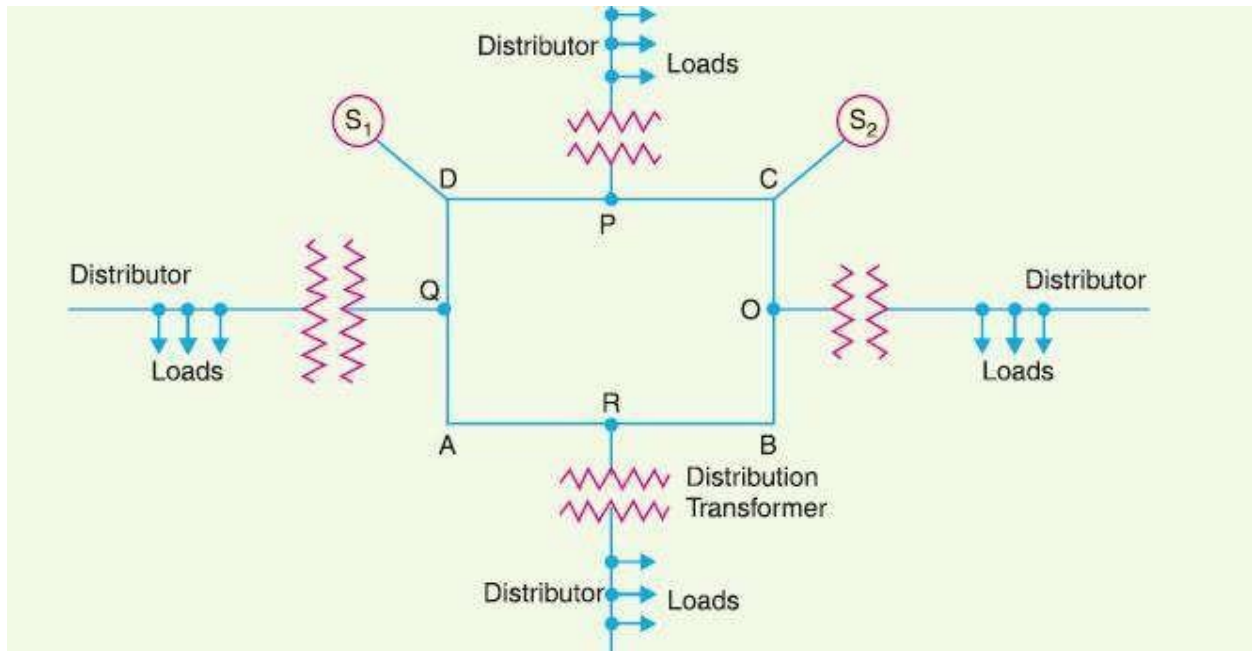

The interconnected system has the following advantages:

- It increases the service reliability.
- Any area fed from one generating station during peak load hours can be fed from the other generating station. This reduces reserve power capacity and increases efficiency of the system.

**DC DISTRIBUTION CALCULATION:**

In addition to the methods of feeding discussed above, a DC Distribution Calculation may have

- **Concentrated Loading**
- **Uniform Loading**
- **Both Concentrated and Uniform Loading.**

The concentrated loads are those which act on particular points of the distributor. A common example of such loads is that tapped off for domestic use. On the other hand, distributed loads are those which act uniformly on all points of the distributor. Ideally, there are no distributed loads. However, a nearest example of distributed load is a large number of loads of same wattage connected to the DC Distribution Calculation at equal distances. In DC Distribution Calculation, one important point of interest is the determination of point of minimum potential on the distributor. The point where it occurs depends upon the loading conditions and the method of feeding the distributor. The distributor is so designed that the minimum potential on it is not less than 6% of rated voltage at the consumer's terminals. In the next sections, we shall discuss some important cases of d.c. distributors separately.

**DC DISTRIBUTOR FED AT ONE END — CONCENTRATED LOADING:**

Fig. shows the single line diagram of a 2-wire D.C distributor AB fed at one end A and having concentrated loads  $I_1$ ,  $I_2$ ,  $I_3$  and  $I_4$  tapped off at points C, D, E and F respectively.

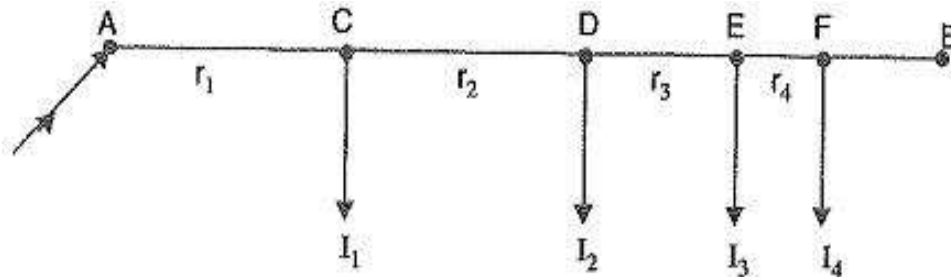

**Fig. 13.5**

Let  $r_1$ ,  $r_2$ ,  $r_3$  and  $r_4$  be the resistances of both wires (go and return) of the sections AC, CD, DE and EF of the distributor respectively.

Current fed from point A	$= I_1 + I_2 + I_3 + I_4$
Current in section AC	$= I_1 + I_2 + I_3 + I_4$
Current in section CD	$= I_2 + I_3 + I_4$
Current in section DE	$= I_3 + I_4$
Current in section EF	$= I_4$
Voltage drop in section AC	$= r_1 (I_1 + I_2 + I_3 + I_4)$
Voltage drop in section CD	$= r_2 (I_2 + I_3 + I_4)$
Voltage drop in section DE	$= r_3 (I_3 + I_4)$
Voltage drop in section EF	$= r_4 I_4$

Total voltage drop in the DC Distribution Calculation is

$$= r_1 (I_1 + I_2 + I_3 + I_4) + r_2 (I_2 + I_3 + I_4) + r_3 (I_3 + I_4) + r_4 I_4$$

It is easy to see that the minimum potential will occur at point F which is farthest from the feeding point A.

#### UNIFORMLY LOADED DISTRIBUTOR FED AT ONE END:

Fig 13.11 shows the single line diagram of a 2-wire d.c. distributor AB fed at one end A and loaded uniformly with  $i$  amperes per metre length. It means that at every 1 m length of the distributor, the load tapped is  $i$  amperes. Let  $l$  metres be the length of the distributor and  $r$  ohm be the resistance per metre run.

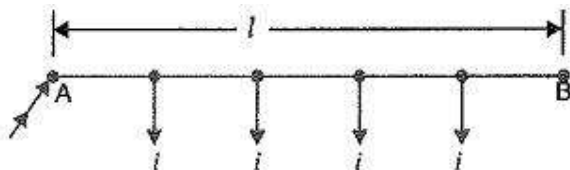

Fig. 13.11

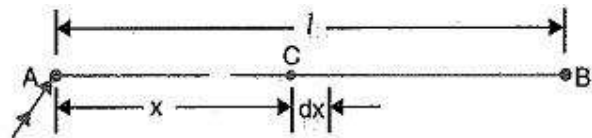

Fig. 13.12

Consider a point C on the distributor at a distance  $x$  metres from the feeding point A as shown in Fig. 13.12. Then current at point C is

$$= il - ix \text{ amperes} = i(l - x) \text{ amperes}$$

Now, consider a small length  $dx$  near point C. Its resistance is  $r dx$  and the voltage drop over length  $dx$  is

$$dv = i(l-x)r dx = ir(l-x) dx$$

Total voltage drop in the distributor upto point C is

$$v = \int_0^x ir(l-x) dx = ir \left( lx - \frac{x^2}{2} \right)$$

The voltage drop upto point B (i.e. over the whole distributor) can be obtained by putting  $x = l$  in the above expression. Voltage drop over the distributor AB

$$\begin{aligned} &= ir \left( l \times l - \frac{l^2}{2} \right) \\ &= \frac{1}{2} ir l^2 = \frac{1}{2} (il) (rl) \\ &= \frac{1}{2} IR \\ il &= I, \text{ the total current entering at point A} \\ rl &= R, \text{ the total resistance of the distributor} \end{aligned}$$

Thus, in a uniformly loaded distributor fed at one end, the total voltage drop is equal to that produced by the whole of the load assumed to be concentrated at the middle point.

### **DISTRIBUTOR FED AT BOTH ENDS — CONCENTRATED LOADING:**

Whenever possible, it is desirable that a long distributor should be fed at both ends instead of at one end only, since total voltage drop can be considerably reduced without increasing the cross-section of the conductor. The two ends of the distributor may be supplied with (i) equal voltages (ii) unequal voltages.

#### **1. TWO ENDS FED WITH EQUAL VOLTAGES:**

Consider a distributor AB fed at both ends with equal voltages  $V$  volts and having concentrated loads  $I_1, I_2, I_3, I_4$  and  $I_5$  at points C, D, E, F and G respectively as shown in Fig. 13.14. As we move away from one of the feeding points, say A, p.d. goes on decreasing till it reaches the minimum value at some load point, say E, and then again starts rising and becomes  $V$  volts as we reach the other feeding point B.

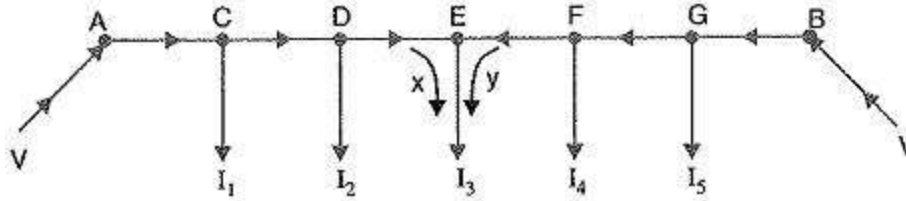

Fig. 13.14

All the currents tapped off between points A and E (minimum p.d. point) will be supplied from the feeding point A while those tapped off between B and E will be supplied from the feeding point B. The current tapped off at point E itself will be partly supplied from A and partly from B. If these currents are x and y respectively, then,

$$I_3 = x + y$$

Therefore, we arrive at a very important conclusion that at the point of minimum potential, current comes from both ends of the DC Distribution Calculation.

**POINT OF MINIMUM POTENTIAL:**

It is generally desired to locate the point of minimum potential. There is a simple method for it. Consider a distributor AB having three concentrated loads  $I_1$ ,  $I_2$  and  $I_3$  at points C, D and E respectively. Suppose that current supplied by feeding end A is  $I_A$ . Then current distribution in the various sections of the distributor can be worked out as shown in Fig. 13.15 (i). Thus

$$I_{AC} = I_A;$$

$$I_{DE} = I_A - I_1 - I_2;$$

$$I_{CD} = I_A - I_1$$

$$I_{EB} = I_A - I_1 - I_2 - I_3$$

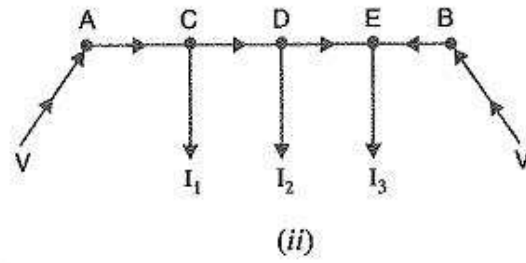
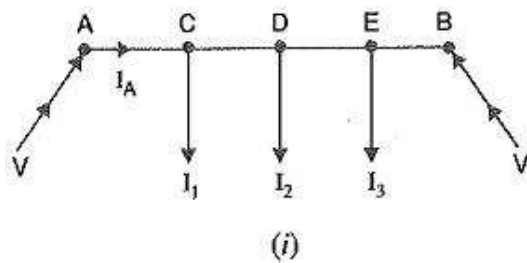

Fig. 13.15

Voltage drop between A and B = Voltage drop over AB

or  $V - V = I_A R_{AC} + (I_A - I_1) R_{CD} + (I_A - I_1 - I_2) R_{DE} + (I_A - I_1 - I_2 - I_3) R_{EB}$

From this equation, the unknown  $I_A$  can be calculated as the values of other quantities are generally given. Suppose actual directions of currents in the various sections of the distributor are indicated as shown in Fig. 13.15 (ii). The load point where the currents are coming from both sides of the distributor is the point of minimum potential i.e. point E in this case

### (II) TWO ENDS FED WITH UNEQUAL VOLTAGES:

Fig. 13.16 shows the distributor AB fed with unequal voltages ; end A being fed at  $V_1$  volts and end B at  $V_2$  volts. The point of minimum potential can be found by following the same procedure as discussed above. Thus in this case,

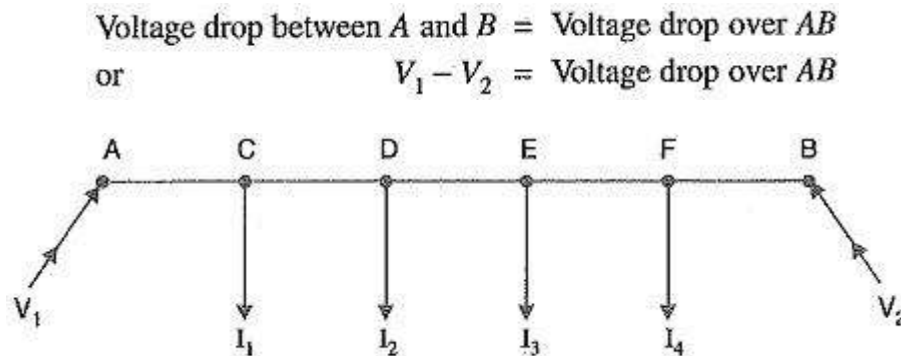

Fig. 13.16

### UNIFORMLY LOADED DISTRIBUTOR FED AT BOTH ENDS:

We shall now determine the voltage drop in a uniformly loaded distributor fed at both ends. There can be two cases viz the distributor fed at both ends with (i) equal voltages (ii) unequal voltages. The two cases shall be discussed separately.

#### DISTRIBUTOR FED AT BOTH ENDS WITH EQUAL VOLTAGES:

Consider a distributor AB of length  $l$  metres, having resistance  $r$  ohms per metre run and with uniform loading of  $i$  amperes per metre run as shown in Fig. 13.24. Let the DC Distribution Calculation be fed at the feeding points A and B at equal voltages, say  $V$  volts. The total current supplied to the distributor is  $i l$ . As the two end voltages are equal, therefore, current supplied from each feeding point is  $i l / 2$  i.e. Current supplied from each feeding point

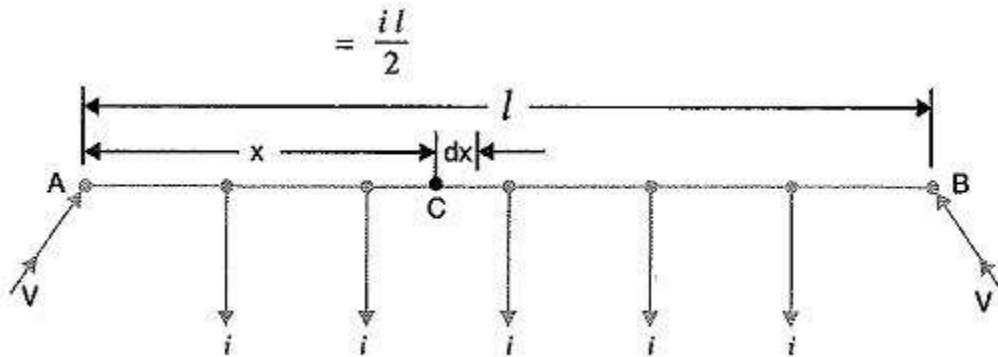

Fig. 13.24

Consider a point C at a distance  $x$  metres from the feeding point A. Then current at point C is

$$= \frac{il}{2} - ix = i \left( \frac{l}{2} - x \right)$$

Now, consider a small length  $dx$  near point C. Its resistance is  $r dx$  and the voltage drop over length  $dx$  is

$$dv = i \left( \frac{l}{2} - x \right) r dx = ir \left( \frac{l}{2} - x \right) dx$$

$$\begin{aligned} \text{Voltage drop upto point C} &= \int_0^x ir \left( \frac{l}{2} - x \right) dx = ir \left( \frac{lx}{2} - \frac{x^2}{2} \right) \\ &= \frac{ir}{2} (lx - x^2) \end{aligned}$$

Obviously, the point of minimum potential will be the mid-point. Therefore, maximum voltage drop will occur at mid-point i.e. where  $x = l/2$ .

$$\begin{aligned} \text{Max. voltage drop} &= \frac{ir}{2} (lx - x^2) \\ &= \frac{ir}{2} \left( l \times \frac{l}{2} - \frac{l^2}{4} \right) && \text{[Putting } x = \\ &= \frac{1}{8} ir l^2 = \frac{1}{8} (il)(rl) = \frac{1}{8} IR \end{aligned}$$

$il = I$ , the total current fed to the distributor from both ends

$rl = R$ , the total resistance of the distributor

$$\text{Minimum voltage} = V - \frac{IR}{8} \text{ volts}$$

**DISTRIBUTOR FED AT BOTH ENDS WITH UNEQUAL VOLTAGES:**

Consider a distributor AB of length (metres) having resistance  $r$  ohms per metre run and with a uniform loading of  $i$  amperes per metre run as shown in Fig. 13.25. Let the DC Distribution Calculation be fed from feeding points A and B at voltages  $V_A$  and  $V_B$  respectively. Suppose that the point of minimum potential C is situated at a distance  $x$  metres from the feeding point A. Then current supplied by the feeding point A will be  $i x$ .

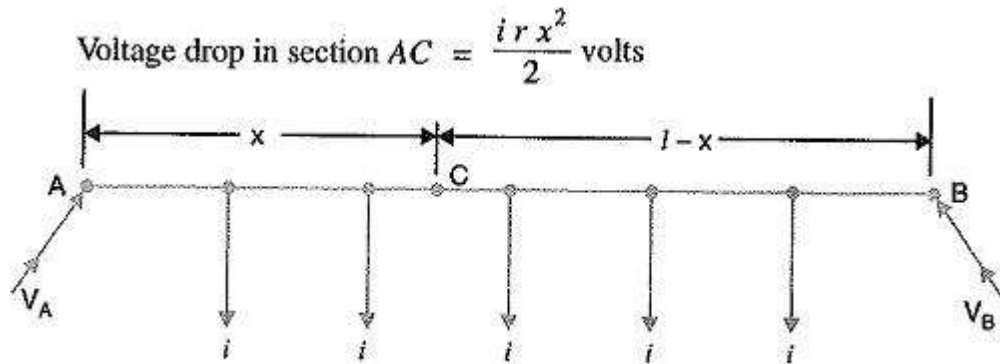

Fig. 13.25

As the distance of C from feeding point B is  $(l-x)$ , therefore, current fed from B is  $i(l-x)$ .

$$\text{Voltage drop in section BC} = \frac{i r (l-x)^2}{2} \text{ volts}$$

$$\text{Voltage at point C, } V_C = V_A - \text{Drop over AC}$$

$$= V_A - \frac{i r x^2}{2} \quad \dots(i)$$

$$\text{Also, voltage at point C, } V_C = V_B - \text{Drop over BC}$$

$$= V_B - \frac{i r (l-x)^2}{2} \quad \dots(ii)$$

From equations (i) and (ii), we get,

$$V_A - \frac{i r x^2}{2} = V_B - \frac{i r (l-x)^2}{2}$$

Solving the equation for  $x$ , we get,

$$x = \frac{V_A - V_B}{i r l} + \frac{l}{2}$$

As all the quantities on the right hand side of the equation are known, therefore, the point on the distributor where minimum potential occurs can be calculated.

### DISTRIBUTOR WITH BOTH CONCENTRATED AND UNIFORM LOADING:

There are several problems where a distributor has both concentrated and uniform loadings. In such situations, the total drop over any section of the distributor is equal to the sum of drops due to concentrated and uniform loading in that section.

### RING DISTRIBUTOR:

A distributor arranged to form a closed loop and fed at one or more points is called a ring distributor. Such a distributor starts from one point, makes a loop through the area to be served, and returns to the original point. For the purpose of calculating voltage distribution, the distributor can be considered as consisting of a series of open distributors fed at both ends. The principal advantage of ring distributor is that by proper choice in the number of feeding points, great economy in copper can be affected.

The simplest case of a ring distributor is the one having only one feeding point as shown in Fig. 13.36(ii). Here A is the feeding point and tappings are taken from points B and C. For the purpose of calculations, it is equivalent to a straight distributor fed at both ends with equal voltages.

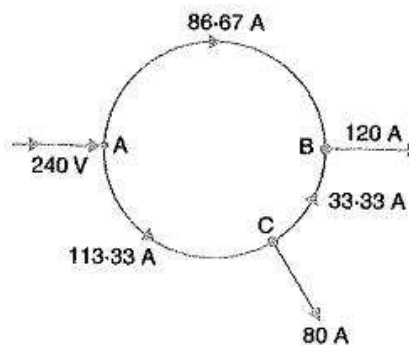

Fig. 13.36 (ii)

**RING MAIN DISTRIBUTOR WITH INTERCONNECTOR:**

Sometimes a ring distributor has to serve a large area. In such a case, voltage drops in the various sections of the distributor may become excessive. In order to reduce voltage drops in various sections, distant points of the distributor are joined through a conductor called interconnector. Fig.13.38 shows the ring distributor ABCDEA. The points B and D of the ring distributor are joined through an interconnector BD. There are several methods for solving such a network. However, the solution of such a network can be readily obtained by applying Thevenin's theorem. The steps of procedure are:

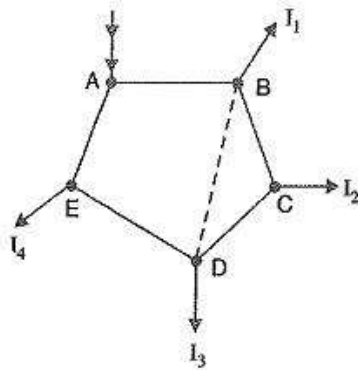

Fig. 13.38

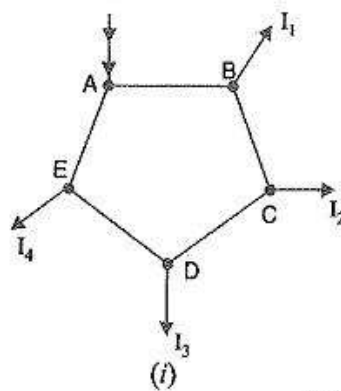
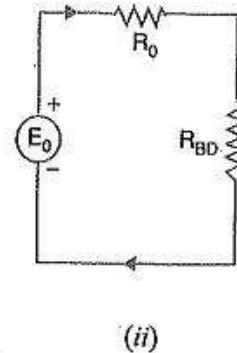

Fig. 13.39



(ii)

Consider the interconnector BD to be disconnected [See Fig. 13.39 (i)] and find the potential difference between B and D. This gives Thevenin's equivalent circuit voltage  $E_0$ . Next, calculate the resistance viewed from points B and D of the network composed of distribution lines only. This gives Thevenin's equivalent circuit series resistance  $R_0$ . If  $R_{BD}$  is the resistance of the interconnector BD, then Thevenin's equivalent circuit will be as shown in Fig. 13.39(ii).

$$\text{Current in interconnector } BD = \frac{E_0}{R_0 + R_{BD}}$$

Therefore, current distribution in each section and the voltage of load points can be calculated.

**UNIT - IV**  
**A.C DISTRIBUTION SYSTEMS**

**AC Distribution Calculations:**

AC Distribution Calculations differ from those of D.C. distribution in the following respects:

- In case of D.C. system, the voltage drop is due to resistance alone. However, in A.C. system, the voltage drops are due to the combined effects of resistance, inductance and capacitance.
- In a D.C. system, additions and subtractions of currents or voltages are done arithmetically but in case of A.C. system, these operations are done vectorially.
- In an A.C. system, power factor (p.f.) has to be taken into account. Loads tapped off from the distributor are generally at different power factors.
- There are two ways of referring power factor viz
- It may be referred to supply or receiving end voltage which is regarded as the reference
- It may be referred to the voltage at the load point itself.

There are several ways of solving AC Distribution Calculations. However, symbolic notation method has been found to be most convenient for this purpose. In this method, voltages, currents and impedances are expressed in complex notation and the calculations are made exactly as in D.C. distribution.

**Methods of Solving AC Distribution Problems:**

In AC Distribution Calculations, power factors of various load currents have to be considered since currents in different sections of the distributor will be the vector sum of load currents and not the arithmetic sum. The power factors of load currents may be given

- (i) w.r.t. receiving or sending end voltage or
- (ii) w.r.t. to load voltage itself. Each case shall be discussed separately.

(i) **Power Factors Referred To Receiving End Voltage:** Consider an a.c. distributor AB with concentrated loads of  $I_1$  and  $I_2$  tapped off at points C and B as shown in Fig. 14.1. Taking the receiving end voltage  $V_B$  as the reference vector, let lagging power factors at C and B be  $\cos \Phi_1$  and  $\cos \Phi_2$  w.r.t.  $V_B$ . Let  $R_1, X_1$  and  $R_2, X_2$  be the resistance and reactance of sections AC and CB of the distributor.

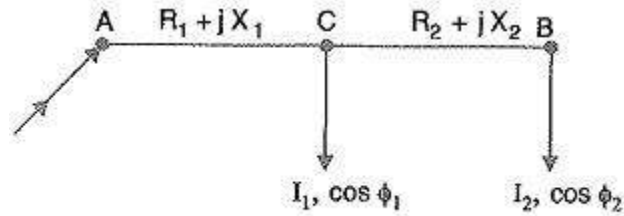

Fig. 14.1

Impedance of section AC,  $\overline{Z}_{AC} = R_1 + jX_1$

Impedance of section CB,  $\overline{Z}_{CB} = R_2 + jX_2$

Load current at point C,  $\overline{I}_1 = I_1 (\cos \phi_1 - j \sin \phi_1)$

Load current at point B,  $\overline{I}_2 = I_2 (\cos \phi_2 - j \sin \phi_2)$

Current in section CB,  $\overline{I}_{CB} = \overline{I}_2 = I_2 (\cos \phi_2 - j \sin \phi_2)$

Current in section AC,  $\overline{I}_{AC} = \overline{I}_1 + \overline{I}_2$   
 $= I_1 (\cos \phi_1 - j \sin \phi_1) + I_2 (\cos \phi_2 - j \sin \phi_2)$

Voltage drop in section CB,  $\overline{V}_{CB} = \overline{I}_{CB} \overline{Z}_{CB} = I_2 (\cos \phi_2 - j \sin \phi_2) (R_2 + jX_2)$

Voltage drop in section AC,  $\overline{V}_{AC} = \overline{I}_{AC} \overline{Z}_{AC} = (\overline{I}_1 + \overline{I}_2) \overline{Z}_{AC}$   
 $= [I_1 (\cos \phi_1 - j \sin \phi_1) + I_2 (\cos \phi_2 - j \sin \phi_2)] [R_1 + jX_1]$

Sending end voltage,  $\overline{V}_A = \overline{V}_B + \overline{V}_{CB} + \overline{V}_{AC}$

Sending end current,  $\overline{I}_A = \overline{I}_1 + \overline{I}_2$

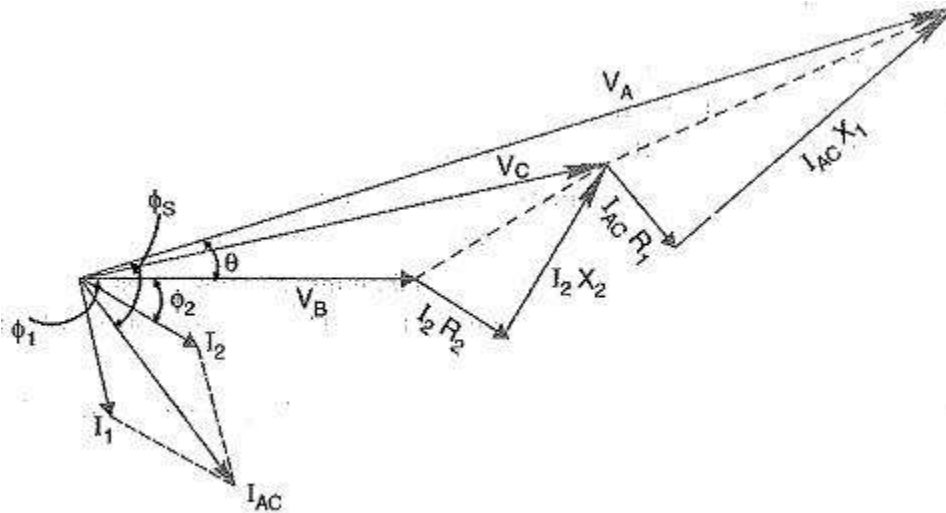

Fig. 14.2

The vector diagram of the AC Distribution Calculations under these conditions is shown in Fig. 14.2. Here, the receiving end voltage  $V_B$  is taken as the reference vector. As power factors of loads are given w.r.t.  $V_B$ , therefore,  $I_1$  and  $I_2$  lag behind  $V_B$  by  $\phi_1$  and  $\phi_2$  respectively.

(ii) **Power Factors Referred To Respective Load Voltages:** Suppose the power factors of loads in the previous Fig. 14.1 are referred to their respective load voltages. Then  $\phi_1$  is the phase angle between  $V_C$  and  $I_1$  and  $\phi_2$  is the phase angle between  $V_B$  and  $I_2$ . The vector diagram under these conditions is shown in Fig. 14.3.

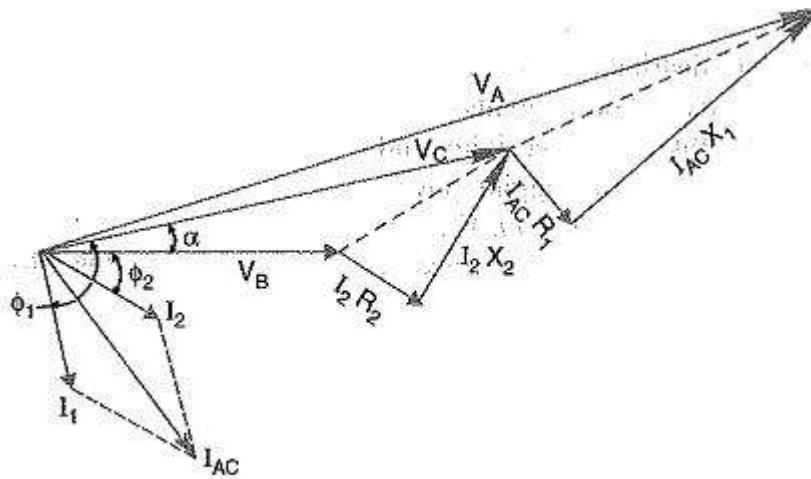

Fig. 14.3

$$\text{Voltage drop in section } CB = \vec{I}_2 \vec{Z}_{CB} = I_2 (\cos \phi_2 - j \sin \phi_2) (R_2 + j X_2)$$

$$\text{Voltage at point } C = \vec{V}_B + \text{Drop in section } CB = V_C \angle \alpha \text{ (say)}$$

$$\vec{I}_1 = I_1 \angle -\phi_1 \text{ w.r.t. voltage } V_C$$

$$\vec{I}_1 = I_1 \angle -(\phi_1 - \alpha) \text{ w.r.t. voltage } V_B$$

$$\vec{I}_1 = I_1 [\cos(\phi_1 - \alpha) - j \sin(\phi_1 - \alpha)]$$

$$\vec{I}_{AC} = \vec{I}_1 + \vec{I}_2$$

## Introduction

Power generated in power stations pass through large and complex networks like transformers, overhead lines, cables and other equipment and reaches at the end users.

It is fact that the unit of electric energy generated by Power Station does not match with the units distributed to the consumers. Some percentage of the units is lost in the distribution network.

**This difference in the generated and distributed units is known as Transmission and Distribution loss. Transmission and Distribution loss are the amounts that are not paid for by users.**

$$\text{T\&D Losses} = (\text{Energy Input to feeder(Kwh)} - \text{Billed Energy to Consumer(Kwh)}) / \text{Energy Input kwh} \times 100$$

**There are two types of Transmission and Distribution Losses:**

1. **Technical Losses**
2. **Non Technical Losses (Commercial Losses)**

### 1. Technical Losses

The technical losses are due to energy dissipated in the conductors, equipment used for transmission line, transformer, sub transmission line and distribution line and magnetic losses in transformers. Technical losses are normally **22.5%**, and directly depend on the network characteristics and the mode of operation.

The major amount of losses in a power system is in primary and secondary distribution lines. While transmission and sub-transmission lines account for only about 30% of the total losses. Therefore the primary and secondary distribution systems must be properly planned to ensure within limits.

- The unexpected load increase was reflected in the increase of technical losses above the normal level
- Losses are inherent to the distribution of electricity and cannot be eliminated.

**There are two Type of Technical Losses.****1. Permanent / Fixed Technical losses**

- Fixed losses do not vary according to current. These losses take the form of heat and noise and occur as long as a transformer is energized
- Between 1/4 and 1/3 of technical losses on distribution networks are fixed losses. Fixed losses on a network can be influenced in the ways set out below
- Corona Losses
- Leakage Current Losses
- Dielectric Losses
- Open-circuit Losses
- Losses caused by continuous load of measuring elements
- Losses caused by continuous load of control elements

**2. Variable Technical losses**

Variable losses vary with the amount of electricity distributed and are, more precisely, proportional to the square of the current. Consequently, a 1% increase in current leads to an increase in losses of more than 1%.

- Between 2/3 and 3/4 of technical (or physical) losses on distribution networks are variable Losses.
- By increasing the cross sectional area of lines and cables for a given load, losses will fall. This leads to a direct trade-off between cost of losses and cost of capital expenditure. It has been suggested that optimal average utilization rate on a distribution network that considers the cost of losses in its design could be as low as 30 per cent.
- Joule losses in lines in each voltage level
- Impedance losses
- Losses caused by contact resistance.

## Main Reasons for Technical Losses

### 1. Lengthy Distribution lines

In practically **11 KV and 415 volts lines**, in rural areas are extended over long distances to feed loads scattered over large areas. Thus the primary and secondary distributions lines in rural areas are largely radial laid usually extend over long distances.

**This results in high line resistance and therefore high  $I^2R$  losses in the line.**

- Haphazard growths of sub-transmission and distribution system in to new areas.
- Large scale rural electrification through long 11kV and LT lines.

### 2. Inadequate Size of Conductors of Distribution lines

The size of the conductors **should be selected on the basis of KVA x KM capacity of standard conductor for a required voltage regulation**, but rural loads are usually scattered and generally fed by radial feeders. The conductor size of these feeders should be adequate.

### 3. Installation of Distribution transformers away from load centers

Distribution Transformers are not located at Load center on the Secondary Distribution System.

In most of case Distribution Transformers are not located centrally with respect to consumers. Consequently, the farthest consumers obtain an extremity low voltage even though a good voltage levels maintained at the transformers secondary.

**This again leads to higher line losses.** (The reason for the line losses increasing as a result of decreased voltage at the consumers end therefore in order to reduce the voltage drop in the line to the farthest consumers, the distribution transformer should be located at the load center to keep voltage drop within permissible limits.)

### 4. Low Power Factor of Primary and secondary distribution system

In most LT distribution circuits normally the Power Factor ranges from 0.65 to 0.75. A low Power Factor contributes towards high distribution losses.

For a given load, if the Power Factor is low, the current drawn in high And the losses proportional to square of the current will be more. Thus, line losses owing to the poor PF can be reduced by improving the Power Factor.

**This can be done by application of shunt capacitors.**

- Shunt capacitors can be connected either in secondary side (11 KV side) of the 33/11 KV power transformers or at various point of Distribution Line.

- The optimum rating of capacitor banks for a distribution system is  $2/3$ rd of the average KVAR requirement of that distribution system.
- The vantage point is at  $2/3$ rd the length of the main distributor from the transformer.
- A more appropriate manner of improving this PF of the distribution system and thereby reduce the line losses is to connect capacitors across the terminals of the consumers having inductive loads.
- By connecting the capacitors across individual loads, the line loss is reduced from 4 to 9% depending upon the extent of PF improvement.

### 5. Bad Workmanship

**Bad Workmanship contributes significantly role towards increasing distribution losses.**

**Joints are a source of power loss.** Therefore the number of joints should be kept to a minimum. Proper jointing techniques should be used to ensure firm connections. Replacement of deteriorated wires and services should also be made timely to avoid any cause of leaking and loss of power.

### 6. Feeder Phase Current and Load Balancing>

**One of the easiest loss savings of the distribution system is balancing current along three-phase circuits.**

Feeder phase balancing also tends to balance voltage drop among phases giving three-phase customers less voltage unbalance. Amperage magnitude at the substation doesn't guarantee load is balanced throughout the feeder length.

**Feeder phase unbalance may vary during the day and with different seasons.** Feeders are usually considered "balanced" when phase current magnitudes are within 10. Similarly, balancing load among distribution feeders will also lower losses assuming similar conductor resistance. This may require installing additional switches between feeders to allow for appropriate load transfer.

**Bifurcation of feeders** according to Voltage regulation and Load.

### 7. Load Factor Effect on Losses

Power consumption of customer varies throughout the day and over seasons.

Residential customers generally draw their highest power demand in the evening hours. Same commercial customer load generally peak in the early afternoon. Because current level (hence,

load) is the primary driver in distribution power losses, keeping power consumption more level throughout the day will lower peak power loss and overall energy losses.

Load variation is Called load factor and It varies from 0 to 1.

**Load Factor = Average load in a specified time period / peak load during that time period.**

**For example**, for 30 days month (720 hours) peak Load of the feeder is 10 MW. If the feeder supplied a total energy of 5,000 MWh, the load factor for that month is  $(5,000 \text{ MWh}) / (10 \text{ MW} \times 720) = 0.69$ .

Lower power and energy losses are reduced by raising the load factor, which, evens out feeder demand variation throughout the feeder.

The load factor has been increase by offering customers “time-of-use” rates. Companies use pricing power to influence consumers to shift electric-intensive activities during off-peak times (such as, electric water and space heating, air conditioning, irrigating, and pool filter pumping).

With financial incentives, some electric customers are also allowing utilities to interrupt large electric loads remotely through radio frequency or power line carrier during periods of peak use. Utilities can try to design in higher load factors by running the same feeders through residential and commercial areas.

## 8. Transformer Sizing and Selection

Distribution transformers use **copper conductor windings** to induce a magnetic field into a grain-oriented silicon steel core. **Therefore, transformers have both load losses and no-load core losses.**

Transformer copper losses vary with load based on the resistive power loss equation ( $P_{\text{loss}} = I^2R$ ). For some utilities, economic transformer loading means loading distribution transformers to capacity-or slightly above capacity for a short time-in an effort to minimize capital costs and still maintain long transformer life.

However, since peak generation is usually the most expensive, **total cost of ownership (TCO)** studies should take into account the cost of peak transformer losses. Increasing distribution transformer capacity during peak by one size will often result in lower total peak power dissipation-more so if it is overloaded.

**Transformer no-load excitation loss (iron loss)** occurs from a changing magnetic field in the transformer core whenever it is energized. Core loss varies slightly with voltage but is essentially considered constant. Fixed iron loss depends on transformer core design and steel lamination molecular structure. Improved manufacturing of steel cores and introducing amorphous metals (such as metallic glass) have reduced core losses.

### 9. Balancing 3 phase loads

Balancing 3-phase loads periodically throughout a network can reduce losses significantly. It can be done relatively easily on overhead networks and consequently offers considerable scope for cost effective loss reduction, given suitable incentives.

### 10. Switching off transformers

One method of **reducing fixed losses** is to switch off transformers in periods of low demand. If two transformers of a certain size are required at a substation during peak periods, only one might be required during times of low demand so that the other transformer might be switched off in order to reduce fixed losses.

This will produce some **offsetting increase in variable losses** and might affect security and quality of supply as well as the operational condition of the transformer itself. However, these trade-offs will not be explored and optimized unless the cost of losses are taken into account.

### 11. Other Reasons for Technical Losses

- Unequal load distribution among three phases in L.T system causing high neutral currents.
- leaking and loss of power
- Over loading of lines.
- Abnormal operating conditions at which power and distribution transformers are operated
- Low voltages at consumer terminals causing higher drawl of currents by inductive loads.
- Poor quality of equipment used in agricultural pumping in rural areas, cooler air-conditioners and industrial loads in urban areas.

## **SYSTEM GROUNDING**

The process of connecting some electrical part of the power system (e.g. neutral point of a star-connected system, one conductor of the secondary of a transformer etc.) to earth (i.e. soil) is called System Grounding. The system grounding has assumed considerable importance in the fast expanding power system. By adopting proper schemes of system grounding, we can achieve many advantages including protection, reliability and safety to the power system network. But before discussing the various aspects of neutral grounding, it is desirable to give two examples to appreciate the need of system grounding. (i) Fig. 26.5 (i) shows the primary winding of a distribution transformer connected between the line and neutral of a 11 kV line. If the secondary conductors are ungrounded, it would appear that a person could touch either secondary conductor without harm because there is no ground return. However, this is not true. Referring to Fig. 26.5, there is capacitance C1 between primary and secondary and capacitance C2 between secondary

and ground. This capacitance coupling can produce a high voltage between the secondary lines and the ground.

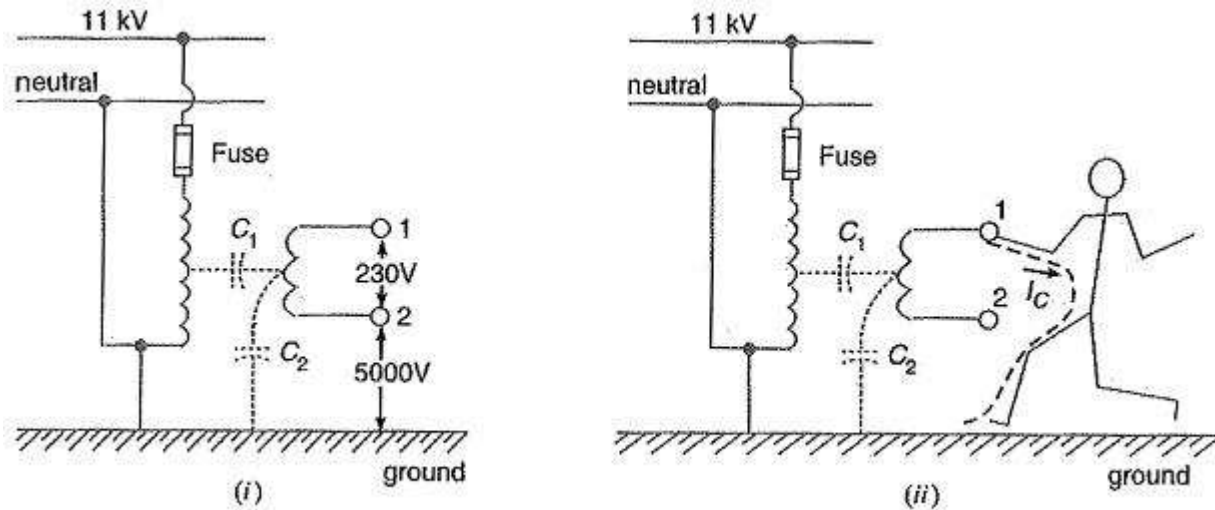

Fig. 26.5

Depending upon the relative magnitudes of  $C_1$  and  $C_2$ , it may be as high as 20% to 40% of the primary voltage. If a person touches either one of the secondary wires, the resulting capacitive current  $I_c$  flowing through the body could be dangerous even in case of small transformers [See Fig. 26.5(U)]. For example, if  $I_c$  is only 20 mA, the person may get a fatal electric shock. If one of the secondary conductors is grounded, the capacitive coupling almost reduces to zero and so is the capacitive current  $I_c$ . As a result, the person will experience no electric shock. This explains the importance of system grounding.

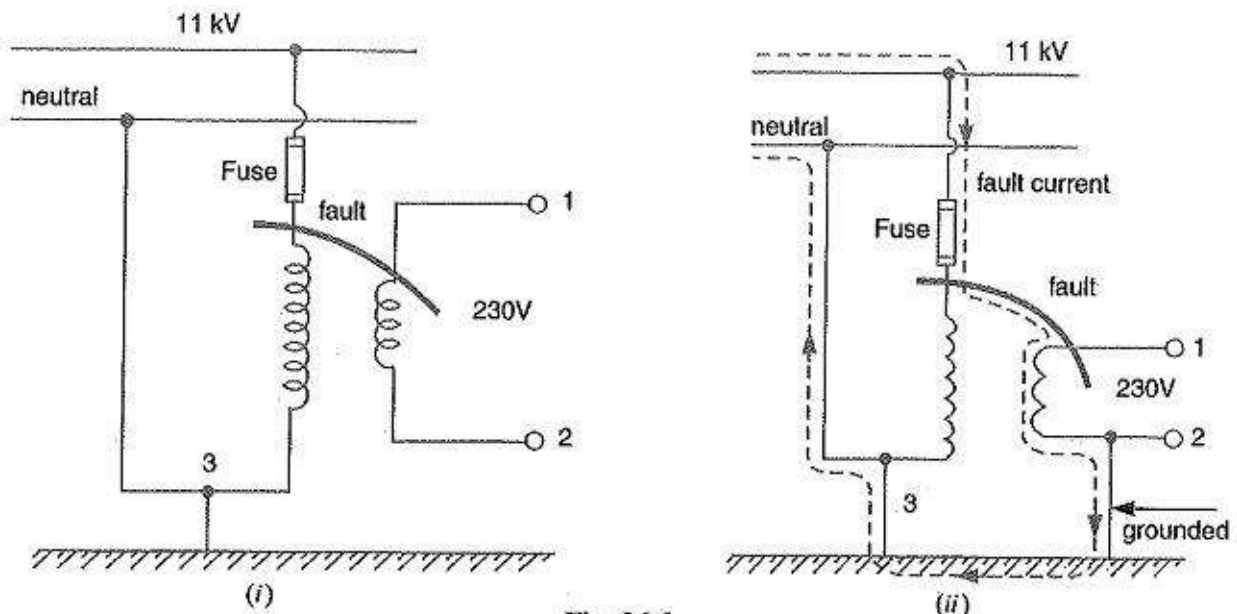

Fig. 26.6

(ii) Let us now turn to a more serious situation. Fig. 26.6 (i) shows the primary winding of a distribution transformer connected between the line and neutral of a 11 kV line. The secondary conductors are ungrounded. Suppose that the high voltage line (11 kV in this case) touches the 230 V conductor as shown in Fig. 26.6 (i). This could be caused by an internal fault in the transformer or by a branch or tree falling across the 11 kV and 230 V lines. Under these circumstances, a very high voltage is imposed between the secondary conductors and ground. This would immediately puncture the 230 V insulation, causing a Massive flashover. This flashover could occur anywhere on the secondary network, possibly inside a home or factory. Therefore, ungrounded secondary in this case is a potential fire hazard and may produce grave accidents under abnormal conditions. If one of the secondary lines is grounded as shown in Fig. 26.6(ii), the accidental contact between a 11 kV conductor and a 230 V conductor produces a dead short. The short-circuit current (Le. fault current) follows the dotted path shown in Fig. 26.6 (ii). This large current will blow the fuse on the 11 kV side, thus disconnecting the transformer and secondary distribution system from the 11 kV line. This explains the importance of system grounding in the line of the power system.

## METHODS OF NEUTRAL GROUNDING

1. Grounding - Introduction
2. Neutral Grounding - Advantages of Neutral Grounding
3. Methods of Neutral Grounding
  - (i) Solid or effective grounding
  - (ii) Resistance grounding
  - (iii) Reactance grounding
  - (iv) Peterson-coil grounding

### 1. GROUNDING - INTRODUCTION

In power system, grounding or earthing means connecting frame of electrical equipment (non-current carrying part) or some electrical part of the system (e.g. neutral point in a star-connected system, one conductor of the secondary of a transformer etc.) to earth i.e. soil. This connection to earth may be through a conductor or some other circuit element (e.g. are resistor, a circuit breaker etc.) depending up on the situation, grounding or earthing offers two principal advantages. First, it provides protection to the power system. For example, If the neutral point of a star-connected system is grounded through a circuit breaker and phase to earth fault occurs on any one line, a large fault current will flow through the circuit breaker. The circuit breaker will open to isolate the faulty line. This protects the power system from the harmful effects of the fault. Secondly, earthing of electrical equipment ensures the safety of the persons handling the

equipment. For example, if insulation fails, there will be a direct contact of the live conductor with the metallic part (i.e. frame) of the equipment. Any person in contact with the metallic part of this equipment will be subjected to a dangerous electrical shock which can be fatal. In this chapter, we shall discuss the importance of grounding or earthing in the line of power system with special emphasis on neutral grounding.

### Concept of Grounding

The process of connecting the metallic frame (i.e. non-current carrying part) of electrical equipment or some electrical part of the system (e.g. neutral point in a star-connected system, one conductor of the secondary of a transformer etc.) to earth (i.e. soil) is called grounding or earthing. It is strange but true that grounding of electrical systems is less understood aspect of power system. Nevertheless, it is a very important subject. If grounding is done systematically in the line of the power system, we can effectively prevent accidents and damage to the equipment of the power system and at the same time continuity of supply can be maintained. Grounding or earthing may be classified as:(i) Equipment grounding (ii) System grounding. Equipment grounding deals with earthing the non-current-carrying metal parts of the electrical equipment. On the other hand, system grounding means earthing some part of the electrical system e.g. earthing of neutral point of star-connected system in generating stations and substations.

### 2. Neutral Grounding

The process of connecting neutral point of 3-phase system to earth (i.e. soil) either directly or through some circuit element is called neutral grounding. Neutral grounding provides protection to personal and equipment. It is because during earth fault, the current path is completed through the earthed neutral and the protective devices (e.g. a fuse etc.) operate to isolate the faulty conductor from the rest of the system. This point is illustrated in Fig.

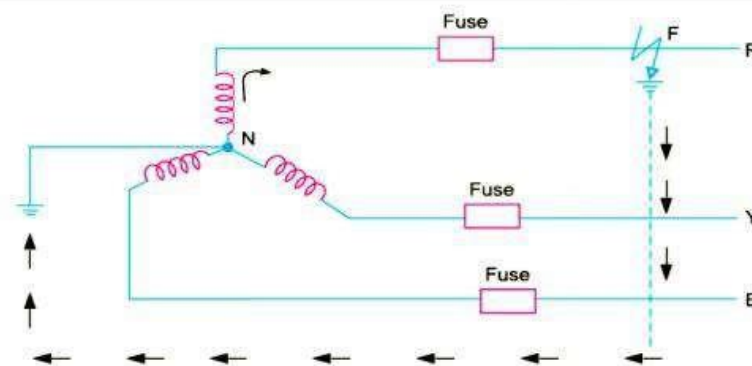

Fig. shows a 3-phase, star-connected system with neutral earthed. Suppose a single line to ground fault occurs in line R at point F. This will cause the current to flow through ground path as shown in Fig.1. Note that current flows from R phase to earth, then to neutral point N and

back to R-phase. Since the impedance of the current path is low, a large current flows through this path. This large current will blow the fuse in R-phase and isolate the faulty line R. This will protect the system from the harmful effects of the fault. One important feature of grounded neutral is that the potential difference between the live conductor and ground will not exceed the phase voltage of the system i.e. it will remain nearly constant.

### Advantages of Neutral Grounding

The following are the advantages of neutral grounding

- (i) Voltages of the healthy phases do not exceed line to ground voltages i.e. they remain nearly constant.
- (ii) The high voltages due to arcing grounds are eliminated.
- (iii) The protective relays can be used to provide protection against earth faults. In case earth fault occurs on any line, the protective relay will operate to isolate the faulty line.
- (iv) The over voltages due to lightning are discharged to earth.
- (v) It provides greater safety to personnel and equipment.
- (vi) It provides improved service reliability.
- (vii) Operating and maintenance expenditures are reduced

### 3. Methods of Neutral Grounding

The methods commonly used for grounding the neutral point of a 3-phase system are:

- (i) Solid or effective grounding
- (ii) Resistance grounding
- (iii) Reactance grounding
- (iv) Peterson-coil grounding

The choice of the method of grounding depends upon many factors including the size of the system, system voltage and the scheme of protection to be used.

#### (i) Solid Grounding

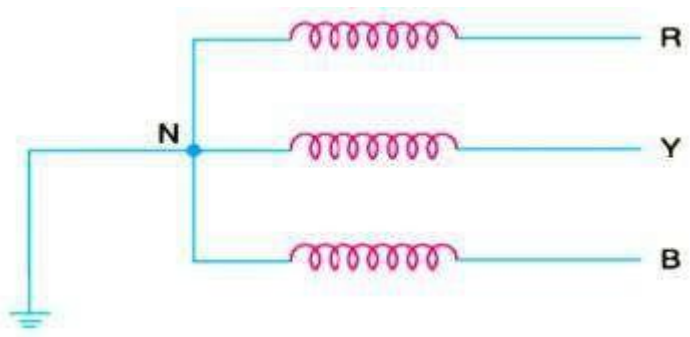

When the neutral point of a 3-phase system (e.g. 3-phase generator, 3-phase transformer etc.) is directly connected to earth (i.e. soil) through a wire of negligible resistance and reactance, it is

called solid grounding or effective grounding. Fig. shows the solid grounding of the neutral point. Since the neutral point is directly connected to earth through a wire, the neutral point is held at earth potential under all conditions. Therefore, under fault conditions, the voltage of any conductor to earth will not exceed the normal phase voltage of the system.

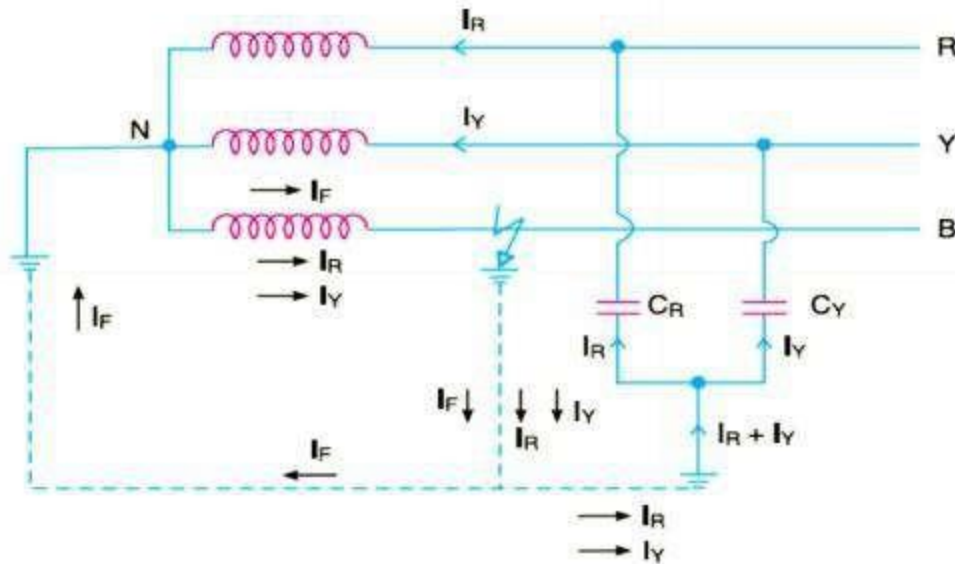

### Advantages

The solid grounding of neutral point has the following advantages:

(i) The neutral is effectively held at earth potential.

(ii) When earth fault occurs on any phase, the resultant capacitive current  $I_C$  is in phase opposition to the fault current  $I_F$ . The two currents completely cancel each other. Therefore, no arcing ground or over-voltage conditions can occur. Consider a line to ground fault in line B as shown in Fig. The capacitive currents flowing in the healthy phases R and Y are  $I_R$  and  $I_Y$  respectively. The resultant capacitive current  $I_C$  is the phasor sum of  $I_R$  and  $I_Y$ . In addition to these capacitive currents, the power source also supplies the fault current  $I_F$ . This fault current will go from fault point to earth, then to neutral point N and back to the fault point through the faulty phase. The path of  $I_C$  is capacitive and that of  $I_F$  is inductive. The two currents are in phase opposition and completely cancel each other. Therefore, no arcing ground phenomenon or over-voltage conditions can occur.

(iii) When there is an earth fault on any phase of the system, the phase to earth voltage of the faulty phase becomes zero. However, the phase to earth voltages of the remaining two healthy phases remain at normal phase voltage because the potential of the neutral is fixed at earth potential. This permits to insulate the equipment for phase voltage. Therefore, there is a saving in the cost of equipment.

(iv) It becomes easier to protect the system from earth faults which frequently occur on the system. When there is an earth fault on any phase of the system, large fault current flows between the fault point and the grounded neutral. This permits the easy operation of earth fault relay.

### Disadvantages

The following are the disadvantages of solid grounding :

- (i) Since most of the faults on an overhead system are phase to earth faults, the system has to bear a large number of severe shocks. This causes the system to become unstable.
- (ii) The solid grounding results in heavy earth fault currents. Since the fault has to be cleared by the circuit breakers, the heavy earth fault currents may cause the burning of circuit breaker contacts.
- (iii) The increased earth fault current results in greater interference in the neighboring communication lines.

### Applications

Solid grounding is usually employed where the circuit impedance is sufficiently high so as to keep the earth fault current within safe limits. This system of grounding is used for voltages up to 33 kV with total power capacity not exceeding 5000 kVA.

### (ii) Resistance Grounding

In order to limit the magnitude of earth fault current, it is a common practice to connect the neutral point of a 3-phase system to earth through a resistor. This is called resistance grounding. When the neutral point of a 3-phase system (e.g. 3-phase generator, 3-phase transformer etc.) is connected to earth (i.e. soil) through a resistor, it is called resistance grounding. Fig.shows the grounding of neutral point through a resistor  $R$  . The value of  $R$  should neither be very low nor very high. If the value of earthing resistance  $R$  is very low, the earth fault current will be large and the system becomes similar to the solid grounding system.

On the other hand, if the earthing resistance  $R$  is very high, the system conditions become similar to ungrounded neutral system. The value of  $R$  is so chosen such that the earth fault

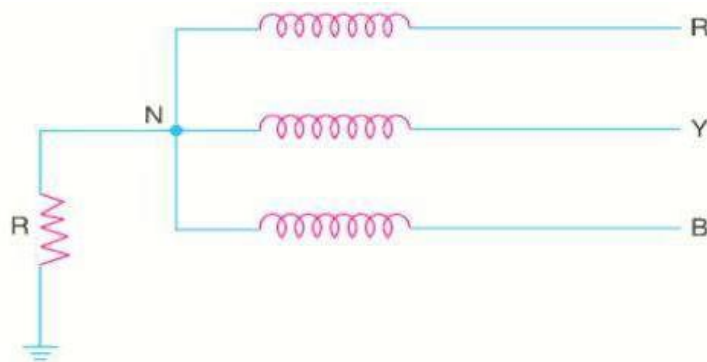

current is limited to safe value but still sufficient to permit the operation of earth fault protection system. In practice, that value of  $R$  is selected that limits the earth fault current to 2 times the normal full load current of the earthed generator or transformer.

### Advantages

The following are the advantages of resistance earthing:

- i) The earth fault current is small due to the presence of earthing resistance. Therefore, interference with communication circuits is reduced.
- ii) It improves the stability of the system.

### Disadvantages

The following are the disadvantages of resistance grounding :

- (i) Since the system neutral is displaced during earth faults, the equipment has to be insulated for higher voltages.
- (ii) This system is costlier than the solidly grounded system.
- (iii) A large amount of energy is produced in the earthing resistance during earth faults. Sometimes it becomes difficult to dissipate this energy to atmosphere.

### Applications

It is used on a system operating at voltages between 2.2 kV and 33 kV with power source capacity more than 5000 kVA.

### (iii) Reactance Grounding

In this system, a reactance is inserted between the neutral and ground as shown in Fig. The purpose of reactance is to limit the earth fault current. By changing the earthing reactance, the earth fault current can be changed to obtain the conditions similar to that of solid grounding. This method is not used these days because of the following

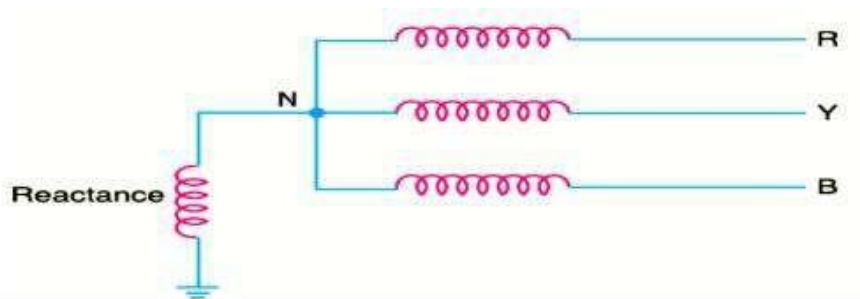

### Disadvantages

- (i) In this system, the fault current required to operate the protective device is higher than that of resistance grounding for the same fault conditions.
- (ii) High transient voltages appear under fault conditions.

#### (IV) Arc Suspension Grounding (Or Resonant Grounding)

We have seen that capacitive currents are responsible for producing arcing grounds. These capacitive currents flow because capacitance exists between each line and earth. If inductance  $L$  of appropriate value is connected in parallel with the capacitance of the system, the fault current  $I_F$  flowing through  $L$  will be in phase opposition to the capacitive current  $I_C$  of the system. If  $L$  is so adjusted that  $I_L = I_C$  then resultant current in the fault will be zero. This condition is known as resonant grounding. When the value of  $L$  of arc suppression coil is such that the fault current  $I_F$  exactly balances the capacitive current  $I_C$ , it is called resonant grounding

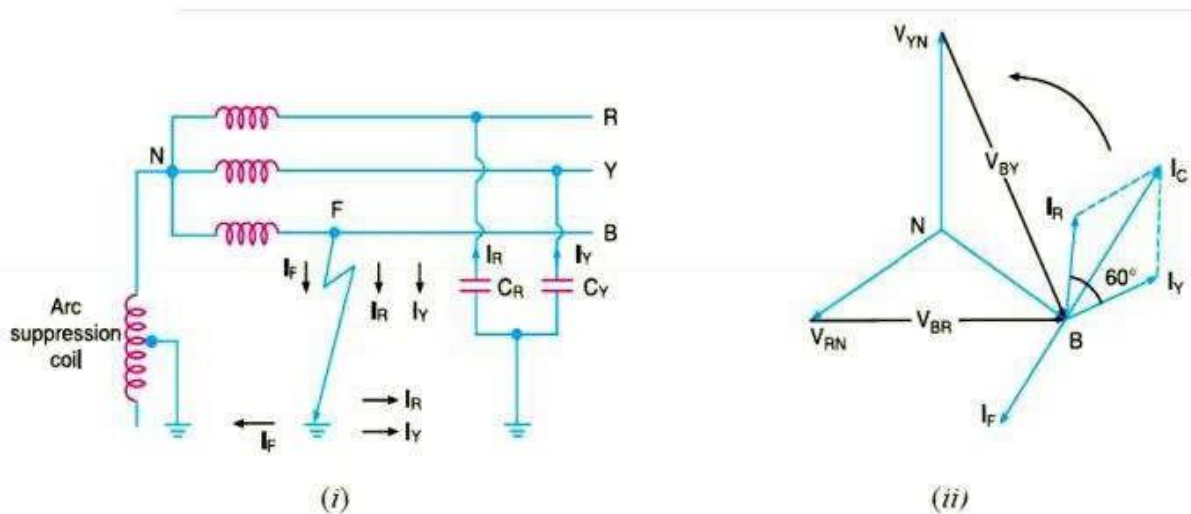

Value of  $L$  for resonant grounding . For resonant grounding, the system behaves as an ungrounded neutral system. Therefore, full line voltage appears across capacitors  $C_R$  and  $C_Y$

$$\therefore I_R = I_Y = \frac{\sqrt{3}V_{ph}}{X_C}$$

$$\therefore I_C = \sqrt{3}I_R = \sqrt{3} \times \frac{\sqrt{3}V_{ph}}{X_C} = \frac{3V_{ph}}{X_C}$$

Here,  $X_C$  is the line to ground capacitive reactance.

Fault current, 
$$I_F = \frac{V_{ph}}{X_L}$$

Here,  $X_L$  is the inductive reactance of the arc suppression coil.

For resonant grounding,  $I_L = I_C$ .

or 
$$\frac{V_{ph}}{X_L} = \frac{3V_{ph}}{X_C}$$

or 
$$X_L = \frac{X_C}{3}$$

or 
$$\omega L = \frac{1}{3\omega C}$$

$\therefore$  
$$L = \frac{1}{3\omega^2 C} \quad \dots(i)$$

Exp. (i) gives the value of inductance L of the arc suppression coil for resonant grounding.

### Advantages

The Peterson coil grounding has the following advantages:

- (i) The Peterson coil is completely effective in preventing any damage by an arcing ground.
- (ii) The Peterson coil has the advantages of ungrounded neutral system.

### Disadvantages

The Peterson coil grounding has the following disadvantages:

- (i) Due to varying operational conditions, the capacitance of the network changes from time to time. Therefore, inductance L of Peterson coil requires readjustment.
- (ii) The lines should be transposed.

## **UNIT - V** **SUBSTATIONS**

### **SUBSTATION:**

The assembly of apparatus used to change some characteristic (e.g. voltage, ac. to dc. frequency, p.f. etc.) of electric supply is called a Substation. Sub-stations are important part of power system. The continuity of supply depends to a considerable extent upon the successful operation of sub-stations. It is, therefore, essential to exercise utmost care while designing and building a sub-station. The following are the important points which must be kept in view while laying out a sub-station :

- It should be located at a proper site. As far as possible, it should be located at the centre of gravity of load. It should provide safe and reliable arrangement.
- For safety, consideration must be given to the maintenance of regulation clearances, facilities for carrying out repairs and maintenance, abnormal occurrences such as possibility of explosion or fire etc.
- For reliability, consideration must be given for good design and construction, the provision of suitable protective gear It should be easily operated and maintained.
- It should involve minimum capital cost.

### **CLASSIFICATION OF SUBSTATION:**

There are several ways of classifying sub-stations. However, the two most important ways of classifying them are according to

- **Service requirement and**
- **Constructional features.**

1. According to service requirement: A sub-station may be called upon to change voltage level or improve power factor or convert A.C. power into D.C. power etc.

According to the service requirement, sub-stations may be classified into:

- (i) **Transformer sub-stations:** Those sub-stations which change the voltage level of electric supply are called transformer sub-stations. These sub-stations receive power at some voltage and deliver it at some other voltage. Obviously, transformer will be the main component in such sub Most of the sub-stations in the power system are of this type.
- (ii) **Switching sub-stations:** These sub-stations do not change the voltage level i.e. incoming and outgoing lines have the same voltage. However; they simply perform the switching operations of power lines.
- (iii) **Power factor correction sub-stations:** Those sub-stations which improve the power factor of the system are called power factor correction sub-stations. Such sub-stations are generally

located at the receiving end of transmission lines. These sub-stations generally use synchronous condensers as the power factor improvement equipment.

- (iv) Frequency changer sub-stations: Those sub-stations which change the supply frequency are known as frequency changer sub-stations. Such a frequency change may be required for industrial utilization.
- (v) Converting sub-stations: Those sub-stations which change A.C. power into D.C. power are called converting sub-stations. These sub-stations receive ac. power and convert it into D.C. power with suitable apparatus (e.g. ignitron) to supply for such purposes as traction, electroplating, electric welding etc.
- (vi) Industrial sub-stations: Those sub-stations which supply power to individual industrial concerns are known as industrial sub-stations.

2. According to constructional features:

A sub-station has many components (e.g. circuit breakers, switches, fuses, instruments etc.) which must be housed properly to ensure continuous and reliable service

According to constructional features, the sub-stations are classified as :

- Indoor sub-station
- Outdoor sub-station
- Underground sub-station
- Pole-mounted sub-station

**1. Indoor sub-stations:**

For voltages upto 11 kV, the equipment of the sub-station is installed indoor because of economic considerations. However, when the atmosphere is contaminated with impurities, these sub-stations can be erected for voltages upto 66 kV.

**2. Outdoor sub-stations:**

For voltages beyond 66 kV, equipment is invariably installed out It is because for such voltages, the clearances between conductors and the space required for switches, circuit breakers and other equipment becomes so great that it is not economical to install the equipment indoor.

**3. Underground sub-stations:**

In thickly populated areas, the space available for equipment and building is limited and the cost of land is high. Under such situations, the sub-station is created The reader may find further discussion on underground sub-stations.

#### 4 Pole-mounted sub-stations:

This is an outdoor sub-station with equipment installed overhead on H-pole or 4-pole structure. It is the cheapest form of sub-station for voltages not exceeding 11 kV (or 33 kV in some cases). Electric power is almost distributed in localities through such sub for complete discussion on pole-mounted sub-station.

Comparison between Outdoor and Indoor SubStation:

The comparison between outdoor and indoor sub-stations is given below in the tabular form:

S.No.	Particular	Outdoor Sub-station	Indoor Sub-station
1	Space required	More	Less
2	Time required for erection	Less	More
3	Future extension	Easy	Difficult
4	Fault location	Easier because the equipment is in full view	Difficult because the equipment is enclosed
5	Capital cost	Low	High
6	Operation	Difficult	Easier
7	Possibility of fault escalation	Less because greater clearances can be provided	More

From the above comparison, it is clear that each type has its own advantages and disadvantages. However, comparative economics (i.e. annual cost of operation) is the most powerful factor influencing the choice between indoor and outdoor sub-stations. The greater cost of indoor sub-station prohibits its use. But sometimes non-economic factors (e.g. public safety) exert considerable influence in choosing indoor sub-station. In general, most of the sub-stations are of outdoor type and the indoor sub-stations are erected only where outdoor construction is impracticable or prohibited by the local laws.

### **Air Insulated Substation (AIS)**

The AIS uses air as the primary dielectric from phase to phase, and phase to ground insulation. They have been in use for years before the introduction of GIS.

Actually, most substations across all regions are AIS. They are in extensive use in areas where space, weather conditions, seismic occurrences, and environmental concerns are not an issue such as rural areas, and favourable offsite terrain.

The indoor AIS version is only used in highly polluted areas, and saline conditions, as the air quality is compromised.



#### **Advantages**

1. The primary choice for areas with extensive space
2. With quality design, the system is viable due to the low construction costs and cost of switchgear
3. Less construction time, thereby more suited for expedited installations
4. Easy maintenance as all the equipment is within view. It is easy to notice and attend to faults.

#### **Disadvantages**

1. More space is required compared to GIS
2. Vulnerable to faults since the equipment are exposed to the external elements such as human intrusion, pollution, deposition of saline particles, lightning strikes and extreme weather conditions
3. More maintenance requirements, thus leading to high costs
4. The poor dielectric properties of air, as well as secondary factors such as humidity, pollutants, moisture means that more space is required for efficiency.

**SUBSTATION LAYOUT****➤ Substation Layout AIS****AIS Substation Description**

An Air Insulated Switchgear substation (AIS substation) uses atmospheric air as the phase to ground insulation for the switchgear of an electrical substation. The main advantage of the AIS substation is the scope of the substation for future offloading, for this reason AIS substations tend to be the most popular 400kV substation type. The equipment of an AIS substation is easily sourced and has a short lead-time; this means that the required future offloading does not need to be built immediately, unlike GIS where it must be considered. The main disadvantage to the AIS substation is its overall size. At 400kV level these substations can have a significant footprint and require sensitive locating in any rural environment. AIS are usually installed outdoor.

**AIS Substation Size**

Based on the single line diagrams given in Appendix B the minimum size of an AIS substation for this project would be as follows:

1. Overall substation Compound Size 46,864.5m<sup>2</sup>(235.5m x 199m or approximately 11.6 acres)
2. Height of highest element of substation ~ 28m (lightning protection structures situated in the substation compound)

Note: The switchgear in an AIS substation is outdoors therefore no building sizes are considered.

**AIS Maintenance Requirements**

1. Ongoing maintenance requirements, all equipment exposed to weather conditions
2. Disconnect contacts must be cleaned regularly, operating mechanisms must be checked and maintained

**INDOOR AND OUTDOOR SUBSTATIONS*****INDOOR SUBSTATIONS:***

In these substations, the apparatus is installed within the substation building. Such substations are usually for a voltage up to 11,000 V but can be erected for 33,000 V and 66,000 volts when the surrounding atmosphere is contaminated with impurities such as metal corroding gases and fumes, conductive dust etc. The switchgear on supply or primary side will consist of oil circuit breakers only.

The high voltage supply is given to the primary of the transformer through circuit breaker. From the bus-bar various feeders emerge out. The panel for each feeder consists of an isolator switch and circuit breaker. In addition to isolator and circuit breaker, the panel is provided with the measuring instruments. As regards protection of feeders usually reverse power relay is employed. For the protection of oil filled transformers with conservator tanks Buchholz's relay is most common.

**The auxiliaries of the indoor type of substations are:**

- (i) Storage batteries,
- (ii) Fire-fighting equipment such as water buckets, fire extinguishers, etc.

**The batteries are used for the:**

- (i) Operation of the protective gear and switch operating solenoids, and
- (ii) Emergency lighting in substations in case of failure of supply.

The several compartments in which the indoor substation is divided are control compartment, indicating and metering instruments and protective device compartment, circuit breaker and operating mechanism compartment, main bus-bar compartment and current transformer and cable sealing box compartment.

Indoor distribution and transformer substations as well as high voltage switchboards consist of a series of open and enclosed chambers or compartments. The main equipment of the given installation is arranged in these compartments. The chamber space, within which the equipment of any one main bus-bar connection is mounted, as a whole, is called as a cell, cubicle or compartment.

**According to construction indoor distribution transformer substations and high voltage switchboards are further subdivided into the following categories:**

**1. Substations of the Integrally Built Type:**

It is that in which the apparatus is installed on site. In such substations the cell structures are constructed of concrete or bricks.

**2. Substations of the Composite Built-Up Type:**

It is that type in which the assemblies and parts are factory or workshop prefabricated, but is assembled on site within a substation switchgear room. The compartments of such substations take form of metal cabinets or enclosures, each of which contains the equipment of one main connection cell. Within such cabinets or enclosures an oil minimum circuit breaker, a load-interrupter switch and one or more voltage transformers may be mounted.

**3. Unit Type Factory Fabricated Substations and Metal Clad Switchboards:**

These are built in electrical workshops and are shipped to the site of installations fully pre-assembled. After installations of substations and switchboards only connection to the incoming and outgoing power circuits are required to be made. Cubicles for unit type switchboards or substations take the form of fully enclosed metal clad cabinets.

Metal clad cubicles designed with withdrawable trucks and divided into several compartments are usually employed. The several compartments in which the cubicle is divided are control compartment, indicating and metering instrument and protective device compartment, circuit breaker and operating mechanism compartment, main bus-bar compartment and current transformers and cable sealing box compartment.

By partitioning of the cubicle space into compartments safe access to the apparatus is provided. The circuit breaker and its operating mechanism are mounted on the truck, which can be withdrawn from the cubicle. In withdrawable-truck unit-type cubicles the isolating device is of the plug-in-type.

When the truck is rolled out from the cubicle the holes in which the isolating devices enter for making contacts are automatically closed by metal shutters serving to isolate the live parts from possible casual contact. When the truck is rolled back into the cubicle, the shutters open automatically.

To prevent any possible opening or closing of the disconnecting devices when the circuit breaker is closed, these cubicles are designed with interlocks which prevent the truck from being rolled in or withdrawn when the circuit breaker is closed.

***OUTDOOR SUBSTATIONS:***

**Outdoor substations are of two types namely:**

1. Pole-mounted substations, and
2. Foundation-mounted substations.

**1. Pole-Mounted Substations:**

Such substations are erected for mounting distribution transformers of capacity up to 250 kVA. Such substations are cheapest, simple and smallest of substations. All the equipment is of outdoor type and mounted on the supporting structure of ht distribution line. Triple Pole Mechanically Operated (TPMO) switch is used for switching “on” and “off” of ht transmission line. HT fuse unit is installed for protection of ht side.

To control ht side iron clad low tension switch of suitable capacity with fuses is installed. Lightning arresters are installed over the ht line to protect the transformer from the surges. Substation is earthed at two or more places.

Generally a transformer of capacity up to 125 kVA are mounted on double pole structure and for transformers of capacity above 125 kVA but not exceeding 250 kVA 4-pole structures with suitable platform is used. This type of pole-mounted substation is erected in very thickly populated location.

The maintenance cost of such substations is low and by using a large number of such substations in a town it is possible to lay the distributors, at a lower cost. But owing to increase in number of transformers, total kVA is increased, no load losses increase and the cost per kVA is thus more. Economy is the main consideration when a choice is made for such substations.

**2. Foundation Mounted Substations:**

These substations are built entirely in the open and in such substations all the equipment is assembled into one unit usually enclosed by a fence from the point of view of safety. Substations for primary and secondary transmission and for secondary distribution, (above 250 kVA) are foundation mounted outdoor type. Since equipment required for such substations is heavy, therefore, site selected for these substations must have a good access for heavy transport.

Again, owing to exposed bus-bars and other associated equipment the clearances and spacings are not only to be governed by the operating voltage but also from the considerations of the encroachment from outside. Low level types of substations are designed except when the space available is limited as these provide facility of easy inspection, cleaning and maintenance.

The switchgear consists of circuit breakers of suitable type on both the sides but with the increased reliability of the modern transformers, the practice is to dispense with the circuit breaker on the incoming side from the economic consideration. The isolating switches thus serve the purpose.

**Advantages and Disadvantages of Outdoor Substations over Indoor Substations:**

**The outdoor substations have the following main advantages over indoor substations:**

- (i) All the equipment is within view and therefore fault location is easier.
- (ii) The extension of the installation is easier, if required.
- (iii) The time required in erection of such substations is lesser.
- (iv) The smaller amount of building materials (steel-concrete) is required.
- (v) The construction work required is comparatively smaller and cost of the switchgear installation is low.
- (vi) There is practically no danger of a fault which appears at one point being carried over to another point in the installation because the apparatus of the adjoining connections can be spaced liberally, without any appreciable increase in costs.
- (vii) Repairing work is easy.

**The disadvantages of outdoor installations in comparison of indoor installations are:**

- (i) The various switching operations with the isolators, as well as supervision and maintenance of the apparatus are to be performed in the open air during all kinds of weather.
- (ii) More space is required for the substation.
- (iii) Protection devices are required to be installed for protection against lightning surges.
- (iv) The length of control cables required is more.
- (v) The influence of rapid fluctuation in ambient temperature and dust and dirt deposits upon the outdoor substation equipment makes it necessary to install apparatus specially designed for outdoor service and, therefore, more costly.

Notwithstanding the disadvantages, outdoor substations are very widely used in power systems.

**COMPONENTS OF SUB-STATIONS:**

Besides the transformers, the several other equipment include

- Bus bars
- Circuit Breakers
- Isolators
- Surge Arresters
- Substation Earthing system
- Current Transformers
- Voltage Transformers
- Shunt Reactors
- Shunt Capacitors etc.

Each equipment has certain functional requirement.

**BUSBARS**

Bus bars are conducting bars to which number of circuit connections is connected. Bus-bars are copper or aluminum bars (generally of rectangular  $x$ -section) and operate at constant voltage. The incoming and outgoing lines in a sub-station are connected to the bus-bars. The most commonly used bus-bar arrangements in sub-stations are :

- (i) Single bus-bar arrangement
- (ii) Single bus-bar system with sectionalisation
- (iii) Double bus-bar arrangement

**INSULATORS:**

The insulators serve two purposes. They support the conductors (or bus-bars) and confine the current to the conductors. The most commonly used material for the manufacture of insulators is porcelain. There are several types of insulators (*e.g.* pin type, suspension type, post insulator etc.) and their use in the sub-station will depend upon the service requirement. For example, post insulator is used for bus-bars. A post insulator consists of a porcelain body, cast iron cap and flanged cast iron base. The hole in the cap is threaded so that bus-bars can be directly bolted to the cap.

**ISOLATING SWITCHES:**

In sub-stations, it is often desired to disconnect a part of the system for general maintenance and repairs. This is accomplished by an isolating switch or isolator. An isolator is essentially a knife switch and is designed to open a circuit under *no load*. In other words, isolator switches are operated only when the lines in which they are connected carry \*no current.

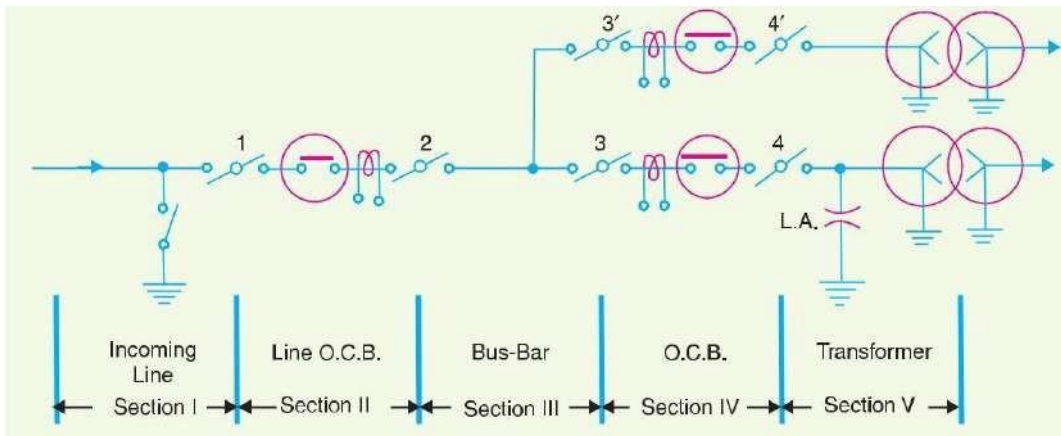

The entire sub-station has been divided into V sections. Each section can be disconnected with the help of isolators for repair and maintenance. For instance, if it is desired to repair section No. II, the procedure of disconnecting this section will be as follows. First of all, open the circuit breaker in this section and then open the isolators 1 and 2. This procedure will disconnect section II for repairs. After the repair has been done, close the isolators 1 and 2 first and then the circuit breaker.

### **CIRCUIT BREAKER:**

A circuit breaker is equipment which can open or close a circuit under normal as well as fault conditions. It is so designed that it can be operated manually (or by remote control) under normal conditions and automatically under fault conditions. For the latter operation, a relay circuit is used with a circuit breaker. Generally, bulk oil circuit breakers are used for voltages upto 66kV while for high (>66 kV) voltages, low oil circuit breakers are used. For still higher

### **POWER TRANSFORMERS:**

A power transformer is used in sub-station to step-up or step-down the voltage. Except at the power station, all the subsequent sub-stations use step-down transformers to gradually reduce the voltage of electric supply and finally deliver it at utilisation voltage. The modern practice is to use 3-phase transformers in sub-stations ; although 3 single phase bank of transformers can also be used. The use of 3-phase transformer (instead of 3 single phase bank of transformers) permits two advantages. Firstly, only one 3-phase load-tap changing mechanism can be used. Secondly, its installation is much simpler than the three single phase transformers. The power transformer is generally installed upon lengths of rails fixed on concrete slabs having foundations 1 to 1.5 m deep. For ratings upto 10 MVA, naturally cooled, oil immersed transformers are used. For higher ratings, the transformers are generally air blast cooled.

**INSTRUMENT TRANSFORMERS:**

The lines in sub-stations operate at high voltages and carry current of thousands of amperes. The measuring instruments and protective devices are designed for low voltages (generally 110 V) and currents (about 5 A). Therefore, they will not work satisfactorily if mounted directly on the power lines. This difficulty is overcome by installing *instrument transformers* on the power lines. The function of these instrument transformers is to transfer voltages or currents in the power lines to values which are convenient for the operation of measuring instruments and relays.

There are two types of instrument transformers *viz.*

- (i) Current transformer (C.T.)
- (ii) Potential transformer (P.T.)

**(i) Current transformer (C.T.):**

A current transformer is essentially a step-up transformer which steps down the current to a known ratio. The primary of this transformer consists of one or more turns of thick wire connected in series with the line. The secondary consists of a large number of turns of fine wire and provides for the measuring instruments and relays a current which is a constant fraction of the current in the line. Suppose a current transformer rated at 100/5 A is connected in the line to measure current. If the current in the line is 100 A, then current in the secondary will be 5A. Similarly, if current in the line is 50A, then secondary of C.T. will have a current of 2.5 A. Thus the C.T. under consideration will step down the line current by a factor of 20.

**(ii) Voltage transformer:**

It is essentially a step down transformer and steps down the voltage to a known ratio. The primary of this transformer consists of a large number of turns of fine wire connected across the line. The secondary winding consists of a few turns and provides for measuring instruments and relays a voltage which is a known fraction of the line voltage. Suppose a potential transformer rated at 66kV/110V is connected to a power line. If line voltage is 66kV, then voltage across the secondary will be 110 V.

**Metering and Indicating Instruments:**

There are several metering and indicating instruments (*e.g.* ammeters, voltmeters, energy meters etc.) installed in a sub-station to maintain watch over the circuit quantities. The instrument transformers are invariably used with them for satisfactory operation.

**Miscellaneous equipment.**

In addition to above, there may be following equipment in a substation:

- Fuses
- carrier-current equipment
- sub-station auxiliary supplies

### BUSBAR ARRANGEMENTS IN SUBSTATIONS:

Busbar are the important components in a sub-station. There are several Busbar Arrangements in Substations that can be used in a sub-station. The choice of a particular arrangement depends upon various factors such as system voltage, position of sub-station, degree of reliability, cost etc.

The following are the important bus-bar arrangements used in sub-stations:

#### (i) Single bus-bar system:

As the name suggests, it consists of a single bus-bar and all the incoming and outgoing lines are connected to it. The chief advantages of this type of arrangement are low initial cost, less maintenance and simple operation. However, the principal disadvantage of single bus-bar system is that if repair is to be done on the bus-bar or a fault occurs on the bus, there is a complete interruption of the supply. This arrangement is not used for voltages exceeding 33kV. The indoor 11kV sub-stations often use single Busbar Arrangements in Substations.

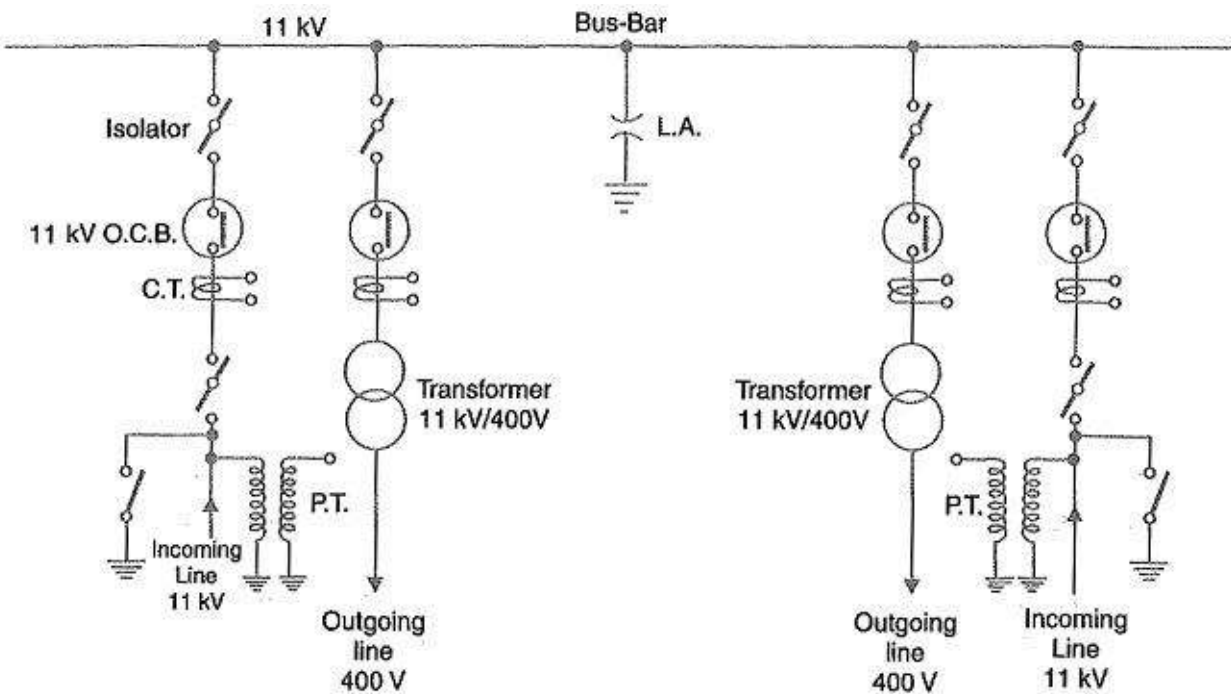

Fig. 25.5

Fig. 25.5 shows single Busbar Arrangements in Substations. There are two 11 kV incoming lines connected to the bus-bar through circuit breakers and isolators. The two 400V outgoing lines are connected to the bus bars through transformers (11kV/400 V) and circuit breakers.

**(ii) Single bus-bar system with sectionalisation:**

In this arrangement, the single bus-bar is divided into sections and load is equally distributed on all the sections. Any two sections of the bus-bar are connected by a circuit breaker and isolators. Two principal advantages are claimed for this arrangement. Firstly, if a fault occurs on any section of the bus, that section can be isolated without affecting the supply from other sections. Secondly, repairs and maintenance of any section of the bus-bar can be carried out by de-energising that section only, eliminating the possibility of complete shut down. This arrangement is used for voltages upto 33 kV.

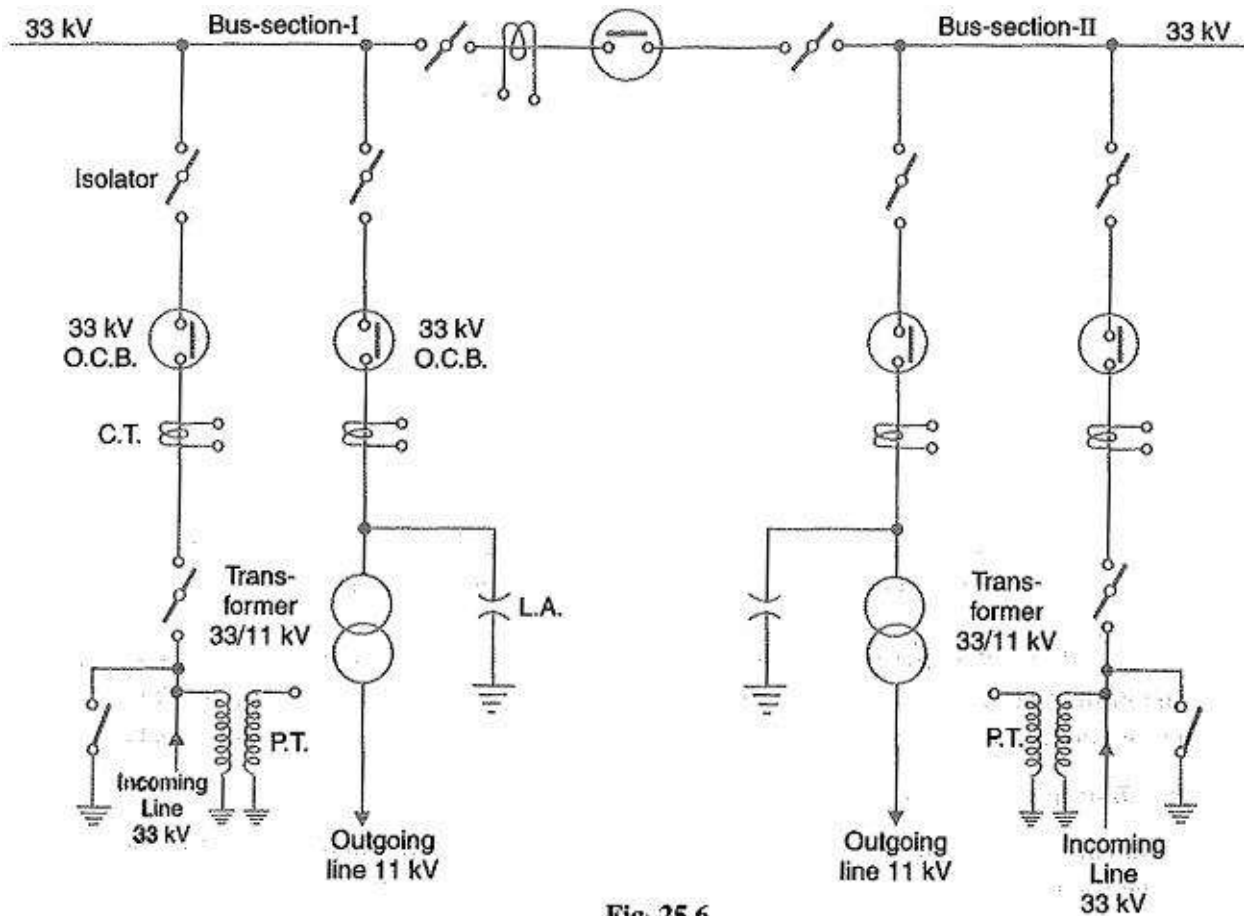

Fig. 25.6 shows bus-bar with sectionalisation where the bus has been divided into two sections. There are two 33 kV incoming lines connected to sections I and II as shown through circuit breaker and isolators. Each 11 kV outgoing line is connected to one section through transformer (33/11 kV) and circuit breaker. It is easy to see that each bus-section behaves as a separate bus-bar.

### (iii) Duplicate bus-bar system:

This system consists of two bus-bars, a “main” bus-bar and a “spare” bus-bar. Each bus-bar has the capacity to take up the entire sub-station load. The incoming and outgoing lines can be connected to either bus-bar with the help of a bus-bar coupler which consists of a circuit breaker and isolators. Ordinarily, the incoming and outgoing lines remain connected to the main bus-bar. However, in case of repair of main bus-bar or fault occurring on it, the continuity of supply to the circuit can be maintained by transferring it to the spare bus-bar. For voltages exceeding 33kV, duplicate bus-bar system is frequently used.

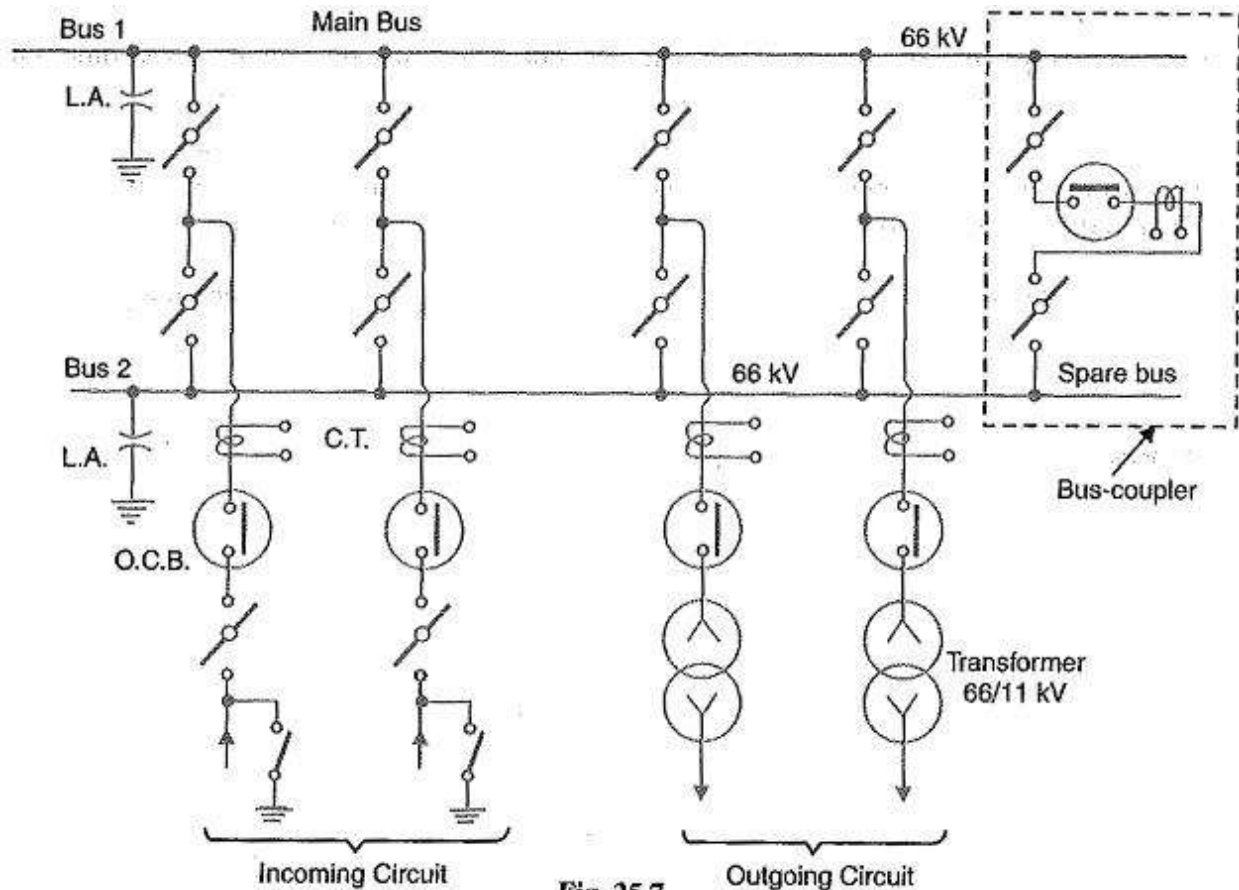

Fig. 25.7

Fig. 25.7 shows the arrangement of duplicate bus-bar system in a typical sub-station. The two 66kV incoming lines can be connected to either bus-bar by a bus-bar coupler. The two 11 kV outgoing lines are connected to the bus-bars through transformers (66/11 kV) and circuit breakers.

### TERMINAL AND THROUGH SUBSTATIONS:

All the transformer sub-stations in the line of power system handle incoming and outgoing lines. Depending upon the manner of incoming lines, the sub-stations are classified as :

- Terminal sub-station
- Through sub-station

### TERMINAL SUB-STATION:

A terminal sub-station is one in which the line supplying to the substation terminates or ends. It may be located at the end of the main line or it may be situated at a point away from main line route. In the latter case, a tapping is taken from the main line to supply to the sub-station. Fig. 25.8 shows the schematic connections of a terminal sub-station. It is clear that incoming 11 kV main line terminates at the sub-station. Most of the distribution sub-stations are of this type.

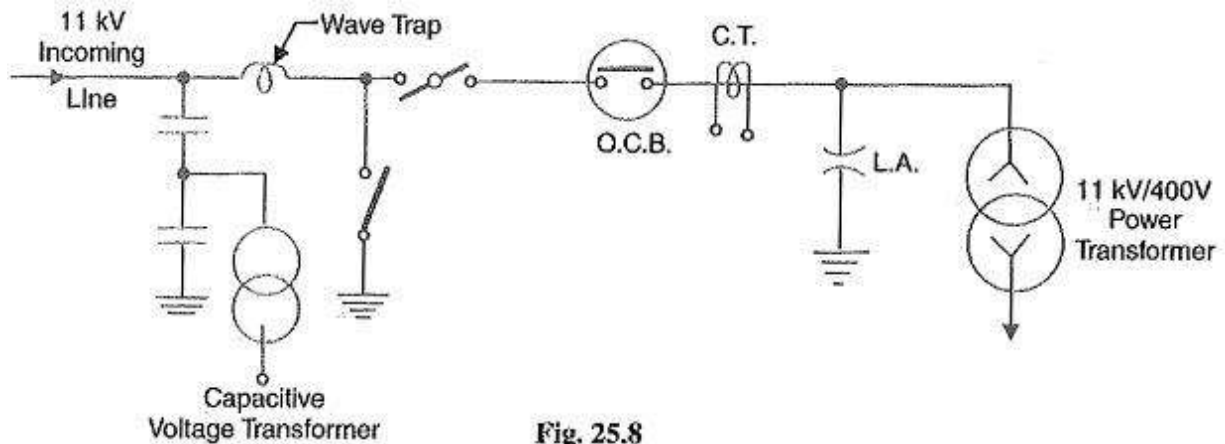

Fig. 25.8

### THROUGH SUB-STATION:

A through sub-station is one in which the incoming line passes 'through' at the same voltage. A tapping is generally taken from the line to feed to the transformer to reduce the voltage to the desired level. Fig. 25.9 shows the schematic connections of a through substation. The incoming 66 kV line passes through the sub-station as 66kV outgoing line. At the same time, the incoming line is tapped in the sub-station to reduce the voltage to 11 kV for secondary distribution.

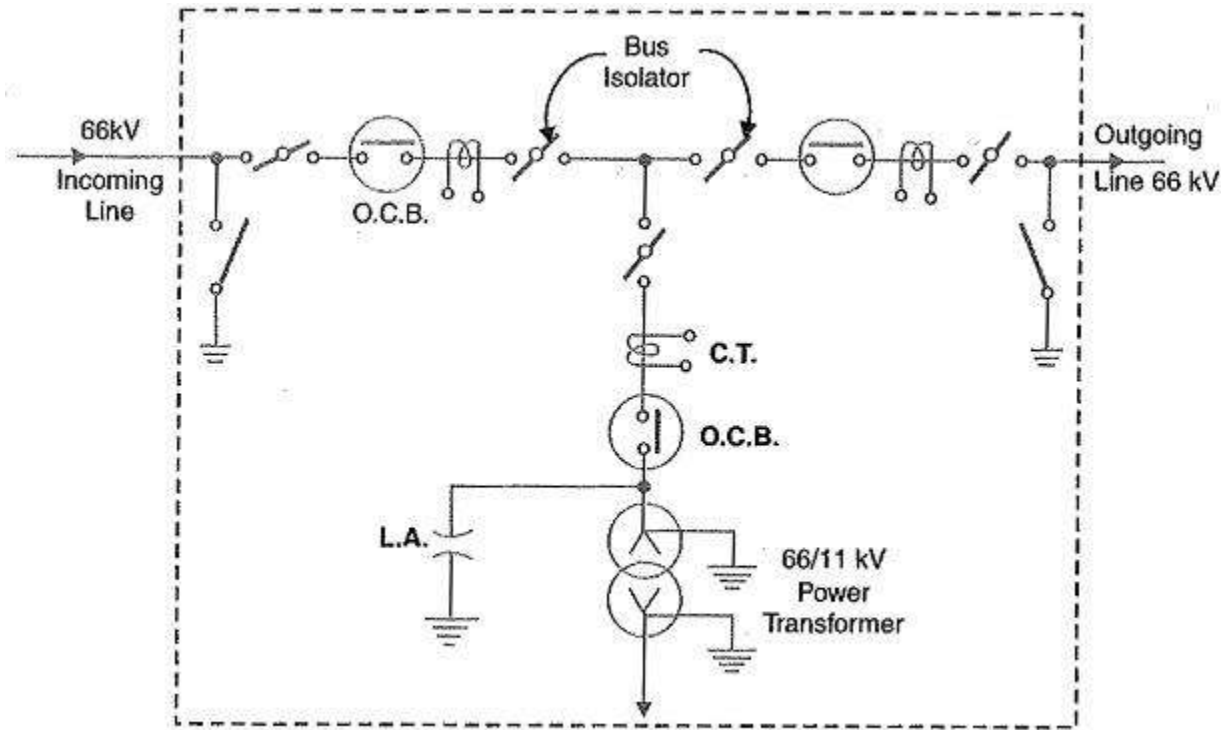

Fig. 25.9

### BUS-BAR ARRANGEMENT: (VERSION 2.0)

Different bus-bar arrangements in an electric circuit will be discussed here. All the diagrams refer to 3-phase arrangement but are shown in single phase for simplicity.

#### **Type # 1. Single Bus-Bar Arrangement:**

This is the simplest arrangement consisting of a single set of bus-bars for the full length of the switchboard and to this set of bus-bars are connected all the generators, transformers and feeders, as illustrated by single line diagram in Fig. 1.10. Each generator and feeder is controlled by a circuit breaker. The isolators permit isolation of generators, feeders and circuit breakers from the bus-bars for maintenance. The chief advantages of such a bus-bar arrangement are low initial cost, less maintenance and simple operation.

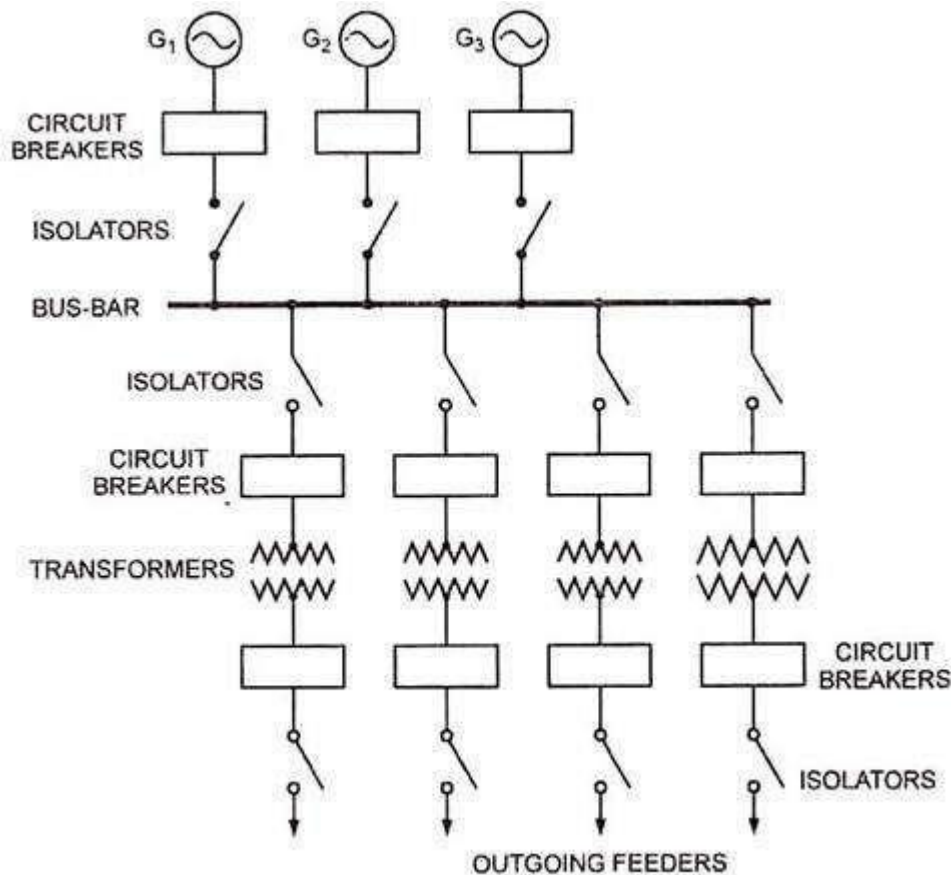

**Fig. 1.10. Single Bus-Bar Arrangement**

The glaring drawback of this system is that in case of fault on the bus-bars, whole of the supply is affected and all the healthy feeders are disconnected. Moreover, when maintenance is to be carried out on any of the feeder sections or on a part of bus-bar the whole supply is to be disrupted. Thus such an arrangement provides least flexibility and immunity from total shutdown.

Such bus-bar arrangement is employed for switchboards, small and medium sized substations, small power stations and dc stations.

### Type # 2. Single Bus-Bar Arrangement with Bus Sectionalization:

The bus-bar may be sectionalized by a circuit breaker and isolating switches so that a fault on one part does not cause a complete shutdown. In large generating stations, where several units are installed, it is a common practice to sectionalize the bus as illustrated in Fig. 1.11.

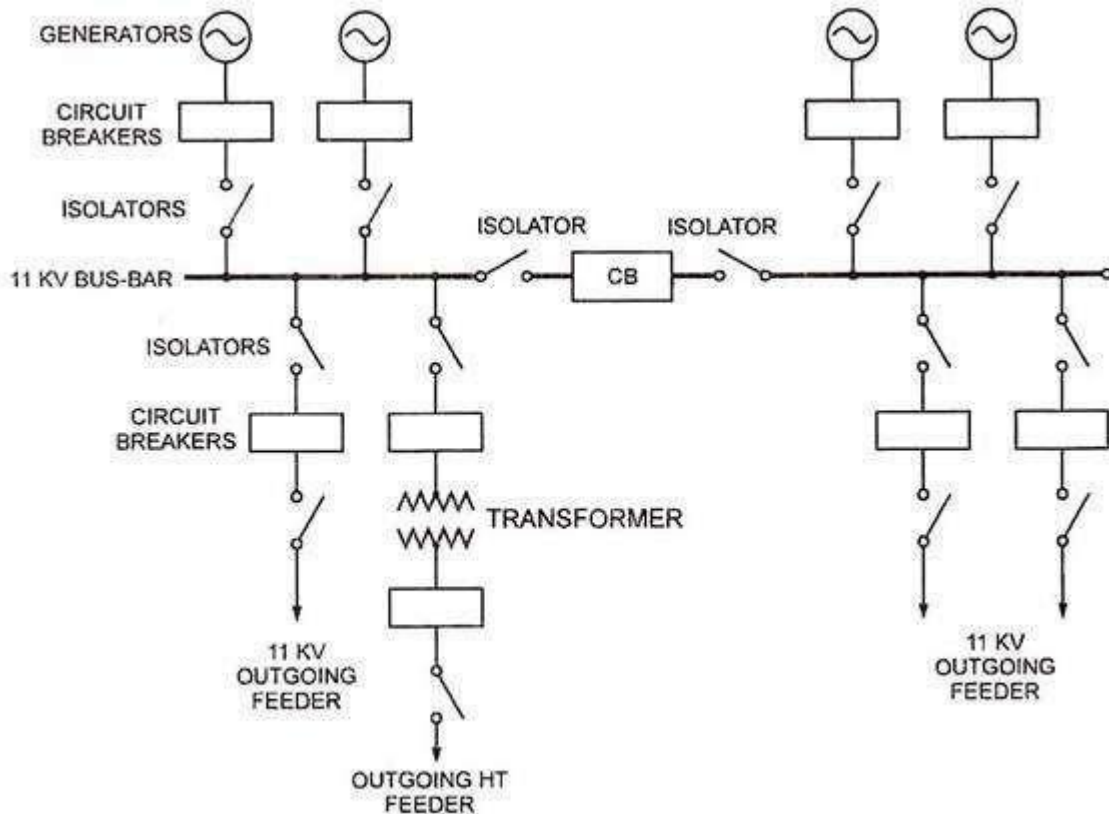

Fig. 1.11. Sectionalized Single Bus-Bar System

Normally the number of sections of a bus-bar are 2 to 3 in a substation, but actually it is limited by the short-circuit current to be handled. In a sectionalized bus-bar arrangement only one additional circuit breaker is required which does not cost much in comparison to the total cost of the bus-bar system.

Such an arrangement provides three main advantages over simple single bus-bar arrangement. Firstly, in the event of occurrence of fault on any section of the bus-bar, the faulty section can be isolated without affecting the supply of other section or sections.

Secondly, one section can be completely shut-down for maintenance and repairs without affecting the supply of the other section (s). Thirdly, by adding a current limiting reactor between the sections the fault level (MVA) can be reduced thereby circuit breakers of lower capacity can be used.

At times air-break isolators were used in place of circuit breakers as bus-sectionalizer due to economy, but it must be remembered that any isolation affected by them must be affected under off-load conditions otherwise it may cause spark. It will be preferable to provide circuit breaker as a sectionalizing switch so that uncoupling of bus-bar may be carried out safely during load transfer.

A double isolation is however necessary when the circuit breaker is employed as sectionalizing switch so that the maintenance work can be carried out on circuit breaker while the bus-bars are alive.

### Type # 3. Main and Transfer Bus Arrangement:

This arrangement has been quite frequently adopted where the loads and continuity of supply justify additional costs. This arrangement provides additional flexibility, continuity of supply and allows periodic maintenance without total shutdown. Such an arrangement is suitable for highly interconnected power network in which flexibility is very important.

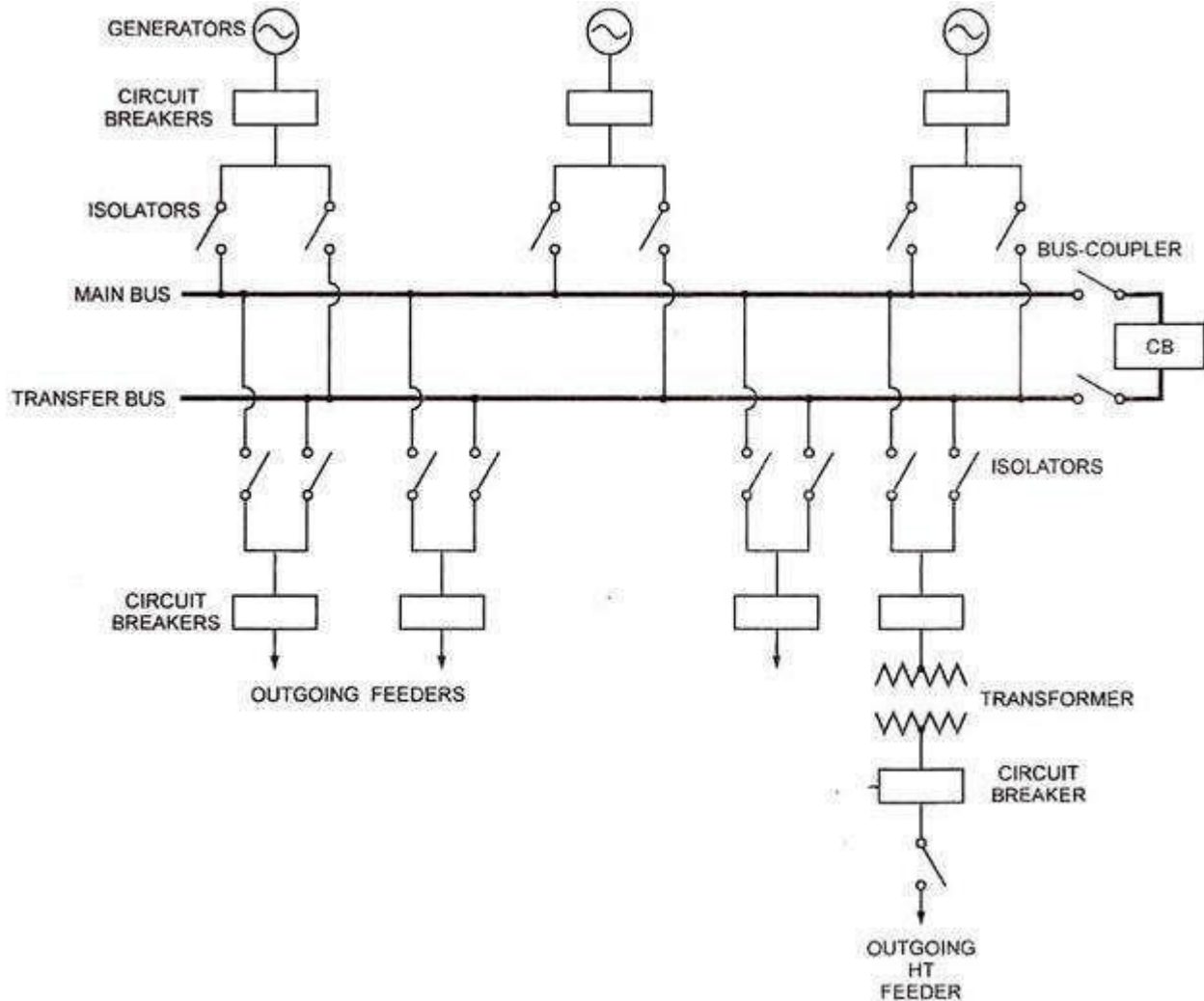

Fig. 1.12. Main and Transfer Bus Arrangement

Figure 1.12 illustrates the main and transfer bus arrangement in a generating station. Such an arrangement consists of two bus-bars, known as main bus-bar and transfer bus-bar used as an auxiliary bus-bar. Each generator and feeder may be connected to either bus-bar with the help of bus coupler which consists of a circuit breaker and isolating switches. In this arrangement a bus coupler is usually used so that change-over from one bus-bar to the other can be carried out under load conditions.

**While transferring the load to the reserve bus, the following steps may be taken:**

1. Close the bus-coupler (circuit breaker) so as to make the two buses at the same potential.
2. Close isolators on the reserve bus.
3. Open isolators on the main bus.

The load is now transferred to the reserve or auxiliary bus and main bus is disconnected.

**The advantages and disadvantages of the arrangement are gives below:**

**Advantages:**

1. It ensures continuity of supply in case of bus fault. In the event of occurrence of fault on one of the bus, the entire load can be transferred to the other bus.
2. Repair and maintenance can be carried out on the main bus without interrupting the supply as the entire load can be transferred to the auxiliary bus.
3. Each load can be supplied from either bus.
4. The infeed and load circuit may be divided into two separate groups if required from operational considerations.
5. The testing and maintenance of feeder circuit breakers can be done by putting them on spare bus, thus keeping the main bus undisturbed.
6. The maintenance cost of substation is lowered.
7. The bus potential can be used for relays.

**Disadvantages:**

1. Additional costs.
2. The bus is maintained or expanded by transferring all of the circuits to the auxiliary bus depending upon the remote backup relays and breakers for removing faults of the circuits. During this condition a line fault on any of the circuits of the bus would shut-down the entire station.

**Type # 4. Double Bus Double Breaker Arrangement:**

In very important power stations two circuit breakers are employed for each circuit, as illustrated in Fig. 1.13. Such a bus-bar arrangement does not require any bus-coupler and permits switchover from one bus to the other whenever desired, without interruption. This bus arrangement is very costly and its maintenance cost is also high.

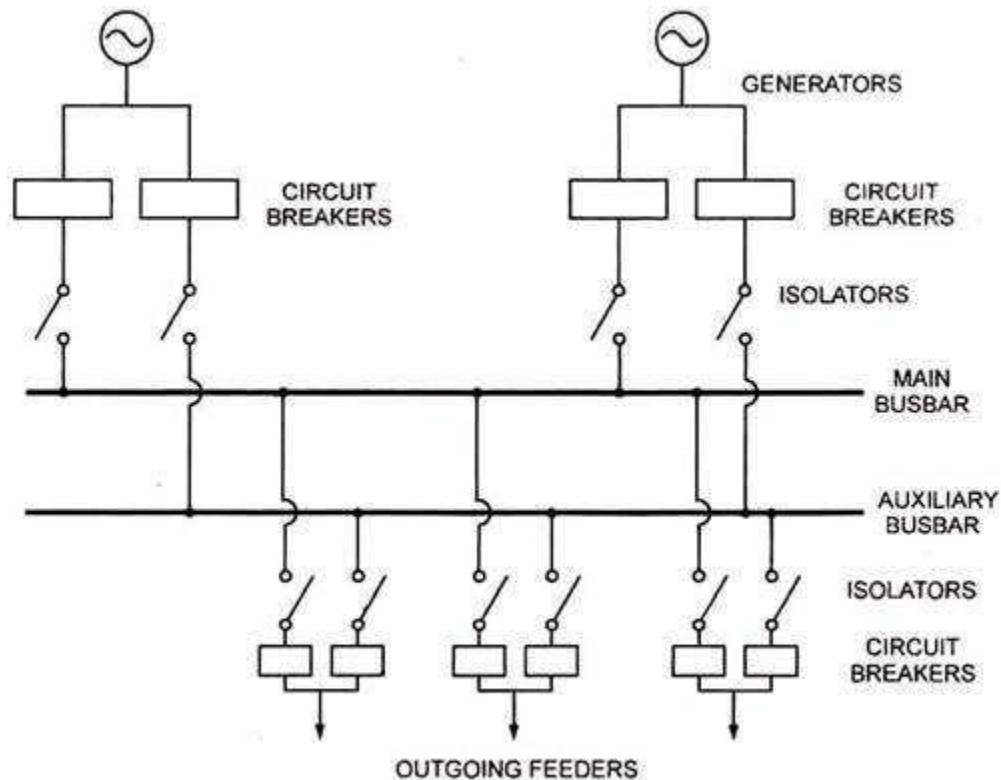

**Fig. 1.13. Double Bus Double Breaker Arrangement**

This arrangement provides maximum flexibility and reliability as the faults and maintenance interrupt the supply to the minimum. A circuit breaker can be opened for repairs and usual checks and the load can be shifted on the other circuit breaker easily. But because of its higher cost, this arrangement is seldom used at the substations.

For 400 kV switchyards two main buses plus one transfer bus scheme is preferred. The transfer bus is used for transferring power from main bus 1 to main bus 2 and vice-versa.

#### **Type # 5. Sectionalized Double Bus Arrangement:**

In this arrangement duplicate bus-bars are used with the main bus-bar in sections connected through a bus-coupler, as illustrated in Fig. 1.14. In this arrangement, any section of bus-bar can be isolated for maintenance, while any section may be synchronised with any other through the auxiliary bus-bar. Sectionalization of auxiliary bus-bar is not required and would increase the cost if done.

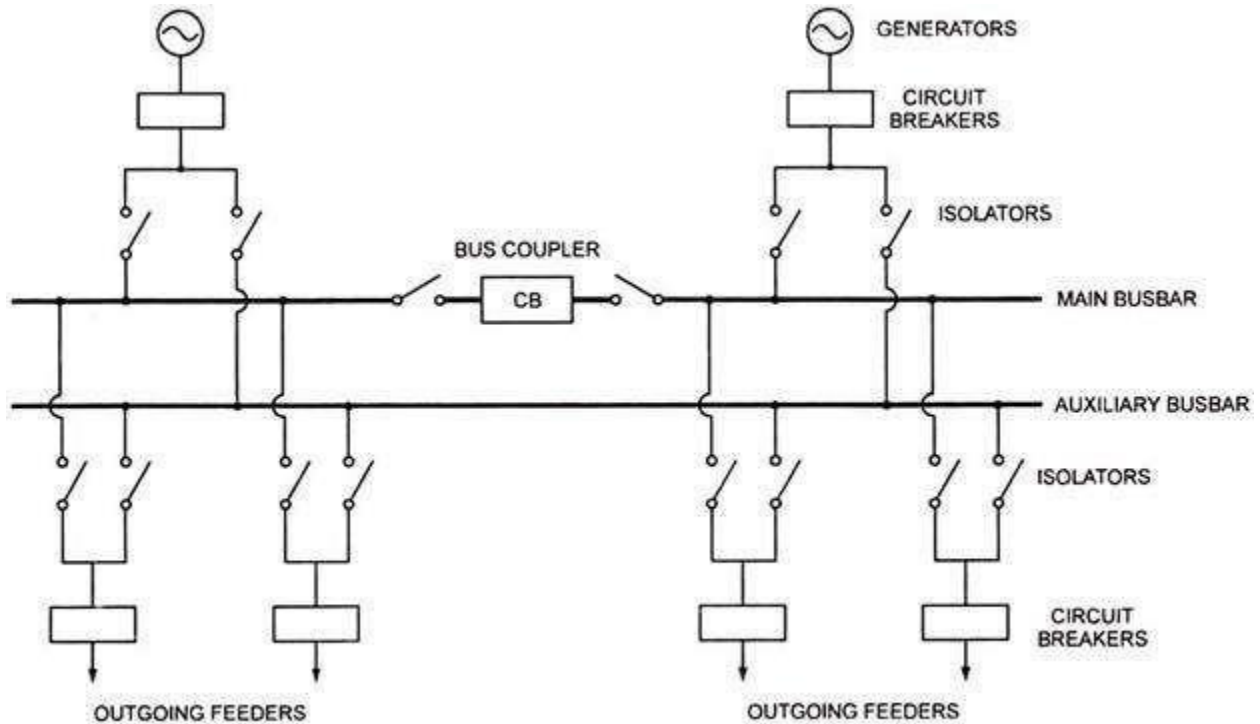

Fig. 1.14. Sectionalized Double Bus Arrangement

#### Type # 6. One-and a Half Breaker Arrangement:

This is an improvement over double bus double breaker arrangement and it affects saving in the number of circuit breakers. This arrangement needs three circuit breakers for two circuits. The number of circuit breakers per circuit comes out to be  $1\frac{1}{2}$  hence the name. This arrangement is preferred in important large stations where power handled per circuit is large. This arrangement is shown in Fig. 1.15. This arrangement provides high security against loss of supply as a fault in a bus or in a breaker will not interrupt the supply. Possibility of addition of circuits to the system is another advantage. The bus potential can be used as supply to relays, however, at the time of bus fault such potential to the relay should be thrown off.

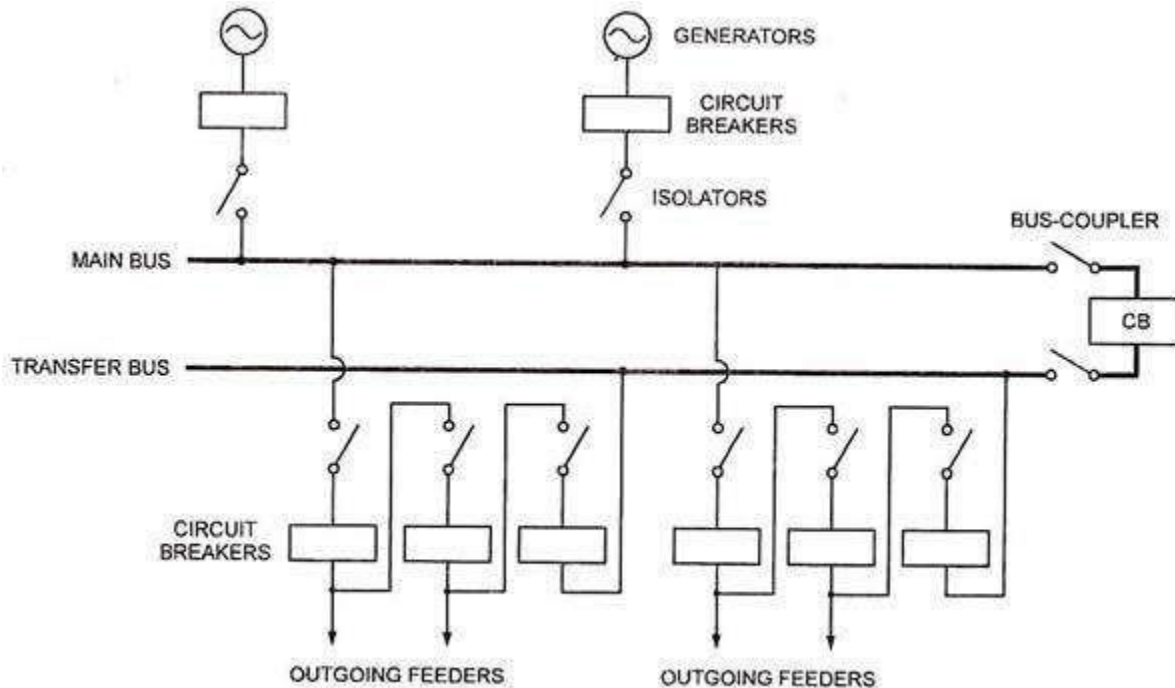

Fig. 1.15. One-and-a-Half Circuit Breaker Arrangement

The main drawback of this arrangement is complications in relaying system because at the time of fault two breakers are to be opened. The other drawback is that for maintenance of circuit breakers if the load shedding is not used, two breakers are to be opened in which case the other circuit in the line-up will be operating with one breaker from one bus only. At the time of fault in that bus supply to the other circuit is also interrupted. The maintenance cost is higher.

The above arrangement has been used in important 400 kV and 750 kV substations.

#### **Type # 7. Ring Main Arrangement:**

This is an extension of the sectionalized bus-bar arrangement where the ends of the bus-bars are returned upon themselves to form a ring, as illustrated in Fig. 1.16. This arrangement provides greater flexibility as each feeder is supplied by two paths, so that the failure of a section does not cause any interruption of the supply.

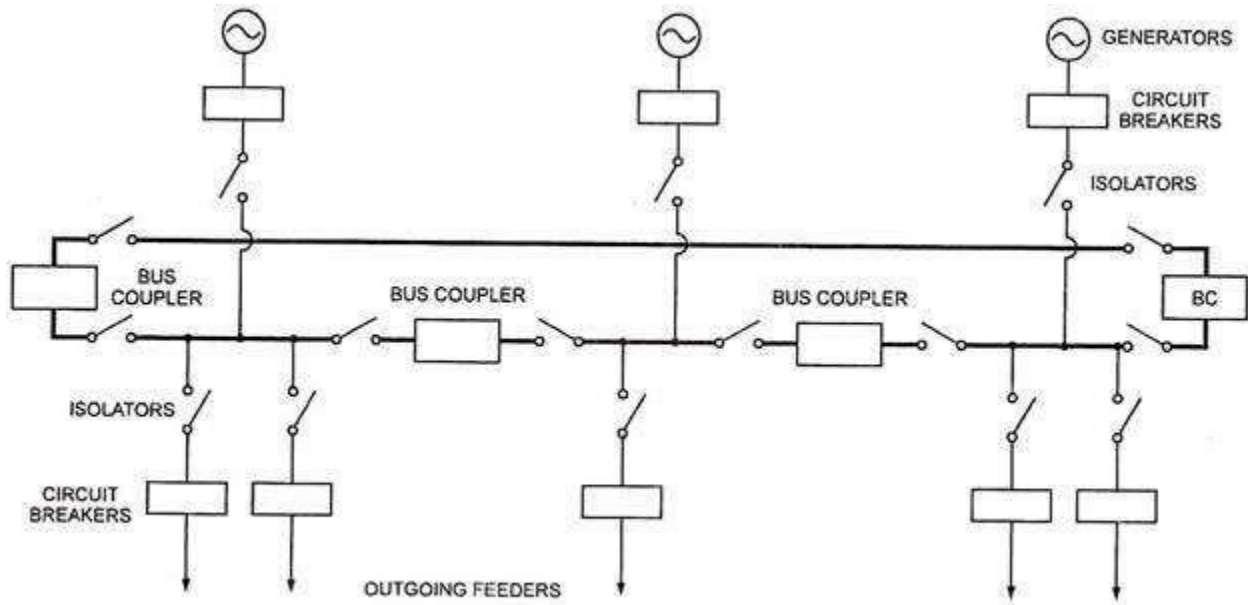

Fig. 1.16. Ring Main Arrangement

The effect of fault in one section is localised to that section alone. The rest of the sections continue to operate. Circuit breakers can be maintained without interrupting the supply. The cost is also not much as the numbers of breakers used are nearly the same as that of a single bus-bar system.

**The drawbacks of the system are:**

- (i) Difficulties in addition of any new circuit in the ring,
- (ii) Possibility of overloading of the circuits on opening of any section of the breaker and
- (iii) Necessity of supplying potential to relays separately to each of the circuit.

**Type # 8. Mesh Arrangement:**

This is another arrangement making economical use of circuit breakers in a substation. In this bus-bar arrangement, the circuit breakers are installed in the mesh formed by the buses, as illustrated in Fig. 1.17. The circuits are tapped from the node points of the mesh. In Fig. 1.17 eight circuits are controlled by four circuit breakers.

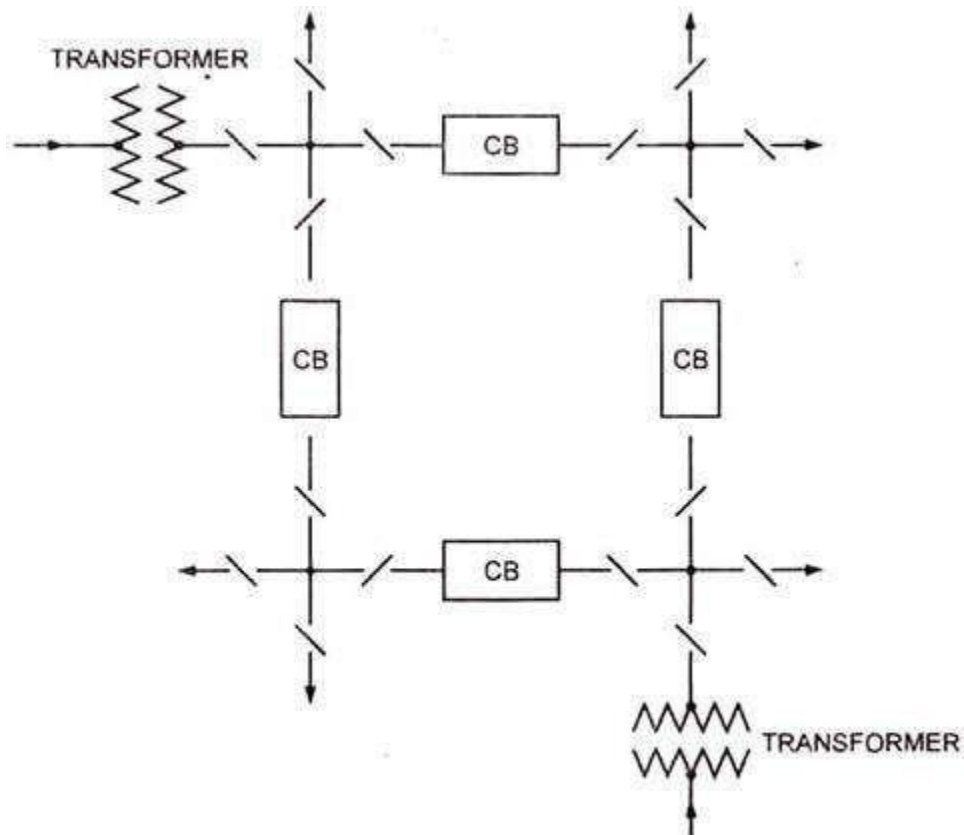

**Fig. 1.17. Mesh Arrangement**

When fault occurs on any section, two circuit breakers have to open, resulting in opening of the mesh. This arrangement provides security against bus-bar faults but lacks switching facility. It needs fewer circuit breakers than that required by one-and a half breaker arrangement. It is preferred for substations having large number of circuits.