

# COURSE MATERIAL

II Year B.Tech II - Semester  
MECHANICAL ENGINEERING  
AY: 2025-26



---

**DYNAMICS OF MACHINERY**

**R24A0310**

---



Prepared by:  
**Mr.C.Daksheeswara Reddy**  
Assistant Professor



**MALLA REDDY COLLEGE OF ENGINEERING & TECHNOLOGY**

**DEPARTMENT OF MECHANICAL ENGINEERING**

(Autonomous Institution-UGC, Govt.of India)  
Secunderabad-500100,Telangana State, India.

[www.mrcet.ac.in](http://www.mrcet.ac.in)



# MALLA REDDY COLLEGE OF ENGINEERING & TECHNOLOGY

(Autonomous Institution – UGC, Govt. of India)  
DEPARTMENT OF MECHANICAL ENGINEERING

---

## CONTENTS

1. Vision, Mission & Quality Policy
2. Pos, PSOs & PEOs
3. Blooms Taxonomy
4. Course Syllabus
5. Lecture Notes (Unit wise)
  - a. Objectives and outcomes
  - b. Notes
  - c. Presentation Material (PPT Slides/ Videos)
  - d. Industry applications relevant to the concepts covered
  - e. Question Bank for Assignments
  - f. Tutorial Questions
6. Previous Question Papers



# MALLA REDDY COLLEGE OF ENGINEERING & TECHNOLOGY

(Autonomous Institution – UGC, Govt. of India)

---

## VISION

- ❖ To establish a pedestal for the integral innovation, team spirit, originality and competence in the students, expose them to face the global challenges and become technology leaders of Indian vision of modern society.

## MISSION

- ❖ To become a model institution in the fields of Engineering, Technology and Management.
- ❖ To impart holistic education to the students to render them as industry ready engineers.
- ❖ To ensure synchronization of MRCET ideologies with challenging demands of International Pioneering Organizations.

## QUALITY POLICY

- ❖ To implement best practices in Teaching and Learning process for both UG and PG courses meticulously.
- ❖ To provide state of art infrastructure and expertise to impart quality education.
- ❖ To groom the students to become intellectually creative and professionally competitive.
- ❖ To channelize the activities and tune them in heights of commitment and sincerity, the requisites to claim the never - ending ladder of **SUCCESS** year after year.

For more information: [www.mrcet.ac.in](http://www.mrcet.ac.in)

# MALLA REDDY COLLEGE OF ENGINEERING & TECHNOLOGY

(Autonomous Institution – UGC, Govt. of India)

[www.mrcet.ac.in](http://www.mrcet.ac.in)

**Department of Mechanical Engineering**

---

## **VISION**

To become an innovative knowledge center in mechanical engineering through state-of-the-art teaching-learning and research practices, promoting creative thinking professionals.

## **MISSION**

The Department of Mechanical Engineering is dedicated for transforming the students into highly competent Mechanical engineers to meet the needs of the industry, in a changing and challenging technical environment, by strongly focusing in the fundamentals of engineering sciences for achieving excellent results in their professional pursuits.

## **Quality Policy**

- ✓ To pursuit global Standards of excellence in all our endeavors namely teaching, research and continuing education and to remain accountable in our core and support functions, through processes of self-evaluation and continuous improvement.
- ✓ To create a midst of excellence for imparting state of art education, industry-oriented training research in the field of technical education.

# MALLA REDDY COLLEGE OF ENGINEERING & TECHNOLOGY

(Autonomous Institution – UGC, Govt. of India)

www.mrcet.ac.in

Department of Mechanical Engineering

---

## PROGRAM OUTCOMES

Engineering Graduates will be able to:

- 1. Engineering knowledge:** Apply the knowledge of mathematics, science, engineering fundamentals, and an engineering specialization to the solution of complex engineering problems.
- 2. Problem analysis:** Identify, formulate, review research literature, and analyze complex engineering problems reaching substantiated conclusions using first principles of mathematics, natural sciences, and engineering sciences.
- 3. Design/development of solutions:** Design solutions for complex engineering problems and design system components or processes that meet the specified needs with appropriate consideration for the public health and safety, and the cultural, societal, and environmental considerations.
- 4. Conduct investigations of complex problems:** Use research-based knowledge and research methods including design of experiments, analysis and interpretation of data, and synthesis of the information to provide valid conclusions.
- 5. Modern tool usage:** Create, select, and apply appropriate techniques, resources, and modern engineering and IT tools including prediction and modeling to complex engineering activities with an understanding of the limitations.
- 6. The engineer and society:** Apply reasoning informed by the contextual knowledge to assess societal, health, safety, legal and cultural issues and the consequent responsibilities relevant to the professional engineering practice.
- 7. Environment and sustainability:** Understand the impact of the professional engineering solutions in societal and environmental contexts, and demonstrate the knowledge of, and need for sustainable development.
- 8. Ethics:** Apply ethical principles and commit to professional ethics and responsibilities and norms of the engineering practice.
- 9. Individual and teamwork:** Function effectively as an individual, and as a member or leader in diverse teams, and in multidisciplinary settings.
- 10. Communication:** Communicate effectively on complex engineering activities with the engineering community and with society at large, such as, being able to comprehend and write effective reports and design documentation, make effective presentations, and give and receive clear instructions.
- 11. Project management and finance:** Demonstrate knowledge and understanding of the engineering and management principles and apply these to one's own work, as a member and leader in a team, to manage projects and in multidisciplinary environments.

# MALLA REDDY COLLEGE OF ENGINEERING & TECHNOLOGY

(Autonomous Institution – UGC, Govt. of India)

www.mrcet.ac.in

## Department of Mechanical Engineering

---

**12.Life-long learning:** Recognize the need for and have the preparation and ability to engage in independent and life-long learning in the broadest context of technological change.

### PROGRAM SPECIFIC OUTCOMES (PSOs)

- PSO1** Ability to analyze, design and develop Mechanical systems to solve the Engineering problems by integrating thermal, design and manufacturing Domains.
- PSO2** Ability to succeed in competitive examinations or to pursue higher studies or research.
- PSO3** Ability to apply the learned Mechanical Engineering knowledge for the Development of society and self.

### Program Educational Objectives (PEOs)

The Program Educational Objectives of the program offered by the department are broadly listed below:

#### PEO1: PREPARATION

To provide sound foundation in mathematical, scientific and engineering fundamentals necessary to analyze, formulate and solve engineering problems.

#### PEO2: CORE COMPETANCE

To provide thorough knowledge in Mechanical Engineering subjects including theoretical knowledge and practical training for preparing physical models pertaining to Thermodynamics, Hydraulics, Heat and Mass Transfer, Dynamics of Machinery, Jet Propulsion, Automobile Engineering, Element Analysis, Production Technology, Mechatronics etc.

#### PEO3: INVENTION, INNOVATION AND CREATIVITY

To make the students to design, experiment, analyze, interpret in the core field with the help of other inter disciplinary concepts wherever applicable.

#### PEO4: CAREER DEVELOPMENT

To inculcate the habit of lifelong learning for career development through successful completion of advanced degrees, professional development courses, industrial training etc.

# **MALLA REDDY COLLEGE OF ENGINEERING & TECHNOLOGY**

(Autonomous Institution – UGC, Govt. of India)

[www.mrcet.ac.in](http://www.mrcet.ac.in)

**Department of Mechanical Engineering**

---

## **PEO5: PROFESSIONALISM**

To impart technical knowledge, ethical values for professional development of the student to solve complex problems and to work in multi-disciplinary ambience, whose solutions lead to significant societal benefits.

# MALLA REDDY COLLEGE OF ENGINEERING & TECHNOLOGY

(Autonomous Institution – UGC, Govt. of India)

[www.mrcet.ac.in](http://www.mrcet.ac.in)

Department of Mechanical Engineering

---

## Blooms Taxonomy

Bloom's Taxonomy is a classification of the different objectives and skills that educators set for their students (learning objectives). The terminology has been updated to include the following six levels of learning. These 6 levels can be used to structure the learning objectives, lessons, and assessments of a course.

1. **Remembering:** Retrieving, recognizing, and recalling relevant knowledge from long-term memory.
2. **Understanding:** Constructing meaning from oral, written, and graphic messages through interpreting, exemplifying, classifying, summarizing, inferring, comparing, and explaining.
3. **Applying:** Carrying out or using a procedure for executing or implementing.
4. **Analyzing:** Breaking material into constituent parts, determining how the parts relate to one another and to an overall structure or purpose through differentiating, organizing, and attributing.
5. **Evaluating:** Making judgments based on criteria and standard through checking and critiquing.
6. **Creating:** Putting elements together to form a coherent or functional whole; reorganizing elements into a new pattern or structure through generating, planning, or producing.

# MALLA REDDY COLLEGE OF ENGINEERING & TECHNOLOGY

(Autonomous Institution – UGC, Govt. of India)

[www.mrcet.ac.in](http://www.mrcet.ac.in)

Department of Mechanical Engineering

---

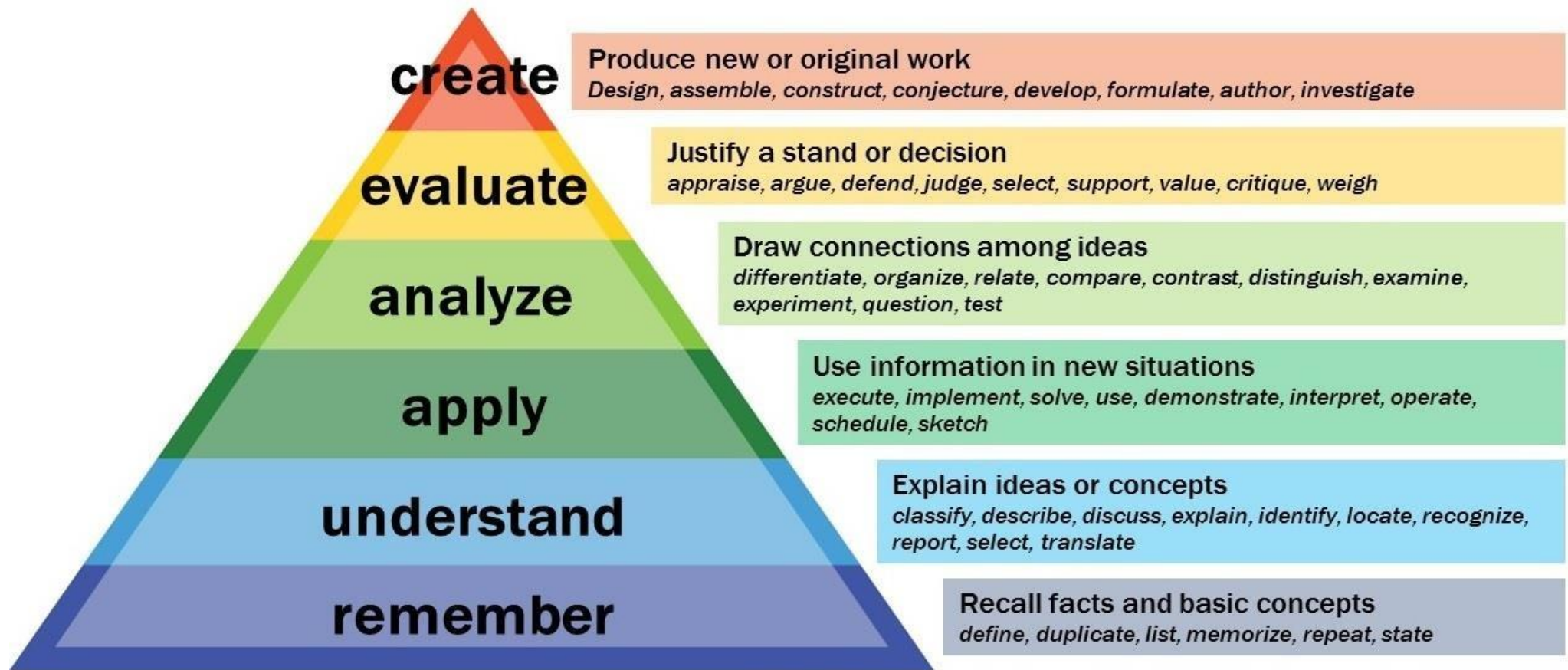

## MALLA REDDY COLLEGE OF ENGINEERING &amp; TECHNOLOGY

II Year B. TECH - II- SEM

L/T/P/C

3/-/-/3

(R24A0310) Dynamics of Machinery

**Course objectives:**

1. To analyze the forces in clutches, brakes and dynamometers involving friction.
2. To Understand the effect gyroscopic couple in motor cycles, aero planes and ships.
3. To understand the static and dynamic force analysis of four bar and slider crank mechanisms.
4. To study the turning moment diagrams of reciprocating engines and to learn design procedure of a flywheel
5. To learn analytical and graphical methods for calculating balancing of rotary and reciprocating masses
6. Understanding of vibrations and its significance on engineering design

**UNIT-I**

**Precession:** Gyroscopes, effect of precession motion on the stability of moving vehicles such as motor car, motor cycle, aero planes and ships.

**UNIT-II**

**Static and Dynamic Force Analysis of Planar Mechanisms:** Introduction -Free Body Diagrams – Conditions for equilibrium – Two, Three and Four Members – Inertia forces and D’Alemberts Principle – planar rotation about a fixed centre.

**Friction and Friction Drives:** Introduction to friction, Laws of friction, Coefficient of friction, Inclined plane, Pivot and Collars, Friction clutches-centrifugal clutch.

**UNIT-III**

**Brakes and Dynamometers:** Simple block brakes, internal expanding brake, band brake of vehicle. Dynamometers – absorption and transmission types.

**Turning moment Diagrams:** Single cylinder double acting steam engine, Four Stroke Cycle Internal Combustion Engine, Multi-cylinder Engine, and Flywheel.

**UNIT-IV**

**Balancing:** Balancing of rotating masses Single and multiple – single and different planes. Balancing of Reciprocating Masses- Primary, Secondary balancing of reciprocating masses using Analytical methods.

**Governors:** Introduction, its types, pendulum, and Gravity Governors

**UNIT-V**

**Vibration:** Free Vibration of mass attached to vertical spring – Simple problems on forced damped vibration, Vibration Isolation & Transmissibility Whirling of shafts, critical speeds, torsional vibrations, two and three rotor systems.

**TEXT BOOKS:**

1. Rattan S.S, “Theory of Machines” Tata McGraw-Hill Publishing Company Ltd., New Delhi, and 2nd edition -2005.
2. Sadhu Singh, “Theory of Machines,” Pearson Education (Singapore) Pvt. Ltd., Indian Branch, New Delhi, 2NDEdi. 2006.
3. Theory of machines, (4th Edition), by R.S. Khurmi, S. Chand Publications.

**REFERENCE BOOKS:**

1. Shigley. J. V. and Uickers, J.J., "Theory of Machines & Mechanisms" OXFORD University press.2004
2. "Theory of Machines -I", by A.S. Ravindra, Sudha Publications, Revised 5th Edi. 2004

**Course outcomes:**

1. To compute the frictional losses and transmission in clutches, brakes and dynamometers
2. To determine the effect of gyroscopic couple in motor vehicles, ships and aero planes
3. To analyze the forces in four bar and slider crank mechanisms and design a flywheel
4. To determine the rotary unbalanced mass in reciprocating equipment
5. To determine the unbalanced forces and couples in reciprocating and radial engines
6. To determine the natural frequencies of discrete systems undergoing longitudinal, torsional and transverse vibrations.



# MALLA REDDY COLLEGE OF ENGINEERING & TECHNOLOGY

(Autonomous Institution – UGC, Govt. of India)

## DYNAMICS OF MACHINERY (R22A0310)

### COURSE OBJECTIVES

UNIT - 1	<b>CO1:</b> To study about gyroscope and its effects during precession motion of moving vehicles.
UNIT - 2	<b>CO2:</b> To understand the force-motion relationship in components subjected to external forces and analysis of standard mechanisms
UNIT - 3	<b>CO3:</b> Able to learn about the working of Clutches, Brakes, Dynamometers and Fly wheel.
UNIT - 4	<b>CO4:</b> To study about the balancing, unbalancing of rotating masses and the effect of Dynamics of undesirable vibrations.
UNIT - 5	<b>CO5:</b> To understand the working principles of different type governors and its characteristics

# Bloom's Taxonomy - Cognitive

## 1 Remember

**Behavior:** To recall, recognize, or identify concepts

## 2 Understand

**Behavior:** To comprehend meaning, explain data in own words

## 3 Apply

**Behavior:** Use or apply knowledge, in practice or real life situations



## 4 Analyze

**Behavior:** Interpret elements, structure relationships between individual components

## 5 Evaluate

**Behavior:** Assess effectiveness of whole concepts in relation to other variables

## 6 Create

**Behavior:** Display creative thinking, develop new concepts or approaches

# COURSE OUTLINE

## UNIT – 1

NO OF LECTURE HOURS: 10

LECTURE	LECTURE TOPIC	KEY ELEMENTS	LEARNING OBJECTIVES (2 to 3 objectives)
1.	Introduction-Gyroscopic	Definition, Precessional Angular Motion	Understand the concept of Gyroscopic (B2).
2.	Gyroscopic Couple	Gyroscopic Couple Derivation,	Understand the concept of Gyroscopic Couple(B2) Understand the how to calculate the moments(B2) Apply the formulas for couple (B3)
3.	Gyroscopic Couple	Effect of the Gyroscopic Couple on an aero plane.	Understand the concept of Gyroscopic Couple on aero plane(B2) Apply the formulas for couple (B3) Evaluate the concept (B5)
4.	Gyroscopic Couple	Effect of Gyroscopic Couple on a Naval Ship during Steering	Understand the concept of Gyroscopic Couple on aero plane(B2) Apply the formulas for couple (B3) Evaluate the concept (B5)
5.	Gyroscopic Couple	Effect of Gyroscopic Couple on a Naval Ship during Rolling	Understand the concept of Gyroscopic Couple on aero plane(B2) Apply the formulas for couple (B3)

			Evaluate the concept (B5)
<b>6.</b>	Gyroscopic Couple	Stability of a Four Wheel Drive Moving in a Curved Path	Understand the concept of Gyroscopic Couple on aero plane(B2) Apply the formulas for couple (B3) Evaluate the concept (B5)
<b>7.</b>	Problems	Problems on Gyroscopic Couple on an aero plane	Understand the concept of Gyroscopic Couple on aero plane(B2) Apply the formulas for couple (B3) Evaluate the concept (B5)
<b>8.</b>	Problems	Problems on Gyroscopic Naval Ship during Steering	Apply the formulas for couple (B3)
<b>9.</b>	Problems	Problems on Gyroscopic Naval Ship during rolling	Apply the formulas for couple (B3)
<b>10.</b>	Practice	Practice on problems	Apply the formulas for couple (B3)

## UNIT – 2

NO OF LECTURE HOURS: 10

LECTURE	LECTURE TOPIC	KEY ELEMENTS	LEARNING OBJECTIVES <b>(2 to 3 objectives)</b>
1.	Static and Dynamic force analysis	Definitions , Inertia force, Resultant Effect of a System of Forces Acting on a Rigid Body	Understand the concept static and Dynamic forces (B2)
2.	Free Body Diagrams & Inertia forces	Two, Three and Four Members, D'Alembert's Principle	Understand the concept of inertia forces(B3)
3.	Friction in Machine Elements	Torque Required to Lifting and lowering the Load by a Screw Jack,	Understand the concept of Gyroscopic Couple on aero plane(B2) Apply the formulas for couple (B3)
4.	Friction in Journal Bearing-Friction Circle	Flat Pivot Bearing , Conical Pivot Bearing,	Understand the concept of Friction in Journal Bearing-Friction Circle (B2)
5.	Friction in Journal Bearing-Friction Circle	Pivot and collars uniform pressure, uniform wear	Understand the concept of Friction in Journal Bearing-Friction Circle (B2)
6.	problems	problems	Apply the formulas (B3)
7.	problems	problems	Apply the formulas (B3)
8.	problems	problems	Apply the formulas (B3)



# MALLA REDDY COLLEGE OF ENGINEERING & TECHNOLOGY

(Autonomous Institution – UGC, Govt. of India)  
DEPARTMENT OF MECHANICAL ENGINEERING

## UNIT – 3

NO OF LECTURE HOURS: 17

LECTURE	LECTURE TOPIC	KEY ELEMENTS	LEARNING OBJECTIVES (2 to 3 objectives)
1.	Introduction of Clutches	Definition, Single Disc or plate clutch	Remember the standard design formulas(B1) Understand the concept (B2) Apply the formulas(B3)
2.	Problems	Problems on Single Disc or plate clutch.	Remember the standard design formulas(B1) Apply the formulas(B3)
3.	CONE CLUTCH	Definition, Derivation	Remember the standard design formulas(B1) Understand the concept (B2) Apply the formulas(B3)
4.	Problems	Problems on CONE CLUTCH	Remember the standard design formulas(B1) Apply the formulas(B3)
5.	centrifugal Clutch	Definition, Derivation.	Remember the standard design formulas(B1) Understand the concept (B2) Apply the formulas(B3)
6.	Problems	Problems on centrifugal Clutch	Remember the standard design formulas(B1) Apply the formulas(B3)
7.	Brakes and Dynamometers	Introduction and Types	Understand the concept (B2) Remember the standard design formulas(B1)
8.	Problems	brakes	Remember the standard design formulas(B1) Apply the formulas(B3)

<b>9.</b>	Brakes	Double Block or Shoe Brake	Understand the concept (B2) Remember the standard design formulas(B1)
<b>10.</b>	Brakes	Internal Expanding Brake	Understand the concept (B2) Remember the standard design formulas(B1)
<b>11.</b>	Problems	Double Block or Shoe Brake	Remember the standard design formulas(B1) Apply the formulas(B3)
<b>12.</b>	Problems	Internal Expanding Brake	Remember the standard design formulas(B1) Apply the formulas(B3)
<b>13.</b>	Dynamometers – absorption and transmission types	Rope Brake Dynamometer, Classification of Transmission Dynamometers	Understand the concept (B2)
<b>14.</b>	Turning Moment and Flywheel	Turning moment diagram for a single cylinder, double acting steam engine, multi cylinder	Understand the concept (B2)
<b>15.</b>	Problems	Turning moment diagram	Remember the standard design formulas(B1) Apply the formulas(B3) Analyze the Data(B4)
<b>16.</b>	Design of flywheel	Dimensions of the Flywheel Rim	Understand the concept (B2)
<b>17.</b>	Problems	Dimensions of the Flywheel Rim	Remember the standard design formulas(B1) Apply the formulas(B3)



# MALLA REDDY COLLEGE OF ENGINEERING & TECHNOLOGY

(Autonomous Institution – UGC, Govt. of India)  
DEPARTMENT OF MECHANICAL ENGINEERING

## UNIT – 4

NO OF LECTURE HOURS:13

LECTURE	LECTURE TOPIC	KEY ELEMENTS	LEARNING OBJECTIVES (2 to 3 objectives)
1.	Balancing	Introduction, Balancing of a single rotating mass by a single mass rotating in the same plane	Remember the standard design formulas(B1) Understand the concept (B2)
2.	Balancing	Balancing of a single rotating mass by two masses rotating in different planes.	Remember the standard design formulas(B1) Understand the concept (B2)
3.	Balancing	Balancing of different masses rotating in the same plane. Balancing of different masses rotating in different planes.	Remember the standard design formulas(B1) Understand the concept (B2)
4.	Balancing of Coupled Locomotives	Balancing of Primary Forces of Multi-cylinder In-line Engines	Remember the standard design formulas(B1) Apply the formulas(B3)

<b>5.</b>	Balancing of Coupled Locomotives	Balancing of Secondary Forces of Multi-cylinder In-line Engines	Remember the standard design formulas(B1) Apply the formulas(B3)
<b>6.</b>	Problems	Problems	Remember the standard design formulas(B1) Apply the formulas(B3)
<b>7.</b>	Problems	Problems	Remember the standard design formulas(B1) Apply the formulas(B3)
<b>8.</b>	Problems	Problems	Remember the standard design formulas(B1) Apply the formulas(B3)
<b>9.</b>	Vibrations	Terms Used in Vibratory Motion, Types of Free Vibrations, Derivations.	Remember the standard design formulas(B1) Understand the concept (B2)
<b>10.</b>	Free Torsional Vibrations of a Two Rotor System	Concept and Derivation	Understand the concept (B2) Remember the standard formulas(B1)
<b>11.</b>	Free Torsional Vibrations of a Three Rotor System	Concept and Derivation	Understand the concept (B2) Remember the standard formulas(B1)
<b>12.</b>	Problems	Free torsional vibrations of a two rotor system	Remember the standard design formulas(B1) Apply the formulas(B3)
<b>13.</b>	Problems	Free Torsional Vibrations of a Three Rotor System	Remember the standard design formulas(B1) Apply the formulas(B3)

## UNIT – 5

NO OF LECTURE HOURS: 08

LECTUR E	LECTURE TOPIC	KEY ELEMENTS	LEARNING OBJECTIVES <b>(2 to 3 objectives)</b>
1.	Introduction	Governors, Classification, Watt, Porter	Understand the concept (B2)
2.	Method of resolution of forces	Method of resolution of forces, Instantaneous centre method	Understand the concept (B2)
3.	Types of governors	Proell governors	Remember the standard design formulas(B1) Understand the concept (B2)
4.	Types of governors	Spring loaded governors – Hartnell and hartung with auxiliary springs Derivations	Remember the standard design formulas(B1) Understand the concept (B2)
5.	Types of governors	Sensitiveness, isochronism and hunting.	Remember the standard design formulas(B1) Understand the concept (B2)
6.	problems	Problems on all types of governors	Analyze the data(B4) Remember the standard design formulas(B1) Apply the formulas(B3)
7.	problems	Problems on all types of governors	Analyze the data(B4) Remember the standard design formulas(B1) Apply the formulas(B3)

8.	problems	Problems on all types of governors	Analyze the data(B4) Remember the standard design formulas(B1) Apply the formulas(B3)
----	----------	------------------------------------	---



---

# **UNIT 1**

# **PRECESSION**

---



## **COURSE OBJECTIVES**

To study about gyroscope and its effects during precession motion of moving vehicles.

## **COURSE OUTCOMES**

Knowledge acquired about Gyroscope and its precession motion.



## Introduction

When a body moves along a curved path with a uniform linear velocity, a force in the direction of centripetal acceleration (known as centripetal force) has to be applied externally over the body, so that it moves along the required curved path. This external force applied is known as **active force**.

When a body, itself, is moving with uniform linear velocity along a circular path, it is subjected to the centrifugal force\* radially outwards. This centrifugal force is called **reactive force**. The action of the reactive or centrifugal force is to tilt or move the body along radially outward direction.

## Precessional Angular Motion

We have already discussed that the angular acceleration is the rate of change of angular velocity with respect to time. It is a vector quantity and may be represented by drawing a vector diagram with the help

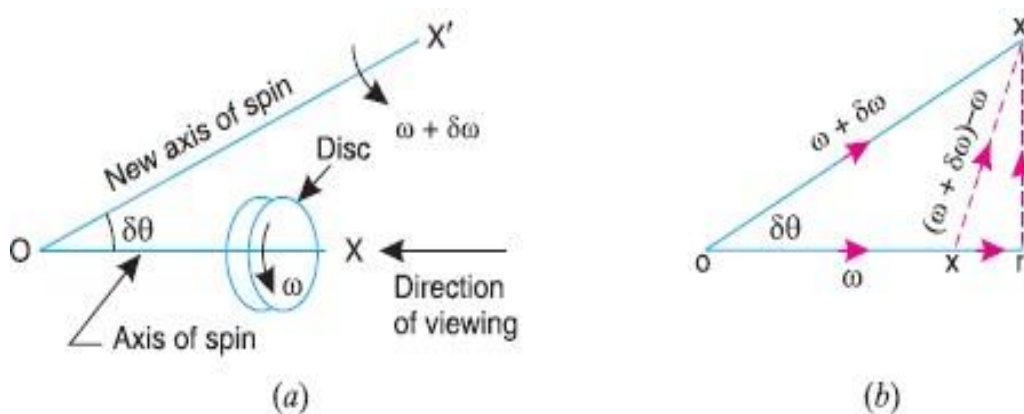

of right hand screw rule.

Consider a disc, as shown in Fig (a), revolving or spinning about the axis  $OX$  (known as **axis of spin**) in anticlockwise when seen from the front, with an angular velocity  $\omega$  in a plane at right angles to the paper.

After a short interval of time  $\delta t$ , let the disc be spinning about the new axis of spin  $OX'$  (at an angle  $\delta\theta$ ) with an angular velocity  $(\omega + \delta\omega)$ . Using the right hand screw rule, initial angular velocity of the disc ( $\omega$ ) is represented by vector  $ox$ ; and the final angular velocity of the disc  $(\omega + \delta\omega)$  is represented by vector  $ox'$  as shown in Fig. 14.1 (b). The vector  $xx'$  represents the change of angular velocity in time  $\delta t$  i.e. the angular

**Component of angular acceleration in the direction of  $ox$ ,**

$$\begin{aligned}\alpha_t &= \frac{xr}{\delta t} = \frac{or - ox}{\delta t} = \frac{ox' \cos \delta\theta - ox}{\delta t} \\ &= \frac{(\omega + \delta\omega) \cos \delta\theta - \omega}{\delta t} = \frac{\omega \cos \delta\theta + \delta\omega \cos \delta\theta - \omega}{\delta t}\end{aligned}$$

Since  $\delta\theta$  is very small, therefore substituting  $\cos \delta\theta = 1$ , we have

$$\alpha_t = \frac{\omega + \delta\omega - \omega}{\delta t} = \frac{\delta\omega}{\delta t}$$

acceleration of the disc. This may be resolved into two components.

One parallel to  $ox$  and the other perpendicular to  $ox$ .



In the limit, when  $\delta t \rightarrow 0$ ,

$$\alpha_t = \lim_{\delta t \rightarrow 0} \left( \frac{\delta \omega}{\delta t} \right) = \frac{d\omega}{dt}$$

Component of angular acceleration in the direction perpendicular to  $ox$ ,

$$\alpha_c = \frac{rx'}{\delta t} = \frac{ox' \sin \delta \theta}{\delta t} = \frac{(\omega + \delta \omega) \sin \delta \theta}{\delta t} = \frac{\omega \sin \delta \theta + \delta \omega \cdot \sin \delta \theta}{\delta t}$$

Since  $\delta \theta$  is very small, therefore substituting  $\sin \delta \theta = \delta \theta$ , we have

$$\alpha_c = \frac{\omega \cdot \delta \theta + \delta \omega \cdot \delta \theta}{\delta t} = \frac{\omega \cdot \delta \theta}{\delta t}$$

...(Neglecting  $\delta \omega \cdot \delta \theta$ , being very small)

In the limit when  $\delta t \rightarrow 0$ ,

$$\alpha_c = \lim_{\delta t \rightarrow 0} \frac{\omega \cdot \delta \theta}{\delta t} = \omega \times \frac{d\theta}{dt} = \omega \cdot \omega_p \quad \dots \left( \text{Substituting } \frac{d\theta}{dt} = \omega_p \right)$$

$\therefore$  Total angular acceleration of the disc

= vector  $xx'$  = vector sum of  $\alpha_t$  and  $\alpha_c$

$$= \frac{d\omega}{dt} + \omega \times \frac{d\theta}{dt} = \frac{d\omega}{dt} + \omega \cdot \omega_p$$

Where  $d\theta/dt$  is the angular velocity of the axis of spin about a certain axis, which is perpendicular to the plane in which the axis of spin is going to rotate. This angular velocity of the axis of spin (i.e.  $d\theta/dt$ ) is known as angular velocity of precession and is denoted by  $\omega_p$ . The axis, about which the axis of spin is to turn, is known as axis of precession. The angular motion of the axis of spin about the axis of precession is known as precessional angular motion.

### Gyroscopic Couple

Consider a disc spinning with an angular velocity  $\omega$  rad/s about the axis of

spin  $OX$ , in anticlockwise direction when seen from the front, as shown in Fig. 14.2 (a). Since the plane in which the disc is rotating is parallel to the plane  $YOZ$ , therefore it is called plane of spinning. The plane  $XOZ$  is a horizontal plane and the axis of spin rotates in a plane parallel to the horizontal plane about an axis  $OY$ . In other words, the axis of spin is said to be rotating or processing about an axis  $OY$ . In other words, the axis of spin is said to be rotating or processing about an axis  $OY$  (which is perpendicular to both the axes  $OX$  and  $OZ$ ) at an angular velocity  $\omega_p$  rap/s. This horizontal plane  $XOZ$  is called plane of precession and  $OY$  is the axis of precession.

Let  $I$  = Mass moment of inertia of the disc about  $OX$ , and  $\omega$  = Angular velocity of the disc.

Angular momentum of the disc =  $I \cdot \omega$

Since the angular momentum is a vector quantity, therefore it may be represented by the vector  $ox'$ , as shown in Fig. 14.2 (b). The axis of spin  $OX$  is also rotating anticlockwise when seen from the top about the axis  $OY$ . Let the axis  $OX$  is turned in the plane  $XOZ$  through a small angle  $\delta \theta$  radians to the position  $OX'$ , in



time  $\delta t$  seconds. Assuming the angular velocity  $\omega$  to be constant, the angular momentum will now be represented by vector  $ox'$ .

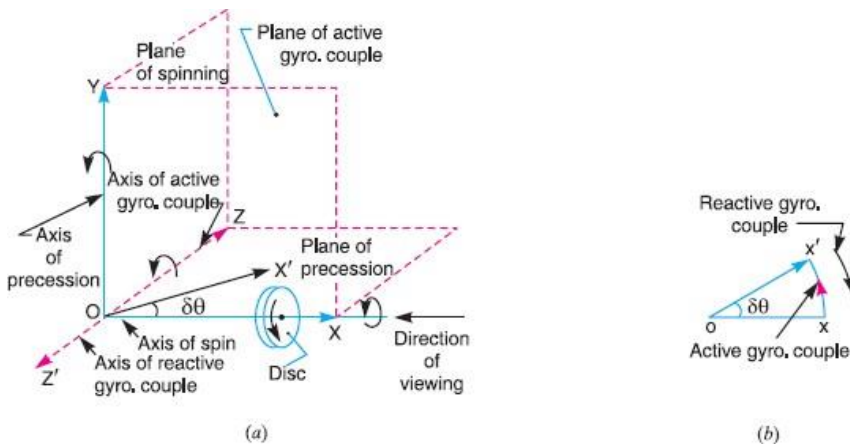

$$= ox' - ox = xx' = ox \cdot \delta\theta \quad \dots(\text{in the direction of } xx')$$

$$= I \cdot \omega \cdot \delta\theta$$

Change in angular momentum and rate of change of angular momentum

$$= I \cdot \omega \times \frac{\delta\theta}{dt}$$

$$C = \lim_{\delta t \rightarrow 0} I \cdot \omega \times \frac{\delta\theta}{\delta t} = I \cdot \omega \times \frac{d\theta}{dt} = I \cdot \omega \cdot \omega_p \quad \dots \left( \because \frac{d\theta}{dt} = \omega_p \right)$$

Since the rate of change of angular momentum will result by the application of a couple to the disc,

Therefore the couple applied to the disc causing precession,

Where  $\omega_p$  = Angular velocity of precession of the axis of spin or the speed of rotation of the axis of spin about the axis of precession OY.

The couple  $I \cdot \omega \cdot \omega_p$ , in the direction of the vector  $xx'$  (representing the change in angular momentum) is the *active gyroscopic couple*, which has to be applied over the disc when the axis of spin is made to rotate with angular velocity  $\omega_p$  about the axis of precession. The vector  $xx'$  lies in the plane XOZ or the horizontal plane. In case of a very small displacement  $\delta\theta$ , the vector  $xx'$  will be perpendicular to the vertical plane XOY. Therefore the couple causing this change in the angular momentum will lie in the plane XOY. The vector  $xx'$ , as shown in Fig(b), represents an anticlockwise couple in the plane XOY. Therefore, the plane XOY is called the *plane of active gyroscopic couple* and the axis OZ perpendicular to the plane XOY, about which the couple acts, is called the axis of active gyroscopic couple.

When the axis of spin itself moves with angular velocity  $\omega_p$ , the disc is subjected to *reactive couple* whose magnitude is same (i.e.  $I \cdot \omega \cdot \omega_p$ ) but opposite in direction to that of active couple. This reactive couple to which the disc is subjected when the axis of spin



rotates about the axis of precession is known as *reactive gyroscopic couple*. The axis of the reactive gyroscopic couple is represented by  $OZ'$  in Fig(a).

The gyroscopic couple is usually applied through the bearings which support the shaft. The bearings will resist equal and opposite couple.

The gyroscopic principle is used in an instrument or toy known as gyroscope. The gyroscopes are installed in ships in order to minimize the rolling and pitching effects of waves. They are also used in aero planes, monorail cars, gyrocompasses etc.

**Effect of the Gyroscopic Couple on an aero plane:**

The top and front view of an aero plane is shown in Fig (a). Let engine or propeller rotates in the clockwise direction when seen from the rear or tail end and the aero plane takes a turn to the left.

Let  $\omega$  = Angular velocity of the engine in rad/sec,

$m$  = Mass of the engine and the propeller in kg,

$k$  = Its radius of gyration in metre

$I$  = Mass moment of inertia of the engine and the propeller in  $\text{kg-m}^2$

$= mk^2$

$v$  = Linear velocity of the aero plane in m/s,

$R$  = Radius of curvature in metres, and

$\omega_p$  = Angular velocity of precession =  $v/R$

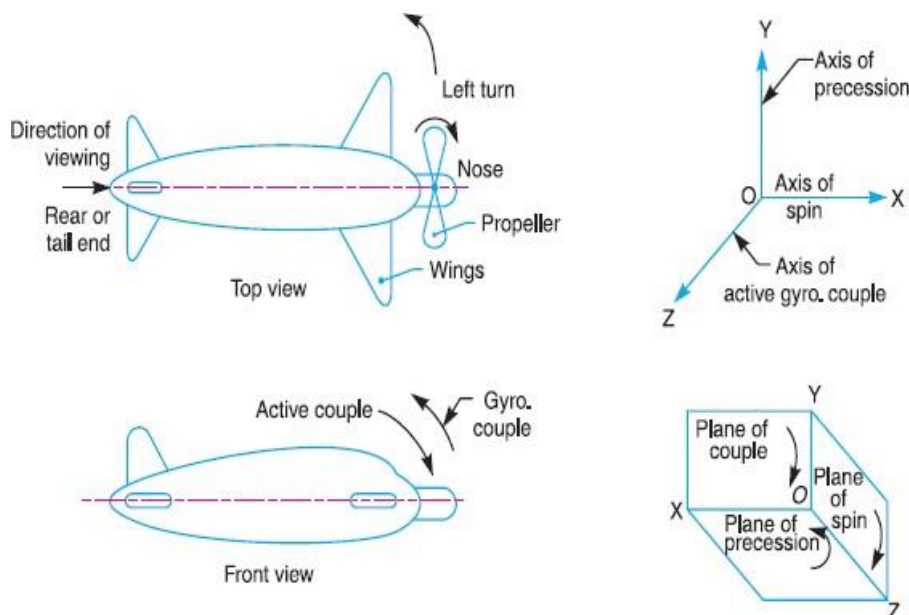

Before taking the left turn, the angular momentum vector is represented by  $ox$ . When it takes left turn, the active gyroscopic couple will change the direction of the angular momentum vector from  $ox$  to  $ox'$  as shown in Fig(a). The vector  $xx'$ , in the limit, represents the change of angular momentum or the active gyroscopic couple and is perpendicular to  $ox$ . Thus the plane of active gyroscopic couple  $XOY$  will be perpendicular to  $xx'$ , i.e. vertical in this case, as shown in Fig (b). By applying right hand screw rule to vector  $xx'$ , we find that the direction of active gyroscopic couple is clockwise as shown in the front view of Fig (a).

In other words, for left hand turning, the active gyroscopic couple on the aero plane in the axis  $OZ$  will be clockwise as shown in Fig (b). The reactive gyroscopic couple (equal in magnitude of active gyroscopic

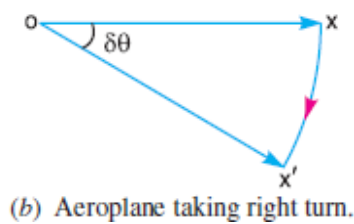
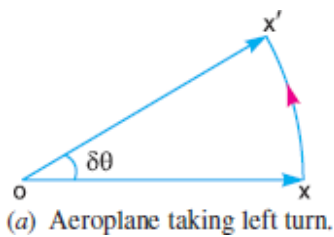

couple) will act in the opposite direction (i.e. in the anticlockwise direction) and the effect of this couple is, therefore, to raise the nose and dip the tail of the aero plane.

Terms Used in a Naval Ship.

The top and front views of a naval ship are shown in Fig 14.7. The fore end of the ship is called **bow** and the rear end is known as **stern** or **aft**. The left hand and right hand sides of the ship, when viewed from the stern are called **port** and **star-board** respectively. We shall now discuss the effect of gyroscopic couple on the naval ship in the following three cases:

Steering,

Pitching,

Rolling.

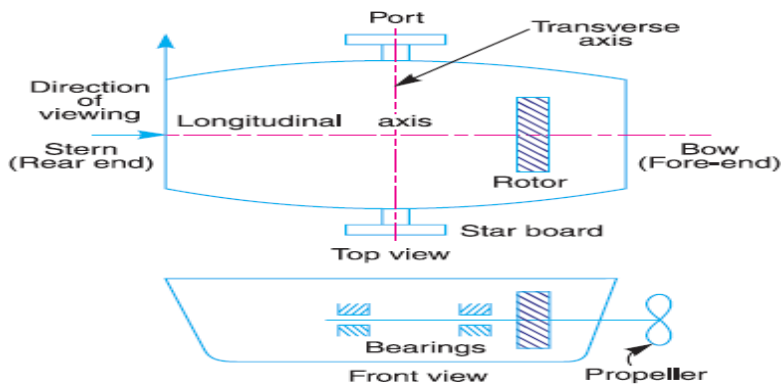

## Effect of Gyroscopic Couple on a Naval Ship during Steering

Steering is the turning of a complete ship in a curve towards left or right, while it moves forward. Consider the ship taking a left turn, and rotor rotates in the clockwise direction when viewed from the stern, as shown in Fig. The effect of gyroscopic couple on a naval ship during steering taking left or right turn may be obtained in the similar way as for an aeroplane.

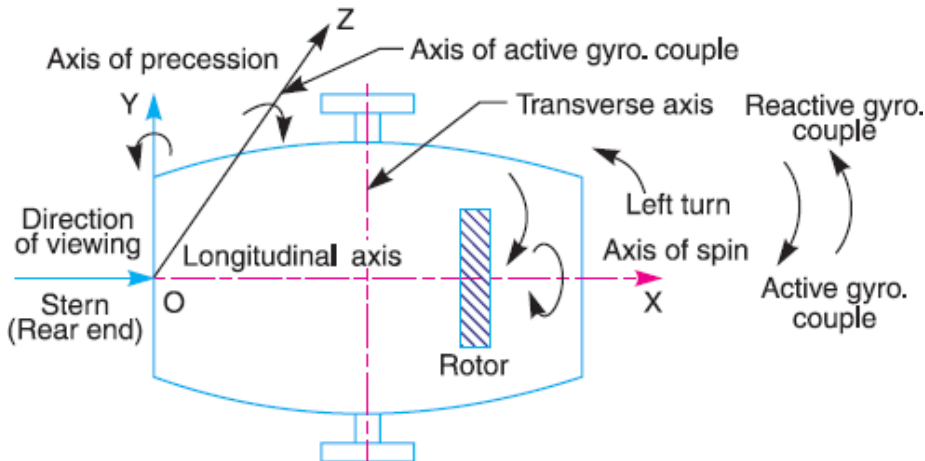

When the rotor of the ship rotates in the clockwise direction when viewed from the stern, it will have its angular momentum vector in the direction  $ox$  as shown in Fig(a). As the ship steers to the left, the active gyroscopic couple will change the angular momentum vector from  $ox$  to  $ox'$ . The vector  $xx'$  now represents the active gyroscopic couple and is perpendicular to  $ox$ . Thus the plane of active gyroscopic couple is perpendicular to  $xx'$  and its direction in the axis  $OZ$  for left hand turn is clockwise as shown in Fig. The reactive gyroscopic couple of the same magnitude will act in the opposite direction (i.e. in anticlockwise direction). The effect of this reactive gyroscopic couple is to raise the bow and lower the stern.

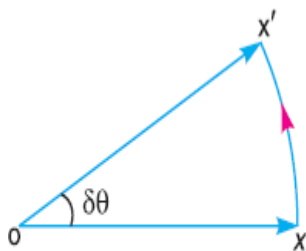

(a) Steering to the left

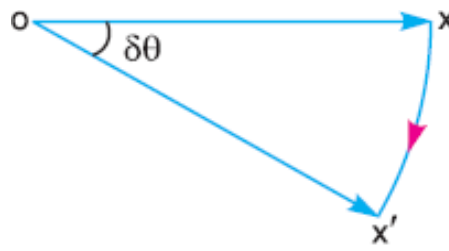

(b) Steering to the right



## Effect of Gyroscopic Couple on a Naval Ship during Pitching

Pitching is the movement of a complete ship up and down in a vertical plane about transverse axis, as shown in Fig(a). In this case, the transverse axis is the axis of precession. The pitching of the ship is assumed to take place with simple harmonic motion i.e. the motion of the axis of spin about transverse

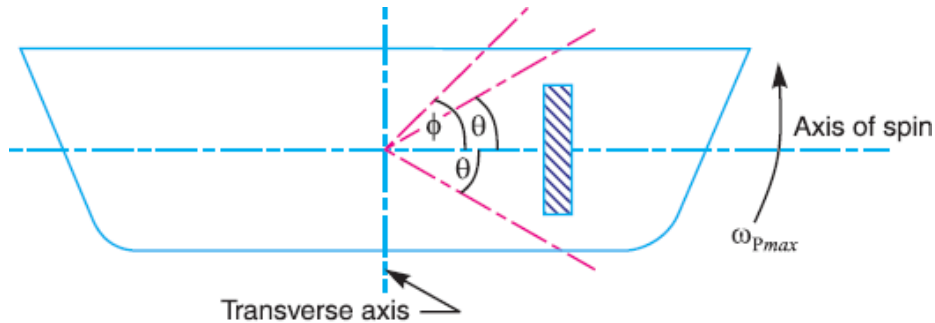

(a) Pitching of a naval ship

axis is simple harmonic.

Let  $I$  = Moment of inertia of the rotor in  $\text{kg-m}^2$ , and  $\omega$  = Angular velocity of the rotor in  $\text{rad/s}$ .

Minimum gyroscopic couple,

$$C_{max} = I. \omega. \omega_{Pmax}$$

When the pitching is upward, the effect of the reactive gyroscopic couple, as shown in Fig.(b), will try to move the ship toward star-board. On the other hand, if the pitching is downward, the effect of the reactive gyroscopic couple, as shown in Fig(c), is to turn the ship towards port side.

## Effect of Gyroscopic Couple on a Naval Ship during Rolling

We know that, for the effect of gyroscopic couple to occur, the axis of precession should always be perpendicular to the axis of spin. If, however, the axis of precession becomes parallel to the axis of spin, there will be no effect of the gyroscopic couple acting on the body of the ship.

In case of rolling of a ship, the axis of precession (*i.e.* longitudinal axis) is always parallel to the axis of spin for all positions. Hence, there is no effect of the gyroscopic couple acting on the body of a ship.

## Stability of a Four Wheel Drive Moving in a Curved Path



Consider the four wheels  $A$ ,  $B$ ,  $C$  and  $D$  of an automobile locomotive taking a turn towards left as shown in Fig. The wheels  $A$  and  $C$  are inner wheels, whereas  $B$  and  $D$  are outer wheels. The centre of gravity (C.G.) of the vehicle lies vertically above the road surface.

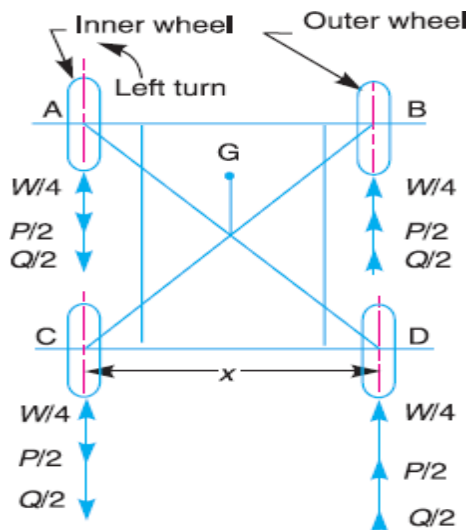

Let  $m$  = Mass of the vehicle in kg,

$W$  = Weight of the vehicle in newtons =  $m.g$ ,  $r_w$  = Radius of the wheels in metres,

$R$  = Radius of curvature in metres ( $R > r_w$ ),

$h$  = Distance of centre of gravity, vertically above the road surface in metres,

$x$  = Width of track in metres,

$I_w$  = Mass moment of inertia of one of the wheels in  $\text{kg}\cdot\text{m}^2$ ,

$\omega_w$  = Angular velocity of the wheels or velocity of spin in rad/s,

$I_E$  = Mass moment of inertia of the rotating parts of the engine in  $\text{kg}\cdot\text{m}^2$

$\omega_E$  = Angular velocity of the rotating parts of the engine in rad/s,

$G$  = Gear ratio =  $\omega_E/\omega_w$

$v$  = Linear velocity of the vehicle in m/s =  $\omega_w \cdot r_w$

A little consideration will show that the weight of the vehicle ( $W$ ) will be equally distributed over the four wheels which will act downwards. The reaction between each wheel and the road surface of the same magnitude will act upwards.



**Therefore Road reaction over each wheel =  $W/4 = m.g/4$  newtons**

Let us now consider the effect of the gyroscopic couple and centrifugal couple on the vehicle.

∴ Angular displacement of the axis of spin from mean position after time  $t$  seconds,

$$\theta = \phi \sin \omega_1 \cdot t$$

$\phi$  = Amplitude of swing *i.e.* maximum angle turned from the mean position in radians, and

$\omega_1$  = Angular velocity of S.H.M.

$$= \frac{2\pi}{\text{Time period of S.H.M. in seconds}} = \frac{2\pi}{t_p} \text{ rad/s}$$

Angular velocity of precession,

$$\omega_p = \frac{d\theta}{dt} = \frac{d}{dt}(\phi \sin \omega_1 \cdot t) = \phi \omega_1 \cos \omega_1 t$$

The angular velocity of precession will be maximum, if  $\cos \omega_1 t = 1$ .

∴ Maximum angular velocity of precession,

$$\omega_{pmax} = \phi \cdot \omega_1 = \phi \times 2\pi / t_p$$

...(Substituting  $\cos \omega_1 t = 1$ )

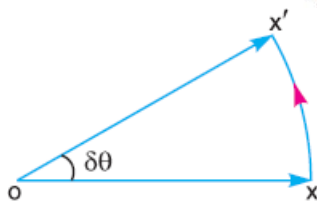

(b) Pitching upward

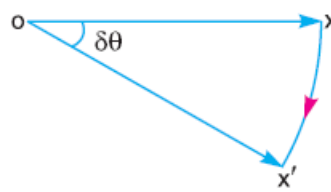

(c) Pitching downward

Effect of the gyroscopic couple

Since the vehicle takes a turn towards left due to the precession and other rotating parts, therefore a gyroscopic couple will act.

We know that velocity of precession,  $\omega_p = v/R$

Gyroscopic couple due to 4 wheels,

$$C_W = 4 I_W \cdot \omega_W \cdot \omega_p$$

and gyroscopic couple due to the rotating parts of the engine,

$$C_E = I_E \cdot \omega_E \cdot \omega_p = I_E \cdot G \cdot \omega_W \cdot \omega_p$$

Net gyroscopic couple,

$$C = C_W \pm C_E = 4 I_W \cdot \omega_W \cdot \omega_p \pm I_E \cdot G \cdot \omega_W \cdot \omega_p$$



$$= \omega_W \cdot \omega_P (4 I_W \pm G \cdot I_E)$$

The **positive** sign is used when the wheels and rotating parts of the engine rotate in the same direction. If the rotating parts of the engine revolve in opposite direction, then **negative** sign is used.

Due to the gyroscopic couple, vertical reaction on the road surface will be produced. The reaction will be vertically upwards on the outer wheels and vertically downwards on the inner wheels.

Let the magnitude of this reaction at the two outer or inner wheels be  $P$  new tons. Then

$$P \times x = C \text{ or } P = C/x$$

Vertical reaction at each of the outer or inner wheels,

$$P / 2 = C/2x$$

Effect of the centrifugal couple

Since the vehicle moves along a curved path, therefore centrifugal force will act outwardly at the centre of gravity of the vehicle. The effect of this centrifugal force is also to overturn the vehicle.

$$F_C = \frac{m \times v^2}{R}$$

We know that centrifugal force,

The couple tending to overturn the vehicle or overturning couple,

$$C_O = F_C \times h = \frac{m \cdot v^2}{R} \times h$$

This overturning couple is balanced by vertical reactions, which are vertically up wards on the outer wheels and vertically downwards on the inner wheels. Let the magnitude of this reaction at the two outer

$$Q \times x = C_O \text{ or } Q = \frac{C_O}{x} = \frac{m \cdot v^2 \cdot h}{R \cdot x}$$

or inner wheels be  $Q$ . Then

Vertical reaction at each of the outer or inner wheels,

Total vertical reaction at each of the outer wheel,

$$\frac{Q}{2} = \frac{m \cdot v^2 \cdot h}{2R \cdot x}$$



$$P_0 = \frac{W}{4} + \frac{P}{2} + \frac{Q}{2}$$

Total vertical reaction at each of the inner wheel

$$P_1 = \frac{W}{4} - \frac{P}{2} - \frac{Q}{2}$$

A little consideration will show that when the vehicle is running at high speeds,  $P_1$  may be zero or even negative. This will cause the inner wheels to leave the ground thus tending to overturn the automobile. In order to have the contact between the inner wheels and the ground, the sum of  $P/2$  and  $Q/2$  must be less than  $W/4$ .

### Stability of a Two Wheel Vehicle Taking a Turn

Consider a two wheel vehicle (say a scooter or motor cycle) taking a right turn as shown in fig.

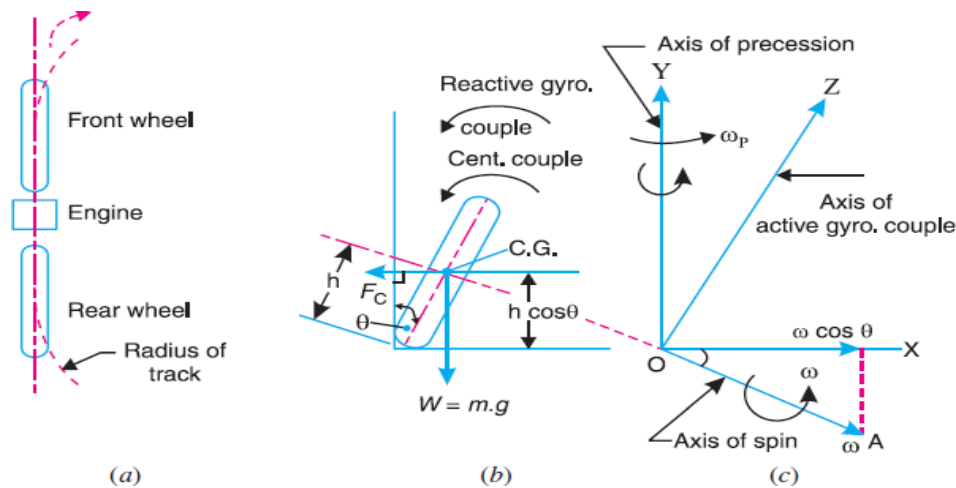

Let

$m$  = Mass of the vehicle and its rider in kg,

$W$  = Weight of the vehicle and its rider in Newton's =  $m.g$ ,  $h$  = Height of the centre of gravity of the vehicle and rider,  $r_w$  = Radius of the wheels,

$R$  = Radius of track or curvature,

$I_w$  = Mass moment of inertia of each wheel,

$I_E$  = Mass moment of inertia of the rotating parts of the engine,  $\omega_w$  = Angular velocity of the wheels,

$\omega_E$  = Angular velocity of the engine,

$$G = \text{Gear ratio} = \omega_E / \omega_w,$$



$v =$  Linear velocity of the vehicle  $= \omega_W \times r_W$ ,

$\theta =$  Angle of wheel. It is inclination of the vehicle to the vertical for equilibrium.

Let us now consider the effect of the gyroscopic couple and centrifugal couple on the vehicle,

Effect of gyroscopic couple

$$\omega_E = G \cdot \omega_W = G \times \frac{v}{r_W}$$

$$\begin{aligned} \therefore \text{Total } (I \times \omega) &= 2 I_W \times \omega_W \pm I_E \times \omega_E \\ &= 2 I_W \times \frac{v}{r_W} \pm I_E \times G \times \frac{v}{r_W} = \frac{v}{r_W} (2 I_W \pm G I_E) \end{aligned}$$

We know that  $v = \omega_W \times r_W$  or  $\omega_W = v / r_W$

Velocity of precession,  $\omega_P = v / R$

A little consideration will show that when the wheels move over the curved path, the vehicle is always inclined at an angle  $\theta$  with the vertical plane as shown in Fig (b). This angle is known as **angle of heel**. In other words, the axis of spin is inclined to the horizontal at an angle  $\theta$ , as shown in Fig (c). Thus the angular

Momentum vector  $I\omega$  due to spin is represented by  $OA$  inclined to  $OX$  at an angle  $\theta$ . But the precession

Gyroscopic couple,

$$\begin{aligned} C_1 &= I \cdot \omega \cos \theta \times \omega_P = \frac{v}{r_W} (2 I_W \pm G I_E) \cos \theta \times \frac{v}{R} \\ &= \frac{v^2}{R \cdot r_W} (2 I_W \pm G I_E) \cos \theta \end{aligned}$$

axis is vertical. Therefore the spin vector is resolved along  $OX$ .

Effect of centrifugal couple

We know that centrifugal force,

$$F_C = \frac{m \cdot v^2}{R}$$

This force acts horizontally through the centre of gravity (C.G.) along the outward direction.

$$C_2 = F_C \times h \cos \theta = \left( \frac{m \cdot v^2}{R} \right) h \cos \theta$$



Centrifugal couple,

Since the centrifugal couple has a tendency to overturn the vehicle, therefore Total overturning couple,

$C_O = \text{Gyroscopic couple} + \text{Centrifugal couple}$

$$\begin{aligned} &= \frac{v^2}{R.r_W} (2 I_W + G.I_E) \cos \theta + \frac{m.v^2}{R} \times h \cos \theta \\ &= \frac{v^2}{R} \left[ \frac{2 I_W + G.I_E}{r_W} + m.h \right] \cos \theta \end{aligned}$$

We know that balancing couple =  $m.g.h \sin \theta$

The balancing couple acts in clockwise direction when seen from the front of the vehicle. Therefore for stability, the overturning couple must be equal to the balancing couple, *i.e.*

$$\frac{v^2}{R} \left( \frac{2 I_W + G.I_E}{r_W} + m.h \right) \cos \theta = m.g.h \sin \theta$$

From this expression, the value of the angle of heel ( $\theta$ ) may be determined, so that the vehicle does not skid.

## PROBLEMS

### Example 1.

A uniform disc of diameter 300 mm and of mass 5 kg is mounted on one end of an arm of length 600 mm. The other end of the arm is free to rotate in a universal bearing. If the disc rotates about the arm with a speed of 300 r.p.m. clockwise, looking from the front, with what speed will it precess about the vertical axis?

**Solution.** Given:  $d = 300 \text{ mm}$  or  $r = 150 \text{ mm} = 0.15 \text{ m}$  ;  $m = 5 \text{ kg}$  ;  $l = 600 \text{ mm} = 0.6 \text{ m}$   
 $N = 300 \text{ r.p.m.}$  or  $\omega = 2\pi \times 300/60 = 31.42 \text{ rad/s}$

We know that the mass moment of inertia of the disc, about an axis through its centre of gravity and perpendicular to the plane of disc,

$$I = m.r^2/2 = 5(0.15)^2/2 = 0.056 \text{ kg-m}^2$$

couple due to mass of disc,

$$C = m.g.l = 5 \times 9.81 \times 0.6 = 29.43 \text{ N-m}$$

Let  $\omega_P = \text{Speed of precession.}$

We know that couple (C),



$$29.43 = I \cdot \omega \cdot \omega_p = 0.056 \times 31.42 \times \omega_p = 1.76 \omega_p$$

$$\omega_p = 29.43/1.76 = 16.7 \text{ rad/s}$$

### Example 2.

An aeroplane makes a complete half circle of 50 metres radius, towards left, when flying at 200 km per hr. The rotary engine and the propeller of the plane has a mass of 400 kg and a radius of gyration of 0.3 m. The engine rotates at 2400 r.p.m. clockwise when viewed from the rear. Find the gyroscopic couple on the aircraft and state its effect on it.

**Solution:** Given :  $R = 50 \text{ m}$  ;  $v = 200 \text{ km/hr} = 55.6 \text{ m/s}$  ;  $m = 400 \text{ kg}$  ;  $k = 0.3 \text{ m}$  ;  $N =$

**2400 r.p.m. or  $\omega = 2\pi \times 2400/60 = 251 \text{ rad/s}$**

We know that mass moment of inertia of the engine and the propeller,

$$I = m \cdot k^2 = 400(0.3)^2 = 36 \text{ kg-m}^2$$

Angular velocity of precession,  $\omega_p = v/R = 55.6/50 = 1.11 \text{ rad/s}$

We know that gyroscopic couple acting on the aircraft,

$$C = I \cdot \omega \cdot \omega_p = 36 \times 251.4 \times 1.11 = 10046 \text{ N-m} = 10.046 \text{ kN-m}$$

When the aeroplane turns towards left, the effect of the gyroscopic couple is to lift the nose upwards and tail downwards.

**Example 3 :** The turbine rotor of a ship has a mass of 8 tonnes and a radius of gyration 0.6 m. It rotates at 1800 r.p.m. clockwise, when looking from the stern. Determine the gyroscopic couple, if the ship travels at 100 km/hr and steer to the left in a curve of 75 m radius.

**Solution.** Given:  $m = 8 \text{ t} = 8000 \text{ kg}$  ;  $k = 0.6 \text{ m}$  ;  $N = 1800 \text{ r.p.m. or } \omega = 2\pi \times 1800/60 = 188.5 \text{ rad/s}$  ;  
 $v = 100 \text{ km/h} = 27.8 \text{ m/s}$  ;  $R = 75 \text{ m}$

We know that mass moment of inertia of the rotor,

$$I = m \cdot k^2 = 8000 (0.6)^2 = 2880 \text{ kg-m}^2$$

Angular velocity of precession,

$$\omega_p = v / R = 27.8 / 75 = 0.37 \text{ rad/s}$$

We know that gyroscopic

$$C = I \cdot \omega \cdot \omega_p = 2880 \times 188.5 \times 0.37 = 200866 \text{ N-m}$$

$$= 200.866 \text{ kN-m}$$



When the rotor rotates in clockwise direction when looking from the stern and the ship steers to the left, the effect of the reactive gyroscopic couple is to raise the bow and lower the stern.



## INDUSTRIAL APPLICATIONS OF GYROSCOPIC

1. Motor car
2. Motor cycle
3. Aero planes
4. Ships

5. Applications of gyroscopes include inertial navigation systems, such as in the Hubble Telescope, or inside the steel hull of a submerged submarine. Due to their precision, gyroscopes are also used in gyrotheodolites to maintain direction in tunnel mining.

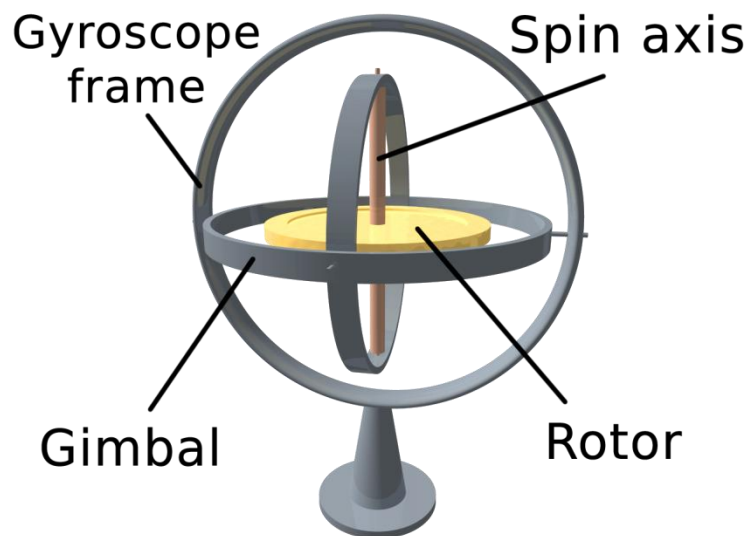

## Gyroscopic Effect ( Simple Trick )

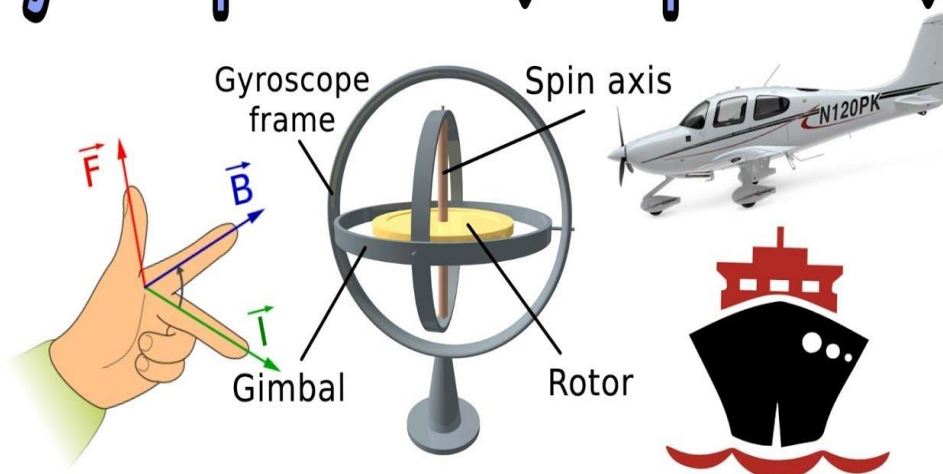

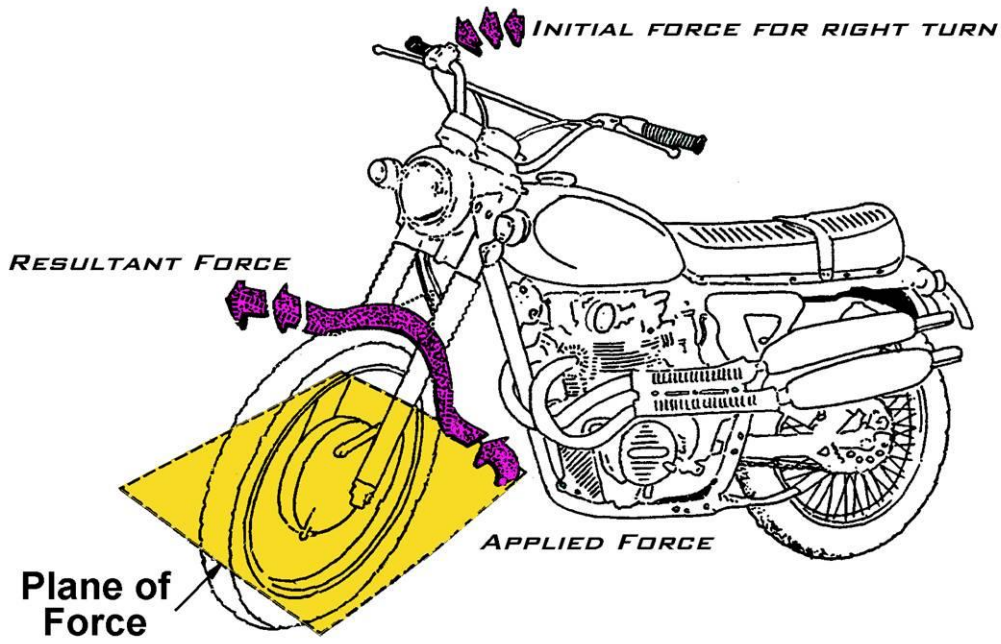

## TUTORIAL QUESTIONS

1. What do you understand by gyroscopic couple? Derive a formula for its magnitude.
2. Explain the effect of the gyroscopic couple on the reaction of the four wheels of a vehicle negotiating a curve.
3. Discuss the effect of the gyroscopic couple on a two wheeled vehicle when taking a turn.
4. What will be the effect of the gyroscopic couple on a disc fixed at a certain angle to a rotating shaft?
5. A flywheel of mass 10 kg and radius of gyration 200 mm is spinning about its axis, which is horizontal and is suspended at a point distant 150 mm from the plane of rotation of the flywheel. Determine the angular velocity of precession of the flywheel. The spin speed of flywheel is 900 r.p.m.
6. Find the angle of inclination with respect to the vertical of a two wheeler negotiating a turn. Given : combined mass of the vehicle with its rider 250 kg ; moment of inertia of the engine flywheel 0.3 kg-m<sup>2</sup> ; moment of inertia of each road wheel 1 kg-m<sup>2</sup> ; speed of engine flywheel 5 times that of road wheels and in the same direction ; height of centre of gravity of rider with vehicle 0.6 m ; two wheeler speed 90 km/h ; wheel radius 300 mm ; radius of turn 50 m.
7. A pair of locomotive driving wheels with the axle, have a moment of inertia of 180 kg-m<sup>2</sup>. The diameter of the wheel treads is 1.8 m and the distance between wheel centres is 1.5 m. When the locomotive is travelling on a level track at 95 km/h, defective ballasting causes one wheel to fall 6 mm and to rise again in a total time of 0.1 s. If the displacement of the wheel takes place with simple harmonic motion, find: 1. The gyroscopic couple set up, and 2. The reaction between the wheel and rail due to this couple.
8. A four-wheeled trolley car of total mass 2000 kg running on rails of 1.6 m gauge, rounds a curve of 30 m radius at 54 km/h. The track is banked at 8°. The wheels have an external diameter of 0.7 m and each pair with axle has a mass of 200 kg. The radius of gyration for each pair is 0.3 m. The height of centre of gravity of the car above the wheel base is 1 m. Determine, allowing for centrifugal force and gyroscopic couple actions, the pressure on each rail.
9. A horizontal axle AB, 1 m long, is pivoted at the midpoint C. It carries a weight of 20 N at A and a wheel weighing 50 N at B. The wheel is made to spin at a speed of 600 r.p.m in a clockwise direction looking from its front. Assuming that the weight of the flywheel is uniformly distributed around the rim whose mean diameter is 0.6 m; calculate the angular velocity of precession of the system around the vertical axis through C.



## ASSIGNMENT QUESTIONS

1. Explain the effect of the gyroscopic couple on the reaction of the four wheels of a vehicle negotiating a curve
2. Discuss the effect of the gyroscopic couple on a two wheeled vehicle when taking a turn.
3. What will be the effect of the gyroscopic couple on a disc fixed at a certain angle to a rotating shaft?
4. A uniform disc of 150 mm diameter has a mass of 5 kg. It is mounted centrally in bearings which maintain its axle in a horizontal plane. The disc spins about its axle with a constant speed of 1000 r.p.m. while the axle precesses uniformly about the vertical at 60 r.p.m. The directions of rotation are as shown in Fig. 14.3. If the distance between the bearings is 100 mm, find the resultant reaction at each bearing due to the mass and gyroscopic effects.
5. An aeroplane makes a complete half circle of 50 metres radius, towards left, when flying at 200 km per hr. The rotary engine and the propeller of the plane has a mass of 400 kg and a radius of gyration of 0.3 m. The engine rotates at 2400 r.p.m. clockwise when viewed from the rear. Find the gyroscopic couple on the aircraft and state its effect on it.
6. The turbine rotor of a ship has a mass of 8 tonnes and a radius of gyration 0.6 m. It rotates at 1800 r.p.m. clockwise, when looking from the stern. Determine the gyroscopic couple, if the ship travels at 100 km/hr and steers to the left in a curve of 75 m radius.
7. The heavy turbine rotor of a sea vessel rotates at 1500 r.p.m. clockwise looking from the stern, its mass being 750 kg. The vessel pitches with an angular velocity of 1 rad/s. Determine the gyroscopic couple transmitted to the hull when bow is rising, if the radius of gyration for the rotor is 250 mm. Also show in what direction the couple acts on the hull?
8. The turbine rotor of a ship has a mass of 3500 kg. It has a radius of gyration of 0.45 m and a speed of 3000 r.p.m. clockwise when looking from stern. Determine the gyroscopic couple and its effect upon the ship:
  1. when the ship is steering to the left on a curve of 100 m radius at a speed of 36 km/h.
  2. when the ship is pitching in a simple harmonic motion, the bow falling with its maximum velocity. The period of pitching is 40 seconds and the total angular displacement between the two extreme positions of pitching is 12 degrees.
9. A ship propelled by a turbine rotor which has a mass of 5 tonnes and a speed of 2100 r.p.m. The rotor has a radius of gyration of 0.5 m and rotates in a clockwise direction when viewed from the stern. Find the gyroscopic effects in the following conditions:



1. The ship sails at a speed of 30 km/h and steers to the left in a curve having 60 m radius.
2. The ship pitches 6 degree above and 6 degree below the horizontal position. The bow is descending with its maximum velocity. The motion due to pitching is simple harmonic and the periodic time is 20 seconds.
3. The ship rolls and at a certain instant it has an angular velocity of 0.03 rad/s clockwise when viewed from stern.

Determine also the maximum angular acceleration during pitching. Explain how the direction of motion due to gyroscopic effect is determined in each case.





---

## UNIT 2

### STATIC AND DYNAMICS FORCE ANALYSIS OF PLANNER MECHANISMS /FRICTION IN MACHINE MECHANISMS

---



## **Course Objectives**

To understand the force-motion relationship in components subjected to external forces and analysis of standard mechanisms.

## **Course Outcomes**

Able to predict the force analysis in mechanical system and able to solve the problem.



## Introduction:

Then the system can be treated as static, which permits application of. Techniques of static force analysis. Dynamic force analysis is the evaluation of input forces or torques and joint forces. Considering motion of members. Evaluation of the inertia force /torque is explained first.

The inertia force is an imaginary force, which when acts upon a rigid body, brings it in an equilibrium position. It is numerically equal to the accelerating force in magnitude, but opposite in direction. Mathematically,

$$\text{Inertia force} = - \text{Accelerating force} = - m.a$$

Where  $m$  = Mass of the body, and

$a$  = Linear acceleration of the centre of gravity of the body.

Similarly, the inertia torque is an imaginary torque, which when applied upon the rigid body, brings it in equilibrium position. It is equal to the accelerating couple in magnitude but opposite in direction.

Resultant Effect of a System of Forces Acting on a Rigid Body:

Consider a rigid body acted upon by a system of forces. These forces may be reduced to a single resultant force  $F$  whose line of action is at a distance  $h$  from the centre of gravity  $G$ . Now let us assume two equal and opposite forces (of magnitude  $F$ ) acting through  $G$ , and parallel to the resultant force, without influencing the effect of the resultant force  $F$ , as shown in Fig. 15.1. A little consideration will show that the body is now subjected to a couple (equal to  $F \times h$ ) and a force; equal and parallel to the resultant force  $F$  passing through  $G$ . The force  $F$  through  $G$  causes linear acceleration of the c.g. and the moment of the couple ( $F \times h$ ) causes angular acceleration of the body about an axis passing through  $G$  and perpendicular to the point in which the couple acts.

$\alpha$  = Angular acceleration of the rigid body due to couple,

$h$  = Perpendicular distance between the force and centre of gravity of the body,

$m$  = Mass of the body,

$k$  = Least radius of gyration about an axis through  $G$ , and

$I$  = Moment of inertia of the body about an axis passing through its centre of gravity and perpendicular to the point in which the couple acts =  $m.k^2$

We know that Force,

$$F = \text{Mass} \times \text{Acceleration} = m.a \dots(i) \text{ and}$$

$$F.h = m.k^2.\alpha = I.\alpha$$

## D-Alembert's Principle



Consider a rigid body acted upon by a system of forces. The system may be reduced to a single resultant force acting on the body whose magnitude is given by the product of the mass of the body and the linear acceleration of the centre of mass of the body. According to Newton's second law of motion.  $F = m.a$  ... (i)

Where  $F$  = Resultant force acting on the body,

$m$  = Mass of the body, and

$a$  = Linear acceleration of the centre of mass of the body

The equation (i) may also be written as:

$$F - m.a = 0$$

A little consideration will show, that if the quantity  $-m.a$  be treated as a force, equal, opposite and with the same line of action as the resultant force  $F$ , and include this force with the system of forces of which  $F$  is the resultant, then the complete system of forces will be in equilibrium. This principle is known as D'Alembert's principle. The equal and opposite force  $-m.a$  is known as reversed effective force or the inertia force (briefly written as  $F_I$ ). The equation (ii) may be written as  $F + F_I = 0$  ... (iii)

Thus, D'Alembert's principle states that the resultant force acting on a body together with the reversed effective force (or inertia force), are in equilibrium. This principle is used to reduce a dynamic problem into an equivalent static problem.

Friction in Machine Elements

## Screw Friction

The screws, bolts, studs, nuts etc. are widely used in various machines and structures for temporary fastenings. These fastenings have screw threads, which are made by cutting a continuous helical groove on a cylindrical surface. If the threads are cut on the outer surface of a solid rod, these are known as external threads. But if the threads are cut on the internal surface of a hollow rod, these are known as internal threads. The screw threads are mainly of two types i.e. V-threads and square threads. The V-threads are stronger and offer more frictional resistance to motion than square threads. Moreover, the V-threads have an advantage of preventing the nut from slackening. In general, the V threads are used for the purpose of tightening pieces together e.g. bolts and nuts etc. But the square threads are used in screw jacks, vice screws etc. The following terms are important for the study of screw

**Helix.** It is the curve traced by a particle, while describing a circular path at a uniform speed and advancing in the axial direction at a uniform rate. In other words, it is the curve traced by a particle while moving along a screw thread.

**Pitch.** It is the distance from a point of a screw to a corresponding point on the next thread, measured parallel to the axis of the screw



Lead. It is the distance; a screw thread advances axially in one turn.

**Depth of thread.** It is the distance between the top and bottom surfaces of a thread (also known as crest and root of a thread).

Single-threaded screw. If the lead of a screw is equal to its pitch. It is known as single threaded screw.

**Lead = Pitch × Number of threads**

**Helix angle.** It is the slope or inclination of the thread with the horizontal.

The screw jack is a device, for lifting heavy loads, by applying a comparatively smaller effort at its handle.

The principle, on which a screw jack works, is similar to that of an inclined plane.

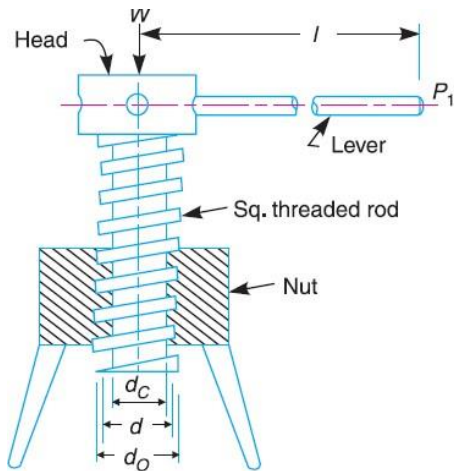

(a) Screw jack.

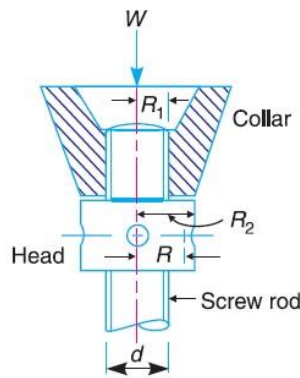

(b) Thrust collar.

Fig (a) shows a common form of a screw jack, which consists of a square threaded rod (also called screw rod or simply screw) which fits into the inner threads of the nut. The load, to be raised or lowered, is placed on the head of the square threaded rod which is rotated by the application of an effort at the end of the lever for lifting or lowering the load.

**Torque Required to Lifting the Load by a Screw Jack :**

If one complete turn of a screw thread by imagined to be unwound, from the body of the screw and developed, it will form an inclined plane as shown in Fig (a).

Let  $p$  = Pitch of the screw,

$d$  = Mean diameter of the screw,  $\alpha$  = Helix angle,

$P$  = Effort applied at the circumference of the screw to lift the load,

$W$  = Load to be lifted, and

$\mu$  = Coefficient of friction, between the screw and nut =  $\tan \phi$ , Where  $\phi$  is the friction angle.

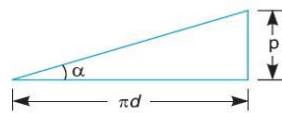

(a) Development of a screw.

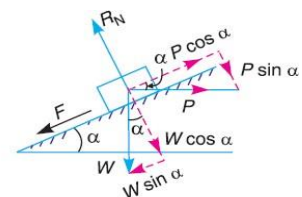

(b) Forces acting on the screw.



From the geometry of the Fig(a), we find that

$$\tan \alpha = p/\pi d$$

Since the principle on which a screw jack works is similar to that of an inclined plane, therefore the force applied on the lever of a screw jack may be considered to be horizontal as shown in Fig(b).

Since the load is being lifted, therefore the force of friction ( $F = \mu.RN$ ) will act downwards. All the forces acting on the screw are shown in Fig(b). Resolving the forces along the plane,

$$P \cos \alpha = W \sin \alpha + F = W \sin \alpha + \mu.RN \quad (i)$$

and resolving the forces perpendicular to the plane,

$$RN = P \sin \alpha + W \cos \alpha \quad (ii) \text{ Substituting this value of } RN \text{ in equation (i),}$$

$$P \cos \alpha = W \sin \alpha + \mu (P \sin \alpha + W \cos \alpha)$$

$$= W \sin \alpha + \mu P \sin \alpha + \mu W \cos \alpha$$

$$P \cos \alpha - \mu P \sin \alpha = W \sin \alpha + \mu W \cos \alpha$$

$$P (\cos \alpha - \mu \sin \alpha) = W (\sin \alpha + \mu \cos \alpha)$$

$$P = W \times \frac{\sin \alpha + \mu \cos \alpha}{\cos \alpha - \mu \sin \alpha}$$

Substituting the value of  $\mu = \tan \phi$  in the above equation, we get

$$P = W \times \frac{\sin \alpha + \tan \phi \cos \alpha}{\cos \alpha - \tan \phi \sin \alpha}$$

Multiplying the numerator and denominator by  $\cos \phi$ ,

$$P = W \times \frac{\sin \alpha \cos \phi + \sin \phi \cos \alpha}{\cos \alpha \cos \phi - \sin \alpha \sin \phi} = W \times \frac{\sin (\alpha + \phi)}{\cos (\alpha + \phi)}$$

$$= W \tan (\alpha + \phi)$$

$$T_1 = P \times \frac{d}{2} = W \tan (\alpha + \phi) \frac{d}{2}$$

Torque required to overcoming friction between the screw and nut,

When the axial load is taken up by a thrust collar or a flat surface, as shown in Fig (b), so that the load does not rotate with the screw, then the torque required to overcome friction at the collar,



$$T_2 = \mu_1 \cdot W \left( \frac{R_1 + R_2}{2} \right) = \mu_1 \cdot W \cdot R$$

$R_1$  and  $R_2$  = Outside and inside radii of the collar,

$R$  = Mean radius of the collar, and

$\mu_1$  = Coefficient of friction for the collar.

$$T = T_1 + T_2 = P \times \frac{d}{2} + \mu_1 \cdot W \cdot R$$

Total torque required to overcome friction (*i.e.* to rotate the screw),

If an effort  $P_1$  is applied at the end of a lever of arm length  $l$ , then the total torque required to overcome friction must be equal to the torque applied at the end of the lever, *i.e.*

$$T = P \times \frac{d}{2} = P_1 \cdot l$$

Friction of a V-thread

The normal reaction in case of a square threaded screw is

$R_N = W \cos \alpha$ , where  $\alpha$  = Helix angle.

But in case of V-thread (or acme or trapezoidal threads), the normal reaction between the screw and nut is increased because the axial component of this normal reaction must be equal to the axial load.

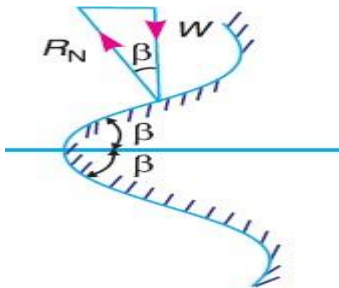

$W$ , as shown in Fig.

Let  $2\beta$  = Angle of the V-thread, and

$$R_N = \frac{W}{\cos \beta}$$

$$\text{frictional force, } F = \mu \cdot R_N = \mu \times \frac{W}{\cos \beta} = \mu_1 \cdot W$$



$\beta$  = Semi-angle of the V-thread.

### Friction in Journal Bearing-Friction Circle

A journal bearing forms a turning pair as shown in Fig (a). The fixed outer element of a turning pair is

$$\frac{\mu}{\cos \beta} = \mu_1, \text{ known as virtual coefficient of friction.}$$

called a **bearing** and that portion of the inner element (*i.e.* shaft) which fits in the bearing is called a **journal**. The journal is slightly less in diameter than the bearing, in order to permit the free movement of the journal in a bearing.

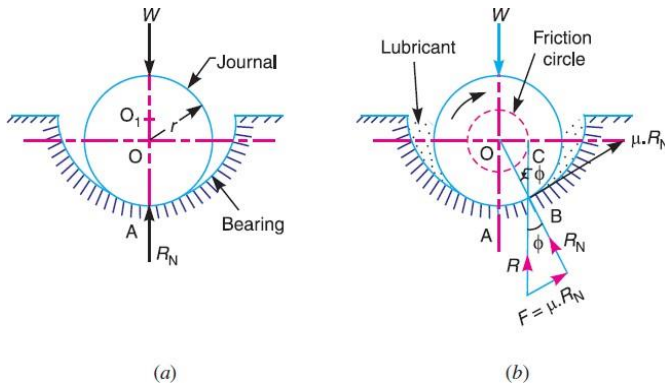

When the bearing is not lubricated (or the journal is stationary), then there is a line contact between the two elements as shown in Fig (a). The load  $W$  on the journal and normal reaction  $R_N$  (equal to  $W$ ) of the bearing acts through the centre. The reaction  $R_N$  acts vertically upwards at point  $A$ . This point  $A$  is known as **seat or point of pressure**.

Now consider a shaft rotating inside a bearing in clockwise direction as shown in Fig(b). The lubricant between the journal and bearing forms a thin layer which gives rise to a greasy friction. Therefore, the reaction  $R$  does not act vertically upward, but acts at another point of pressure  $B$ . This is due to the fact that when shaft rotates, a frictional force  $F = \mu R_N$  acts at the circumference of the shaft which has a tendency to rotate the shaft in opposite direction of motion and this shifts the point  $A$  to point  $B$ . In order that the rotation may be maintained, there must be a couple rotating the shaft.

Let  $\phi$  = Angle between  $R$  (resultant of  $F$  and  $R_N$ ) and  $R_N$ ,

$\mu$  = Coefficient of friction between the journal and bearing,

$T$  = Frictional torque in N-m, and

$r$  = Radius of the shaft in meters.

For uniform motion, the resultant force acting on the shaft must be zero and the resultant turning moment on the shaft must be zero. In other words,



$$R = W, \text{ and } T = W \times OC = W \times OB \sin\phi = W.r \sin\phi$$

Since  $\phi$  is very small, therefore substituting  $\sin\phi = \tan\phi$

$$T = W.r \tan\phi = \mu.W.r \quad (\mu = \tan\phi)$$

If the shaft rotates with angular velocity  $\omega$  rad/s, then power wasted in friction,

$$P = T\omega = T \times 2\pi N/60 \text{ watts Where } N = \text{Speed of the shaft in r.p.m.}$$

### Friction of Pivot and Collar Bearing

The rotating shafts are frequently subjected to axial thrust. The bearing surfaces such as pivot and collar bearings are used to take this axial thrust of the rotating shaft. The propeller shafts of ships, the shafts of steam turbines, and vertical machine shafts are examples of shafts which carry an axial thrust. The bearing surfaces placed at the end of a shaft to take the axial thrust are known as pivots. The pivot may have a flat surface or conical surface as shown in Fig. 10.16 (a) and (b) respectively. When the cone is truncated, it is then known as truncated or trapezoidal pivot as shown in Fig (c).

The collar may have flat bearing surface or conical bearing surface, but the flat surface is most commonly used. There may be a single collar, as shown in Fig (d) or several collars along the length of a shaft, as shown in Fig(e) in order to reduce the intensity of pressure.

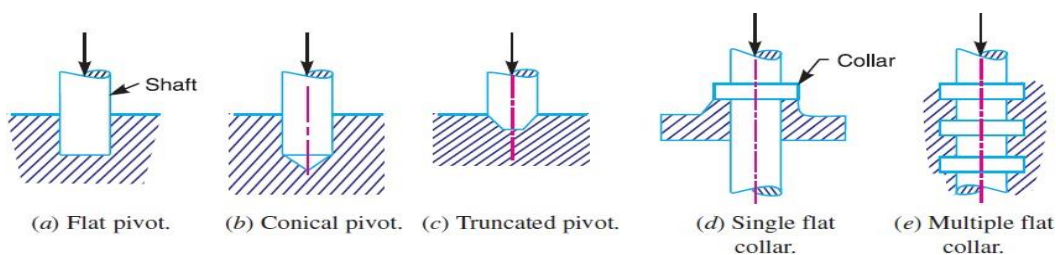

In modern practice, ball and roller thrust bearings are used when power is being transmitted and when thrusts are large as in case of propeller shafts of ships.

A little consideration will show that in a new bearing, the contact between the shaft and bearing may be good over the whole surface. In other words, we can say that the pressure over the rubbing surfaces is uniformly distributed. But when the bearing becomes old, all parts of the rubbing surface will not move with the same velocity, because the velocity of rubbing surface increases with the distance from the axis of the bearing. This means that wear may be different at different radii and this causes to alter the distribution of pressure. Hence, in the study of friction of bearings, it is assumed that

The pressure is uniformly distributed throughout the bearing surface, and

The wear is uniform throughout the bearing surface.



## Flat Pivot Bearing:

When a vertical shaft rotates in a flat pivot bearing (known as **foot step bearing**), as shown in Fig., the sliding friction will be along the surface of contact between the shaft and the bearing.

Let  $W$  = Load transmitted over the bearing surface,

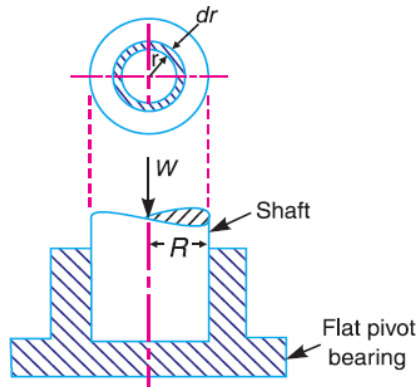

$R$  = Radius of bearing surface,

$p$  = Intensity of pressure per unit area of bearing surface between rubbing surfaces, and

$\mu$  = Coefficient of friction.

We will consider the following two cases:

1. When there is a uniform pressure
2. When there is a uniform wear

Considering uniform pressure

$$p = \frac{W}{\pi R^2}$$

When the pressure is uniformly distributed over the bearing area, then

Consider a ring of radius  $r$  and thickness  $dr$  of the bearing area. Area of bearing surface,  $A = 2\pi r \cdot dr$

Load transmitted to the ring,

$$\delta W = p \times A = p \times 2\pi r \cdot dr \quad (i)$$

Frictional resistance to sliding on the ring acting tangentially at radius  $r$ ,  $F_r = \mu \cdot \delta W = \mu p \times 2\pi r \cdot dr = 2\pi \mu \cdot p \cdot r \cdot dr$

Frictional torque on the ring,

$$T_r = F_r \times r = 2\pi \mu p r \cdot dr \times r = 2\pi \mu p r^2 dr \quad (ii)$$



Integrating this equation within the limits from 0 to  $R$  for the total frictional torque on the pivot bearing.

$$\begin{aligned} \therefore \text{Total frictional torque, } T &= \int_0^R 2\pi\mu p r^2 dr = 2\pi\mu p \int_0^R r^2 dr \\ &= 2\pi\mu p \left[ \frac{r^3}{3} \right]_0^R = 2\pi\mu p \times \frac{R^3}{3} = \frac{2}{3} \times \pi\mu \cdot p \cdot R^3 \\ &= \frac{2}{3} \times \pi\mu \times \frac{W}{\pi R^2} \times R^3 = \frac{2}{3} \times \mu \cdot W \cdot R \quad \dots \left( \because p = \frac{W}{\pi R^2} \right) \end{aligned}$$

When the shaft rotates at  $\omega$  rad/s, then power lost in friction,

$$P = T \cdot \omega = T \times 2\pi N/60 \quad \dots (\because \omega = 2\pi N/60)$$

$N$  = Speed of shaft in r.p.m.

### Considering uniform wear

We have already discussed that the rate of wear depends upon the intensity of pressure and the velocity of rubbing surfaces ( $v$ ). It is assumed that the rate of wear is proportional to the product of intensity of pressure and the velocity of rubbing surfaces (*i.e.*  $p \cdot v$ ). Since the velocity of rubbing surfaces increases with the distance (*i.e.* radius  $r$ ) from the axis of the bearing, therefore for uniform Wear



$$p.r = C \text{ (a constant) or } p = C/r$$

and the load transmitted to the ring,

$$\delta W = p \times 2\pi r.dr \quad \dots[\text{From equation (i)}]$$

$$= \frac{C}{r} \times 2\pi r.dr = 2\pi C.dr$$

∴ Total load transmitted to the bearing

$$W = \int_0^R 2\pi C.dr = 2\pi C[r]_0^R = 2\pi C.R \text{ or } C = \frac{W}{2\pi R}$$

We know that frictional torque acting on the ring,

$$T_r = 2\pi\mu p r^2 dr = 2\pi\mu \times \frac{C}{r} \times r^2 dr \quad \dots\left(\because p = \frac{C}{r}\right)$$

$$= 2\pi\mu.C.r dr \quad \dots(\text{iii})$$

∴ Total frictional torque on the bearing,

$$T = \int_0^R 2\pi\mu.C.r.dr = 2\pi\mu.C \left[ \frac{r^2}{2} \right]_0^R$$

$$= 2\pi\mu.C \times \frac{R^2}{2} = \pi\mu.C.R^2$$

$$= \pi\mu \times \frac{W}{2\pi R} \times R^2 = \frac{1}{2} \times \mu.W.R \quad \dots\left(\because C = \frac{W}{2\pi R}\right)$$

## PROBLEMS

**Example 1.** A vertical shaft 150 mm in diameter rotating at 100 r.p.m. rests on a flat end foot step bearing. The shaft carries a vertical load of 20 kN. Assuming uniform pressure distribution and coefficient of friction equal to 0.05, estimate power lost in friction.

**Solution.** Given :  $D = 150 \text{ mm}$  or  $R = 75 \text{ mm} = 0.075 \text{ m}$  ;  $N = 100 \text{ r.p.m}$  or  $\omega = 2\pi \times 100/60 = 10.47 \text{ rad/s}$  ;  $W = 20 \text{ kN} = 20 \times 10^3 \text{ N}$  ;  $\mu = 0.05$

We know that for uniform pressure distribution, the total frictional torque,

$$T = \frac{2}{3} \times \mu.W.R = \frac{2}{3} \times 0.05 \times 20 \times 10^3 \times 0.075 = 50 \text{ N-m}$$

∴ Power lost in friction,

$$P = T.\omega = 50 \times 10.47 = 523.5 \text{ W Ans.}$$

## Conical Pivot Bearing

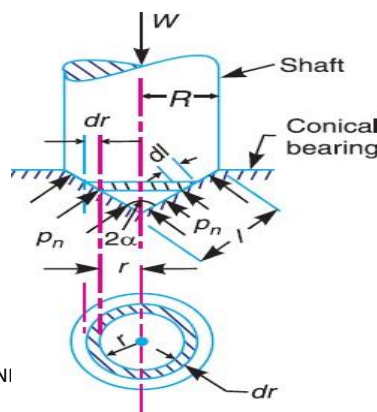

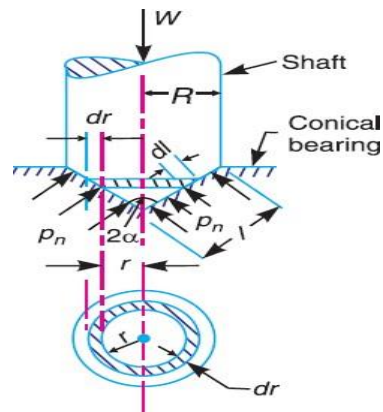

The conical pivot bearing supporting a shaft carrying a load  $W$  is shown in Fig. Let

$p_n$  = Intensity of pressure normal to the cone,

$\alpha$  = Semi angle of the cone,

$\mu$  = Coefficient of friction between the shaft and the bearing,

$R$  = Radius of the shaft.

Consider a small ring of radius  $r$  and thickness  $dr$ .

Let  $dl$  is the length of ring along the cone, such that

$$dl = dr \operatorname{cosec} \alpha$$

$$\text{Area of the ring, } A = 2\pi r \cdot dl = 2\pi r \cdot dr \operatorname{cosec} \alpha \quad (dl = dr \operatorname{cosec} \alpha)$$

Considering uniform pressure

We know that normal load acting on the ring,  $\delta W_n$  = Normal pressure  $\times$  Area

$$= p_n \times 2\pi r \cdot dr \operatorname{cosec} \alpha \quad \text{vertical load acting on the ring,}$$

$\delta W$  = Vertical component of  $\delta W_n$  =  $\delta W_n \cdot \sin \alpha$  Total vertical load transmitted to the bearing,

$$W = \int_0^R p_n \times 2\pi r \cdot dr = 2\pi p_n \left[ \frac{r^2}{2} \right]_0^R = 2\pi p_n \times \frac{R^2}{2} = \pi R^2 \cdot p_n$$

$$p_n = W / \pi R^2$$

$$T_r = F_r \times r = 2\pi \mu \cdot p_n \cdot \operatorname{cosec} \alpha \cdot r \cdot dr \times r = 2\pi \mu \cdot p_n \operatorname{cosec} \alpha \cdot r^2 \cdot dr$$

We know that frictional force on the ring acting tangentially at radius  $r$ ,

The vertical load acting on the ring is also given by  $\delta W$  = Vertical component of  $p_n \times$  Area of the ring



$$= p_n \sin \alpha \times 2\pi r \cdot dr \cdot \operatorname{cosec} \alpha = p_n \times 2\pi r \cdot dr$$

Integrating the expression within the limits from 0 to  $R$  for the total frictional torque on the conical pivot bearing.

$$T = \int_0^R 2\pi \mu \cdot p_n \operatorname{cosec} \alpha \cdot r^2 \cdot dr = 2\pi \mu \cdot p_n \cdot \operatorname{cosec} \alpha \left[ \frac{r^3}{3} \right]_0^R$$

$$= 2\pi \mu \cdot p_n \cdot \operatorname{cosec} \alpha \times \frac{R^3}{3} = \frac{2\pi R^3}{3} \times \mu \cdot p_n \cdot \operatorname{cosec} \alpha \quad \dots(i)$$

**Total frictional torque:**

$$T = \int_0^R 2\pi \mu \cdot p_n \operatorname{cosec} \alpha \cdot r^2 \cdot dr = 2\pi \mu \cdot p_n \cdot \operatorname{cosec} \alpha \left[ \frac{r^3}{3} \right]_0^R$$

$$= 2\pi \mu \cdot p_n \cdot \operatorname{cosec} \alpha \times \frac{R^3}{3} = \frac{2\pi R^3}{3} \times \mu \cdot p_n \cdot \operatorname{cosec} \alpha \quad \dots(i)$$

Substituting the value of  $p_n$  in equation (i),

$$T = \frac{2\pi R^3}{3} \times \pi \times \frac{W}{\pi R^2} \times \operatorname{cosec} \alpha = \frac{2}{3} \times \mu \cdot W \cdot R \cdot \operatorname{cosec} \alpha$$

**Considering uniform wear**

In Fig. let  $p_r$  be the normal intensity of pressure at a distance  $r$  from the central axis. We know that, in case of uniform wear, the intensity of pressure varies inversely with the distance.

$$p_r \cdot r = C \text{ (a constant) or } p_r = C/r$$

$$\delta W = p_r \times 2\pi r \cdot dr = \frac{C}{r} \times 2\pi r \cdot dr = 2\pi C \cdot dr$$

The load transmitted to the ring,

Total load transmitted to the bearing,

$$W = \int_0^R 2\pi C \cdot dr = 2\pi C [r]_0^R = 2\pi C \cdot R \text{ or } C = \frac{W}{2\pi R}$$

We know that frictional torque acting on the ring,

$$T_r = 2\pi \mu \cdot p_r \cdot \operatorname{cosec} \alpha \cdot r^2 \cdot dr = 2\pi \mu \times \frac{C}{r} \times \operatorname{cosec} \alpha \cdot r^2 \cdot dr$$

$$= 2\pi \mu \cdot C \cdot \operatorname{cosec} \alpha \cdot r \cdot dr$$

Total frictional torque acting on the bearing,

$$T = \pi\mu \times \frac{W}{2\pi R} \times \operatorname{cosec} \alpha \cdot R^2 = \frac{1}{2} \times \mu \cdot W \cdot R \operatorname{cosec} \alpha = \frac{1}{2} \times \mu \cdot W \cdot l$$

Substituting the value of C, we have

Trapezoidal or Truncated Conical Pivot Bearing

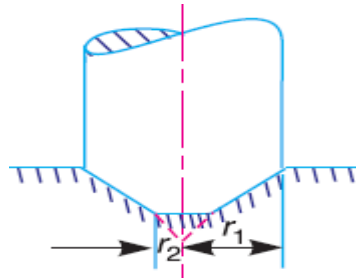

Area of the bearing surface,

$$A = \pi[(r_1)^2 - (r_2)^2]$$

∴ Intensity of uniform pressure,

$$p_n = \frac{W}{A} = \frac{W}{\pi[(r_1)^2 - (r_2)^2]} \quad \dots(i)$$

If the pivot bearing is not conical, but a frustum of a cone with  $r_1$  and  $r_2$ , the external and internal radius respectively as shown in Fig, then

**Considering uniform pressure**

The total torque acting on the bearing is obtained by integrating the value of  $T_r$ , within the limits  $r_1$  and  $r_2$ .

$$T = \int_{r_2}^{r_1} 2\pi\mu \cdot p_n \operatorname{cosec} \alpha \cdot r^2 \cdot dr = 2\pi\mu \cdot p_n \cdot \operatorname{cosec} \alpha \left[ \frac{r^3}{3} \right]_{r_2}^{r_1}$$

$$= 2\pi\mu \cdot p_n \cdot \operatorname{cosec} \alpha \left[ \frac{(r_1)^3 - (r_2)^3}{3} \right]$$

Total torque acting on the bearing,

$$W = \int_{r_2}^{r_1} 2\pi C \cdot dr = 2\pi C [r]_{r_2}^{r_1} = 2\pi C (r_1 - r_2)$$

$$C = \frac{W}{2\pi (r_1 - r_2)}$$



$$T = 2\pi\mu \times \frac{W}{\pi[(r_1)^2 - (r_2)^2]} \times \operatorname{cosec} \alpha \left[ \frac{(r_1)^3 - (r_2)^3}{3} \right]$$

$$= \frac{2}{3} \times \mu.W.\operatorname{cosec} \alpha \left[ \frac{(r_1)^3 - (r_2)^3}{(r_1)^2 - (r_2)^2} \right]$$

Substituting the value of  $p_n$  from equation (i),

Considering uniform wear the load transmitted to the ring,  $\delta W = 2\pi C.dr$

Total load transmitted to the ring,

We know that the torque acting on the ring, considering uniform wear, is Total torque acting on the bearing,

$$T = \int_{r_2}^{r_1} 2\pi \mu.C \operatorname{cosec} \alpha.r.dr = 2\pi \mu.C.\operatorname{cosec} \alpha \left[ \frac{r^2}{2} \right]_{r_2}^{r_1}$$

$$= \pi \mu.C.\operatorname{cosec} \alpha [(r_1)^2 - (r_2)^2]$$

Substituting the value of  $C$  from equation (ii), we get

$$T = \pi\mu \times \frac{W}{2\pi(r_1 - r_2)} \times \operatorname{cosec} \alpha [(r_1)^2 - (r_2)^2]$$

$$= \frac{1}{2} \times \mu.W (r_1 + r_2) \operatorname{cosec} \alpha = \mu.W.R \operatorname{cosec} \alpha$$

$$R = \text{Mean radius of the bearing} = \frac{r_1 + r_2}{2}$$

## PROBLEMS

**Example 1.** A conical pivot supports a load of 20 kN, the cone angle is  $120^\circ$  and the intensity of normal pressure is not to exceed  $0.3 \text{ N/mm}^2$ . The external diameter is twice the internal diameter. Find the outer and inner radii of the bearing surface. If the shaft rotates at 200 r.p.m. and the coefficient of friction is 0.1, find the power absorbed in friction. Assume uniform pressure.

**Solution:** Given:  $W = 20 \text{ kN} = 20 \times 10^3 \text{ N}$ ;  $2\alpha = 120^\circ$  or  $\alpha = 60^\circ$ ;  $p_n = 0.3 \text{ N/mm}^2$ ;  $N = 200 \text{ r.p.m.}$  or  $\omega = 2\pi \times 200/60 = 20.95 \text{ rad/s}$ ;  $\mu = 0.1$

Outer and inner radii of the bearing surface.



Let  $r_1$  and  $r_2$  = Outer and inner radii of the bearing surface, in mm. Since the external diameter is twice the internal diameter, therefore

$$r_1 = 2 r_2$$

$$0.3 = \frac{W}{\pi[(r_1)^2 - (r_2)^2]} = \frac{20 \times 10^3}{\pi[(2r_2)^2 - (r_2)^2]} = \frac{2.12 \times 10^3}{(r_2)^2}$$

$$(r_2)^2 = 2.12 \times 10^3 / 0.3 = 7.07 \times 10^3 \text{ or } r_2 = 84 \text{ mm Ans.}$$

$$r_1 = 2 r_2 = 2 \times 84 = 168 \text{ mm Ans.}$$

We know that intensity of normal pressure ( $p_n$ ),

Power absorbed in friction

$$T = \frac{2}{3} \times \mu.W.\text{cosec } \alpha \left[ \frac{(r_1)^3 - (r_2)^3}{(r_1)^2 - (r_2)^2} \right]$$

$$= \frac{2}{3} \times 0.1 \times 20 \times 10^3 \times \text{cosec } 60^\circ = \left[ \frac{(168)^3 - (84)^3}{(168)^2 - (84)^2} \right] \text{ N-mm}$$

$$= 301760 \text{ N-mm} = 301.76 \text{ N-m}$$

We know that total frictional torque (assuming uniform pressure),

Power absorbed in friction

$$P = T.\omega = 301.76 \times 20.95 = 6322 \text{ W} = 6.322 \text{ kW}$$

## Flat Collar Bearing

We have already discussed that collar bearings are used to take the axial thrust of the rotating shafts. There may be a single collar or multiple collar bearings as shown in Fig.(a) and (b) respectively. The collar bearings are also known as **thrust bearings**. The friction in the collar bearings may be found as discussed below:

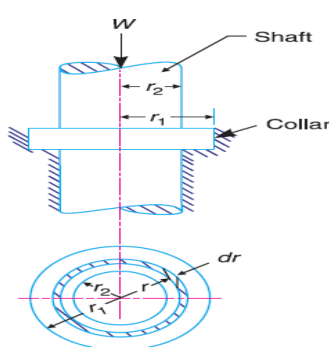

(a) Single collar bearing

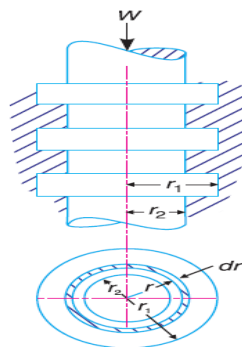

(b) Multiple collar bearing.

Consider a single flat collar bearing supporting a shaft as shown in Fig(a).



Let  $r_1$  = External radius of the collar,

$r_2$  = Internal radius of the collar.

Area of the bearing surface,

$$A = \pi [(r_1)^2 - (r_2)^2]$$

Considering uniform pressure

When the pressure is uniformly distributed over the bearing surface, then the intensity of pressure,

$$p = \frac{W}{A} = \frac{W}{\pi[(r_1)^2 - (r_2)^2]} \quad \dots(i)$$

The frictional torque on the ring of radius  $r$  and thickness  $dr$ ,

$$T_r = 2\pi\mu.p.r^2.dr$$

Integrating this equation within the limits from  $r_2$  to  $r_1$  for the total frictional torque on the collar.

Total frictional torque,

$$T = \int_{r_2}^{r_1} 2\pi\mu.p.r^2.dr = 2\pi\mu.p \left[ \frac{r^3}{3} \right]_{r_2}^{r_1} = 2\pi\mu.p \left[ \frac{(r_1)^3 - (r_2)^3}{3} \right]$$

$$\begin{aligned} T &= 2\pi\mu \times \frac{W}{\pi[(r_1)^2 - (r_2)^2]} \left[ \frac{(r_1)^3 - (r_2)^3}{3} \right] \\ &= \frac{2}{3} \times \mu.W \left[ \frac{(r_1)^3 - (r_2)^3}{(r_1)^2 - (r_2)^2} \right] \end{aligned}$$

Substituting the value of  $p$  from equation (i),

Considering uniform wear

The load transmitted on the ring, considering uniform wear is,

$$\begin{aligned} \delta W &= p_r . 2\pi r . dr = \frac{C}{r} \times 2\pi r . dr = 2\pi C . dr \\ W &= \int_{r_2}^{r_1} 2\pi C . dr = 2\pi C [r]_{r_2}^{r_1} = 2\pi C (r_1 - r_2) \end{aligned}$$

$$C = \frac{W}{2\pi(r_1 - r_2)} \quad \dots(ii)$$



Total load transmitted to the collar,

We also know that frictional torque on the ring; we also know that frictional torque on the ring,

$$T_r = \mu \cdot \delta W \cdot r = \mu \times 2\pi C \cdot dr \cdot r = 2\pi\mu \cdot C \cdot r \cdot dr$$

Total frictional torque on the bearing,

$$T = \int_{r_2}^{r_1} 2\pi\mu C \cdot r \cdot dr = 2\pi\mu C \left[ \frac{r^2}{2} \right]_{r_2}^{r_1} = 2\pi\mu C \left[ \frac{(r_1)^2 - (r_2)^2}{2} \right]$$
$$= \pi\mu C [(r_1)^2 - (r_2)^2]$$

Substituting the value of C from equation (ii),

$$T = \pi\mu \times \frac{W}{2\pi(r_1 - r_2)} [(r_1)^2 - (r_2)^2] = \frac{1}{2} \times \mu \cdot W (r_1 + r_2)$$

## PROBLEMS

**Example 1.** A thrust shaft of a ship has 6 collars of 600 mm external diameter and 300 mm internal diameter. The total thrust from the propeller is 100 kN. If the coefficient of friction is 0.12 and speed of the engine 90 r.p.m., find the power absorbed in friction at the thrust block, assuming.

1. Uniform pressure
2. Uniform wear.

**Solution.** Given:  $n = 6$ ;  $d_1 = 600$  mm or  $r_1 = 300$  mm;  $d_2 = 300$  mm or  $r_2 = 150$  mm;

$$W = 100 \text{ kN} = 100 \times 10^3 \text{ N};$$

$$\mu = 0.12; N = 90 \text{ r.p.m. or } \omega = 2\pi \times 90/60 = 9.426 \text{ rad/s}$$

Power absorbed in friction, assuming uniform pressure

We know that total frictional torque transmitted,

Power absorbed in friction,

$$P = T\omega = 2800 \times 9.426 = 26400 \text{ W} = 26.4 \text{ kW}$$

Power absorbed in friction assuming uniform wear

We know that total frictional torque transmitted,

$$T = \frac{1}{2} \times \mu \cdot W (r_1 + r_2) = \frac{1}{2} \times 0.12 \times 100 \times 10^3 (300 + 150) \text{ N-mm}$$
$$= 2700 \times 10^3 \text{ N-mm} = 2700 \text{ N-m}$$

Power absorbed in friction,

$$P = T \cdot \omega = 2700 \times 9.426 = 25450 \text{ W} = 25.45 \text{ kW}$$



**Example 2.** A shaft has a number of collars integral with it. The external diameter of the collars is 400 mm and the shaft diameter is 250 mm. If the intensity of pressure is 0.35 N/mm<sup>2</sup>(uniform) and the coefficient of friction is 0.05, estimate power absorbed when the shaft runs at 105 r.p.m. carrying a load of 150 kN. Number of collars required.

**Solution.** Given:  $d_1 = 400$  mm or  $r_1 = 200$  mm ;  $d_2 = 250$  mm or  $r_2 = 125$  mm ;  $p = 0.35$  N/mm<sup>2</sup> ;  $\mu = 0.05$  ;  $N = 105$  r.p.m or

$$\omega = 2\pi \times 105/60 = 11 \text{ rad/s} ; W = 150 \text{ kN} = 150 \times 10^3 \text{ N}$$

**Power absorbed**

We know that for uniform pressure, total frictional torque transmitted

$$T = \frac{2}{3} \times \mu \cdot W \left[ \frac{(r_1)^3 - (r_2)^3}{(r_1)^2 - (r_2)^2} \right] = \frac{2}{3} \times 0.05 \times 150 \times 10^3 \left[ \frac{(200)^3 - (125)^3}{(200)^2 - (125)^2} \right] \text{ N-mm}$$

$$= 5000 \times 248 = 1240 \times 10^3 \text{ N-mm} = 1240 \text{ N-m}$$

Power absorbed,

$$P = T\omega = 1240 \times 11 = 13640 \text{ W} = 13.64 \text{ kW}$$

Number of collars required

Let  $n$  = Number of collars required.

We know that the intensity of uniform pressure ( $p$ ),



## INDUSTRIAL APPLICATIONS

1. Human body modeled as a system of rigid bodies of geometrical solids. Representative bones were added for better visualization of the walking person.

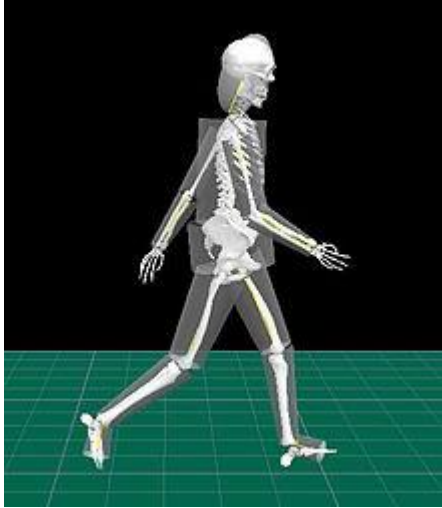

2. Screw jack



In a **bottle jack** the piston is vertical and directly supports a bearing pad that contacts the object being lifted. With a single action piston the lift is somewhat less than twice the collapsed height of the jack, making it suitable only for vehicles with a relatively high clearance. For lifting structures such as houses the hydraulic interconnection of multiple vertical jacks through valves enables the even distribution of forces while enabling close control of the lift.

In a **floor jack** a horizontal piston pushes on the short end of a bellcrank, with the long arm providing the vertical motion to a lifting pad, kept horizontal with a horizontal linkage. Floor jacks usually include castors and wheels, allowing compensation for the arc taken by the lifting pad. This mechanism provides a low profile when collapsed, for easy maneuvering underneath the vehicle, while allowing considerable extension.



## TUTORIAL QUESTIONS

1. Discuss briefly the various types of friction experienced by a body
2. Derive from first principles an expression for the effort required to raise a load with a screw jack taking friction into consideration.
3. What is meant by the expression 'friction circle'? Deduce an expression for the radius of friction circle in terms of the radius of the journal and the angle of friction.
4. Derive from first principles an expression for the friction moment of a conical pivot assuming (i) Uniform pressure, and (ii) Uniform wear.
5. Find the force required to move a load of 300 N up a rough plane, the force being applied parallel to the plane. The inclination of the plane is such that a force of 60 N inclined at  $30^\circ$  to a similar smooth plane would keep the same load in equilibrium. The coefficient of friction is 0.3.
6. A square threaded screw of mean diameter 25 mm and pitch of thread 6 mm is utilised to lift a weight of 10 kN by a horizontal force applied at the circumference of the screw. Find the magnitude of the
7. Force if the coefficient of friction between the nut and screw is 0.02.
8. A bolt with a square threaded screw has mean diameter of 25 mm and a pitch of 3 mm. It carries an axial thrust of 10 kN on the bolt head of 25 mm mean radius. If  $\mu = 0.12$ , find the force required at the end of a spanner 450 mm long, in tightening up the bolt.



## ASSIGNMENT QUESTIONS

1. The thrust of a propeller shaft in a marine engine is taken up by a number of collars integral with the shaft which is 300 mm in diameter. The thrust on the shaft is 200 kN and the speed is 75 r.p.m. Taking  $\mu$  constant and equal to 0.05 and assuming intensity of pressure as uniform and equal to 0.3 N/mm<sup>2</sup>, find the external diameter of the collars and the number of collars required, if the power lost in friction is not to exceed 16 kW.
2. A shaft has a number of a collars integral with it. The external diameter of the collars is 400 mm and the shaft diameter is 250 mm. If the intensity of pressure is 0.35 N/mm<sup>2</sup> (uniform) and the coefficient of friction is 0.05, estimate: 1. power absorbed when the shaft runs at 105 r.p.m. carrying a load of 150 kN and 2. number of collars required.
3. A thrust shaft of a ship has 6 collars of 600 mm external diameter and 300 mm internal diameter. The total thrust from the propeller is 100 kN. If the coefficient of friction is 0.12 and speed of the engine 90 r.p.m., find the power absorbed in friction at the thrust block, assuming 1. uniform pressure and 2. Uniform wear.
4. A conical pivot bearing supports a vertical shaft of 200 mm diameter. It is subjected to a load of 30 kN. The angle of the cone is 120° and the coefficient of friction is 0.025. Find the power lost in friction when the speed is 140 r.p.m., assuming 1. uniform pressure ; and 2. uniform wear.
5. A conical pivot supports a load of 20 kN, the cone angle is 120° and the intensity of normal pressure is not to exceed 0.3 N/mm<sup>2</sup>. The external diameter is twice the internal diameter. Find the outer and inner radii of the bearing surface. If the shaft rotates at 200 r.p.m. and the coefficient of friction is 0.1, find the power absorbed in friction. Assume uniform pressure.
6. A vertical shaft 150 mm in diameter rotating at 100 r.p.m. rests on a flat end footstep bearing. The shaft carries a vertical load of 20 kN. Assuming uniform pressure distribution and coefficient of friction equal to 0.05, estimate power lost in friction.
7. Derive the Resultant Effect of a System of Forces Acting on a Rigid Body ?
8. Explain the D'Alembert's Principle?
9. Explain Velocity and Acceleration of the Reciprocating Parts in Engines?
10. The crank and connecting rod of a reciprocating engine are 200 mm and 700 mm respectively. The crank is rotating in clockwise direction at 120 rad/s. Find with the help of Klein's construction: 1. Velocity and acceleration of the piston, 2. Velocity and acceleration of the midpoint of the connecting rod, and 3. Angular velocity and angular acceleration of the connecting rod, at the instant when the crank is at 30° to I.D.C. (inner dead centre).





---

## UNIT 3

# CLUTCHES, BRAKE/DYNAMOMETERS/ TURNING MOMENT DIAGRAM & FLY WHEEL

---



## **Course Objectives**

Able to learn about the working of Clutches, Brakes, Dynamometers and Fly wheel.

## **Course Outcomes**

The student will learn about the kinematics and dynamic analysis of machine elements.



## FRICTION CLUTCHES

A clutch is a device used to transmit the rotary motion of one shaft to another when desired. The axes of the two shafts are coincident. In friction clutches, the connection of the engine shaft to the gear box shaft is affected by friction between two or more rotating concentric surfaces. The surfaces can be pressed firmly against one another when engaged and the clutch tends to rotate as a single unit.

### SINGLE PLATE CLUTCH (DISC CLUTCH)

A disc clutch consists of a clutch plate attached to a splined hub which is free to slide axially on splines cut on the driven shaft. The clutch plate is made of steel and has a ring of friction lining on each side. The engine shaft supports a rigidly fixed flywheel. A spring-loaded pressure plate presses the clutch plate firmly against the flywheel when the clutch is engaged. When disengaged, the springs press against a cover attached to the flywheel. Thus, both the flywheel and the pressure plate rotate with the input shaft. The movement of the clutch pedal is transferred to the pressure plate through a thrust bearing. Figure 8.13 shows the pressure plate pulled back by the release levers and the friction linings on the clutch plate are no longer in contact with the pressure plate or the flywheel. The flywheel rotates without driving the clutch plate and thus, the driven shaft.

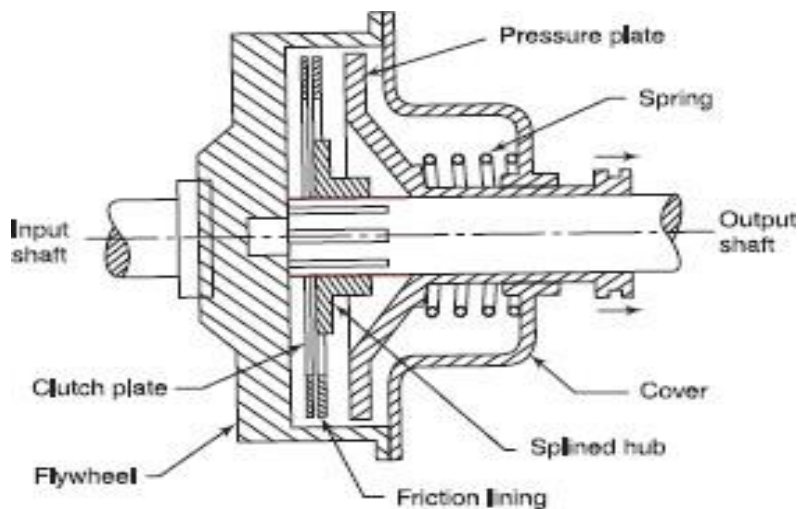

When the foot is taken off the clutch pedal, the pressure on the thrust bearing is released. As a result, the springs become free to move the pressure plate to bring it in contact with the clutch plate. The clutch plate slides on the splined hub and is tightly gripped between the pressure plate and the fly wheel. The friction between the linings on the clutch plate, and the flywheel on one side and the pressure plate on the other, cause the clutch plate and hence, the driven shaft to rotate. In case the resisting torque on the drive shaft exceeds the torque at the clutch, clutch slip will occur.



## Torque transmitted by plate or disc clutch

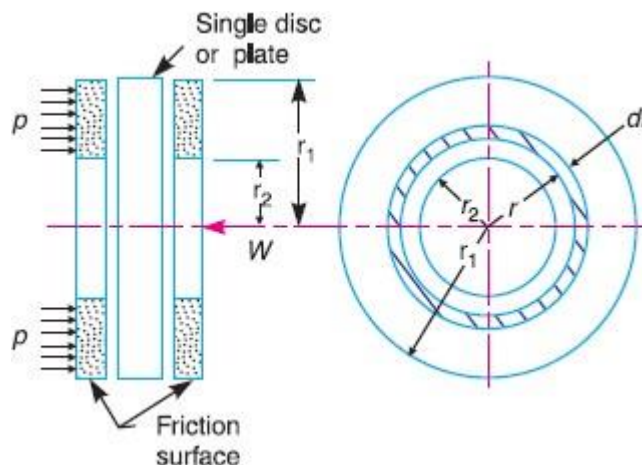

The following notations are used in the derivation  $T$  = Torque transmitted by the clutch

$P$  = intensity of axial pressure

$r_1$  &  $r_2$  = external and internal radii of friction faces

$\mu$  = co-efficient of friction

Consider an elemental ring of radius  $r$  and thickness  $dr$  Friction surface =  $2\pi r dr$

Axial force on the  $dw$  = pressure \* area

$$= P * 2\pi r dr$$

Frictional force acting on the ring tangentially at radius  $r$   $F_r = \mu dw = \mu * p * 2\pi r dr$

Frictional torque acting on the ring  $T_r = F_r * r = \mu p * 2\pi r * dr * r = 2\pi \mu p r^2 dr$

Considering uniform pressure

When the pressure is uniformly distributed over the entire area of the friction face, then the intensity of pressure,

$$P = W / \pi [(r_1^2 - r_2^2)] \quad (i)$$

Where  $W$  = Axial thrust with which the contact or friction surfaces are held together.

We have discussed above that the frictional torque on the elementary ring of radius  $r$  and thickness  $dr$  is

$$T_r = 2 \pi \mu . p . r^2 dr$$

Integrating this equation within the limits from  $r_2$  to  $r_1$  for the total frictional torque.

Therefore total frictional torque acting on the friction surface or on the clutch,

$$T = \int_{r_2}^{r_1} 2 \pi \mu . p . r^2 . dr = 2 \pi \mu p \left[ \frac{r^3}{3} \right]_{r_2}^{r_1} = 2 \pi \mu p \left[ \frac{(r_1)^3 - (r_2)^3}{3} \right]$$



Substituting the value of  $p$  from equation (i),

$$T = 2\pi\mu \times \frac{W}{\pi[(r_1)^2 - (r_2)^2]} \times \frac{(r_1)^3 - (r_2)^3}{3}$$

$$= \frac{2}{3} \times \mu.W \left[ \frac{(r_1)^3 - (r_2)^3}{(r_1)^2 - (r_2)^2} \right] = \mu.W.R$$

$R$  = Mean radius of friction surface

$$= \frac{2}{3} \left[ \frac{(r_1)^3 - (r_2)^3}{(r_1)^2 - (r_2)^2} \right]$$

## 2. Considering uniform wear

Let  $p$  be the normal intensity of pressure at a distance  $r$  from the axis of the Clutch. Since the intensity of pressure varies inversely with the distance, therefore

$$p.r = C \text{ (a constant) or } p = C/r$$

and the normal force on the ring,

$$\delta W = p.2\pi r.dr = \frac{C}{r} \times 2\pi C.dr = 2\pi C.dr$$

$\therefore$  Total force acting on the friction surface,

$$W = \int_{r_2}^{r_1} 2\pi C dr = 2\pi C [r]_{r_2}^{r_1} = 2\pi C (r_1 - r_2)$$

$$C = \frac{W}{2\pi(r_1 - r_2)}$$

We know that the frictional torque acting on the ring,

$$T_r = 2\pi\mu.p r^2.dr = 2\pi\mu \times \frac{C}{r} \times r^2.dr = 2\pi\mu.C.r.dr$$

Total frictional torque on the friction surface,

$$\begin{aligned} T &= \int_{r_2}^{r_1} 2\pi\mu.C.r.dr = 2\pi\mu.C \left[ \frac{r^2}{2} \right]_{r_2}^{r_1} = 2\pi\mu.C \left[ \frac{(r_1)^2 - (r_2)^2}{2} \right] \\ &= \pi\mu.C [(r_1)^2 - (r_2)^2] = \pi\mu \times \frac{W}{2\pi(r_1 - r_2)} [(r_1)^2 - (r_2)^2] \\ &= \frac{1}{2} \times \mu.W (r_1 + r_2) = \mu.W.R \end{aligned}$$

$R$  = Mean radius of the friction surface =  $(r_1 + r_2)/2$

## Multiple plate clutches

In a multi-plate clutch, the number of frictional linings and the metal plates is increased which increases the capacity of the clutch to transmit torque. Figure 8.14 shows a simplified diagram of a multi-plate



clutch. The friction rings are splined on their outer circumference and engage with corresponding splines on the flywheel. They are free to slide axially.

The Friction material thus, rotates with the flywheel and the engine shaft. The Number of friction rings depends

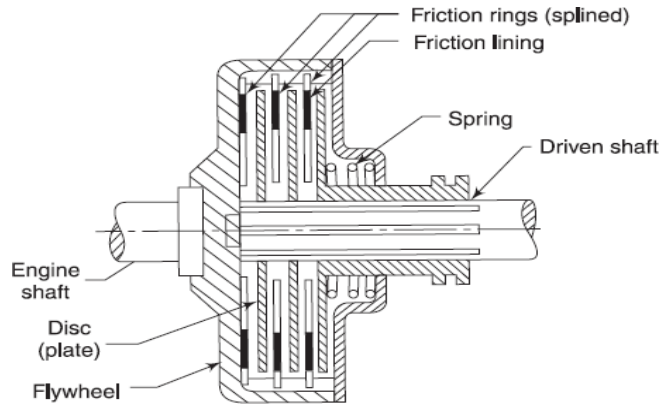

**Fig. 8.14**

The driven shaft also supports discs on the splines which rotate with the driven shaft and can slide axially. If the actuating force on the pedal is removed, a spring presses the discs into contact with the friction rings and the torque is transmitted between the engine shaft and the driven shaft. If  $n$  is the total number of plates both on the driving and the driven members, the number of active surfaces will be  $n - 1$ .

Let  $n_1$  = Number of discs on the driving shaft, and

$n_2$  = Number of discs on the driven shaft.

Number of pairs of contact surfaces,  $n = n_1 + n_2 - 1$

And total frictional torque acting on the friction surfaces or on the clutch,

$$T = n \cdot \mu \cdot W \cdot R$$

Where  $R$  = Mean radius of the friction surfaces

$$R = \frac{2}{3} \left[ \frac{(r_1)^3 - (r_2)^3}{(r_1)^2 - (r_2)^2} \right]$$

$$= \frac{r_1 + r_2}{2}$$

**PROBLEMS**

**Example1.** Determine the maximum, minimum and average pressure in plate clutch when the axial force is 4 kN. The inside radius of the contact surface is 50 mm and the outside radius is 100 mm. Assume uniform wear.



### Solution.

Given:  $W = 4 \text{ kN} = 4 \times 10^3 \text{ N}$ ,  $r_2 = 50 \text{ mm}$ ;  $r_1 = 100 \text{ mm}$

Maximum pressure

Let  $p_{max}$  = Maximum pressure.

Since the intensity of pressure is maximum at the inner radius ( $r_2$ ), therefore

$$p_{max} \times r_2 = C \text{ or } C = 50 p_{max}$$

We know that the total force on the contact surface ( $W$ ),

$$4 \times 10^3 = 2 \pi C (r_1 - r_2) = 2 \pi \times 50 p_{max} (100 - 50) = 15710 p_{max}$$

$$p_{max} = 4 \times 10^3 / 15710 = 0.2546 \text{ N/mm}^2$$

### Minimum pressure

Let  $p_{min}$  = Minimum pressure.

Since the intensity of pressure is minimum at the outer radius ( $r_1$ ), Therefore  $p_{min} \times r_1 = C$  or  $C = 100 p_{min}$

$p_{min}$

We know that the total force on the contact surface ( $W$ ),

$$4 \times 10^3 = 2 \pi C (r_1 - r_2) = 2 \pi \times 100 p_{min} (100 - 50) = 31420 p_{min}$$

$$p_{min} = 4 \times 10^3 / 31420 = 0.1273 \text{ N/mm}^2$$

Average pressure

We know that average pressure,

$$P_{av} = \frac{\text{Total normal force on contact surface}}{\text{Cross-sectional area of contact surfaces}}$$
$$= \frac{W}{\pi[(r_1)^2 - (r_2)^2]} = \frac{4 \times 10^3}{\pi[(100)^2 - (50)^2]} = 0.17 \text{ N/mm}^2$$

**Example2.** A single plate clutch, with both sides effective, has outer and inner diameters 300 mm and 200 mm respectively. The maximum intensity of pressure at any point in the contact surface is not to exceed 0.1 N/mm<sup>2</sup>. If the coefficient of friction is 0.3, determine the power transmitted by a clutch at a speed 2500 r.p.m.

Solution. Given:  $d_1 = 300 \text{ mm}$  or  $r_1 = 150 \text{ mm}$ ;  $d_2 = 200 \text{ mm}$  or  $r_2 = 100 \text{ mm}$ ;

$$p = 0.1 \text{ N/mm}^2; \mu = 0.3; N = 2500 \text{ r.p.m. or } \omega = 2\pi \times 2500 / 60 = 261.8 \text{ rad/s}$$

Since the intensity of pressure ( $p$ ) is maximum at the inner radius ( $r_2$ ), therefore for uniform



$$p \cdot r_2 = C \text{ or } C = 0.1 \times 100 = 10 \text{ N/mm}$$

We know that the axial thrust,

$$W = 2 \pi C (r_1 - r_2) = 2 \pi \times 10 (150 - 100) = 3142 \text{ N}$$

$$R = \frac{r_1 + r_2}{2} = \frac{150 + 100}{2} = 125 \text{ mm} = 0.125 \text{ m}$$

Mean radius of the friction surfaces for uniform wear,

We know that torque transmitted,

$$T = n \cdot \mu \cdot W \cdot R = 2 \times 0.3 \times 3142 \times 0.125 = 235.65 \text{ N-m}$$

Power transmitted by a clutch,

$$P = T \cdot \omega = 235.65 \times 261.8 = 61\,693 \text{ W} = 61.693 \text{ kW}$$

### CONE CLUTCH

A cone clutch, as shown in Fig. 10.24, was extensively used in automobiles but now-a-days it has been replaced completely by the disc clutch

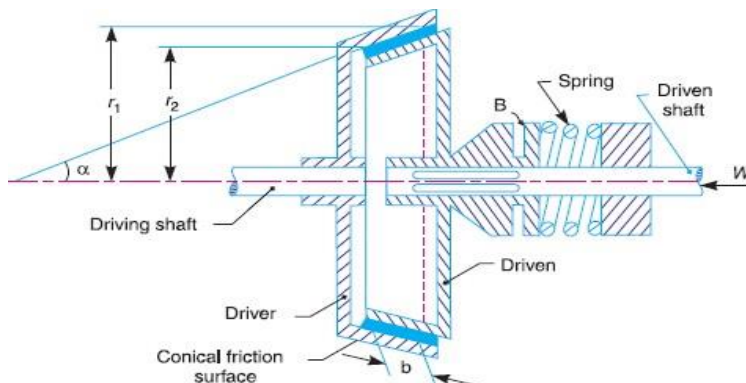

Fig. 10.24. Cone clutch.

It consists of one pair of friction surface only. In a cone clutch, the driver is keyed to the driving shaft by a sunk key and has an inside conical surface or face which exactly fits into the outside conical surface of the driven.

The driven member resting on the feather key in the driven shaft, maybe shifted along the shaft by a forked lever provided at B, in order to engage the clutch by bringing the two conical surfaces in contact. Due to the frictional resistance set up at this contact surface, the torque is transmitted from one shaft to another. In some cases, a spring is placed around the driven shaft in contact with the hub of the driven. This spring holds the clutch faces in contact and maintains the pressure between them, and the forked lever is used only for disengagement of the clutch. The contact surfaces of the clutch may be metal to metal contact, but more often the driven member is lined with some material like wood, leather, cork or asbestos etc. The material of the clutch faces (*i.e.* contact surfaces) depends upon the allowable normal pressure and the coefficient of friction.



Consider a pair of friction surface as shown in Fig. Since the area of contact of a pair of friction surface is a frustum of a cone, therefore the torque transmitted by the cone clutch maybe determined in the similar manner as discussed.

Let  $p_n$  = Intensity of pressure with which the conical friction surfaces are held together (*i.e.* normal pressure between contact surfaces),

$r_1$  and  $r_2$  = Outer and inner radius of friction surfaces respectively

$R$  = Mean radius of the friction surface =  $(r_1 + r_2)/2$

$\alpha$  = Semi angle of the cone (also called face angle of the cone) or the angle of the friction surface with the axis of the clutch,

$\mu$  = Coefficient of friction between contact surfaces, and

$b$  = Width of the contact surfaces (also known as face width or clutch face).

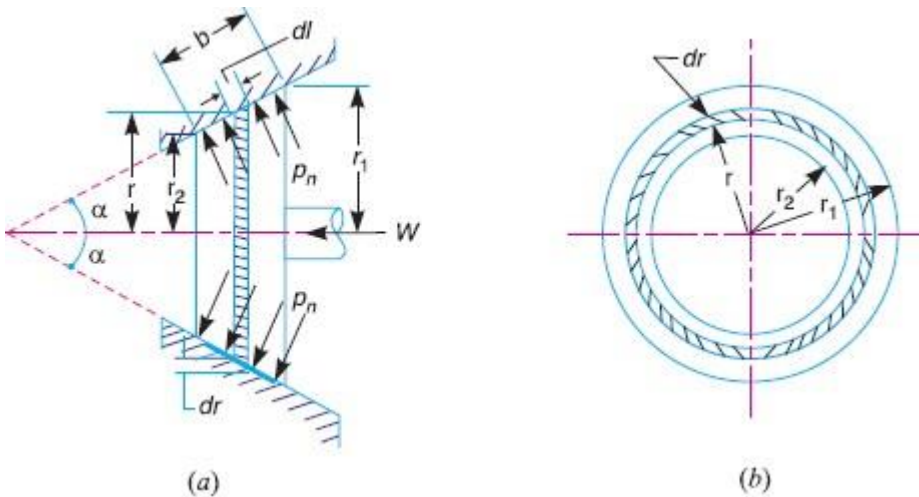

Consider a small ring of radius  $r$  and thickness  $dr$ , as shown in Fig. 10.25 (b).

Let  $dl$  is length of ring of the friction surface, such that

$$dl = dr \cdot \csc \alpha \quad \text{Area of the ring} = A = 2\pi r \cdot dl = 2\pi r \cdot dr \cdot \csc \alpha$$

We shall consider the following two cases :

### When there is a uniform pressure and when there is a uniform wear.

#### Considering uniform pressure

We know that normal load acting on the ring,

$$\delta W_n = \text{Normal pressure} \times \text{Area of ring} = p_n \times 2\pi r \cdot dr \cdot \csc \alpha$$

$\delta W$  = Horizontal component of  $\delta W_n$  (*i.e.* in the direction of  $W$ )

$$= \delta W_n \times \sin \alpha = p_n \times 2\pi r \cdot dr \cdot \csc \alpha \times \sin \alpha = 2\pi \times p_n \cdot r \cdot dr$$



Total axial load transmitted to the clutch or the axial spring force required,

$$W = \int_{r_2}^{r_1} 2\pi p_n r \cdot dr = 2\pi p_n \left[ \frac{r^2}{2} \right]_{r_2}^{r_1} = 2\pi p_n \left[ \frac{(r_1)^2 - (r_2)^2}{2} \right]$$

$$= \pi p_n [(r_1)^2 - (r_2)^2]$$

$$p_n = \frac{W}{\pi[(r_1)^2 - (r_2)^2]}$$

We know that frictional force on the ring acting tangentially at radius  $r$ ,  $F_r = \mu \cdot \delta W_n = \mu \cdot p_n \times 2\pi r \cdot dr \cdot \text{cosec } \alpha$

$\propto$  Frictional torque acting on the ring,

Integrating this expression within the limits from  $r_2$  to  $r_1$  for the total frictional torque on the clutch

$\therefore$  Total frictional torque,

$$T = \int_{r_2}^{r_1} 2\pi \mu p_n \cdot \text{cosec } \alpha r^2 \cdot dr = 2\pi \mu p_n \cdot \text{cosec } \alpha \left[ \frac{r^3}{3} \right]_{r_2}^{r_1}$$

$$= 2\pi \mu p_n \cdot \text{cosec } \alpha \left[ \frac{(r_1)^3 - (r_2)^3}{3} \right]$$

Substituting the value of  $p_n$  from equation (i), we get

$$T = 2\pi \mu \times \frac{W}{\pi[(r_1)^2 - (r_2)^2]} \times \text{cosec } \alpha \left[ \frac{(r_1)^3 - (r_2)^3}{3} \right]$$

$$= \frac{2}{3} \times \mu \cdot W \cdot \text{cosec } \alpha \left[ \frac{(r_1)^3 - (r_2)^3}{(r_1)^2 - (r_2)^2} \right]$$

### Considering uniform wear

In Fig., let  $p_r$  be the normal intensity of pressure at a distance  $r$  from the axis of the clutch. We know that, in case of uniform wear, the intensity of pressure varies inversely with the distance.

$$p_r \cdot r = C \text{ (a constant) or } p_r = C/r$$

We know that the normal load acting on the ring,

$\delta W_n = \text{Normal pressure} \times \text{Area of ring} = p_r \times 2\pi r \cdot dr \cdot \text{cosec } \alpha$  The axial load acting on the ring ,

$$\delta W = \delta W_n \times \sin \alpha = p_r \cdot 2\pi r \cdot dr \cdot \text{cosec } \alpha \cdot \sin \alpha = p_r \times 2\pi r \cdot dr$$

$$= \frac{C}{r} \times 2\pi r \cdot dr = 2\pi C \cdot dr$$

$\therefore$  Total axial load transmitted to the clutch,

$$W = \int_{r_2}^{r_1} 2\pi C \cdot dr = 2\pi C [r]_{r_2}^{r_1} = 2\pi C (r_1 - r_2)$$

$$C = \frac{W}{2\pi(r_1 - r_2)}$$

We know that frictional force acting on the ring,



$F_r = \mu \cdot \delta W_n = \mu \cdot p_r \times 2\pi r \times dr \operatorname{cosec} \alpha$  Frictional torque acting on the ring,

$$= \mu \times \frac{C}{r} \times 2\pi r^2 \cdot dr \operatorname{cosec} \alpha = 2\pi\mu \cdot C \operatorname{cosec} \alpha \times r \, dr$$

$\therefore$  Total frictional torque acting on the clutch,

$$T = \int_{r_2}^{r_1} 2\pi\mu \cdot C \operatorname{cosec} \alpha \cdot r \, dr = 2\pi\mu \cdot C \operatorname{cosec} \alpha \left[ \frac{r^2}{2} \right]_{r_2}^{r_1}$$

$$= 2\pi\mu \cdot C \operatorname{cosec} \alpha \left[ \frac{(r_1)^2 - (r_2)^2}{2} \right]$$

Substituting the value of  $C$  from equation (i), we have

$$T = 2\pi\mu \times \frac{W}{2\pi(r_1 - r_2)} \times \operatorname{cosec} \alpha \left[ \frac{(r_1)^2 - (r_2)^2}{2} \right]$$

$$= \mu \cdot W \operatorname{cosec} \alpha \left( \frac{r_1 + r_2}{2} \right) = \mu \cdot W \cdot R \operatorname{cosec} \alpha$$

$$R = \frac{r_1 + r_2}{2} = \text{Mean radius of friction surface}$$

## PROBLEMS

Example 1. An engine developing 45 kW at 1000 r.p.m. is fitted with a cone clutch built inside the flywheel. The cone has a face angle of  $12.5^\circ$  and a maximum mean diameter of 500 mm. The coefficient of friction is 0.2. The normal pressure on the clutch face is not to exceed 0.1 N/mm<sup>2</sup>. Determine: 1. the axial spring force necessary to engage to clutch, and 2. the face width required.

Solution. Given :  $P = 45 \text{ kW} = 45 \times 10^3 \text{ W}$  ;  $N = 1000 \text{ r.p.m.}$  or  $\omega = 2\pi \times 1000/60 = 104.7 \text{ rad/s}$  ;  $\alpha = 12.5^\circ$  ;  $D = 500 \text{ mm}$  or  $R = 250 \text{ mm} = 0.25 \text{ m}$  ;  $\mu = 0.2$  ;

$$p_n = 0.1 \text{ N/mm}^2$$

Axial spring force necessary to engage the clutch

First of all, let us find the torque ( $T$ ) developed by the clutch and the normal load ( $W_n$ ) acting on the friction surface.

We know that power developed by the clutch ( $P$ ),

$$45 \times 10^3 = T\omega = T \times 104.7 \text{ or } T = 45 \times 10^3 / 104.7 = 430 \text{ N-m}$$

We also know that the torque developed by the clutch ( $T$ ),  $430 = \mu \cdot W_n \cdot R = 0.2 \times W_n \times 0.25 = 0.05 W_n$

$$W_n = 430 / 0.05 = 8600 \text{ N}$$

Axial spring force necessary to engage the clutch,

$$W_e = W_n (\sin \alpha + \mu \cos \alpha)$$

$$= 8600 (\sin 12.5^\circ + 0.2 \cos 12.5^\circ) = 3540 \text{ N}$$

Face width required



Let  $b$  = Face width required

We know that normal load acting on the friction surface ( $W_n$ ),  $8600 = p_n \times 2\pi R.b = 0.1 \times 2\pi \times 250 \times b = 157 b$

$$b = 8600/157 = 54.7 \text{ mm}$$

**Example 2.** A conical friction clutch is used to transmit 90 kW at 1500 r.p.m. The semi cone angle is  $20^\circ$  and the coefficient of friction is 0.2. If the mean diameter of the bearing surface is 375 mm and the intensity of normal pressure is not to exceed 0.25 N/mm<sup>2</sup>, find the dimensions of the conical bearing surface and the axial load required.

Solution. Given:  $P = 90 \text{ kW} = 90 \times 10^3 \text{ W}$ ;  $N = 1500 \text{ r.p.m.}$  or  $\omega = 2\pi \times 1500/60 = 156 \text{ rad/s}$ ;  $\alpha = 20^\circ$ ;  $\mu = 0.2$ ;  $D = 375 \text{ mm}$  or  $R = 187.5 \text{ mm}$ ;  $p_n = 0.25 \text{ N/mm}^2$

Dimensions of the conical bearing surface

Let  $r_1$  and  $r_2$  = External and internal radii of the bearing surface respectively,

$b$  = Width of the bearing surface in mm, and

$T$  = Torque transmitted.

We know that power transmitted ( $P$ ),  $90 \times 10^3 = T\omega = T \times 156$

$$T = 90 \times 10^3/156 = 577 \text{ N-m} = 577 \times 10^3 \text{ N-mm}$$

The torque transmitted ( $T$ ),

$$577 \times 10^3 = 2\pi \mu p_n R^2 . b = 2\pi \times 0.2 \times 0.25 (187.5)^2 b = 11\,046 b$$

$$b = 577 \times 10^3/11\,046 = 52.2 \text{ mm}$$

We know that  $r_1 + r_2 = 2R = 2 \times 187.5 = 375 \text{ mm}$ ..... i

$r_1 - r_2 = b \sin \alpha = 52.2 \sin 20^\circ = 18 \text{ mm}$ ..... ii

From equations (i) and (ii),

$$r_1 = 196.5 \text{ mm, and } r_2 = 178.5 \text{ mm}$$

Axial load required

Since in case of friction clutch, uniform wear is considered and the intensity of pressure is maximum at the minimum contact surface radius ( $r_2$ ), therefore

$$p_n . r_2 = C \text{ (a constant) or } C = 0.25 \times 178.5 = 44.6 \text{ N/mm}$$

We know that the axial load required,

$$W = 2\pi C (r_1 - r_2) = 2\pi \times 44.6 (196.5 - 178.5) = 5045 \text{ N}$$



## Centrifugal Clutch

The centrifugal clutches are usually incorporated into the motor pulleys. It consists of a number of shoes on the inside of a rim of the pulley, as shown in Fig. 10.28. The outer surface of the shoes is covered with

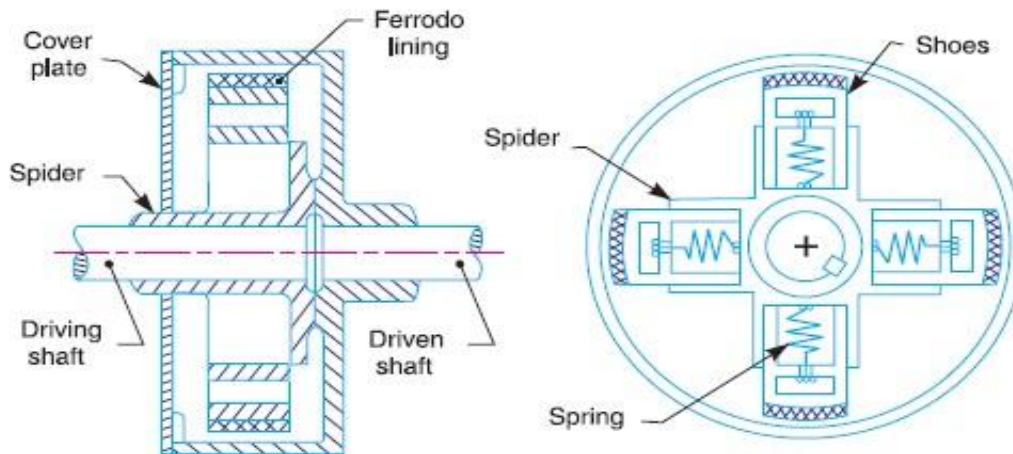

a friction material. These shoes, which can move radially in guides, are held

Against the boss (or spider) on the driving shaft by means of springs. The springs exert a radially inward force which is assumed constant. The mass of the shoe, when revolving, causes it to exert a radially outward force (*i.e.* centrifugal force). The magnitude of this centrifugal force depends upon the speed at which the shoe is revolving. A little consideration will show that when the centrifugal force is less than the spring force, the shoe remains in the same position as when the driving shaft was stationary, but when the centrifugal force is equal to the spring force, the shoe is just floating. When the centrifugal force exceeds the spring force, the shoe moves outward and comes into contact with the driven member and presses against it. The force with which the shoe presses against the driven member is the difference of the centrifugal force and the spring force. The increase of speed causes the shoe to press harder and enables more torque to be transmitted. In order to determine the mass and size of the shoes, the following procedure is adopted:

### Mass of the shoes

Consider one shoe of a centrifugal clutch as shown in Fig Let

$m$  = Mass of each shoe,

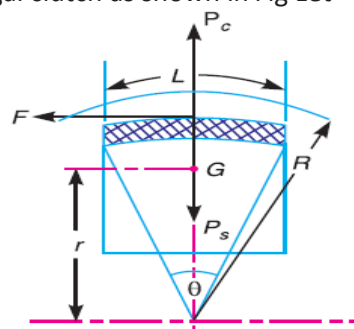

Fig. 10.29. Forces on a shoe of centrifugal clutch.



$n$  = Number of shoes,

$r$  = Distance of centre of gravity of the shoe from the centre of the spider,

$R$  = Inside radius of the pulley rim,

$N$  = Running speed of the pulley in r.p.m.,

$\omega$  = Angular running speed of the pulley in rad/s

=  $2\pi N/60$  rad/s,

$\omega_1$  = Angular speed at which the engagement begins to take place, and

$\alpha$  = Coefficient of friction between the shoe and rim.

We know that the centrifugal force acting on each shoe at the running speed,

$$*P_c = m \cdot \omega^2 \cdot r$$

and the inward force on each shoe exerted by the spring at the speed at which engagement begins to take place,

$$P_s = m (\omega_1)^2 r$$

$\therefore$  The net outward radial force (*i.e.* centrifugal force) with which

The shoe presses against the rim at the running speed =  $P_c - P_s$

The frictional force acting tangentially on each shoe,  $F = \alpha (P_c - P_s)$

$\therefore$  Frictional torque acting on each shoe, =  $F \times R = \alpha (P_c - P_s) R$

Total frictional torque transmitted,

$$T = \alpha (P_c - P_s) R \times n = n.F.R$$

From this expression, the mass of the shoes ( $m$ ) may be evaluated. Size of the shoes

Let  $l$  = Contact length of the shoes,  $b$  = Width of the shoes,

$R$  = Contact radius of the shoes. It is same as the inside radius of the rim of the pulley.

$\theta$  = Angle subtended by the shoes at the centre of the spider in radians.

$p$  = Intensity of pressure exerted on the shoe. In order to ensure reason-able life, the intensity of pressure may be taken as  $0.1 \text{ N/mm}^2$ .

We know that  $\theta = l/R$  rad or  $l = \theta.R$

$\therefore$  Area of contact of the shoe,  $A = l.b$

The force with which the shoe presses against the rim

$$A \times p = l.b.p$$

Since the force with which the shoe presses against the rim at the running speed is  $(P_c - P_s)$ , therefore

$$l.b.p = P_c - P_s$$



## PROBLEMS

### Example 1.

A centrifugal clutch is to transmit 15 kW at 900 r.p.m. The shoes are four in number. The speed at which the engagement begins is 3/4th of the running speed. The inside radius of the pulley rim is 150 mm and the centre of gravity of the shoe lies at 120 mm from the centre of the spider. The shoes are lined with Ferrodo for which the coefficient of friction may be taken as 0.25. Determine: 1. Mass of the shoes, and 2. Size of the shoes, if angle subtended by the shoes at the centre of the spider is  $60^\circ$  and the pressure exerted on the shoes is  $0.1\text{N/mm}^2$ .

#### Solution.:

Given:  $P = 15\text{ kW} = 15 \times 10^3\text{ W}$ ;  $N = 900\text{ r.p.m.}$  or  $\omega = 2\pi \times 900/60 = 94.26\text{ rad/s}$ ;  $n = 4$ ;  $R = 150\text{ mm} = 0.15\text{ m}$ ;  $r = 120\text{ mm} = 0.12\text{ m}$ ;  $\mu = 0.25$

Since the speed at which the engagement begins (*i.e.*  $\omega_1$ ) is 3/4th of the running speed (*i.e.*  $\omega$ ), therefore

$$\omega_1 = \frac{3}{4} \omega = \frac{3}{4} \times 94.26 = 70.7\text{ rad/s}$$

Let  $T =$  Torque transmitted at the running speed.

We know that power transmitted ( $P$ ),

$$P = T \cdot \omega = T \times 94.26 \text{ or } T = 15 \times 10^3 / 94.26 = 159\text{ N-m}$$

Mass of the shoes

Let  $m =$  Mass of the shoes in kg.

We know that the centrifugal force acting on each shoe,

$$P_c = m \cdot \omega^2 \cdot r = m (94.26)^2 \times 0.12 = 1066 m\text{ N}$$

the inward force on each shoe exerted by the spring *i.e.* the centrifugal force at the engagement speed  $\omega_1$ ,

$$P_s = m (\omega_1)^2 r = m (70.7)^2 \times 0.12 = 600 m\text{ N}$$

$\therefore$  Frictional force acting tangentially on each shoe,

$$F = \mu (P_c - P_s) = 0.25 (1066 m - 600 m) = 116.5 m\text{ N}$$

We know that the torque transmitted ( $T$ ),

$$159 = n \cdot F \cdot R = 4 \times 116.5 m \times 0.15 = 70 m \text{ or } m = 2.27\text{ kg}$$



Size of the shoes

Let  $l$  = Contact length of shoes in mm,

$b$  = Width of the shoes in mm,

$\theta$  Angle subtended by the shoes at the centre of the spider in radians

=  $60^\circ = \pi/3$  rad, and

$p$  = Pressure exerted on the shoes in  $\text{N/mm}^2 = 0.1 \text{ N/mm}^2$

$$\text{We know that } l = \theta \cdot R = \frac{\pi}{3} \times 150 = 157.1 \text{ mm}$$

$$l \cdot b \cdot p = P_c - P_s = 1066 \text{ m} - 600 \text{ m} = 466 \text{ m}$$

$$\therefore 157.1 \times b \times 0.1 = 466 \times 2.27 = 1058$$

$$b = 1058/157.1 \times 0.1 = 67.3 \text{ mm}$$

## BRAKES AND DYNAMOMETERS

A *brake* is a device by means of which artificial frictional resistance is applied to a moving machine member, in order to retard or stop the motion of a machine. In the process of performing this function, the brake absorbs either kinetic energy of the moving member or potential energy given up by objects being lowered by hoists, elevators etc

### Single Block or Shoe Brake

A single block or shoe brake is shown in Fig. It consists of a block or shoe which is pressed against the rim of a revolving brake wheel drum. The block is made of a softer material than the rim of the wheel. This type of a brake is commonly used on railway trains and tram cars. The friction between the block and the wheel causes a tangential braking force to act on the wheel, which retard the rotation of the wheel. The block is pressed against the wheel by a force applied to one end of a lever to which the block is rigidly fixed as shown in Fig. 19.1. The other end of the lever is pivoted on a fixed fulcrum  $O$

Let  $P$  = Force applied at the end of the lever

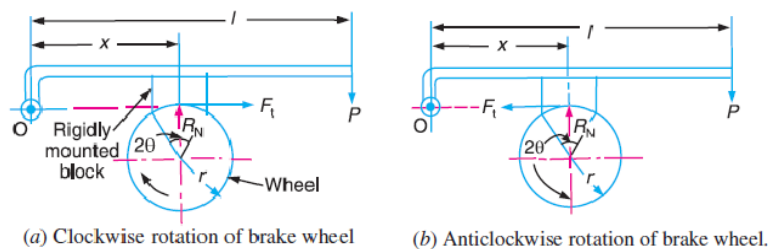

$R_N$  = Normal force pressing the brake block on the wheel,



$r$  = Radius of the wheel,

$2\theta$  = Angle of contact surface of the block,

$\mu$  = Coefficient of friction, and

$F_t$  = Tangential braking force or the frictional force acting at the contact surface of the block and the wheel

If the angle of contact is less than  $60^\circ$ , then it may be assumed that the normal pressure between the block and the wheel is uniform. In such cases, tangential braking force on the wheel,

$$F_t = \mu \cdot R_N \dots (i)$$

The braking torque,  $T_B = F_t \cdot r = \mu \cdot R_N \cdot r \dots (ii)$

Let us now consider the following three cases:

**Case1.** When the line of action of tangential braking force ( $F_t$ ) passes through the fulcrum  $O$  of the lever, and the brake wheel rotates clockwise as shown in Fig. 19.1(a), then for equilibrium, taking moments about the fulcrum.

$$R_N \times x = P \times l \text{ or } R_N = \frac{P \times l}{x}$$

Braking torque,

$$T_B = \mu \cdot R_N \cdot r = \mu \times \frac{P \cdot l}{x} \times r = \frac{\mu \cdot P \cdot l \cdot r}{x}$$

Or, we have

It may be noted that when the brake wheel rotates anticlockwise as shown in Fig. 19.1 (b), then the braking torque is same, i.e.

$$T_B = \mu \cdot R_N \cdot r = \frac{\mu \cdot P \cdot l \cdot r}{x}$$

**Case2.** When the line of action of the tangential braking force ( $F_t$ ) passes through a distance ' $a$ ' below the fulcrum  $O$ , and the brake wheel rotates clockwise as shown in Fig.

When the brake wheel rotates anticlockwise, as shown in Fig. 19.2 (b), then for equilibrium,

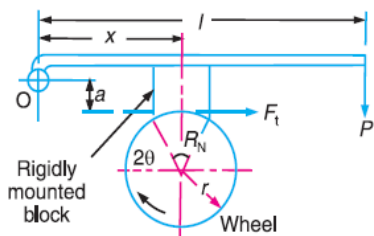

(a) Clockwise rotation of brake wheel.

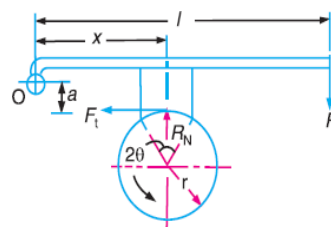

(b) Anticlockwise rotation of brake wheel.

(a), then for equilibrium, taking moments about the fulcrum  $O$ ,



Case 3. When the line of action of the tangential braking force ( $F_t$ ) passes through a distance ' $a$ ' above the fulcrum  $O$ , and the brake wheel rotates clockwise as shown in Fig.

(a), then for equilibrium, taking moments about the fulcrum  $O$ , we have

$$R_N \cdot x = P \cdot l + F_t \cdot a = P \cdot l + \mu \cdot R_N \cdot a$$

$$R_N (x - \mu \cdot a) = P \cdot l \quad \text{or} \quad R_N = \frac{P \cdot l}{x - \mu \cdot a}$$

$$T_B = \mu \cdot R_N \cdot r = \frac{\mu \cdot P \cdot l \cdot r}{x - \mu \cdot a}$$

$$R_N \cdot x = P \cdot l + F_t \cdot a = P \cdot l + \mu \cdot R_N \cdot a$$

$$R_N (x - \mu \cdot a) = P \cdot l$$

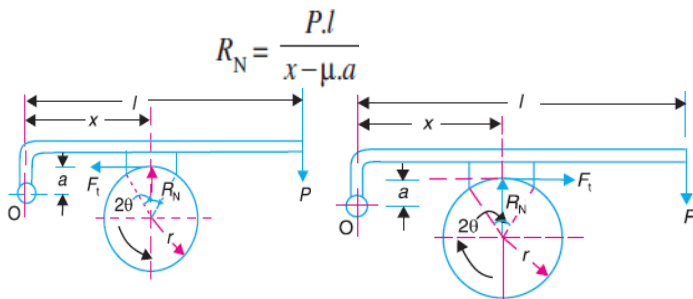

(b) Anticlockwise rotation of brake wheel. (a) Clockwise rotation of brake wheel.

$$T_B = \mu \cdot R_N \cdot r = \frac{\mu \cdot P \cdot l \cdot r}{x - \mu \cdot a}$$

When the brake wheel rotates anticlockwise as shown in Fig. 19.3 (b), then for equilibrium, taking moments about the fulcrum  $O$ , we have

$$R_N \times x + F_t \times a = P \cdot l \quad R_N \times x + \mu \cdot R_N \times a = P \cdot l$$

$$T_B = \mu \cdot R_N \cdot r = \frac{\mu \cdot P \cdot l \cdot r}{x + \mu \cdot a}$$

**Pivoted Block or Shoe Brake :** We have discussed in the previous article that when the angle of contact is less than  $60^\circ$ , then it may be assumed that the normal pressure between the block and the wheel is uniform. But when the angle of contact is greater than  $60^\circ$ , then the unit pressure normal to the surface of contact is less at the ends than at the centre.

Instead of being rigidly attached to the lever. This gives uniform wear of the brake lining in the direction of the applied force. The braking torque of a pivoted block



$$T_B = F_t \times r = \mu' \cdot R_N \cdot r$$

$$\mu' = \text{Equivalent coefficient of friction} = \frac{4\mu \sin \theta}{2\theta + \sin 2\theta},$$

$$\mu = \text{Actual coefficient of friction.}$$

## PROBLEMS

Example1. A single block brake is shown in Fig. 19.5. The diameter of the drum is 250 mm and the angle of contact is  $90^\circ$ . If the operating force of 700 N is applied at the end of a lever and the coefficient of friction

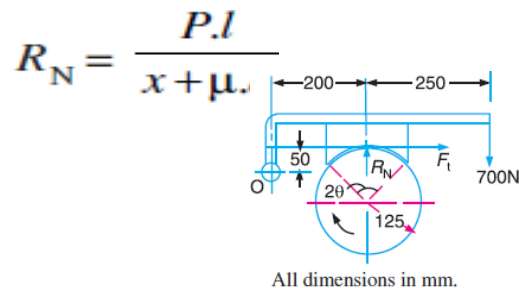

between the drum and the lining is 0.35, Determine the torque that may be transmitted by the

Solution. Given:  $d = 250$  mm or  $r = 125$  mm ;  $2\theta = 90^\circ = \pi / 2$  rad ;  $P = 700$  N ;  $\mu = 0.35$

Since the angle of contact is greater than  $60^\circ$ , therefore equivalent coefficient of friction,

$$\mu' = \frac{4\mu \sin \theta}{2\theta + \sin 2\theta} = \frac{4 \times 0.35 \times \sin 45^\circ}{\pi / 2 + \sin 90^\circ} = 0.385$$

$R_N$  = Normal force pressing the block to the brake drum, and

$F_t$  = Tangential braking force =  $\mu' \cdot R_N$

Taking moments about the fulcrum O, we have

$$700(250 + 200) + F_t \times 50 = R_N \times 200 = \frac{F_t}{\mu'} \times 200 = \frac{F_t}{0.385} \times 200 = 520 F_t$$

$$520 F_t - 50 F_t = 700 \times 450 \text{ or } F_t = 700 \times 450 / 470 = 670 \text{ N}$$

We know that torque transmitted by the block brake,

$$T_B = F_t \times r = 670 \times 125 = 83750 \text{ N-mm} = 83.75 \text{ N-m}$$



Example 2. A bicycle and rider of mass 100 kg are travelling at the rate of 16 km/h on a level road. A brake is applied to the rear wheel which is 0.9 m in diameter and this is the only resistance acting. How far will the bicycle travel and how many turns will it make before it comes to rest? The pressure applied on the brake is 100 N and  $\mu = 0.05$ .

Solution. Given:  $m = 100$  kg,  $v = 16$  km/h =  $4.44$  m/s ;  $D = 0.9$  m ;  $R$

$N = 100$  N;  $\mu = 0.05$

Distance travelled by the bicycle before it comes to rest

Let  $x$  = Distance travelled (in meters) by the bicycle before it comes to rest.

We know that tangential braking force acting at the point of contact of the brake wheel,

$$F_t = \mu \cdot R_N = 0.05 \times 100 = 5 \text{ N}$$

$$= F_t \times x = 5 \times x = 5x \text{ N-m} \quad (i)$$

We know that kinetic energy of the bicycle

$$\begin{aligned} &= \frac{m \cdot v^2}{2} = \frac{100(4.44)^2}{2} \\ &= 986 \text{ N-m} \quad \dots (ii) \end{aligned}$$

In order to bring the bicycle to rest, the work done against friction must be equal to kinetic energy of the bicycle. Therefore equating equations (i) and (ii),

$$5x = 986 \text{ or } x = 986/5 = 197.2 \text{ m}$$

Number of revolutions made by the bicycle before it comes to rest

Let  $N$  = Required number of revolutions.

We know that distance travelled by the bicycle ( $x$ ),  $197.2 = \pi DN = \pi \times 0.9N = 2.83N$

$$N = 197.2 / 2.83 = 70$$

### Double Block or Shoe Brake

When a single block brake is applied to a rolling wheel, an additional load is thrown on the shaft bearings due to the normal force ( $R_N$ ). This produces bending of the shaft. In order to overcome this drawback, a double block or shoe brake, as shown in Fig. 19.9, is used. It consists of two brake blocks applied at the opposite ends of a diameter of the wheel which eliminate or reduce the unbalanced force on the shaft. The brake is set by a spring which pulls the upper ends of the brake arms together. When a force  $P$  is applied to the bell crank lever, the spring is compressed and the brake is released. This type of brake is often used on electric cranes and the force  $P$  is produced by an electromagnet or solenoid.



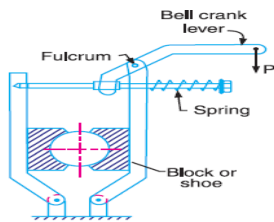

Fig. 19.9. Double block or shoe brake.

In a double block brake, the braking action is doubled by the use of two blocks and these blocks may be operated practically by the same force which will operate one. In case of double block or shoe brake, the braking torque is given by

$$T_B = (F_{t1} + F_{t2}) r$$

Where  $F_{t1}$  and  $F_{t2}$  are the braking forces on the two blocks.

### Internal Expanding Brake

An internal expanding brake consists of two shoes  $S_1$  and  $S_2$  as shown in Fig.

19.24. The outer surface of the shoes are lined with some friction material (usually with Ferodo) to increase the coefficient of friction and to prevent wearing away of the metal. Each shoe is pivoted at one end about a fixed fulcrum  $O_1$  and  $O_2$  and made to contact a cam at the other end. When the cam rotates, the shoes are pushed outwards against the rim of the drum. The friction between the shoes and the drum produces the braking torque and hence reduces the speed of the drum. The shoes are normally held in off position by a spring as shown in Fig. 19.24. The drum encloses the entire mechanism to keep out dust and moisture. This type of brake is commonly used in motor cars and light trucks.

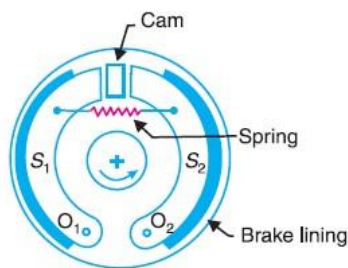

Fig. 19.24. Internal expanding brake.

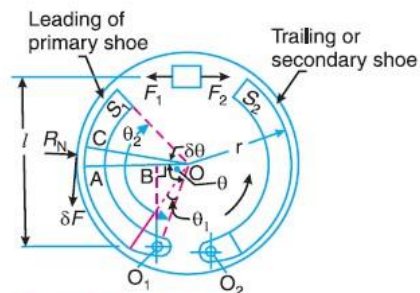

Fig. 19.25. Forces on an internal expanding brake.

We shall now consider the forces acting on such a brake, when the drum rotates in the anticlockwise direction as shown in Fig. 19.25. It may be noted that for the anticlockwise direction, the left hand shoe is known as *leading* or *primary shoe* while the right hand shoe is known as *trailing* or *secondary shoe*.

Let  $r$  = Internal radius of the wheelrim,

$b$  = Width of the brake lining,

$p_1$  = Maximum intensity of normal pressure,

$p_N$  = Normal pressure,



$F_1$  = Force exerted by the cam on the leading shoe, and

$F_2$  = Force exerted by the cam on the trailing shoe.

Consider a small element of the brake lining

$AC$  subtending an angle  $\delta\theta$  at the centre. Let  $OA$  makes an angle  $\theta$  with  $OO_1$  as shown in Fig. 19.25. It is assumed that the pressure distribution on the shoe is nearly uniform, however the friction lining wears out more at the free end. Since the shoe turns about  $O_1$ , therefore the rate of wear of the shoe lining at  $A$  will be proportional to the radial displacement of that point. The rate of wear of the shoe lining varies directly as the perpendicular distance from  $O_1$  to  $OA$ , i.e.

$O_1B$ . From the geometry of the figure,

$$O_1B = OO_1 \sin \theta$$

Normal pressure at  $A$ ,

$$p_N \propto \sin \theta \quad \text{or} \quad p_N = p_1 \sin \theta$$

$\therefore$  Normal force acting on the element,

$$\delta R_N = \text{Normal pressure} \times \text{Area of the element}$$

$$= p_N (b.r.\delta\theta) = p_1 \sin \theta (b.r.\delta\theta)$$

and total braking torque about  $O$  for whole of one shoe,

$$\begin{aligned} T_B &= \mu p_1 b r^2 \int_{\theta_1}^{\theta_2} \sin \theta d\theta = \mu p_1 b r^2 [-\cos \theta]_{\theta_1}^{\theta_2} \\ &= \mu p_1 b r^2 (\cos \theta_1 - \cos \theta_2) \end{aligned} \quad )$$

Moment of normal force  $\delta R_N$  of the element about the fulcrum  $O_1$ ,

$$\delta M_N = \delta R_N \times O_1B = \delta R_N (OO_1 \sin \theta)$$

$$= p_1 \sin \theta (b.r.\delta\theta) (OO_1 \sin \theta) = p_1 \sin^2 \theta (b.r.\delta\theta) OO_1$$

$\therefore$  Total moment of normal forces about the fulcrum  $O_1$ ,

$$= p_1 . b.r. OO_1 \int_{\theta_1}^{\theta_2} \frac{1}{2} (1 - \cos 2\theta) d\theta \quad \dots \left[ \because \sin^2 \theta = \frac{1}{2} (1 - \cos 2\theta) \right]$$

$$= \frac{1}{2} p_1 . b.r. OO_1 \left[ \theta - \frac{\sin 2\theta}{2} \right]_{\theta_1}^{\theta_2}$$

$$= \frac{1}{2} p_1 . b.r. OO_1 \left[ \theta_2 - \frac{\sin 2\theta_2}{2} - \theta_1 + \frac{\sin 2\theta_1}{2} \right]$$

$$= \frac{1}{2} p_1 . b.r. OO_1 \left[ (\theta_2 - \theta_1) + \frac{1}{2} (\sin 2\theta_1 - \sin 2\theta_2) \right]$$

$$M_N = \int_{\theta_1}^{\theta_2} p_1 \sin^2 \theta (b.r.\delta\theta) OO_1 = p_1 . b.r. OO_1 \int_{\theta_1}^{\theta_2} \sin^2 \theta d\theta$$



Now for leading shoe, taking moments about the fulcrum  $O_1$ ,

$$F_1 \times l = M_N - M_F$$

and for trailing shoe, taking moments about the fulcrum  $O_2$ ,

$$F_2 \times l = M_N + M_F = \mu p_1 b r (r \sin \theta - OO_1 \cos \theta) \dots (\because \sin \theta \cos \theta = \frac{1}{2} \sin 2\theta)$$

$$= \mu p_1 \sin \theta (b.r.\delta\theta) (r - OO_1 \cos \theta)$$

$$= \mu.p_1.b.r(r \sin \theta - OO_1 \sin \theta \cos \theta)\delta\theta$$

$$= \mu.p_1.b.r \left( r \sin \theta - \frac{OO_1}{2} \sin 2\theta \right) \delta\theta \quad \dots (\because 2 \sin \theta \cos \theta = \sin 2\theta)$$

$\therefore$  Total moment of frictional force about the fulcrum  $O_1$ ,

$$M_F = \mu p_1 b r \int_{\theta_1}^{\theta_2} \left( r \sin \theta - \frac{OO_1}{2} \sin 2\theta \right) d\theta$$

$$= \mu p_1 b r \left[ -r \cos \theta + \frac{OO_1}{4} \cos 2\theta \right]_{\theta_1}^{\theta_2}$$

$$= \mu p_1 b r \left[ -r \cos \theta_2 + \frac{OO_1}{4} \cos 2\theta_2 + r \cos \theta_1 - \frac{OO_1}{4} \cos 2\theta_1 \right]$$

$$= \mu p_1 b r \left[ r(\cos \theta_1 - \cos \theta_2) + \frac{OO_1}{4} (\cos 2\theta_2 - \cos 2\theta_1) \right]$$

## Braking of a Vehicle

In a four wheeled moving vehicle, the brakes may be applied to the rear wheels only, the front wheels only, and all the four wheels. In all the above mentioned three types of braking, it is required to determine the retardation of the vehicle when brakes are applied. Since the vehicle retards, therefore it is a problem of dynamics. But it may be reduced to an equivalent problem of statics by including the inertia force in the system of forces actually applied to the vehicle. The inertia force is equal and opposite to the braking force causing retardation.

Now, consider a vehicle moving up an inclined plane, as shown in Fig.

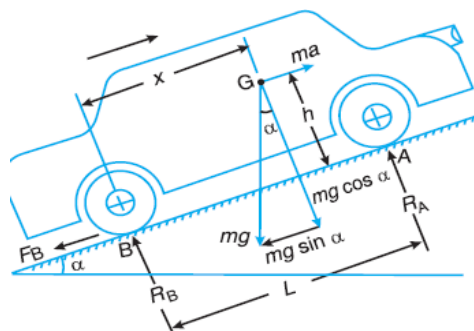

Let  $\alpha$  = Angle of inclination of the plane to the horizontal,  
 $m$  = Mass of the vehicle in kg (such that its weight is  $m.g$  newtons),  
 $h$  = Height of the C.G. of the vehicle above the road surface in metres,  
 $x$  = Perpendicular distance of C.G. from the rear axle in metres,  
 $L$  = Distance between the centres of the rear and front wheels of the vehicle in metres,  
 $R_A$  = Total normal reaction between the ground and the front wheels in newtons,  
 $R_B$  = Total normal reaction between the ground and the rear wheels in newtons,  
 $\mu$  = Coefficient of friction between the tyres and road surface, and  
 $a$  = Retardation of the vehicle in  $m/s^2$ .

We shall now consider the above mentioned three cases of braking, one by one. In all these cases, the braking force acts in the opposite direction to the direction of motion of the vehicle.

When the brakes are applied to the rear wheels only

It is a common way of braking the vehicle in which the braking force acts at the rear wheels only.

Let  $F_B$  = Total braking force (in newtons) acting at the rear wheels due to the application of the brakes. Its maximum value is  $\mu.R_B$ .

The various forces acting on the vehicle are shown in Fig. For the equilibrium of the vehicle, the forces acting on the vehicle must be in equilibrium.

Resolving the forces parallel to the plane,

$$F_B + m.g.\sin\alpha = m.a. \dots (i)$$

Resolving the forces perpendicular to the plane,

$$R_A + R_B = m g \cos\alpha \dots (ii)$$

Taking moments about  $G$ , the centre of gravity of the vehicle

$$F_B \times h + R_B \times x = R_A (L-x) \dots (iii)$$

Substituting the value of  $F_B = \mu.R_B$ , and  $R_A = m.g\cos\alpha - R_B$  [from equation (ii)] in the above expression, we have

$$\mu.R_B \times h + R_B \times x = (m.g\cos\alpha - R_B) (L-x) \quad R_B (L + \mu.h) = m.g\cos\alpha(L-x)$$

$$R_B = \frac{m.g \cos\alpha(L-x)}{L + \mu.h}$$

and

$$R_A = m.g \cos\alpha - R_B = m.g \cos\alpha - \frac{m.g \cos\alpha(L-x)}{L + \mu.h}$$

$$= \frac{m.g \cos\alpha(x + \mu.h)}{L + \mu.h}$$

We know from equation (i),

$$a = \frac{F_B + m.g \sin\alpha}{m} = \frac{F_B}{m} + g \sin\alpha = \frac{\mu.R_B}{m} + g \sin\alpha$$

$$= \frac{\mu.g \cos\alpha(L-x)}{L + \mu.h} + g \sin\alpha \dots \text{(Substituting the value of } R_B \text{)}$$



When the brakes are applied to front wheels only

It is a very rare way of braking the vehicle, in which the braking force acts at the front wheels only.

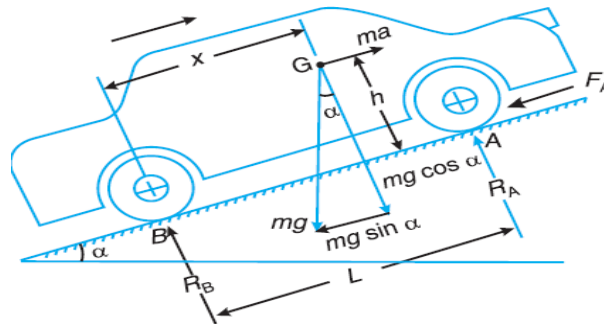

Let  $F_A$  = Total braking force (in newtons) acting at the front wheels due to the application of brakes. Its maximum value is  $\mu.R_A$ .

The various forces acting on the vehicle are shown in Fig. Resolving the forces parallel to the plane,

$$F_A + m.g \sin \alpha = m.a \dots (i)$$

Resolving the forces perpendicular to the plane,

$$R_A + R_B = m.g \cos \alpha \dots (ii)$$

Taking moments about  $G$ , the centre of gravity of the vehicle,

$$F_A \times h + R_B \times x = R_A (L - x)$$

Substituting the value of  $F_A = \mu.R_A$  and  $R_B = m.g \cos \alpha - R_A$  [from equation (ii)] in the above expression, we have

$$\mu.R_A \times h + (m.g \cos \alpha - R_A) x = R_A (L - x)$$

$$\mu.R_A \times h + m.g \cos \alpha \times x = R_A \times L$$

$$\therefore R_A = \frac{m.g \cos \alpha \times x}{L - \mu.h}$$

and

$$R_B = m.g \cos \alpha - R_A = m.g \cos \alpha - \frac{m.g \cos \alpha \times x}{L - \mu.h}$$

$$= m.g \cos \alpha \left( 1 - \frac{x}{L - \mu.h} \right) = m.g \cos \alpha \left( \frac{L - \mu.h - x}{L - \mu.h} \right)$$

We know from equation (i),

$$a = \frac{F_A + m.g \sin \alpha}{m} = \frac{\mu.R_A + m.g \sin \alpha}{m}$$

$$= \frac{\mu.m.g \cos \alpha \times x}{(L - \mu.h)m} + \frac{m.g \sin \alpha}{m} \dots \text{(Substituting the value of } R_A \text{)}$$

$$= \frac{\mu.g \cos \alpha \times x}{L - \mu.h} + g \sin \alpha$$



When the brakes are applied to all the fourwheels

This is the most common way of braking the vehicle, in which the braking force acts on both the rear and front wheels.

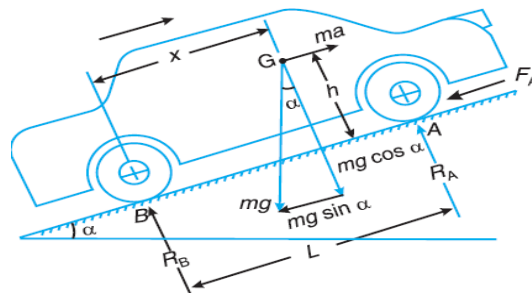

Let  $F_A =$  Braking force provided by the front wheels  $= \mu.R_A$ , and

$F_B =$  Braking force provided by the rear wheels  $= \mu.R_B$ .

Little consideration will show that when the brakes are applied to all the four wheels, the braking distance (i.e. the distance in which the vehicle is brought to rest after applying the brakes) will be the least. It is due to this reason that the brakes are applied to all the four wheels. The various forces acting on the vehicle are shown in fig.

Resolving the forces parallel to the plane,  $F_A + F_B + m.g \sin \alpha = m.a \dots\dots(i)$

Resolving forces vertical to the plane

$$R_A + R_B = m.g \cos \alpha \dots(ii)$$

Taking moments about  $G$ , the centre of gravity of the vehicle,  $(F_A + F_B) h + R_B \times x = R_A(L - x) \dots\dots(iii)$

Substituting the value of  $F_A = \mu.R_A$ ,  $F_B = \mu.R_B$  and  $R_B = m.g \cos \alpha - R_A$

[From equation (ii)] in the above expression,

$$\mu (R_A + R_B) h + (m g \cos \alpha - R_A) x = R_A(L - x)$$

$$\mu (R_A + m g \cos \alpha - R_A) h + (m g \cos \alpha - R_A) x = R_A(L - x) \quad \mu.m.g \cos \alpha \times h + m.g \cos \alpha \times x = R_A \times L$$

$$R_A = \frac{m.g \cos \alpha (\mu.h + x)}{L}$$

$$R_B = m.g \cos \alpha - R_A = m.g \cos \alpha - \frac{m.g \cos \alpha (\mu.h + x)}{L}$$

$$= m.g \cos \alpha \left[ 1 - \frac{\mu.h + x}{L} \right] = m.g \cos \alpha \left( \frac{L - \mu.h - x}{L} \right)$$

Now from equation (i),  $\mu.R_A + \mu.R_B + m.g \sin \alpha = m.a$

$$\mu(R_A + R_B) + m.g \sin \alpha = m.a$$

$$\mu.m.g \cos \alpha + m.g \sin \alpha = m.a \dots [From equation (ii)]$$



$$a = g(\mu \cos \alpha + \sin \alpha)$$

## PROBLEMS

Example 1. A car moving on a level road at a speed 50 km/h has a wheel base 2.8metres, distance of C.G. from ground level 600 mm, and the distance of C.G. from rear wheels 1.2metres. Find the distance travelled by the car before coming to rest when brakes are applied, To the rear wheels, To the front wheels, and To all the four wheels. The coefficient of friction between the tyres and the road may be taken as 0.6.

Solution.

Given :  $u = 50 \text{ km/h} = 13.89 \text{ m/s}$  ;  $L = 2.8 \text{ m}$  ;  $h = 600 \text{ mm} = 0.6 \text{ m}$  ;  $x = 1.2 \text{ m}$  ;  $\mu = 0.6$  Let  $s =$  Distance travelled by the car before coming to rest.

When brakes are applied to the rearwheels

Since the vehicle moves on a level road, therefore retardation of the car,

$$a = \frac{\mu \cdot g(L - x)}{L + \mu \cdot h} = \frac{0.6 \times 9.81(2.8 - 1.2)}{2.8 + 0.6 \times 0.6} = 2.98 \text{ m/s}^2$$

We know that for uniform retardation,

$$s = \frac{u^2}{2a} = \frac{(13.89)^2}{2 \times 2.98} = 32.4 \text{ m}$$

When brakes are applied to the frontwheels

Since the vehicle moves on a level road, therefore retardation of the car,

$$a = \frac{\mu \cdot g \cdot x}{L - \mu \cdot h} = \frac{0.6 \times 9.81 \times 1.2}{2.8 - 0.6 \times 0.6} = 2.9 \text{ m/s}^2$$

We know that for uniform retardation,

When the brakes are applied to all the fourwheels

Since the vehicle moves on a level road, therefore retardation of the car,

$$a = g \cdot \mu = 9.81 \times 0.6 = 5.886 \text{ m/s}^2$$

We know that for uniform retardation,

$$s = \frac{u^2}{2a} = \frac{(13.89)^2}{2 \times 5.886} = 16.4 \text{ m}$$

Example2. A vehicle moving on a rough plane inclined at  $10^\circ$  with the horizontal at a speed of 36 km/h has a wheel base 1.8 metres. The centre of gravity of the vehicle is 0.8 metre from the rear wheels and



0.9 metre above the inclined plane. Find the distance travelled by the vehicle before coming to rest and the time taken to do so when

The vehicle moves up the plane, and

The vehicle moves down the plane.

The brakes are applied to all the four wheels and the coefficient of friction is 0.5.

Solution.

Given :  $\alpha = 10^\circ$ ;  $u = 36 \text{ km/h} = 10 \text{ m/s}$ ;  $L = 1.8 \text{ m}$ ;  $x = 0.8 \text{ m}$ ;  $h = 0.9 \text{ m}$ ;  $\mu = 0.5$  Let  $s =$  Distance travelled by the vehicle before coming to rest, and

$t =$  Time taken by the vehicle in coming to rest.

When the vehicle moves up the plane and brakes are applied to all the four wheels

Since the vehicle moves up the inclined plane, therefore retardation of the vehicle,

$$a = g(\mu \cos \alpha + \sin \alpha) \\ = 9.81(0.5 \cos 10^\circ + \sin 10^\circ) = 9.81(0.5 \times 0.9848 + 0.1736) = 6.53 \text{ m/s}^2$$

We know that for uniform retardation,

$$s = \frac{u^2}{2a} = \frac{(10)^2}{2 \times 6.53} = 7.657 \text{ m}$$

and final velocity of the vehicle ( $v$ ),

$$0 = u + a.t = 10 - 6.53t \quad (\text{Minus sign due to retardation})$$

$$t = 10 / 6.53 = 1.53$$

When the vehicle moves down the plane and brakes are applied to all the four wheels

Since the vehicle moves down the inclined plane, therefore retardation of the vehicle,

$$a = g(\mu \cos \alpha - \sin \alpha) \\ = 9.81(0.5 \cos 10^\circ - \sin 10^\circ) = 9.81(0.5 \times 0.9848 - 0.1736) = 3.13 \text{ m/s}^2$$

We know that for uniform retardation,

$$s = \frac{u^2}{2a} = \frac{(10)^2}{2 \times 3.13} = 16 \text{ m}$$

and final velocity of the vehicle ( $v$ ),

$$0 = u + a.t = 10 - 3.13t \quad \dots (\text{Minus sign due to retardation})$$

$$t = 10 / 3.13 = 3.2 \text{ s}$$

DYNAMOMETER



A dynamometer is a brake but in addition it has a device to measure the frictional resistance. Knowing the frictional resistance, we may obtain the torque transmitted and hence the power of the engine.

## Types of Dynamometers

Absorption dynamometers,  
Transmission dynamometers.

In the *absorption dynamometers*, the entire energy or power produced by the engine is absorbed by the friction resistances of the brake and is transformed into heat, during the process of measurement. But in the *transmission dynamometers*, the energy is not wasted in friction but is used for doing work. The energy or power produced by the engine is transmitted through the dynamometer to some other machines where the power developed is suitably measured.

## Classification of Absorption Dynamometers

1. Prony brake dynamometer, 2. Rope brake dynamometer.

Prony brake dynamometer

A simplest form of an absorption type dynamometer is a prony brake dynamometer, as shown in Fig. It consists of two wooden blocks placed around a pulley fixed to the shaft of an engine whose power is required to be measured. The blocks are clamped by means of two bolts and nuts, as shown in Fig.

A helical spring is provided between the nut and the upper block to adjust the pressure on the pulley to control its speed. The upper block has a long lever attached to it and carries a weight  $W$  at its outer end. A counter weight is placed at the other end of the lever which balances the brake when unloaded. Two stops  $S, S$  are provided to limit the motion of the lever.

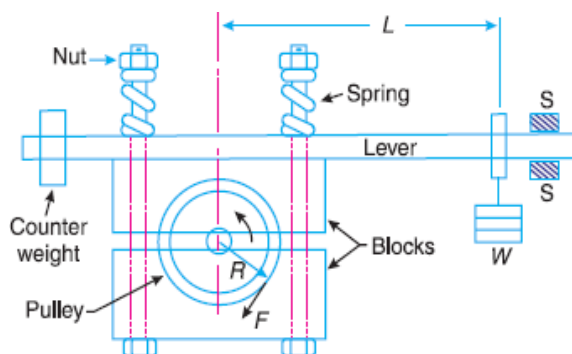

When the brake is to be put in operation, the long end of the lever is loaded with suitable weights  $W$  and the nuts are tightened until the engine shaft runs at a constant speed and the lever is in horizontal



position. Under these conditions, the moment due to the weight  $W$  must balance the moment of the frictional resistance between the blocks and the pulley.

Let  $W$  = Weight at the outer end of the lever in newtons,

$L$  = Horizontal distance of the weight  $W$  from the centre of the pulley in metres,

$F$  = Frictional resistance between the blocks and the pulley in newtons,

$R$  = Radius of the pulley in metres, and

$N$  = Speed of the shaft in r.p.m.

We know that the moment of the frictional resistance or torque on the shaft,

$$T = W.L = F.R \text{ N-m}$$

Work done in one revolution = Torque  $\times$  Angle turned in radians

$$= T \times 2\pi \text{ N-m}$$

$$= T \times 2\pi N \text{ N-m}$$

\_ Work done per minute

$$= T \times 2\pi N \text{ N-m}$$

We know that brake power of the engine

$$B.P. = \frac{\text{Work done per min.}}{60} = \frac{T \times 2\pi N}{60} = \frac{W.L \times 2\pi N}{60} \text{ watts}$$

### Rope Brake Dynamometer

It is another form of absorption type dynamometer which is most commonly used for measuring the brake power of the engine. It consists of one, two or more ropes wound around the flywheel or rim of a pulley fixed rigidly to the shaft of an engine. The upper end of the ropes is attached to a spring balance while the lower end of the ropes is kept in position by applying a dead weight as shown in Fig.19.32. In

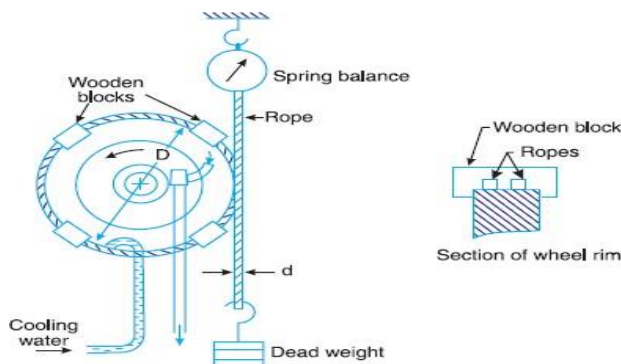

order to prevent the slipping of the rope over the flywheel, wooden blocks are placed at intervals around the circumference of the flywheel.



In the operation of the brake, the engine is made to run at a constant speed. The frictional torque, due to the rope, must be equal to the torque being transmitted by the engine.

Let  $W$  = Dead load in newtons,

$S$  = Spring balance reading in newtons,  $D$  = Diameter of the wheel in metres,  $d$  = diameter of rope in metres, and

$N$  = Speed of the engine shaft in r.p.m.

Net load on the brake =  $(W - S) N$

We know that distance moved in one revolution =  $\pi (D + d)$  m  
Work done per revolution =  $(W - S) \pi (D + d) N$ -m

Work done per minute =  $(W - S) \pi (D + d) NN$ -m

**Brake power of the engine,**

$$\text{B.P.} = \frac{\text{Work done per min}}{60} = \frac{(W - S) \pi (D + d) N}{60} \text{ watts}$$

If the diameter of the rope ( $d$ ) is neglected, then brake power of the engine

$$\text{B.P.} = \frac{(W - S) \pi D N}{60} \text{ watts}$$

Example 1. In a laboratory experiment, the following data were recorded with rope brake: Diameter of the flywheel 1.2 m; diameter of the rope 12.5 mm; speed of the engine 200 r.p.m.; dead load on the brake 600 N; spring balance reading 150 N. Calculate the brake power of the engine.

Solution. Given :  $D = 1.2$  m ;  $d = 12.5$  mm

= 0.0125 m ;  $N = 200$  r.p.m ;  $W = 600$  N ;  $S = 150$  N

We know that brake power of the engine,

$$\text{B.P.} = \frac{(W - S) \pi (D + d) N}{60} = \frac{(600 - 150) \pi (1.2 + 0.0125) 200}{60} = 5715 \text{ W}$$

Classification of Transmission Dynamometers

Epicyclic-train dynamometer,

Belt transmission dynamometer, and

Torsion dynamometer

Epicyclic-train Dynamometer

An epicyclic-train dynamometer, as shown in Fig. 19.33, consists of a simple epicyclic train of gears, *i.e.* a spur gear, an annular gear (a gear having internal teeth) and a pinion. The spur gear is keyed to the engine shaft (*i.e.* driving shaft) and rotates in anticlockwise direction. The annular gear is also keyed to the



driving shaft and rotates in clockwise direction. The pinion or the intermediate gear meshes with both the spur and annular gears. The pinion revolves freely on a lever which is pivoted to the common axis of the driving and driven shafts. A weight  $w$  is placed at the smaller end of the lever in order to keep it in position. A little consideration will show that if the friction of the pinion which the pinion rotates is neglected, then the tangential effort  $P$  exerted by the spur gear on the pinion and the tangential reaction of the annular gear on the pinion are equal.

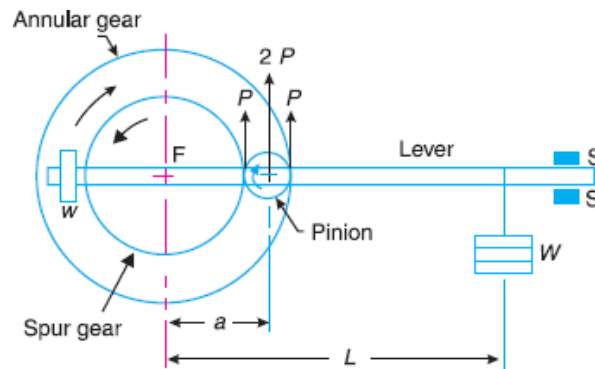

Since these efforts act in the upward direction as shown, therefore total upward force on the lever acting through the axis of the pinion is  $2P$ . This force tends to rotate the lever about its fulcrum and it is balanced by a dead weight  $W$  at the end of the lever. The stops  $S, S$  are provided to control the movement of the lever.

$$2P \times a = W.L \text{ or } P = W.L / 2a$$

$R$  = Pitch circle radius of the spur gear in metres, and

$N$  = Speed of the engine shaft in r.p.m. Torque transmitted,  $T = P.R$

Belt Transmission Dynamometer-Froude or Thronycroft Transmission Dynamometer

$$\text{power transmitted} = \frac{T \times 2\pi N}{60} = \frac{P.R \times 2\pi N}{60} \text{ watts}$$

When the belt is transmitting power from one pulley to another, the tangential effort on the driven pulley is equal to the difference between the tensions in the tight and slack sides of the belt. A belt dynamometer is introduced to measure directly the difference between the tensions of the belt, while it is running.

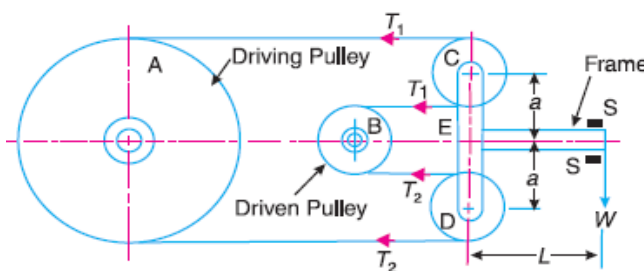

A belt transmission dynamometer, as shown in Fig, is called a Froude or Thronycroft transmission dynamometer. It consists of a pulley A (called driving pulley) which is rigidly fixed to the shaft of an engine whose power is required to be measured. There is another pulley B (called driven pulley) mounted on another shaft to which the power from pulley A is transmitted. The pulleys A and B are connected by means of a continuous belt passing round the two loose pulleys C and D which are mounted on a T-shaped frame. The frame is pivoted at E and its movement is controlled by two stops S, S. Since the tension in the tight side of the belt ( $T_1$ ) is greater than the tension in the slack side of the belt ( $T_2$ ), therefore the total force acting on the pulley C (i.e.  $2T_1$ ) is greater than the total force acting on the pulley D (i.e.  $2T_2$ ). It is thus obvious that the frame causes movement about E in the anticlockwise direction. In order to balance it, a weight W is applied at a distance L from E on the frame as shown in Fig.

Now taking moments about the pivot E, neglecting friction,  $2T_1 \times a = 2T_2 \times a + WL$

Let  $D$  = diameter of the pulley A in metres,  $T_1 - T_2 = \frac{W.L}{2a}$

$N$  = Speed of the engine shaft in r.p.m.

Work done in one revolution =  $(T_1 - T_2)\pi D$  N-m work done per minute =  $(T_1 - T_2)\pi DN$  N-m

$$\therefore \text{ Brake power of the engine, B.P.} = \frac{(T_1 - T_2)\pi DN}{60} \text{ watts}$$

### Torsion Dynamometer

A torsion dynamometer is used for measuring large powers particularly the power transmitted along the propeller shaft of a turbine or motor vessel. A little consideration will show that when the power is being transmitted, then the driving end of the shaft twists through a small angle relative to the driven end of the shaft. The amount of twist depends upon many factors such as torque acting on the shaft ( $T$ ), length of the shaft ( $l$ ), diameter of the shaft ( $D$ ) and modulus of rigidity ( $C$ ) of the material of the shaft. We know that the torsion equation is

$$\frac{T}{J} = \frac{C\theta}{l}$$

where

$\theta$  = Angle of twist in radians, and

$J$  = Polar moment of inertia of the shaft.

For a solid shaft of diameter  $D$ , the polar moment of inertia

$$J = \frac{\pi}{32} \times D^4$$

and for a hollow shaft of external diameter  $D$  and internal diameter  $d$ , the polar moment of inertia,

$$J = \frac{\pi}{32} (D^4 - d^4)$$

From the above torsion equation,

$$T = \frac{CJ}{l} \times \theta = k.\theta$$



Where  $k = C.J/l$  is a constant for a particular shaft. Thus, the torque acting on the shaft is proportional to the angle of twist. This means that if the angle of twist is measured by some means, then the torque and hence the power transmitted may be determined. We know that the power transmitted  $P = 2\pi NT/60$  watts,

Where  $N$  is the speed in r.p.m.

### PROBLEMS

Example 1. A torsion dynamometer is fitted to a propeller shaft of a marine engine. It is found that the shaft twists  $2^\circ$  in a length of 20 metres at 120 r.p.m. If the shaft is hollow with 400 mm external diameter and 300 mm internal diameter, find the power of the engine. Take modulus of rigidity for the shaft material as 80 GPa.

Solution.

Given :  $\theta = 2^\circ = 2 \times \frac{\pi}{180} = 0.035$  rad ;  $l = 20$  m ;  $N = 120$  r.p.m. ;  $D = 400$  mm = 0.4 m ;

$d = 300$  mm = 0.3 m ;  $C = 80$  GPa =  $80 \times 10^9$  N/m<sup>2</sup>

We know that polar moment of inertia of the shaft

$$J = \frac{\pi}{32}(D^4 - d^4) = \frac{\pi}{32}[(0.4)^4 - (0.3)^4] = 0.0017 \text{ m}^4$$

and torque applied to the shaft,

$$T = \frac{C.J}{l} \times \theta = \frac{80 \times 10^9 \times 0.0017}{20} \times 0.035 = 238 \times 10^3 \text{ N-m}$$

We know that power of the engine,

$$P = \frac{T \times 2\pi N}{60} = \frac{238 \times 10^3 \times 2\pi \times 120}{60} = 2990 \times 10^3 \text{ W} = 2990 \text{ kW}$$



## Turning Moment and Flywheel

The turning moment diagram (also known as crank- effort diagram) is the graphical representation of the turning moment or crank-effort for various positions of the crank. It is plotted on cartesian co-ordinates, in which the turning moment is taken as the ordinate and crank angle as abscissa.

Turning diagram for a single Cylinder Double acting Steam Engine:

A turning moment diagram for a single cylinder double acting steam engine is shown in Fig. 16.1. The vertical ordinate represents the turning moment and the horizontal ordinate represents the crank angle. the turning moment on the crankshaft,

$$T = F_p \times r \left( \sin \theta + \frac{\sin 2\theta}{2\sqrt{n^2 - \sin^2 \theta}} \right)$$

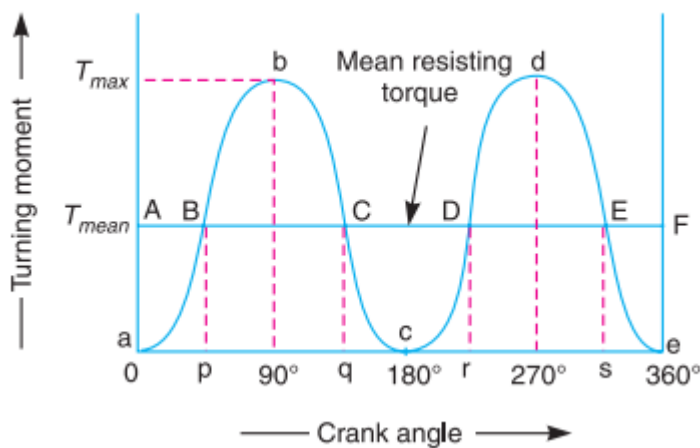

Turning moment diagram for a single cylinder, double acting steam engine.

FP = Piston effort, r = Radius of crank,

n = Ratio of the connecting rod length and radius of crank, and  $\theta$  = Angle turned by the crank from inner dead centre.

From the above expression, we see that the turning moment (T) is zero, when the crank angle ( $\theta$ ) is zero. It is maximum when the crank angle is  $90^\circ$  and it is again zero when crank angle is  $180^\circ$ . This is shown by the curve abc in Fig. 16.1 and it represents the turning moment diagram for outstroke. The curve cde is the turning moment diagram for instroke and is somewhat similar to the curve abc.

Notes: 1. When the turning moment is positive (i.e. when the engine torque is more than the mean resisting torque) as shown between points B and C (or D and E) in Fig. 16.1, the crankshaft accelerates and the work is done by the steam.

When the turning moment is negative (i.e. when the engine torque is less than the mean resisting torque) as shown between points C and D in Fig. 16.1, the crankshaft retards and the work is done on the steam

. T = Torque on the crankshaft at any instant, and

T<sub>mean</sub> = Mean resisting torque.



Then accelerating torque on the rotating parts of the engine

$$= T - T_{\text{mean}}$$

If  $(T - T_{\text{mean}})$  is positive, the flywheel accelerates and if  $(T - T_{\text{mean}})$  is negative, then the flywheel retards.

Turning Moment Diagram for a Four Stroke Cycle Internal Combustion Engine:

A turning moment diagram for a four stroke cycle internal combustion engine is shown in Fig. 16.2. We know that in a four stroke cycle internal combustion engine, there is one working stroke after the crank has turned through two revolutions, i.e.  $720^\circ$  (or  $4\pi$  radians).

Turning moment diagram for a four stroke cycle internal combustion engine..

Turning Moment Diagram for a Multi-cylinder Engine:

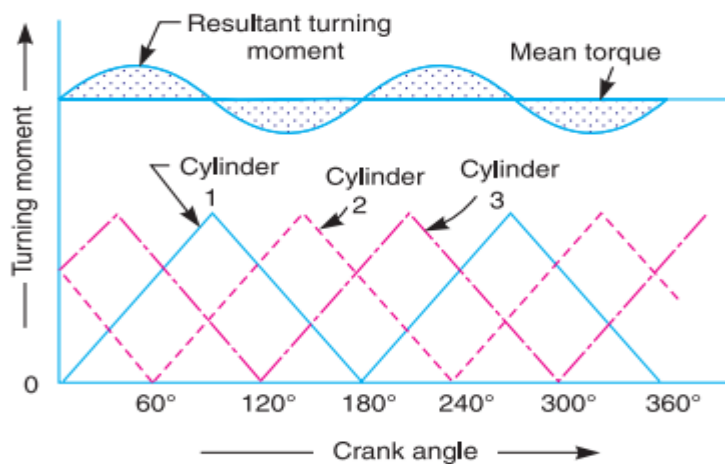

Turning moment diagram

for a multi-cylinder engine.

Fluctuation of Energy:

Let the energy in the flywheel at A = E, then from Fig.

Let the energy in the flywheel at A = E, then from Fig. 16.4, we have

$$\text{Energy at B} = E + a_1$$

$$\text{Energy at C} = E + a_1 - a_2$$

$$\text{Energy at D} = E + a_1 - a_2 + a_3$$

$$\text{Energy at E} = E + a_1 - a_2 + a_3 - a_4$$

$$\text{Energy at F} = E + a_1 - a_2 + a_3 - a_4 + a_5$$

$$\text{Energy at G} = E + a_1 - a_2 + a_3 - a_4 + a_5 - a_6 = \text{Energy at A (i.e. cycle repeats after G)}$$

Let us now suppose that the greatest of these energies is at B and least at E. Therefore,

Maximum energy in flywheel

$$= E + a$$

Minimum energy in the flywheel

$$= E + a_1 - a_2 + a_3 - a_4$$



∴ Maximum fluctuation of energy,

$\Delta E = \text{Maximum energy} - \text{Minimum energy}$

$$= (E + a_1) - (E + a_1 - a_2 + a_3 - a_4) = a_2 - a_3 + a_4$$

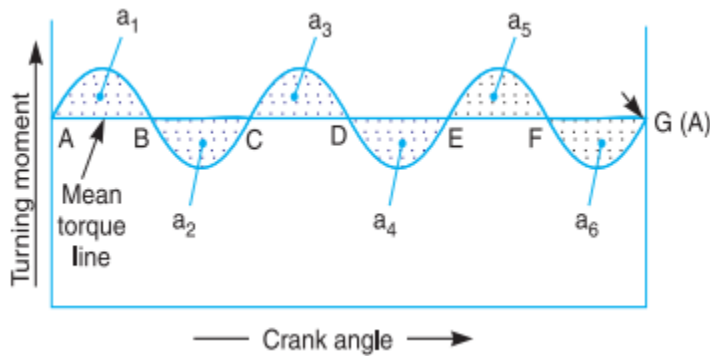

Determination of maximum fluctuation of energy.

Coefficient of Fluctuation of Energy:

It may be defined as the ratio of the maximum fluctuation of energy to the work done per cycle.

Mathematically, coefficient of fluctuation of energy,

$$C_E = \frac{\text{Maximum fluctuation of energy}}{\text{Work done per cycle}}$$

Work done per cycle =  $T_{\text{mean}} \times \theta$

$T_{\text{mean}}$  = Mean torque, and

$\theta$  = Angle turned (in radians), in one revolution.

=  $2\pi$ , in case of steam engine and two stroke internal combustion engines

=  $4\pi$ , in case of four stroke internal combustion engines.

The mean torque ( $T_{\text{mean}}$ ) in N-m may be obtained by using the following relation

$$T_{\text{mean}} = \frac{P \times 60}{2\pi N}$$

Coefficient of Fluctuation of Speed:

The difference between the maximum and minimum speeds during a cycle is called the maximum fluctuation of speed. The ratio of the maximum fluctuation of speed to the mean speed is called the coefficient of fluctuation of speed.

$N_1$  and  $N_2$  = Maximum and minimum speeds in r.p.m. during the cycle, and

$$N = \text{Mean speed in r.p.m.} = \frac{N_1 + N_2}{2}$$

Coefficient of fluctuation of speed



$$C_s = \frac{N_1 - N_2}{N} = \frac{2(N_1 - N_2)}{N_1 + N_2}$$

$$= \frac{\omega_1 - \omega_2}{\omega} = \frac{2(\omega_1 - \omega_2)}{\omega_1 + \omega_2} \quad \dots(\text{In terms of angular speeds})$$

$$= \frac{v_1 - v_2}{v} = \frac{2(v_1 - v_2)}{v_1 + v_2} \quad \dots(\text{In terms of linear speeds})$$

Note. The reciprocal of the coefficient of fluctuation of speed is known as coefficient of steadiness and is denoted by m

$$m = \frac{1}{C_s} = \frac{N}{N_1 - N_2}$$

### Flywheel

A flywheel used in machines serves as a reservoir, which stores energy during the period when the supply of energy is more than the requirement, and releases it during the period when the requirement of energy is more than the supply.

☐ In case of steam engines, internal combustion engines, reciprocating compressors and pumps, the energy is developed during one stroke and the engine is to run for the whole cycle on the energy produced during this one stroke.

☐ For example, in internal combustion engines, the energy is developed only during expansion or power stroke which is much more than the engine load and no energy is being developed during suction, compression and exhaust strokes in case of four stroke engines and during compression in case of two stroke engines.

☐ The excess energy developed during power stroke is absorbed by the flywheel and releases it to the crankshaft during other strokes in which no energy is developed, thus rotating the crankshaft at a uniform speed.

☐ A little consideration will show that when the flywheel absorbs energy, its speed increases and when it releases energy, the speed decreases. Hence a flywheel does not maintain a constant speed, it simply reduces the fluctuation of speed.

☐ In other words, a flywheel controls the speed variations caused by the fluctuation of the engine turning moment during each cycle of operation.

☐ In machines where the operation is intermittent like punching machines, shearing machines, rivetting machines, crushers, etc., the flywheel stores energy from the power source during the greater portion of the operating cycle and gives it up during a small period of the cycle. Thus, the energy from the power source to the machines is supplied practically at a constant rate throughout the operation.

Energy stored in Flywheel:

When a flywheel absorbs energy, its speed increases and when it gives up energy, its speed decreases.

Let m = Mass of the flywheel in kg,



$k$  = Radius of gyration of the flywheel in metres,

$I$  = Mass moment of inertia of the flywheel about its axis of rotation in  $\text{kg}\cdot\text{m}^2 = m\cdot k^2$ ,

$N_1$  and  $N_2$  = Maximum and minimum speeds during the cycle in r.p.m.,  $\omega_1$  and  $\omega_2$  = Maximum and minimum angular speeds during the cycle in rad/s,

$$N = \text{Mean speed in r.p.m.} = \frac{N_1 + N_2}{2}$$

$$\omega = \text{Mean angular speed during the cycle in rad/s} = \frac{\omega_1 + \omega_2}{2}$$

$$C_s = \text{Coefficient of fluctuation of speed} = \frac{N_1 - N_2}{N} \text{ or } \frac{\omega_1 - \omega_2}{\omega}$$

We know that the mean kinetic energy of the flywheel,

$$E = \frac{1}{2}I\omega^2 = \frac{1}{2}m.k^2.\omega^2$$

As the speed of the flywheel changes from  $\omega_1$  to  $\omega_2$ , the maximum fluctuation of energy,

$$\Delta E = \text{Maximum K.E.} - \text{Minimum K.E.}$$

$$= \frac{1}{2}I(\omega_1)^2 - \frac{1}{2}I(\omega_2)^2 = \frac{1}{2}I[(\omega_1)^2 - (\omega_2)^2]$$

$$= \frac{1}{2}I(\omega_1 + \omega_2)(\omega_1 - \omega_2) = I\omega(\omega_1 - \omega_2)$$

.....(i)

$$= I\omega^2 \left( \frac{\omega_1 - \omega_2}{\omega} \right)$$

$$= I\omega^2 C_s = m.k^2.\omega^2 C_s$$

.....(ii)

$$= 2.E.C_s$$

.....(iii)

he

radius of gyration ( $k$ ) may be taken equal to the mean radius of the rim ( $R$ ), because the thickness of rim is very small as compared to the diameter of rim. Therefore, substituting  $k = R$ , in equation (ii), we have

$$\Delta E = m.R^2.\omega^2.C_s = m.v^2.C_s$$

$v$  = Mean linear velocity (*i.e.* at the mean radius) in m/s

Problems:

The mass of flywheel of an engine is 6.5 tonnes and the radius of gyration is 1.8 metres. It is found from the turning moment diagram that the fluctuation of energy is 56 kN-m. If the mean speed of the engine is 120 r.p.m., find the maximum and minimum speeds.

Given :  $m = 6.5 \text{ t} = 6500 \text{ kg}$  ;  $k = 1.8 \text{ m}$  ;  $\Delta E = 56 \text{ kN}\cdot\text{m} = 56 \times 10^3 \text{ N}\cdot\text{m}$  ;  $N = 120 \text{ r.p.m.}$

Let  $N_1$  and  $N_2$  = Maximum and minimum speeds respectively. We know that fluctuation of energy ( $\Delta E$ ),



$$56 \times 10^3 = \frac{\pi^2}{900} \times m.k^2 . N (N_1 - N_2) = \frac{\pi^2}{900} \times 6500 (1.8)^2 120 (N_1 - N_2)$$

$$= 27\,715 (N_1 - N_2)$$

$$\therefore N_1 - N_2 = 56 \times 10^3 / 27\,715 = 2 \text{ r.p.m.} \quad \dots(i)$$

We also know that mean speed ( $N$ ),

$$120 = \frac{N_1 + N_2}{2} \text{ or } N_1 + N_2 = 120 \times 2 = 240 \text{ r.p.m.} \quad \dots(ii)$$

From equations (i) and (ii),

$$N_1 = 121 \text{ r.p.m., and } N_2 = 119 \text{ r.p.m.} \quad \text{Ans.}$$

2. The turning moment diagram for a petrol engine is drawn to the following scales : Turning moment, 1 mm = 5 N-m ; crank angle, 1 mm =  $1^\circ$ . The turning moment diagram repeats itself at every half revolution of the engine and the areas above and below the mean turning moment line taken in order are 295, 685, 40, 340, 960, 270 mm<sup>2</sup>. The rotating parts are equivalent to a mass of 36 kg at a radius of gyration of 150 mm. Determine the coefficient of fluctuation of speed when the engine runs at 1800 r.p.m.

Given :  $m = 36 \text{ kg}$  ;  $k = 150 \text{ mm} = 0.15 \text{ m}$  ;  $N = 1800 \text{ r.p.m.}$  or  $\omega = 2\pi \times 1800/60 = 188.52 \text{ rad/s}$

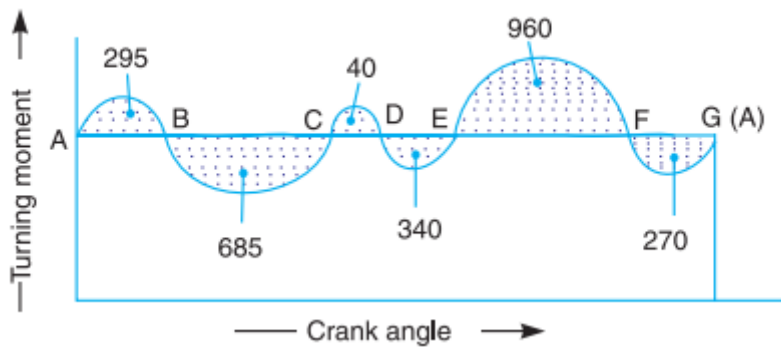

Since the turning moment

scale is 1 mm = 5 N-m and crank angle scale is 1 mm =  $1^\circ = \pi/180 \text{ rad}$ , therefore,

1 mm<sup>2</sup> on turning moment diagram

$$= 5 \times \frac{\pi}{180} = \frac{\pi}{36} \text{ N-m}$$

Let the total energy at A = E,

Energy at B = E + 295

... (Maximum energy)

Energy at C = E + 295 - 685 = E - 390

Energy at D = E - 390 + 40 = E - 350

Flywheel of an electric motor.

Energy at E = E - 350 - 340 = E - 690 ... (Minimum energy)

Energy at F = E - 690 + 960 = E + 270

Energy at G = E + 270 - 270 = E = Energy at A



We know that maximum fluctuation of energy,

$$\Delta E = \text{Maximum energy} - \text{Minimum energy} = (E + 295) - (E - 690) = 985 \text{ mm}^2$$

$$= 985 \times \frac{\pi}{36} = 86 \text{ N} \cdot \text{m} = 86 \text{ J}$$

Let  $C_s =$  Coefficient of fluctuation of speed.

We know that maximum fluctuation of energy ( $\Delta E$ ),

$$86 = m \cdot k^2 \omega^2 \cdot C_s = 36 \times (0.15)^2 \times (188.52)^2 C_s = 28\,787 C_s$$

$$\therefore C_s = 86 / 28\,787 = 0.003 \text{ or } 0.3\% \quad \text{Ans.}$$

Dimensions of the Flywheel Rim

Consider a rim of the flywheel as shown in Fig

$D =$  Mean diameter of rim in metres,

$R =$  Mean radius of rim in metres,  $A =$  Cross-sectional area of rim in  $\text{m}^2$ ,  $\rho =$  Density of rim material in  $\text{kg}/\text{m}^3$ ,  $N =$  Speed of the flywheel in r.p.m.,

$\omega =$  Angular velocity of the flywheel in  $\text{rad}/\text{s}$ ,  $v =$  Linear velocity at the mean radius in  $\text{m}/\text{s}$

$$= \omega \cdot R = \pi D \cdot N / 60, \text{ and}$$

$\sigma =$  Tensile stress or hoop stress in  $\text{N}/\text{m}^2$  due to the centrifugal force

Consider a small element of the rim as shown shaded in Fig. 16.17. Let it subtends an angle  $\delta\theta$  at the centre of the flywheel.

$$\text{Volume of the small element} = A \times R \cdot \delta\theta$$

$\therefore$  Mass of the small element

$$dm = \text{Density} \times \text{volume} = \rho \cdot A \cdot R \cdot \delta\theta$$

and centrifugal force on the element, acting radially outwards,

$$dF = dm \cdot \omega^2 \cdot R = \rho \cdot A \cdot R^2 \cdot \omega^2 \cdot \delta\theta$$

Vertical component of  $dF = dF \cdot \sin \theta = \rho \cdot A \cdot R^2 \cdot \omega^2 \cdot \delta\theta \cdot \sin \theta$

Total vertical upward force tending to burst the rim across the diameter X Y.

$$\begin{aligned} &= \rho \cdot A \cdot R^2 \cdot \omega^2 \int_0^\pi \sin \theta \cdot d\theta = \rho \cdot A \cdot R^2 \cdot \omega^2 \left[ -\cos \theta \right]_0^\pi \\ &= 2\rho \cdot A \cdot R^2 \cdot \omega^2 \quad \dots (i) \end{aligned}$$

This vertical upward force will produce tensile stress or hoop stress (also called centrifugal stress or circumferential stress), and it is resisted by  $2P$ , such that



$$2P = 2\sigma.A \quad \dots (ii)$$

Equating equations (i) and (ii),

$$2.\rho.A.R^2.\omega^2 = 2\sigma.A$$

$$\sigma = \rho.R^2.\omega^2 = \rho.v^2 \quad \dots(\because v = \omega.R)$$

$$\therefore v = \sqrt{\frac{\sigma}{\rho}} \quad \dots(iii)$$

We know that mass of the rim,

$$m = \text{Volume} \times \text{density} = \pi D.A.\rho$$

$$\therefore A = \frac{m}{\pi.D.\rho} \quad \dots(iv)$$

From equations (iii) and (iv), we may find the value of the mean radius and cross-sectional area of the rim.

Note: If the cross-section of the rim is a rectangular, then

$$A = b \times t$$

where

b = Width of the rim, and t = Thickness of the rim.

Problem: The turning moment diagram for a multi-cylinder engine has been drawn to a scale of 1 mm to 500 N-m torque and 1 mm to 6° of crank displacement. The intercepted areas between output torque curve and mean resistance line taken in order from one end, in sq. mm are

– 30, + 410, – 280, + 320, – 330, + 250, – 360, + 280, – 260 sq. mm, when the engine is running at 800 r.p.m.

The engine has a stroke of 300 mm and the fluctuation of speed is not to exceed  $\pm 2\%$  of the mean speed. Determine a suitable diameter and cross-section of the flywheel rim for a limiting value of the safe centrifugal stress of 7 MPa. The material density may be assumed as 7200 kg/m<sup>3</sup>. The width of the rim is to be 5 times the thickness.

Given : N = 800 r.p.m. or  $\omega = 2\pi \times 800 / 60 = 83.8$  rad/s; \*Stroke = 300 mm ;  $\sigma = 7$  MPa =  $7 \times 10^6$  N/m<sup>2</sup> ;  $\rho = 7200$  kg/m<sup>3</sup>

Since the fluctuation of speed is  $\pm 2\%$  of mean speed, therefore total fluctuation of speed,

$$\omega_1 - \omega_2 = 4\% \omega = 0.04 \omega \text{ and coefficient of fluctuation of speed,}$$

$$C_s = \frac{\omega_1 - \omega_2}{\omega} = 0.04$$

Diameter of the flywheel rim

D = Diameter of the flywheel rim in metres, and v = Peripheral velocity of the flywheel rim in m/s.

We know that centrifugal stress ( $\sigma$ ),

$$7 \times 10^6 = \rho.v^2 = 7200 v^2 \text{ or } v^2 = 7 \times 10^6 / 7200 = 972.2$$

$$v = 31.2 \text{ m/s}$$



∴ We know that  $v = \pi D.N/60$

$$D = v \times 60 / \pi N = 31.2 \times 60 / \pi \times 800 = 0.745 \text{ m}$$

Cross-section of the flywheel rim

t = Thickness of the flywheel rim in metres, and b = Width of the flywheel rim in metres = 5 t

∴ Cross-sectional area of flywheel rim,

$$A = b.t = 5 t \times t = 5 t^2$$

First of all, let us find the mass (m) of the flywheel rim. The turning moment diagram is

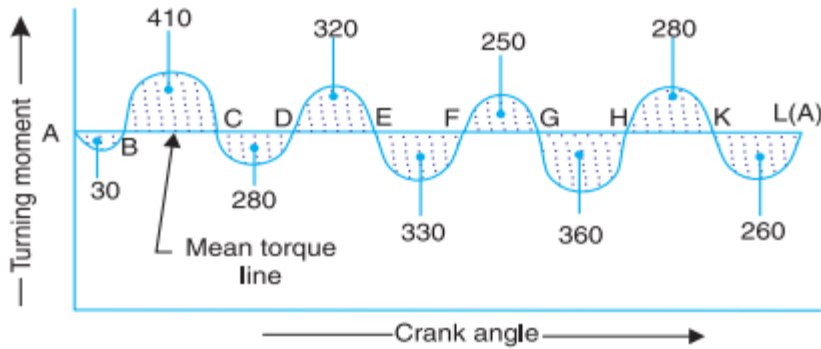

Since the

turning moment scale is 1 mm = 500 N-m and crank angle scale is 1 mm =  $6^\circ = \pi / 30$  rad, therefore  
1 mm<sup>2</sup> on the turning moment diagram

$$= 500 \times \pi / 30 = 52.37 \text{ N-m}$$

Let the energy at A = E, then referring to Fig

Energy at B = E - 30 ... (Minimum energy)

Energy at C = E - 30 + 410 = E + 380

Energy at D = E + 380 - 280 = E + 100

Energy at E = E + 100 + 320 = E + 420 ... (Maximum energy)

Energy at F = E + 420 - 330 = E + 90

Energy at G = E + 90 + 250 = E + 340

Energy at H = E + 340 - 360 = E - 20

Energy at K = E - 20 + 280 = E + 260

Energy at L = E + 260 - 260 = E = Energy at A

We know that maximum fluctuation of energy,

$\Delta E = \text{Maximum energy} - \text{Minimum energy}$

$$= (E + 420) - (E - 30) = 450 \text{ mm}^2 = 450 \times 52.37 = 23566 \text{ N-m}$$

We also know that maximum fluctuation of energy ( $\Delta E$ ),

$$23566 = m.v^2.CS = m \times (31.2)^2 \times 0.04 = 39 m$$

$$m = 23566 / 39 = 604 \text{ kg}$$

∴ We know that mass of the flywheel rim (m),

$$604 = \text{Volume} \times \text{density} = \pi D.A.\rho$$



$$= \pi \times 0.745 \times 5t^2 \times 7200 = 84\,268 t^2$$

$$t^2 = 604 / 84\,268 = 0.00717 \text{ m}^2 \text{ or } t = 0.085 \text{ m} = 85 \text{ mm Ans. } b = 5t = 5 \times 85 = 425 \text{ mm}$$



## INDUSTRIAL APPLICATIONS

### 1. Mining & motor vehicles



## TUTORIAL QUESTIONS

1. Define 'inertia force' and 'inertia torque'.
2. Derive an expression for the inertia force due to reciprocating mass in reciprocating engine, neglecting the mass of the connecting rod.
3. Describe with a neat sketch the working of a single plate friction clutch.
4. Which of the two assumptions-uniform intensity of pressure or uniform rate of wear, would you make use of in designing friction clutch and why ?
5. Determine the maximum, minimum and average pressure in plate clutch when the axial force is 4 kN. The inside radius of the contact surface is 50 mm and the outside radius is 100 mm. Assume uniform wear.
6. A single plate clutch, with both sides effective, has outer and inner diameters 300 mm and 200 mm respectively. The maximum intensity of pressure at any point in the contact surface is not to exceed 0.1 N/mm<sup>2</sup>. If the coefficient of friction is 0.3, determine the power transmitted by a clutch at a speed 2500 r.p.m.
7. A cone clutch with cone angle 20° is to transmit 7.5 kW at 750 r.p.m. The normal intensity of pressure between the contact faces is not to exceed 0.12 N/mm<sup>2</sup>. The coefficient of friction is 0.2. If face width is 15 th of mean diameter, find : 1. the main dimensions of the clutch, and 2. axial force required while running
8. An engine flywheel has a mass of 6.5 tonnes and the radius of gyration is 2 m. If the maximum and minimum speeds are 120 r. p. m. and 118 r. p. m. respectively, find maximum fluctuation of energy.
9. In a turning moment diagram, the areas above and below the mean torque line taken in order are 4400, 1150, 1300 and 4550 mm<sup>2</sup> respectively. The scales of the turning moment diagram are:Turning moment, 1 mm = 100 N-m ; Crank angle, 1 mm = 1°Find the mass of the flywheel required to keep the speed between 297 and 303 r.p.m., if the radius of gyration is 0.525 m.
10. A steam engine runs at 150 r.p.m. Its turning moment diagram gave the following area measurements in mm<sup>2</sup> taken in order above and below the mean torque line: 500, – 250, 270, – 390, 190, – 340, 270, – 250 The scale for the turning moment is 1 mm = 500 N-m, and for crank angle is 1mm = 5°. The fluctuation of speed is not to exceed ± 1.5% of the mean, determine the cross-section of the rim of the flywheel assumed rectangular with axial dimension equal to 1.5 times the radial dimension. The hoop stress is limited to 3 MPa and the density of the material of the flywheel is 7500 kg/m<sup>3</sup>.
11. Draw the turning moment diagram of a single cylinder double acting steam engine.



12. Explain the turning moment diagram of a four stroke cycle internal combustion engine.
13. Define the terms 'coefficient of fluctuation of energy' and 'coefficient of fluctuation of speed', in the case of flywheels.



## ASSIGNMENT QUESTIONS

1. Describe with a neat sketch a centrifugal clutch and deduce an equation for the total torque transmitted.
2. Describe with a neat sketch the working of a single plate friction clutch.
3. Establish a formula for the maximum torque transmitted by a single plate clutch of external and internal radii  $r_1$  and  $r_2$ , if the limiting coefficient of friction is  $\mu$  and the axial spring load is  $W$ . Assume that the pressure intensity on the contact faces is uniform.
4. A centrifugal clutch has four shoes which slide radially in a spider keyed to the driving shaft and make contact with the internal cylindrical surface of a rim keyed to the driven shaft. When the clutch is at rest, each shoe is pulled against a stop by a spring so as to leave a radial clearance of 5 mm between the shoe and the rim. The pull exerted by the spring is then 500 N. The mass centre of the shoe is 160 mm from the axis of the clutch. If the internal diameter of the rim is 400 mm, the mass of each shoe is 8 kg, the stiffness of each spring is 50 N/mm and the coefficient of friction between the shoe and the rim is 0.3 ; find the power transmitted by the clutch at 500 r.p.m.
5. A centrifugal clutch is to transmit 15 kW at 900 r.p.m. The shoes are four in number. The speed at which the engagement begins is  $\frac{3}{4}$ th of the running speed. The inside radius of the pulley rim is 150 mm and the centre of gravity of the shoe lies at 120 mm from the centre of the spider. The shoes are lined with Ferrodo for which the coefficient of friction may be taken as 0.25. Determine : 1. Mass of the shoes, and 2. Size of the shoes, if angle subtended by the shoes at the centre of the spider is  $60^\circ$  and the pressure exerted on the shoes is  $0.1 \text{ N/mm}^2$ .
6. The contact surfaces in a cone clutch have an effective diameter of 75 mm. The semi-angle of the cone is  $15^\circ$ . The coefficient of friction is 0.3. Find the torque required to produce slipping of the clutch if an axial force applied is 180 N. This clutch is employed to connect an electric motor running uniformly at 1000 r.p.m. with a flywheel which is initially stationary. The flywheel has a mass of 13.5 kg and its radius of gyration is 150 mm. Calculate the time required for the flywheel to attain full speed and also the energy lost in the slipping of the clutch.
7. What is the function of a flywheel? How does it differ from that of a governor?
8. A punching machine makes 25 working strokes per minute and is capable of punching 25 mm diameter holes in 18 mm thick steel plates having an ultimate shear strength 300 MPa. The punching operation takes place during  $\frac{1}{10}$ th of a revolution of the crankshaft. Estimate the power needed for the driving motor, assuming a mechanical efficiency of 95 percent. Determine suitable dimensions for the rim cross-section of the flywheel, having width equal to twice thickness. The flywheel is to revolve at 9 times the speed of the crankshaft. The permissible



coefficient of fluctuation of speed is 0.1. The flywheel is to be made of cast iron having a working stress (tensile) of 6 MPa and density of 7250 kg/m<sup>3</sup>. The diameter of the flywheel must not exceed 1.4 m owing to space restrictions. The hub and the spokes may be assumed to provide 5% of the rotational inertia of the wheel.

9. The turning moment diagram for a multi-cylinder engine has been drawn to a scale of 1 mm to 500 N-m torque and 1 mm to 6° of crank displacement. The intercepted areas between output torque curve and mean resistance line taken in order from one end, in sq. mm are – 30, + 410, – 280, + 320, – 330, + 250, – 360, + 280, – 260 sq. mm, when the engine is running at 800 r.p.m. The engine has a stroke of 300 mm and the fluctuation of speed is not to exceed  $\pm 2\%$  of the mean speed. Determine a suitable diameter and cross-section of the flywheel rim for a limiting value of the safe centrifugal stress of 7 MPa. The material density may be assumed as 7200 kg/m<sup>3</sup>. The width of the rim is to be 5 times the thickness.
10. The equation of the turning moment curve of a three crank engine is  $(5000 + 1500 \sin 3\theta)$  N-m, where  $\theta$  is the crank angle in radians. The moment of inertia of the flywheel is 1000 kg-m<sup>2</sup> and the mean speed is 300 r.p.m. Calculate : 1. power of the engine, and 2. the maximum fluctuation of the speed of the flywheel in percentage when (i) the resisting torque is constant, and (ii) the resisting torque is  $(5000 + 600 \sin \theta)$  N-m.





---

# UNIT 4

## BALANCING AND VIBRATION

---



## **Course Objectives**

To study about the balancing, unbalancing of rotating masses and the effect of Dynamics of undesirable vibrations

## **Course Outcomes**

Ability to understand the importance of balancing and implications of computed results in dynamics to improve the design of a mechanism



## **Balancing of Rotating Masses**

The high speed of engines and other machines is a common phenomenon now-a- days. It is, therefore, very essential that all the rotating and reciprocating parts should be completely balanced as far as possible. If these parts are not properly balanced, the dynamic forces are set up. These forces not only increase the loads on bearings and stresses in the various members, but also produce unpleasant and even dangerous vibrations. In this chapter we shall discuss the balancing of unbalanced forces caused by rotating masses, in order to minimize pressure on the main bearings when an engine is running.

We have already discussed, that whenever a certain mass is attached to a rotating shaft, it exerts some centrifugal force, whose effect is to bend the shaft and to produce vibrations in it. In order to prevent the effect of centrifugal force, another mass is attached to the opposite side of the shaft, at such a position so as to balance the effect of the centrifugal force of the first mass. This is done in such a way that the centrifugal force of both the masses are made to be equal and opposite. The process of providing the second mass in order to counteract the effect of the centrifugal force of the first mass, is called ***balancing of rotating masses***.

The following cases are important from the subject point of view:

- Balancing of a single rotating mass by a single mass rotating in the same plane.
- Balancing of a single rotating mass by two masses rotating in different planes.
- Balancing of different masses rotating in the same plane.
- Balancing of different masses rotating in different planes.
- We shall now discuss these cases, in detail, in the following pages.

### **Balancing of a Single Rotating Mass By a Single Mass Rotating in the Same Plane**

Consider a disturbing mass  $m_1$  attached to a shaft rotating at  $\omega$  rad/s as shown in Fig. Let  $r_1$  be the radius of rotation of the mass  $m_1$  (*i.e.* distance between the axis of rotation of the shaft and the centre of gravity of the mass  $m_1$ ). We know that the centrifugal force exerted by the mass  $m_1$  on the shaft,

$$F_{C1} = m_1 \cdot \omega^2 \cdot r_1$$

This centrifugal force acts radially outwards and thus produces bending moment on the shaft. In order to counteract the effect of this force, a balancing mass ( $m_2$ ) may be attached in the same plane of rotation as that of disturbing mass ( $m_1$ ) such that the centrifugal forces due to the two masses are equal and opposite



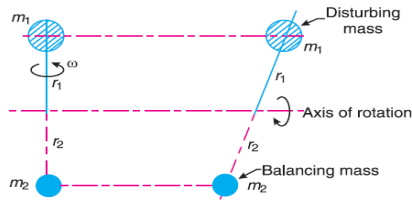

Let  $r_2$  = Radius of rotation of the balancing mass  $m_2$  (i.e. distance between the axis of rotation of the shaft and the centre of gravity of mass  $m_2$ ).

∴ Centrifugal force due to mass  $m_2$

$$F_{C2} = m_2 \cdot \omega^2 \cdot r_2$$

Equating equations (i) and (ii),

$$m_1 \cdot \omega^2 \cdot r_1 = m_2 \cdot \omega^2 \cdot r_2 \quad \text{or} \quad m_1 \cdot r_1 = m_2 \cdot r_2$$

#### Balancing of a Single Rotating Mass By Two Masses Rotating in Different Planes

We have discussed in the previous article that by introducing a single balancing mass in the same plane of rotation as that of disturbing mass, the centrifugal forces are balanced. In other words, the two forces are equal in magnitude and opposite in direction. But this type of arrangement for balancing gives rise to a couple which tends to rock the shaft in its bearings. Therefore in order to put the system in complete balance, two balancing masses are placed in two different planes, parallel to the plane of rotation of the disturbing mass, in such a way that they satisfy the following two conditions of equilibrium.

The net dynamic force acting on the shaft is equal to zero. This requires that the line of action of three centrifugal forces must be the same. In other words, the centre of the masses of the system must lie on the axis of rotation. This is the condition for **static balancing**. The net couple due to the dynamic forces acting on the shaft is equal to zero. In other words, the algebraic sum of the moments about any point in the plane must be zero.

The conditions (1) and (2) together give **dynamic balancing**. The following two possibilities may arise while attaching the two balancing masses:

The plane of the disturbing mass may be in between the planes of the two balancing masses, and the plane of the disturbing mass may lie on the left or right of the two planes containing the balancing masses.

We shall now discuss both the above cases one by one



### When the plane of the disturbing mass lies in between the planes of the two balancing masses

Consider a disturbing mass  $m$  lying in a plane  $A$  to be balanced by two rotating masses  $m_1$  and  $m_2$  lying in two different planes  $L$  and  $M$  as shown in Fig. Let  $r$ ,  $r_1$  and  $r_2$  be the radii of rotation of the masses in planes  $A$ ,  $L$  and  $M$  respectively.

Let  $l_1$  = Distance between the planes  $A$  and  $L$ ,

$l_2$  = Distance between the planes  $A$  and  $M$ , and

$l$  = Distance between the planes  $L$  and  $M$

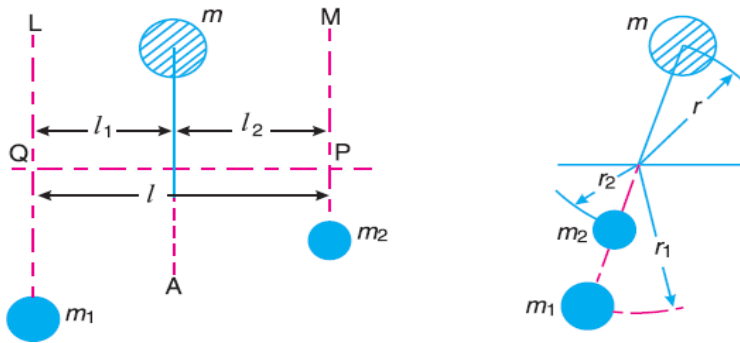

We know that the centrifugal force exerted by the mass  $m$  in the plane  $A$ ,

$$F_C = m \cdot \omega^2 \cdot r$$

Similarly, the centrifugal force exerted by the mass  $m_1$  in the plane  $L$ ,

$$F_{C1} = m_1 \cdot \omega^2 \cdot r_1$$

and, the centrifugal force exerted by the mass  $m_2$  in the plane  $M$ ,

$$F_{C2} = m_2 \cdot \omega^2 \cdot r_2$$

Since the net force acting on the shaft must be equal to zero, therefore the centrifugal force on the disturbing mass must be equal to the sum of the centrifugal forces on the balancing masses, therefore

$$F_C = F_{C1} + F_{C2} \quad \text{or} \quad m \cdot \omega^2 \cdot r = m_1 \cdot \omega^2 \cdot r_1 + m_2 \cdot \omega^2 \cdot r_2$$

$$m \cdot r = m_1 \cdot r_1 + m_2 \cdot r_2 \quad \dots (i)$$

Now in order to find the magnitude of balancing force in the plane  $L$  (or the dynamic force at the bearing  $Q$  of a shaft), take moments about  $P$  which is the point of intersection of the plane  $M$  and the axis of rotation. Therefore

$$F_{C1} \times l = F_C \times l_2 \quad \text{or} \quad m_1 \cdot \omega^2 \cdot r_1 \times l = m \cdot \omega^2 \cdot r \times l_2$$

$$m_1 \cdot r_1 \cdot l = m \cdot r \cdot l_2 \quad \text{or} \quad m_1 \cdot r_1 = m \cdot r \times \frac{l_2}{l}$$



Similarly, in order to find the balancing force in plane  $M$  (or the dynamic force at the bearing  $P$  of a shaft), take moments about  $Q$  which is the point of intersection of the plane  $L$  and the axis of rotation. Therefore

$$F_{C2} \times l = F_C \times l_1 \quad \text{or} \quad m_2 \cdot \omega^2 \cdot r_2 \times l = m \cdot \omega^2 \cdot r \times l_1$$

$$m_2 \cdot r_2 \cdot l = m \cdot r \cdot l_1 \quad \text{or} \quad m_2 \cdot r_2 = m \cdot r \times \frac{l_1}{l}$$

It may be noted that equation (i) represents the condition for static balance, When the plane of the disturbing mass lies on one end of the planes of the balancing masses

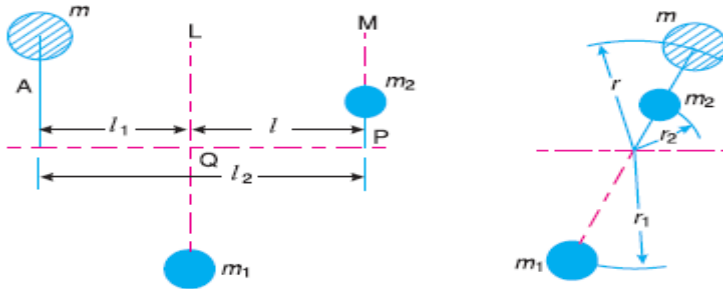

In this case, the mass  $m$  lies in the plane  $A$  and the balancing masses lie in the planes  $L$  and  $M$ , as shown in Fig. As discussed above, the following conditions must be satisfied in order to balance the system, i.e.

$$F_C + F_{C2} = F_{C1} \quad \text{or} \quad m \cdot \omega^2 \cdot r + m_2 \cdot \omega^2 \cdot r_2 = m_1 \cdot \omega^2 \cdot r_1$$

$$m \cdot r + m_2 \cdot r_2 = m_1 \cdot r_1 \quad \dots (iv)$$

Now, to find the balancing force in the plane  $L$  (or the dynamic force at the bearing  $Q$  of a shaft), take moments about  $P$  which is the point of intersection of the plane  $M$  and the axis of rotation. Therefore

$$F_{C1} \times l = F_C \times l_2 \quad \text{or} \quad m_1 \cdot \omega^2 \cdot r_1 \times l = m \cdot \omega^2 \cdot r \times l_2$$

$$m_1 \cdot r_1 \cdot l = m \cdot r \cdot l_2 \quad \text{or} \quad m_1 \cdot r_1 = m \cdot r \times \frac{l_2}{l} \quad \dots (v)$$

Similarly, to find the balancing force in the plane  $M$  (or the dynamic force at the bearing  $P$  of a shaft), take moments about  $Q$  which is the point of intersection of the plane  $L$  and the axis of rotation. Therefore

$$F_{C2} \times l = F_C \times l_1 \quad \text{or} \quad m_2 \cdot \omega^2 \cdot r_2 \times l = m \cdot \omega^2 \cdot r \times l_1$$

$$m_2 \cdot r_2 \cdot l = m \cdot r \cdot l_1 \quad \text{or} \quad m_2 \cdot r_2 = m \cdot r \times \frac{l_1}{l} \quad \dots (vi)$$

### Balancing of Several Masses Rotating in the Same Plane

Consider any number of masses (say four) of magnitude  $m_1, m_2, m_3$  and  $m_4$  at distances of  $r_1, r_2, r_3$  and  $r_4$  from the axis of the rotating shaft. Let  $\theta_1, \theta_2, \theta_3$  and  $\theta_4$  be the angles of these masses with the



horizontal line  $OX$ , as shown in Fig. Let these masses rotate about an axis through  $O$  and perpendicular to the plane of paper, with a constant angular velocity of  $\omega$  rad/s.

The magnitude and position of the balancing mass may be found out analytically or graphically as discussed below:

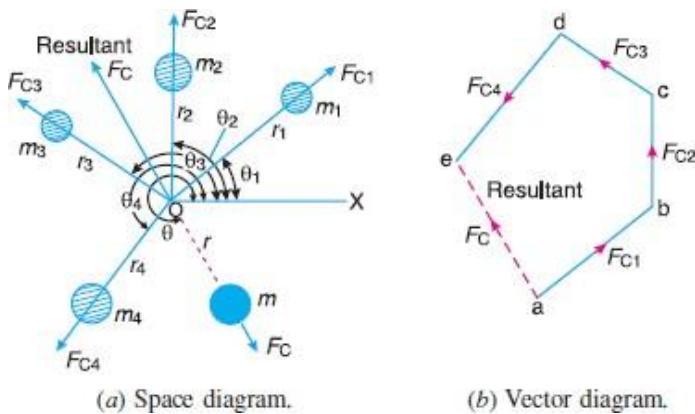

### Analytical method

The magnitude and direction of the balancing mass may be obtained, analytically, as discussed below:

First of all, find out the centrifugal force\* (or the product of the mass and its radius of rotation) exerted by each mass on the rotating shaft.

Resolve the centrifugal forces horizontally and vertically and find their sums, i.e.  $\Sigma H$  and  $\Sigma V$ . We know that Sum of horizontal components of the centrifugal forces,

$$\Sigma H = m_1 \cdot r_1 \cos \theta_1 + m_2 \cdot r_2 \cos \theta_2 + \dots$$

sum of vertical components of the centrifugal forces,

$$\Sigma V = m_1 \cdot r_1 \sin \theta_1 + m_2 \cdot r_2 \sin \theta_2 + \dots$$

Magnitude of the resultant centrifugal force,

$$F_C = \sqrt{(\Sigma H)^2 + (\Sigma V)^2}$$

If  $\theta$  is the angle, which the resultant force makes with the horizontal, then

$$\tan \theta = \Sigma V / \Sigma H$$

The balancing force is then equal to the resultant force, but in **opposite direction**.

Now find out the magnitude of the balancing mass, such that

$F_C = m \cdot r$  where  $m$  = Balancing mass, and

$r$  = Its radius of rotation.

Graphical method



The magnitude and position of the balancing mass may also be obtained graphically as discussed below:

First of all, draw the space diagram with the positions of the several masses,

Find out the centrifugal force (or product of the mass and radius of rotation) exerted by each mass on the rotating shaft.

Now draw the vector diagram with the obtained centrifugal forces (or the product of the masses and their radii of rotation), such that ab represents the centrifugal force exerted by the mass  $m_1$  (or  $m_1 \cdot r_1$ ) in magnitude and direction to some suitable scale. Similarly, draw bc, cd and de to represent centrifugal forces of other masses  $m_2$ ,  $m_3$  and  $m_4$  (or  $m_2 \cdot r_2$ ,  $m_3 \cdot r_3$  and  $m_4 \cdot r_4$ ).

Now, as per polygon law of forces, the closing side ae represents the resultant force in magnitude and direction.

The balancing force is, then, equal to the resultant force, but in **opposite direction**.

Now find out the magnitude of the balancing mass ( $m$ ) at a given radius of rotation ( $r$ ), such that

$$m \cdot \omega^2 \cdot r = \text{Resultant centrifugal force}$$

$$m \cdot r = \text{Resultant of } m_1 \cdot r_1, m_2 \cdot r_2, m_3 \cdot r_3 \text{ and } m_4 \cdot r_4$$

**Example 1.** Four masses  $m_1$ ,  $m_2$ ,  $m_3$  and  $m_4$  are 200 kg, 300 kg, 240 kg and 260 kg respectively. The corresponding radii of rotation are 0.2 m, 0.15 m, 0.25 m and 0.3 m respectively and the angles between successive masses are  $45^\circ$ ,  $75^\circ$  and  $135^\circ$ . Find the position and magnitude of the balance mass required, if its radius of rotation is 0.2 m.

**Solution.** Given :  $m_1 = 200 \text{ kg}$  ;  $m_2 = 300 \text{ kg}$  ;  $m_3 = 240 \text{ kg}$  ;  $m_4 = 260 \text{ kg}$  ;  $r_1 = 0.2 \text{ m}$  ;  $r_2 = 0.15 \text{ m}$  ;  $r_3 = 0.25 \text{ m}$  ;  $r_4 = 0.3 \text{ m}$  ;  $\theta_1 = 0^\circ$  ;  $\theta_2 = 45^\circ$  ;  $\theta_3 = 45^\circ + 75^\circ = 120^\circ$  ;  $\theta_4 = 45^\circ + 75^\circ + 135^\circ = 255^\circ$  ;  $r = 0.2 \text{ m}$

Let  $m =$  Balancing mass, and

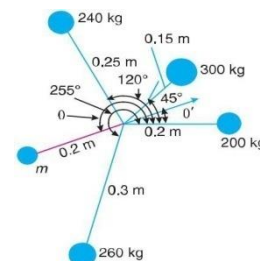

$F =$  The angle which the balancing mass makes with  $m_1$ .

Since the magnitude of centrifugal forces are proportional to the product of each mass and its radius, therefore

$$m_1 \cdot r_1 = 200 \cdot 0.2 = 40 \text{ kg-m} \quad m_2 \cdot r_2 = 300 \cdot 0.15 = 45 \text{ kg-m} \quad m_3 \cdot r_3 = 240 \cdot 0.25 = 60 \text{ kg-m} \quad m_4 \cdot r_4 = 260 \cdot 0.3 = 78 \text{ kg-m}$$

The problem may, now, be solved either analytically or graphically. But we shall solve the problem by both the methods one by one.

### Analytical method

Resolving  $m_1 \cdot r_1$ ,  $m_2 \cdot r_2$ ,  $m_3 \cdot r_3$  and  $m_4 \cdot r_4$  horizontally,



$$\Sigma H = m_1 \cdot r_1 \cos \theta_1 + m_2 \cdot r_2 \cos \theta_2 + m_3 \cdot r_3 \cos \theta_3 + m_4 \cdot r_4 \cos \theta_4$$

$$= 40 \cos 0^\circ + 45 \cos 45^\circ + 60 \cos 120^\circ + 78 \cos 255^\circ$$

$$= 40 + 31.8 - 30 - 20.2 = 21.6 \text{ kg-m}$$

Now resolving vertically,

$$\Sigma V = m_1 \cdot r_1 \sin \theta_1 + m_2 \cdot r_2$$

$$\sin \theta_2 + m_3 \cdot r_3 \sin \theta_3 + m_4 \cdot r_4 \sin \theta_4$$

$$= 40 \sin 0^\circ + 45 \sin 45^\circ + 60 \sin 120^\circ + 78 \sin 255^\circ$$

$$= 0 + 31.8 + 52 - 75.3 = 8.5 \text{ kg-m}$$

$$\therefore \text{Resultant, } R = \sqrt{(\Sigma H)^2 + (\Sigma V)^2} = \sqrt{(21.6)^2 + (8.5)^2} = 23.2 \text{ kg-m}$$

$$m \cdot r = R = 23.2 \quad \text{or} \quad m = 23.2 / r = 23.2 / 0.2 = 116 \text{ kg}$$

Since  $\theta'$  is the angle of the resultant  $R$  from the horizontal mass of 200 kg, therefore the angle of the balancing mass from the horizontal mass of 200 kg,

$$= 180^\circ + 21.48^\circ = 201.48^\circ \text{ Ans.}$$

### Balancing of Reciprocating Masses

The various forces acting on the reciprocating parts of an engine. The resultant of all the forces acting on the body of the engine due to inertia forces only is known as **unbalanced force** or **shaking force**. Thus if the resultant of all the forces due to inertia effects is zero, then there will be no unbalanced force, but even then an unbalanced couple or shaking couple will be present. Consider a horizontal reciprocating engine mechanism as shown in Fig.

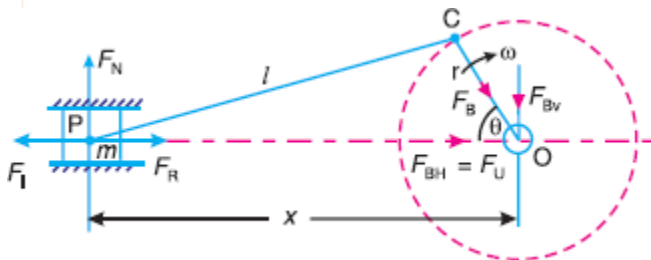

$F_R$  = Force required to accelerate the reciprocating parts,

$F_B$  = Force acting on the crankshaft bearing or main bearing



Since  $F_R$  and  $F_I$  are equal in magnitude but opposite in direction, therefore they balance each other. The horizontal component of  $F_B$  (i.e.  $F_{BH}$ ) acting along the line of reciprocation is also equal and opposite to  $F_I$ . This force  $F_{BH} = F_U$  is an unbalanced force or shaking force and required to be properly balance.

The force on the sides of the cylinder walls ( $F_N$ ) and the vertical component of  $F_B$  (i.e.  $F_{BV}$ ) are equal and opposite and thus form a shaking couple of magnitude  $F_N \times x$  or  $F_{BV} \times x$ .

From above we see that the effect of the reciprocating parts is to produce a shaking force and a shaking couple. Since the shaking force and a shaking couple vary in magnitude and direction during the engine cycle, therefore they cause very objectionable vibrations.

Thus the purpose of balancing the reciprocating masses is to eliminate the shaking force and a shaking couple. In most of the mechanisms, we can reduce the shaking force and a shaking couple by adding appropriate balancing mass, but it is usually not practical to eliminate them completely. In other words, the reciprocating masses are only partially balanced.

### Balancing of Reciprocating Masses

The various forces acting on the reciprocating parts of an engine. The resultant of all the forces acting on the body of the engine due to inertia forces only is known as **unbalanced force** or **shaking force**.

will be will be

Thus if the resultant of all the forces due to inertia effects is zero, then there no unbalanced force, but even then an unbalanced couple or shaking couple present Consider a horizontal reciprocating engine mechanism as shown inFig.

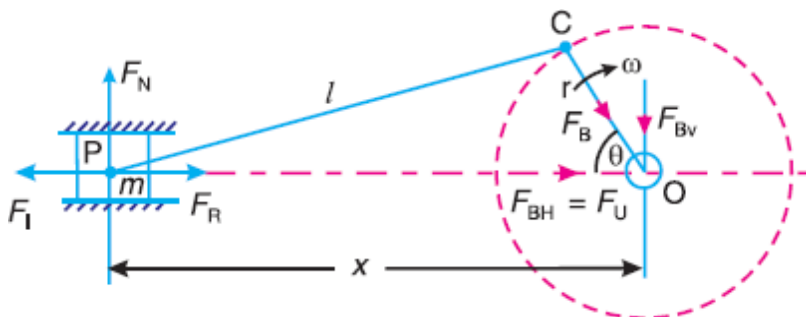

Let  $F_R$  = Force required to accelerate the reciprocating parts,

$F_B$  = Force acting on the crankshaft bearing or main bearing.

Since  $F_R$  and  $F_I$  are equal in magnitude but opposite in direction, therefore they balance each other. The horizontal component of  $F_B$  (i.e.  $F_{BH}$ ) acting along the line of reciprocation is also equal and opposite to  $F_I$ . This force  $F_{BH} = F_U$  is an unbalanced force or shaking force and required to be properly balanced.

The force on the sides of the cylinder walls ( $F_N$ ) and the vertical component of  $F_B$  (i.e.  $F_{BV}$ ) are equal and opposite and thus form a shaking couple of magnitude  $F_N \times x$  or  $F_{BV} \times x$ .



From above we see that the effect of the reciprocating parts is to produce a shaking force and a shaking couple. Since the shaking force and a shaking couple vary in magnitude and direction during the engine cycle, therefore they cause very objectionable vibrations.

Thus the purpose of balancing the reciprocating masses is to eliminate the shaking force and a shaking couple. In most of the mechanisms, we can reduce the shaking force and a shaking couple by adding appropriate balancing mass, but it is usually not practical to eliminate them completely. In other words, the reciprocating masses are only partially balanced.

### Primary and Secondary Unbalanced Forces of Reciprocating Masses

Consider a reciprocating engine mechanism as shown in Fig. Let  $m$  = Mass of the reciprocating parts,

$l$  = Length of the connecting rod  $PC$ ,  $r$  = Radius of the crank  $OC$ ,

$\theta$  = Angle of inclination of the crank with the line of stroke  $PO$ ,  $\omega$  = Angular speed of the crank,

$n$  = Ratio of length of the connecting rod to the crank radius =  $l / r$ .

$$a_R = \omega^2 \cdot r \left( \cos \theta + \frac{\cos 2\theta}{n} \right)$$

Inertia force due to reciprocating parts or force required to accelerate the reciprocating parts.

$$F_I = F_R = \text{Mass} \times \text{acceleration} = m \cdot \omega^2 \cdot r \left( \cos \theta + \frac{\cos 2\theta}{n} \right)$$

We have discussed in the previous article that the horizontal component of the force exerted on the crank shaft bearing (*i.e.* FBH) is equal and opposite to inertia force ( $F_I$ ). This force is an unbalanced one and is denoted by  $F_U$ .

Unbalanced force,

□

$$F_U = m \cdot \omega^2 \cdot r \left( \cos \theta + \frac{\cos 2\theta}{n} \right) = m \cdot \omega^2 \cdot r \cos \theta + m \cdot \omega^2 \cdot r \times \frac{\cos 2\theta}{n} = F_P + F_S$$

The expression  $(m \cdot \omega^2 \cdot r \cos \theta)$  is known as *primary unbalanced force* and  $\left( m \cdot \omega^2 \cdot r \times \frac{\cos 2\theta}{n} \right)$  is called *secondary unbalanced force*.

$\therefore$  Primary unbalanced force,  $F_P = m \cdot \omega^2 \cdot r \cos \theta$

and secondary unbalanced force,  $F_S = m \cdot \omega^2 \cdot r \times \frac{\cos 2\theta}{n}$



## Partial Balancing of Unbalanced Primary Force in a Reciprocating Engine

$$(m \cdot \omega^2 \cdot r \cos \theta)$$

The primary unbalanced force may be considered as the component of the centrifugal force produced by a rotating mass  $m$  placed at the crank radius  $r$ , as shown in Fig.

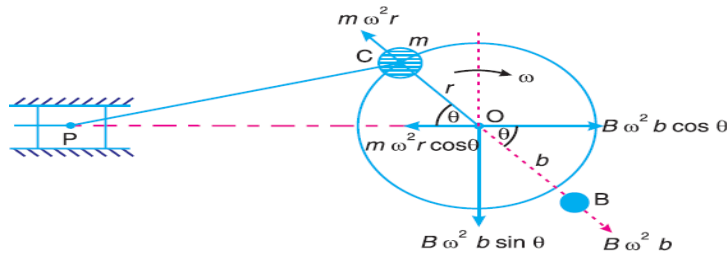

The primary force acts from  $O$  to  $P$  along the line of stroke. Hence, balancing of primary force is considered as equivalent to the balancing of mass  $m$  rotating at the crank radius  $r$ . This is balanced by having a mass  $B$  at a radius  $b$ , placed diametrically opposite to the crank pin  $C$ .

We know that centrifugal force due to mass  $B$ ,

$$= B \cdot \omega^2 \cdot b$$

Horizontal component of this force acting in opposite direction of primary force

$$= B \cdot \omega^2 \cdot b \cos \theta$$

The primary force is balanced, if

$$B \cdot \omega^2 \cdot b \cos \theta = m \cdot \omega^2 \cdot r \cos \theta \quad \text{or} \quad B \cdot b = m \cdot r$$

A little consideration will show, that the primary force is completely balanced if

$B \cdot b = m \cdot r$ , but the centrifugal force produced due to the revolving mass  $B$ , has also a vertical component (perpendicular to the line of stroke) of magnitude  $B \cdot \omega^2 \cdot b \sin \theta$ . This force remains unbalanced

The maximum value of this force is equal to  $B \cdot \omega^2 \cdot b$  when  $\theta$  is  $90^\circ$  and  $270^\circ$ , which is same as the maximum value of the primary force  $m \cdot \omega^2 \cdot r$

let a fraction ' $c$ ' of the reciprocating masses is balanced, such that  $c \cdot m \cdot r = B \cdot b$



∴ Unbalanced force along the line of stroke

$$\begin{aligned}
 &= m \cdot \omega^2 \cdot r \cos \theta - B \cdot \omega^2 \cdot b \cos \theta \\
 &= m \cdot \omega^2 \cdot r \cos \theta - c \cdot m \cdot \omega^2 \cdot r \cos \theta \quad \dots (\because B \cdot b = c \cdot m \cdot r) \\
 &= (1 - c) m \cdot \omega^2 \cdot r \cos \theta
 \end{aligned}$$

and unbalanced force along the perpendicular to the line of stroke

$$= B \cdot \omega^2 \cdot b \sin \theta = c \cdot m \cdot \omega^2 \cdot r \sin \theta$$

∴ Resultant unbalanced force at any instant

$$\begin{aligned}
 &= \sqrt{[(1 - c) m \cdot \omega^2 \cdot r \cos \theta]^2 + [c \cdot m \cdot \omega^2 \cdot r \sin \theta]^2} \\
 &= m \cdot \omega^2 \cdot r \sqrt{(1 - c)^2 \cos^2 \theta + c^2 \sin^2 \theta}
 \end{aligned}$$

### Partial Balancing of Locomotives

The locomotives, usually, have two cylinders with cranks placed at right angles to each other in order to have uniformity in turning moment diagram. The two cylinder locomotives may be classified as:

Inside cylinder locomotives

Outside cylinder locomotives.

In the **inside cylinder locomotives**, the two cylinders are placed in between the planes of two driving wheels as shown in Fig(a) ; whereas in the **outside cylinder locomotives**, the two cylinders are placed outside the driving wheels, one on each side of the driving wheel, as shown in

Fig(b). The locomotives may be

Single or uncoupled locomotives

### Coupled locomotives

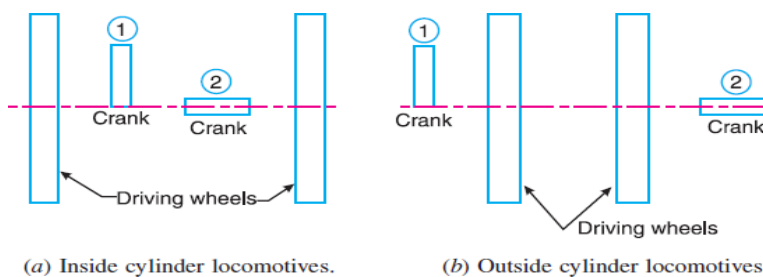

A **single** or **uncoupled locomotive** is one, in which the effort is transmitted to one pair of the wheels only; whereas in **coupled locomotives**, the driving wheels are connected to the leading and trailing wheel by an outside coupling rod.

Effect of Partial Balancing of Reciprocating Parts of Two Cylinder Locomotives



We have discussed in the previous article that the reciprocating parts are only partially balanced. Due to this partial balancing of the reciprocating parts, there is an unbalanced primary force along the line of stroke and also an unbalanced primary force perpendicular to the line of stroke. The effect of an unbalanced primary force along the line of stroke is to produce;

Variation interactive force along the line of stroke Swaying couple.

The effect of an unbalanced primary force perpendicular to the line of stroke is to produce variation in pressure on the rails, which results in hammering action on the rails. The maximum magnitude of the unbalanced force along the perpendicular to the line of stroke is known as a **hammer blow**. We shall now discuss the effects of an unbalanced primary force in the following articles.

Variation of Tractive Force

The resultant unbalanced force due to the two cylinders, along the line of stroke, is known as **tractive force**. Let the crank for the first cylinder be inclined at an angle  $\theta$  with the line of stroke, as shown in Fig. Since the crank for the second cylinder is at right angle to the first crank, therefore the angle of inclination for the second crank will be  $(90^\circ + \theta)$ .

Let  $m$  = Mass of the reciprocating parts per cylinder, and

$c$  = Fraction of the reciprocating parts to be balanced.

We know that unbalanced force along the line of stroke for cylinder 1

$$= 2(1-c)m.\omega^2.r \cos\theta$$

Similarly, unbalanced force along the line of stroke for cylinder 2,

$$= (1-c)m.\omega^2.r \cos(90^\circ + \theta)$$

As per definition, the tractive force,

Definition, the tractive force,

$FT$  = Resultant unbalanced force along the line of stroke

$$= (1-c)m.\omega^2.r \cos\theta + (1-c)m.\omega^2.r \cos(90^\circ + \theta) = (1-c)m.\omega^2.r(\cos\theta - \sin\theta)$$

The tractive force is maximum or minimum when  $(\cos\theta - \sin\theta)$  is maximum or minimum. For  $(\cos\theta - \sin\theta)$  to be maximum or minimum,

$$\frac{d}{d\theta}(\cos\theta - \sin\theta) = 0 \quad \text{or} \quad -\sin\theta - \cos\theta = 0 \quad \text{or} \quad -\sin\theta = \cos\theta$$

$$\therefore \quad \tan\theta = -1 \quad \text{or} \quad \theta = 135^\circ \quad \text{or} \quad 315^\circ$$

Thus, the tractive force is maximum or minimum when  $\theta = 135^\circ$  or  $315^\circ$ . Maximum and minimum value of the tractive force or the variation in tractive force

$$= \pm(1-c)m.\omega^2.r(\cos 135^\circ - \sin 135^\circ) = \pm\sqrt{2}(1-c)m.\omega^2.r$$

Balancing of Primary Forces of Multi-cylinder In-line Engines

The multi-cylinder engines with the cylinder centrelines in the same plane and on the same side of the centreline of the crankshaft are known as **In-line engines**. The following two conditions must be satisfied in order to give the primary balance of the reciprocating parts of a multi cylinder engine:



The algebraic sum of the primary forces must be equal to zero. In other words, the primary force polygon must close

The algebraic sum of the couples about any point in the plane of the primary forces must be equal to zero. In other words, the primary couple polygon must close.

We have already discussed, that the primary unbalanced force due to the reciprocating masses is equal to the component, parallel to the line

of stroke, of the centrifugal force produced by the equal mass placed at the crankpin and revolving with it. Therefore, in order to give the primary balance of the reciprocating parts of a multi-cylinder engine, it is convenient to imagine the reciprocating masses to be transferred to their respective crank pins and to treat the problem as one of revolving masses.

#### Balancing of Secondary Forces of Multi-cylinder In-line Engines

When the connecting rod is not too long (*i.e.* when the obliquity of the connecting rod is considered), then the secondary disturbing force due to the reciprocating mass arises.

$$F_s = m \cdot \omega^2 \cdot r \times \frac{\cos 2\theta}{n}$$

This expression may be written as

$$F_s = m \cdot (2\omega)^2 \times \frac{r}{4n} \times \cos 2\theta$$

As in case of primary forces, the secondary forces may be considered to be equivalent to the component, parallel to the line of stroke, of the centrifugal force produced by an equal mass placed at the imaginary crank of length  $r / 4n$  and revolving at twice the speed of the actual crank (*i.e.*  $2\omega$ ) as shown in Fig.

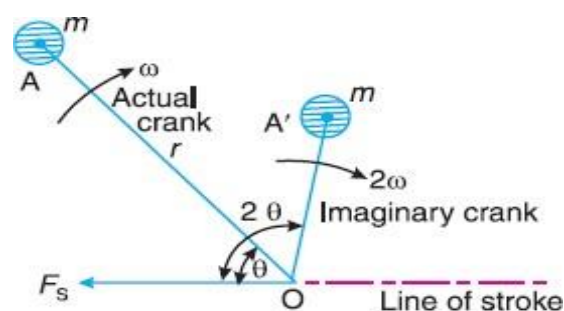

Thus, in multi-cylinder in-line engines, each imaginary secondary crank with a mass attached to the crankpin is inclined to the line of stroke at twice the angle of the actual crank. The values of the secondary forces and couples may be obtained by considering the revolving mass. This is done in the



similar way as discussed for primary forces. The following two conditions must be satisfied in order to give a complete secondary balance of an engine:

The algebraic sum of the secondary forces must be equal to zero. In other words, the secondary force polygon must close, and The algebraic sum of the couples about any point in the plane of the secondary forces must be equal to zero. In other words, the secondary couple polygon must close.

**Example1.** A four cylinder vertical engine has cranks 150 mm long. The planes of rotation of the first, second and fourth cranks are 400 mm, 200 mm and 200 mm respectively from the third crank and their reciprocating masses are 50 kg, 60 kg and 50 kg respectively. Find the mass of the reciprocating parts for the third cylinder and the relative angular positions of the cranks in order that the engine may be in complete primary balance.

**Solution.** Given  $r_1 = r_2 = r_3 = r_4 = 150 \text{ mm} = 0.15 \text{ m}$  ;  $m_1 = 50 \text{ kg}$  ;  $m_2 = 60 \text{ kg}$  ;  $m_4 = 50 \text{ kg}$

in order to give the primary balance of the reciprocating parts of a multi-cylinder engine, the problem may be treated as that of revolving masses with the reciprocating masses transferred to their respective crank pins.

The position of planes is shown in Fig(a). Assuming the plane of third cylinder as the reference plane, the data may be tabulated as given in Table.

Plane (1)	Mass (m) kg (2)	Radius (r) m (3)	Cent. force $\div \omega^2$ (m.r) kg-m (4)	Distance from plane 3(l) m (5)	Couple $\div \omega^2$ (m.r.l) kg-m <sup>2</sup> (6)
1	50	0.15	7.5	- 0.4	- 3
2	60	0.15	9	- 0.2	- 1.8
3(R.P.)	$m_3$	0.15	$0.15m_3$	0	0
4	50	0.15	7.5	0.2	1.5

First of all, the angular position of cranks 2 and 4 are obtained by drawing the couple polygon from the data given in Table (column 6). Assume the position of crank 1 in the horizontal direction as shown in Fig (b),

The couple polygon, as shown in Fig(c), is drawn as discussed below:

Draw vector  $o' a'$  in the horizontal direction (i.e. parallel to  $O_1$ ) and equal to  $- 3 \text{ kg-m}^2$ , to some suitable scale.

From point  $o'$  and  $a'$ , draw vectors  $o' b'$  and  $a' b'$  equal to  $- 1.8 \text{ kg-m}^2$  and  $1.5 \text{ kg-m}^2$  respectively. These vectors intersect at  $b'$ .



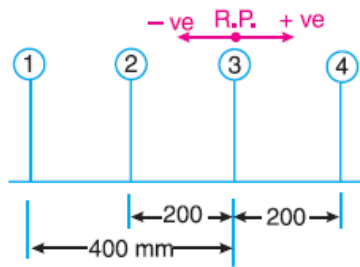

(a) Position of planes.

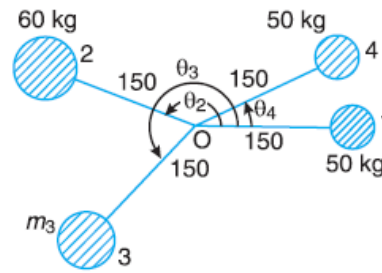

(b) Angular position of cranks.

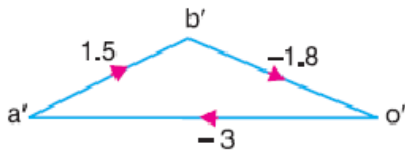

(c) Couple polygon.

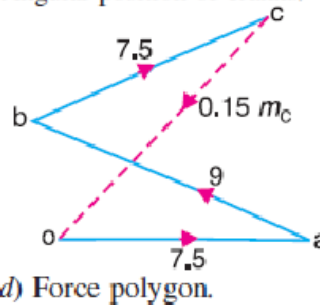

(d) Force polygon.

Now in Fig. 22.17 (b), draw  $O_2$  parallel to vector  $o' b'$  and  $O_4$  parallel to vector  $a' b'$ . By measurement, we find that the angular position of crank 2 from crank 1 in the anticlockwise directions  $\theta_2 = 160^\circ$  and the angular position of crank 4 from crank 1 in the anticlockwise direction is  $\theta_4 = 26^\circ$ . In order to find the mass of the third cylinder ( $m_3$ ) and its angular position, draw the force polygon, to some suitable scale, as shown in Fig (d), from the data given in Table (column 4). Since the closing side of the force polygon (vector  $co$ ) is proportional to  $0.15 m_3$ , therefore by measurement,  $0.15 m_3 = 9 \text{ kg-m}$  or  $m_3 = 60 \text{ kg}$ . Now draw  $O_3$  in Fig 22.17 (b), parallel to vector  $co$ . By measurement, we find that the angular position of crank 3 from crank 1 in the anticlockwise direction is  $\theta_3 = 227^\circ$ .

### Balancing of Radial Engines (Direct and Reverse Cranks Method)

The method of direct and reverse cranks is used in balancing of radial or V-engines, in which the connecting rods are connected to a common crank. Since the plane of rotation of the various cranks (in radial or V-engines) is same, therefore there is no unbalanced primary or secondary couple.

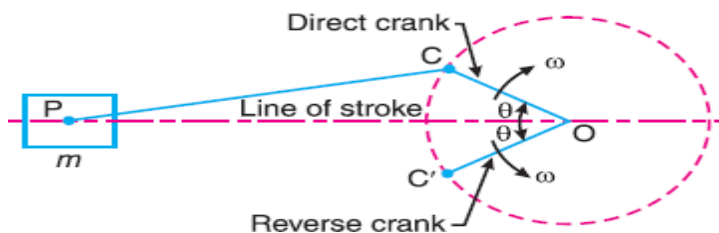

Consider a reciprocating engine mechanism as shown in Fig. 22.27. Let the crank  $OC$  (known as the direct crank) rotates uniformly at  $\omega$  radians per second in a clockwise direction. Let at any instant the crank makes an angle  $\theta$  with the line of stroke  $OP$ . The indirect or reverse crank  $OC'$  is the image of the direct crank  $OC$ , when seen through the mirror placed at the line of stroke. A little consideration will show that



when the direct crank revolves in a clockwise direction, the reverse crank will revolve in the anticlockwise direction. We shall now discuss the primary and secondary forces due to the mass ( $m$ ) of the reciprocating parts at  $P$ .

### Considering the primary forces

We have already discussed that primary force is  $2 m \cdot \omega^2 \cdot r \cos \theta$ . This force is equal to the component of the centrifugal force along the line of stroke, produced by a mass ( $m$ ) placed at the crank pin  $C$ . Now let us suppose that the mass ( $m$ ) of the reciprocating parts is divided into two parts, each equal to  $m / 2$ .

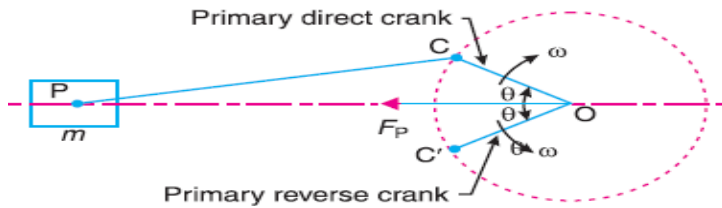

It is assumed that  $m / 2$  is fixed at the **direct crank** (termed as **primary direct crank**) pin  $C$  and  $m / 2$  at the **reverse crank** (termed as **primary reverse crank**) pin  $C'$ , as shown in Fig. We know that the centrifugal force acting on the primary direct and reverse crank

$$= \frac{m}{2} \times \omega^2 \cdot r$$

∴ Component of the centrifugal force acting on the primary direct crank

$$= \frac{m}{2} \times \omega^2 \cdot r \cos \theta \quad \dots \text{ (in the direction from } O \text{ to } P \text{)}$$

and, the component of the centrifugal force acting on the primary reverse crank

$$= \frac{m}{2} \times \omega^2 \cdot r \cos \theta \quad \dots \text{ (in the direction from } O \text{ to } P \text{)}$$

∴ Total component of the centrifugal force along the line of stroke

$$= 2 \times \frac{m}{2} \times \omega^2 \cdot r \cos \theta = m \cdot \omega^2 \cdot r \cos \theta = \text{Primary force, } F_p$$

Hence, for primary effects the mass  $m$  of the reciprocating parts at  $P$  may be replaced by two masses at  $C$  and  $C'$  each of magnitude  $m/2$ .

### Considering secondary forces



We know that the secondary force

$$= m(2\omega)^2 \frac{r}{4n} \times \cos 2\theta = m \cdot \omega^2 r \cdot \frac{\cos 2\theta}{n}$$

In the similar way as discussed above, it will be seen that for the secondary effects, the mass ( $m$ ) of the reciprocating parts may be replaced by two masses (each  $m/2$ ) placed at  $D$  and  $D'$  such that  $OD = OD' = r/4n$ . The crank  $OD$  is the secondary direct crank and rotates at  $2\pi$  rad/s in the clockwise direction, while the crank  $OD'$  is the secondary reverse crank and rotates at  $2\pi$  rad/s in the anticlockwise direction as shown in Fig.

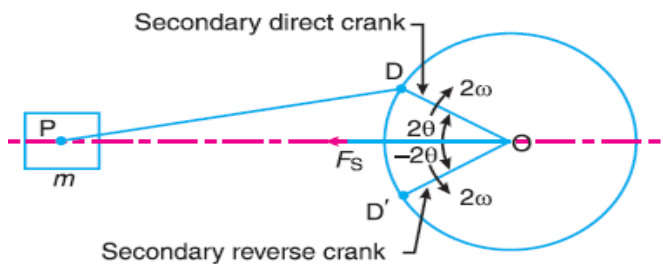

### PROBLEMS

**Example 1.** The three cylinders of an air compressor have their axes  $120^\circ$  to one another, and their connecting rods are coupled to a single crank. The stroke is 100 mm and the length of each connecting rod is 150 mm. The mass of the reciprocating parts per cylinder is 1.5 kg. Find the maximum primary and secondary forces acting on the frame of the compressor when running at 3000 r.p.m. Describe clearly a method by which such forces may be balanced.

**Solution.** Given :  $L = 100$  mm or  $r = L / 2 = 50$  mm = 0.05 m ;  $l = 150$  mm = 0.15 m ;  $m = 1.5$  kg ;  $N = 3000$  r.p.m. or  $\omega = 2\pi \times 3000/60 = 314.2$  rad/s

The position of three cylinders is shown in Fig. Let the common crank be along the inner dead centre of

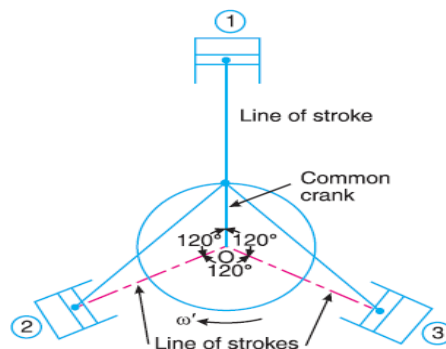

cylinder 1. Since common crank rotates clockwise, therefore  $\theta$  is positive when measured clockwise.

### Maximum primary force acting on the frame of the compressor

The primary direct and reverse crank positions as shown in Fig.(a) and (b), are obtained as discussed below :

Since  $\theta = 0^\circ$  for cylinder 1, therefore both the primary direct and reverse cranks will coincide with the common crank. Since  $\theta = \pm 120^\circ$  for cylinder 2, therefore the primary direct crank is  $120^\circ$  clockwise and the primary reverse crank is  $120^\circ$  anti-clockwise from the line of stroke of cylinder 2.

Since  $\theta = \pm 240^\circ$  for cylinder 3, therefore the primary direct crank is  $240^\circ$  clockwise and the primary reverse crank is  $240^\circ$  anti-clockwise from the line of stroke of cylinder 3. From Fig.(b), we see that the primary reverse cranks form a balanced system. Therefore there is no unbalanced primary force due to the reverse cranks. From Fig (a), we see that the resultant primary force is

$$\therefore \text{Maximum primary force} = \frac{3m}{2} \times \omega^2 \cdot r = \frac{3 \times 1.5}{2} (314.2)^2 0.05 = 11\,106 \text{ N} = 11.106 \text{ kN}$$

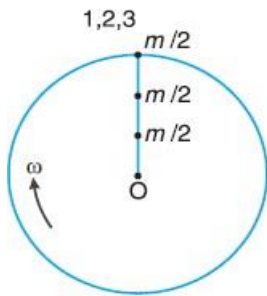

(a) Direct primary cranks.

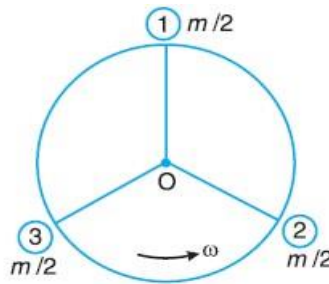

(b) Reverse primary cranks.

equivalent to the centrifugal force of a mass  $3 m/2$  attached to the end of the crank.

maximum primary force may be balanced by a mass attached diametrically opposite to the crank pin and

$$B_1 \cdot b_1 = \frac{3m}{2} \times r = \frac{3 \times 1.5}{2} \times 0.05 = 0.1125 \text{ N-m}$$

rotating with the crank, of magnitude  $B_1$  at radius  $b_1$  such that

### Maximum secondary force acting on the frame of the compressor

The secondary direct and reverse crank positions as shown in Fig (a) and (b), are obtained as discussed below:

Since  $\theta = 0^\circ$  and  $2\theta = 0^\circ$  for cylinder 1, therefore both the secondary direct and reverse cranks will coincide with the common crank.

Since  $\theta = \pm 120^\circ$  and  $2\theta = \pm 240^\circ$  for cylinder 2, therefore the secondary direct crank is  $240^\circ$  clockwise and the secondary reverse crank is  $240^\circ$  anticlockwise from the line of stroke of cylinder 2.



Since  $\theta = \pm 240^\circ$  and  $2\theta = \pm 480^\circ$ , therefore the secondary direct crank is  $480^\circ$  or  $120^\circ$  clockwise and the secondary reverse crank is  $480^\circ$  or  $120^\circ$  anti-clockwise from the line of stroke of cylinder 3.

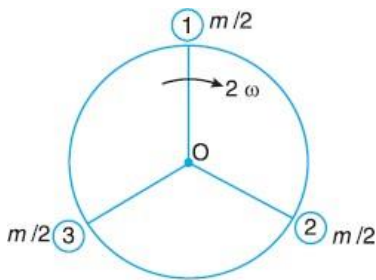

(a) Direct secondary cranks.

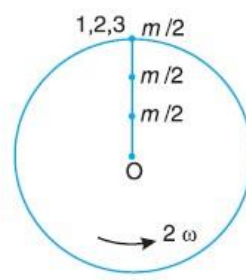

(b) Reverse secondary cranks.

From Fig (a), we see that the secondary direct cranks form a balanced system. Therefore there is no unbalanced secondary force due to the direct cranks. From Fig (b), we see that the resultant secondary force is equivalent to the centrifugal force of a mass  $3m/2$  attached at a crank radius of  $r/4n$  and rotating at a speed of  $2\omega$  rad/s in the opposite direction to the crank.

$\therefore$  Maximum secondary force

$$= \frac{2m}{2} (2\omega)^2 \left( \frac{r}{4n} \right) = \frac{3 \times 1.5}{2} (2 \times 314.2)^2 \left[ \frac{0.05}{4 \times 0.15 / 0.05} \right] \text{N}$$

$\dots (\because n = l/r)$

$$= 3702 \text{ N Ans.}$$

This maximum secondary force may be balanced by a mass  $B_2$  at radius  $b_2$ , attached diametrically opposite to the crankpin, and rotating anti-clockwise at twice the crank speed, such that

$$B_2 b_2 = \frac{3m}{2} \times \frac{r}{4n} = \frac{3 \times 1.5}{2} \times \frac{0.05}{4 \times 0.15 / 0.05} = 0.009375 \text{ N-m}$$

Balancing of V-engines

Consider a symmetrical two cylinder V-engine as shown in Fig. 22.33,

The common crank  $OC$  is driven by two connecting rods  $PC$  and  $QC$ . The lines of stroke  $OP$  and  $OQ$  are inclined to the vertical  $OY$ , at an angle  $\alpha$  as shown in Fig.

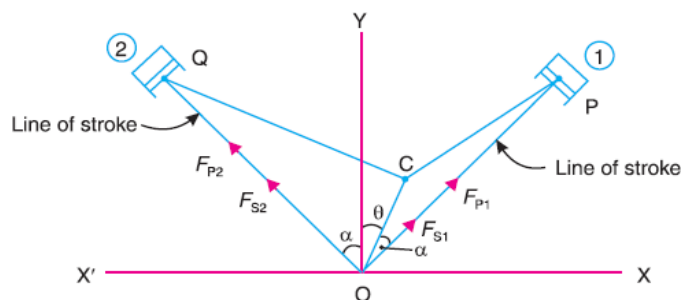

that inertia force due to reciprocating parts of cylinder 1, along the line of stroke

the inertia force due to reciprocating parts of cylinder 2, along the line of stroke

$$= m.\omega^2.r \left[ \cos(\alpha - \theta) + \frac{\cos 2(\alpha + \theta)}{n} \right]$$

The balancing of V-engines is only considered for primary and secondary forces\* as discussed below :

### Considering primary forces

We know that primary force acting along the line of stroke of cylinder 1,  $F_{P1} = m.\omega^2.r \cos(\alpha - \theta)$

Component of  $F_{P1}$  along the vertical line  $OY$

$$= F_{P1} \cos\alpha = m.\omega^2.r.\cos(\alpha - \theta)\cos\alpha \quad \text{(i)}$$

and component of  $F_{P1}$  along the horizontal line  $OX$

$$= F_{P1} \sin\alpha = m.\omega^2.r.\sin(\alpha - \theta)\sin\alpha \quad \text{(ii)}$$

Similarly, primary force acting along the line of stroke of cylinder 2,  $F_{P2} = m.\omega^2.r \cos(\alpha + \theta)$

Component of  $F_{P2}$  along the vertical line  $OY$

$$F_{P2}\cos\alpha = m.\omega^2.r.\cos(\alpha + \theta)\cos\alpha \quad \text{(iii)}$$

and component of  $F_{P2}$  along the horizontal line  $OX'$

$$\begin{aligned} F_{PV} &= \text{(i)} + \text{(iii)} = m.\omega^2.r \cos\alpha [\cos(\alpha - \theta) + \cos(\alpha + \theta)] \\ &= m.\omega^2.r \cos\alpha \times 2 \cos\alpha \cos\theta \\ &\quad \dots [\because \cos(\alpha - \theta) + \cos(\alpha + \theta) = 2 \cos\alpha \cos\theta] \\ &= 2 m.\omega^2.r \cos^2\alpha \cos\theta \\ F_{P2} \sin\alpha &= m.\omega^2.r.\sin(\alpha + \theta)\sin\alpha \quad \text{(iv)} \end{aligned}$$

Total component of primary force along the vertical line  $OY$

total component of primary force along the horizontal line  $OX$



$$\begin{aligned}
 F_{PH} &= (ii) - (iv) = m\omega^2.r \sin \alpha [\cos(\alpha - \theta) - \cos(\alpha + \theta)] \\
 &= m\omega^2.r \sin \alpha \times 2 \sin \alpha \sin \theta \\
 &\quad \dots [\because \cos(\alpha - \theta) - \cos(\alpha + \theta) = 2 \sin \alpha \sin \theta] \\
 &= 2m\omega^2.r \sin^2 \alpha \sin \theta
 \end{aligned}$$

∴ Resultant primary force,

$$\begin{aligned}
 F_P &= \sqrt{(F_{PV})^2 + (F_{PH})^2} \\
 &= 2m\omega^2.r \sqrt{(\cos^2 \alpha \cos^2 \theta) + (\sin^2 \alpha \sin^2 \theta)} \quad \dots (v)
 \end{aligned}$$

Considering secondary forces

We know that secondary force acting along the line of stroke of cylinder 1,

$$F_{S1} = m\omega^2.r \times \frac{\cos 2(\alpha - \theta)}{n}$$

∴ Component of  $F_{S1}$  along the vertical line  $OY$

$$= F_{S1} \cos \alpha = m\omega^2.r \times \frac{\cos 2(\alpha - \theta)}{n} \times \cos \alpha \quad \dots (ix)$$

Component of  $F_{S1}$  along the horizontal line  $OX$

$$= F_{S1} \sin \alpha = m\omega^2.r \times \frac{\cos 2(\alpha - \theta)}{n} \times \sin \alpha \quad \dots (x)$$

Similarly, secondary force acting along the line of stroke of cylinder 2,

$$F_{S2} = m\omega^2.r \times \frac{\cos 2(\alpha + \theta)}{n}$$

Component of  $F_{S2}$  along the vertical line  $OY$

$$= F_{S2} \cos \alpha = m\omega^2.r \times \frac{\cos 2(\alpha + \theta)}{n} \times \cos \alpha \quad \dots (xi)$$

$$= F_{S2} \sin \alpha = m\omega^2.r \times \frac{\cos 2(\alpha + \theta)}{n} \times \sin \alpha \quad \dots (xii)$$

Component of  $F_{S2}$  along the horizontal line  $OX'$

Total component of secondary force along the vertical line  $OY$ ,

$$\begin{aligned}
 F_{SV} &= (ix) + (xi) = \frac{m}{n} \times \omega^2.r \cos \alpha [\cos 2(\alpha - \theta) + \cos 2(\alpha + \theta)] \\
 &= \frac{m}{n} \times \omega^2.r \cos \alpha \times 2 \cos 2\alpha \cos 2\theta = \frac{2m}{n} \times \omega^2.r \cos \alpha \cos 2\alpha \cos 2\theta
 \end{aligned}$$



$$\begin{aligned}
 F_{SH} &= (x) - (xii) = \frac{m}{n} \times \omega^2 \cdot r \sin \alpha [\cos 2(\alpha - \theta) - \cos 2(\alpha + \theta)] \\
 &= \frac{m}{n} \times \omega^2 \cdot r \sin \alpha \times 2 \sin 2\alpha \cdot \sin 2\theta \\
 &= \frac{2m}{n} \times \omega^2 \cdot r \sin \alpha \cdot \sin 2\alpha \cdot \sin 2\theta
 \end{aligned}$$

total component of secondary force along the horizontal line OX,

#### PROBLEMS

Resultant secondary force,

$$\begin{aligned}
 F_S &= \sqrt{(F_{SV})^2 + (F_{SH})^2} \\
 &= \frac{2m}{n} \times \omega^2 \cdot r \sqrt{(\cos \alpha \cdot \cos 2\alpha \cdot \cos 2\theta)^2 + (\sin \alpha \cdot \sin 2\alpha \cdot \sin 2\theta)^2}
 \end{aligned}$$

**Example 1.** A vee-twin engine has the cylinder axes at right angles and the connecting rods operate a common crank. The reciprocating mass per cylinder is 11.5 kg and the crank radius is 75 mm. The length of the connecting rod is 0.3 m. Show that the engine may be balanced for primary forces by means of a revolving balancemass.

If the engine speed is 500 r.p.m. What is the value of maximum resultant secondary force?

**Solution.** Given :  $2\theta = 90^\circ$  or  $\alpha = 45^\circ$  ;  $m = 11.5$  kg ;  $r = 75$  mm = 0.075 m ;  $l = 0.3$  m ;  $N = 500$  r.p.m. or  $\omega = 2\pi \times 500 / 60 = 52.37$  rad/s

We know that resultant primary force,

$$\begin{aligned}
 F_P &= 2m \cdot \omega^2 \cdot r \sqrt{(\cos^2 \alpha \cos \theta)^2 + (\sin^2 \alpha \sin \theta)^2} \\
 &= 2m \cdot \omega^2 \cdot r \sqrt{(\cos^2 45^\circ \cos \theta)^2 + (\sin^2 45^\circ \sin \theta)^2} \\
 &= 2m \cdot \omega^2 \cdot r \sqrt{\left[\frac{\cos \theta}{2}\right]^2 + \left[\frac{\sin \theta}{2}\right]^2} = m \cdot \omega^2 \cdot r
 \end{aligned}$$

Since the resultant primary force  $m \cdot \omega^2 \cdot r$  is the centrifugal force of a mass  $m$  at the crank radius  $r$  when rotating at  $\omega$  rad / s, therefore, the engine may be balanced by a rotating balance mass.

Maximum resultant secondary force

We know that resultant secondary force,

$$F_S = \sqrt{2} \times \frac{m}{n} \times \omega^2 \cdot r \sin 2\theta \quad \dots \text{ ( When } 2\alpha = 90^\circ \text{ )}$$



This is maximum, when  $\sin 2\theta$  is maximum *i.e.* when  $\sin 2\theta = \pm 1$  or  $\theta = 45^\circ$  or  $135^\circ$ . Maximum resultant secondary force,

$$F_{S_{max}} = \sqrt{2} \times \frac{m}{n} \times \omega^2 \cdot r \quad \dots \text{(Substituting } \theta = 45^\circ \text{)}$$

$$= \sqrt{2} \times \frac{11.5}{0.3/0.075} (52.37)^2 0.075 = 836 \text{ N Ans.} \quad \dots (\because n = l/r)$$

## Types of Free Vibrations

The following three types of free vibrations are important from the subject point of view :

1. Longitudinal vibrations, 2. Transverse vibrations, and 3. Torsional vibrations.

Consider a weightless constraint (spring or shaft) whose one end is fixed and the other end carrying a heavy disc, as shown in Fig. This system may execute one of the three above mentioned types of

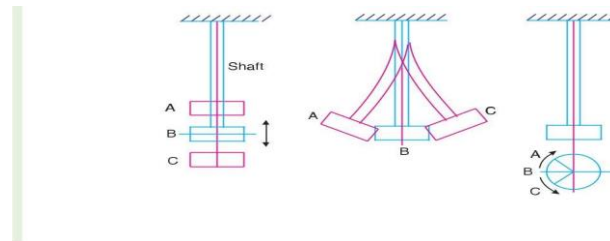

## vibrations

(a) Longitudinal vibrations. (b) Transverse vibrations. (c) Torsional vibrations.

1. **Longitudinal vibrations.** When the particles of the shaft or disc moves parallel to the axis of the shaft, as shown in Fig. (a), then the vibrations are known as **longitudinal vibrations**. In this case, the shaft is elongated and shortened alternately and thus the tensile and compressive stresses are induced alternately in the shaft.

2. **Transverse vibrations.** When the particles of the shaft or disc move approximately perpendicular to the axis of the shaft, as shown in Fig (b), then the vibrations are known as **transverse vibrations**. In this case, the shaft is straight and bent alternately and bending stresses are induced in the shaft.

**Torsional vibrations\***. When the particles of the shaft or disc move in a circle about the axis of the shaft, as shown in Fig. (c), then the vibrations are known as **torsional vibrations**. In this case, the shaft is twisted and untwisted alternately and the torsional shear stresses are induced in these shaft.

## Critical or Whirling Speed of a Shaft

A rotating shaft carries different mountings and accessories in the form of gears, pulleys, etc. When the gears or pulleys are put on the shaft, the centre of gravity of the



Pulley or gear does not coincide with the centerline of the bearings or with the axis of the shaft, when the shaft is stationary. This means that the centre of gravity of the pulley or gear is at a certain distance from the axis of rotation and due to this, the shaft is subjected to centrifugal force.

This force will bent the shaft which will further increase the distance of centre of gravity of the pulley or gear from the axis of rotation. This correspondingly increases the value of centrifugal force, which further increases the distance of centre of gravity from the axis of rotation. This effect is cumulative and ultimately the shaft fails. The bending of shaft not only depends upon the value of eccentricity (distance between centre of gravity of the pulley and the axis of rotation) but also depends upon the speed at which the shaft rotates **The speed at which the shaft runs so that the additional deflection of the shaft from the axis of rotation becomes infinite, is known as *critical or whirlingspeed*.**

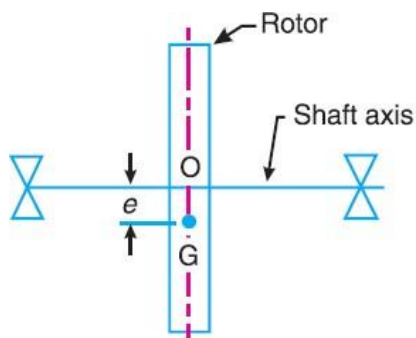

(a) When shaft is stationary.

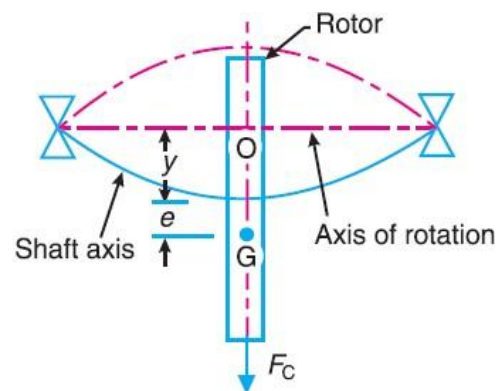

(b) When shaft is rotating.

Consider a shaft of negligible mass carrying a rotor, as shown in Fig.(a). The point O is on the shaft axis and G is the centre of gravity of the rotor. When the shaft is stationary, the centreline of the bearing and the axis of the shaft coincides. Fig.(b) shows the shaft when rotating about the axis of rotation at a uniform speed of  $\omega$  rad/s.

Let  $m$  = Mass of the rotor,

$e$  = Initial distance of centre of gravity of the rotor from the centre line of the bearing or shaft axis, when the shaft is stationary,

$y$  = Additional deflection of centre of gravity of the rotor when the shaft starts rotating at  $\omega$  rad/s, and  $s$  = Stiffness of the shaft *i.e.* the load required per unit deflection of the shaft.

Since the shaft is rotating at  $\omega$  rad/s, therefore centrifugal force acting radially outwards through G

causing the shaft to deflect is given by The shaft behaves like a spring.



$$F_C = m.\omega^2 (y + e)$$

Therefore the force resisting the deflection  $y$ , =  $s.y$  For the equilibrium position

$$m.\omega^2 (y + e) = s.y$$

$$m.\omega^2 .y + m.\omega^2 .e = s.y \quad \text{or} \quad y(s - m.\omega^2) = m.\omega^2 .e$$

$$y = \frac{m.\omega^2 .e}{s - m.\omega^2} = \frac{\omega^2 .e}{s/m - \omega^2}$$

We know that circular frequency,

$$\omega_n = \sqrt{\frac{s}{m}} \quad \text{or} \quad y = \frac{\omega^2 .e}{(\omega_n)^2 - \omega^2}$$

$$\omega_n = \sqrt{\frac{s}{m}} \quad \text{or} \quad y = \frac{\omega^2 .e}{(\omega_n)^2 - \omega^2}$$

A little consideration will show that when  $\omega > \omega_n$ , the value of  $y$  will be negative and the shaft deflects in

$$y = \pm \frac{\omega^2 e}{(\omega_n)^2 - \omega^2} = \frac{\pm e}{\left(\frac{\omega_n}{\omega}\right)^2 - 1} = \frac{\pm e}{\left(\frac{\omega_c}{\omega}\right)^2 - 1}$$

the opposite direction as shown dotted in Fig

We see from the above expression that when  $\omega_n = \omega_c$  the value of  $y$  becomes infinite. Therefore  $\omega_c$  is the **critical or whirling speed**.

$$\omega_c = \omega_n = \sqrt{\frac{s}{m}} = \sqrt{\frac{g}{\delta}} \text{ Hz}$$

If  $N_c$  is the critical or whirling speed in r.p.s., then

$$2\pi N_c = \sqrt{\frac{g}{\delta}} \quad \text{or} \quad N_c = \frac{1}{2\pi} \sqrt{\frac{g}{\delta}} = \frac{0.4985}{\sqrt{\delta}} \text{ r.p.s.}$$

$\delta$  = Static deflection of the shaft in metres.

Hence the critical or whirling speed is the same as the natural frequency of transverse vibration but its unit will be revolutions per second.



## Free Torsional Vibrations of a Single Rotor System

$$f_n = \frac{1}{2} \sqrt{\frac{q}{I}} = \frac{1}{2} \sqrt{\frac{C \cdot J}{l \cdot I}}$$

A shaft is fixed at one end and carrying a rotor at the free end. The natural frequency of torsional vibration.

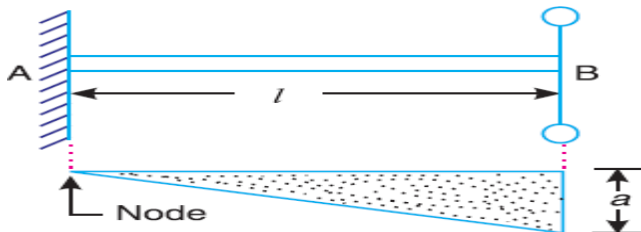

## Free Torsional Vibrations of a Two Rotor System

Consider two rotor systems. It consists of a shaft with two rotors at its ends. In these system torsional vibrations occurs only when the two rotors A and B move in opposite directions. It may be noted that the two rotors must have same frequency. The node lies at Point N. This point can be safely assumed as fixed end of the shaft may be considered as two separate shafts NP and NQ each fixed to one of its ends and carrying rotors at the free end

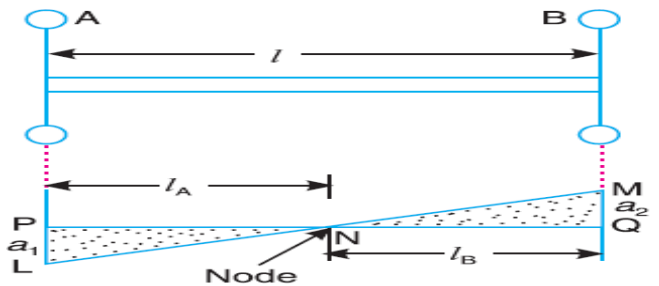

$l$  = Length of the shaft  $l_A$  = Length of the part NP'  $l_B$  = Length of the part NQ

$I_A$  = Mass moment of inertia of rotor A  $I_B$  = Mass moment of inertia of rotor B  $d$  = diameter of the shaft

$J$  = polar moment of inertia of shaft  $C$  = Modulus of rigidity for shaft

then natural frequency for Rotor A

$$f_{nA} = \frac{1}{2} \sqrt{\frac{C \cdot J}{l_A \cdot I_A}}$$



$$f_{nB} = \frac{1}{2} \sqrt{\frac{C.J}{l_B \cdot I_B}}$$

Natural frequency for Rotor ...

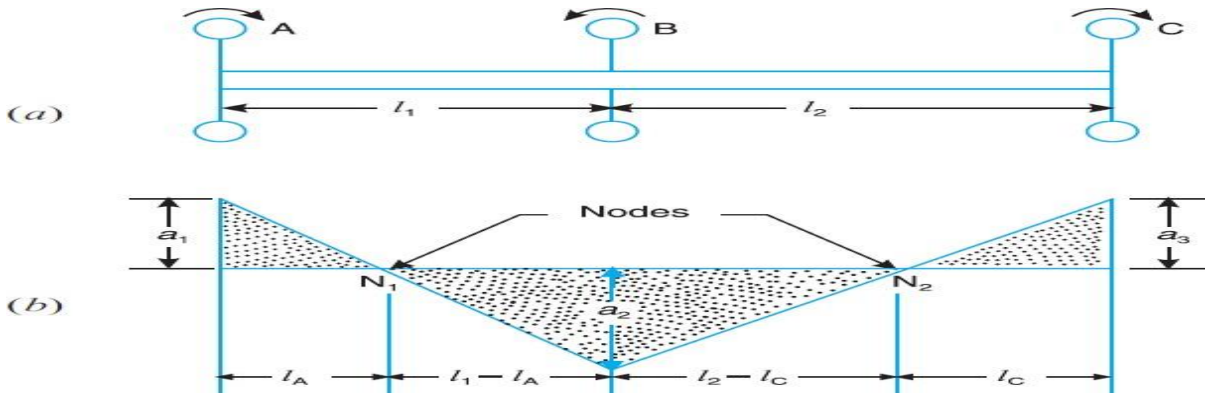

Free Tensional Vibrations of a Three Rotor System

Since  $f_{nA} = f_{nB} = f_{nC}$ ,

$$\frac{1}{2} \sqrt{\frac{C.J}{l_A \cdot I_A}} = \frac{1}{2} \sqrt{\frac{C.J}{l_C \cdot I_C}} \quad \text{or} \quad l_A \cdot I_A = l_C \cdot I_C$$

$$l_A = \frac{l_C \cdot I_C}{I_A}$$

Now equating equations

$$\frac{1}{2} \sqrt{\frac{C.J}{I_B} \frac{1}{l_1} \frac{1}{l_A}} = \frac{1}{2} \sqrt{\frac{C.J}{l_C \cdot I_C}}$$



## INDUSTRIAL APPLICATIONS

# Applications

- **Optics, Photonics and Measuring Technology**
- Image stabilization
- Scanning microscopy
- Auto focus systems
- Interferometry
- Fiber optic alignment & switching
- Fast mirror scanners
- Adaptive and active optics
- Lasertuning
- Mirror positioning
- Holography
- Stimulation of vibrations
- **Disk Drive**
- MR head testing
- Pole tip recession
- Disk spin stands
- Vibration cancellation
- **Microelectronics**
- Nano-metrology
- Wafer and mask positioning
- Critical Dimensions measurement
- Microlithography
- Inspection systems
- Vibration cancellation
- **Precision Mechanics and Mechanical Engineering**
- Vibration cancellation
- Structural deformation
- Out-of-roundness grinding, drilling, turning
- Tool adjustment
- Wear correction
- Needle valve actuation
- Micro pumps
- Linear drives
- Piezo hammers
- Knife edge control in extrusion tools
- Micro engraving systems
- Shock wave generation
- **Life Science, Medicine, Biology**
- Patch-clamp drives
- Gene technology
- Micro manipulation
- Cell penetration
- Micro dispensing devices
- Audiophysiological stimulation
- Shock wave generation



## TUTORIAL QUESTIONS

1. Explain clearly the terms 'static balancing' and 'dynamic balancing'. State the necessary conditions to achieve them. and Discuss how a single revolving mass is balanced by two masses revolving in different planes.
2. Four masses A, B, C and D are attached to a shaft and revolve in the same plane. The masses are 12 kg, 10 kg, 18 kg and 15 kg respectively and their radii of rotations are 40 mm, 50 mm, 60 mm and 30 mm. The angular position of the masses B, C and D are  $60^\circ$ ,  $135^\circ$  and  $270^\circ$  from the mass A. Find the magnitude and position of the balancing mass at a radius of 100 mm.
3. Four masses A, B, C and D revolve at equal radii and are equally spaced along a shaft. The mass B is 7 kg and the radii of C and D make angles of  $90^\circ$  and  $240^\circ$  respectively with the radius of B. Find the magnitude of the masses A, C and D and the angular position of A so that the system may be completely balanced.
4. The cranks and connecting rods of a 4-cylinder in-line engine running at 1800 r.p.m. are 60 mm and 240 mm each respectively and the cylinders are spaced 150 mm apart. If the cylinders are numbered 1 to 4 in sequence from one end, the cranks appear at intervals of  $90^\circ$  in an end view in the order 1-4-2-3. The reciprocating mass corresponding to each cylinder is 1.5 kg. Determine : 1. Unbalanced primary and secondary forces, if any, and 2. Unbalanced primary and secondary couples with reference to central plane of the engine.
5. A cantilever shaft 50 mm diameter and 300 mm long has a disc of mass 100 kg at its free end. The Young's modulus for the shaft material is  $200 \text{ GN/m}^2$  . Determine the frequency of longitudinal and transverse vibrations of the shaft.

## ASSIGNMENT QUESTIONS

1. Explain the method of balancing of different masses revolving in the same plane.
2. A, B, C and D are four masses carried by a rotating shaft at radii 100, 125, 200 and 150 mm respectively. The planes in which the masses revolve are spaced 600 mm apart and the mass of B, C and D are 10 kg, 5 kg, and 4 kg respectively. Find the required mass A and the relative angular settings of the four masses so that the shaft shall be in complete balance.

3.

**Example 21.3.** Four masses A, B, C and D as shown below are to be completely balanced.

	A	B	C	D
Mass (kg)	—	30	50	40
Radius (mm)	180	240	120	150

*The planes containing masses B and C are 300 mm apart. The angle between planes containing B and C is  $90^\circ$ . B and C make angles of  $210^\circ$  and  $120^\circ$  respectively with D in the same sense. Find :*

1. The magnitude and the angular position of mass A ; and
2. The position of planes A and D.

4. The three cranks of a three cylinder locomotive are all on the same axle and are set at  $120^\circ$ . The pitch of the cylinders is 1 metre and the stroke of each piston is 0.6 m. The reciprocating masses are 300 kg for inside cylinder and 260 kg for each outside cylinder and the planes of rotation of the balance masses are 0.8 m from the inside crank. If 40% of the reciprocating parts are to be balanced, find : 1. the magnitude and the position of the balancing masses required at a radius of 0.6 m ; and 2. the hammer blow per wheel when the axle makes 6 r.p.s.
5. The following data refer to two cylinder locomotive with cranks at  $90^\circ$  : Reciprocating mass per cylinder = 300 kg ; Crank radius = 0.3 m ; Driving wheel diameter = 1.8 m ; Distance between cylinder centre lines = 0.65 m ; Distance between the driving wheel central planes = 1.55 m. Determine : 1. the fraction of the reciprocating masses to be balanced, if the hammer blow is not to exceed 46 kN at 96.5 km. p.h. ; 2. the variation in tractive effort ; and 3. the maximum swaying couple.
6. A four cylinder vertical engine has cranks 150 mm long. The planes of rotation of the first, second and fourth cranks are 400 mm, 200 mm and 200 mm respectively from the third crank and their reciprocating masses are 50 kg, 60 kg and 50 kg respectively. Find the mass of the reciprocating parts for the third cylinder and the relative angular positions of the cranks in order that the engine may be in complete primary balance.
7. A shaft of length 0.75 m, supported freely at the ends, is carrying a body of mass 90 kg at 0.25 m from one end. Find the natural frequency of transverse vibration. Assume  $E = 200 \text{ GN/m}^2$  and shaft diameter = 50 mm
8. Calculate the whirling speed of a shaft 20 mm diameter and 0.6 m long carrying a mass of 1 kg at its mid-point. The density of the shaft material is  $40 \text{ Mg/m}^3$  , and Young's modulus is  $200 \text{ GN/m}^2$  . Assume the shaft to be freely supported
9. Define, in short, free vibrations, forced vibrations and damped vibrations.
10. Discuss the effect of inertia of the shaft in longitudinal and transverse vibrations.





---

# UNIT 5

# GOVERNORS

---



## **Course Objectives**

To understand the working principles of different type governors and its characteristics

## **Course Outcomes**

Student gets the exposure of different governors and its working principle



## INTRODUCTION

The function of a governor is to regulate the mean speed of an engine, when there are variations in the load *e.g.* when the load on an engine increases, its speed decreases, Therefore it becomes necessary to increase the supply of working fluid. On the other hand, when the load on the engine decreases, its speed increases and thus less working fluid is required. The governor automatically controls the supply of working fluid to the engine with the varying load conditions and keeps the mean speed within certain limits. A little consideration will show, that when the load increases, the configuration of the governor changes and a valve is moved to increase the supply of the working fluid **conversely**, when the load decreases, the engine speed increases and the governor decreases the supply of working fluid.

Classifications of the governor

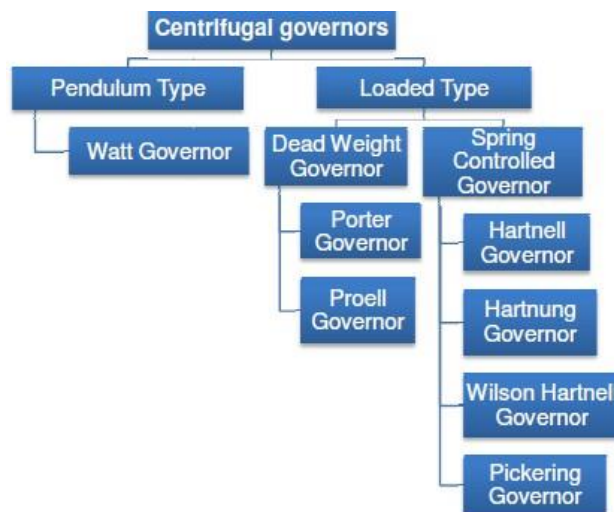

### Centrifugal Governors

The centrifugal governors are based on the balancing of centrifugal force on the rotating balls by an equal and opposite radial force, known as the controlling force\*. It consists of two balls of equal mass, which are attached to the arms as shown in Fig. These balls are known as governor balls or fly balls. The balls revolve with a spindle, which is driven by the engine through bevel gears. The upper ends of the arms are pivoted to the spindle, so that the balls may rise up or fall down as they revolve about the vertical axis. The arms are connected by the links to a sleeve, which is keyed to the spindle. This sleeve revolves with the spindle but can slide up and down. The balls and the sleeve rise when the spindle speed increases, and falls when the speed decreases. In order to limit the travel of the sleeve in upward and downward directions, two stops *S, S* are provided on the spindle. The sleeve is connected by a bell crank lever to a throttle valve. The supply of the working fluid decreases when the sleeve rises and increases when it falls. When the load on the engine increases, the engine



and the governor speed decreases. This results in the decrease of centrifugal force on the balls. Hence the balls move inwards and the sleeve moves downwards. The downward movement of the sleeve operates a throttle valve at the other end of the bell crank lever to

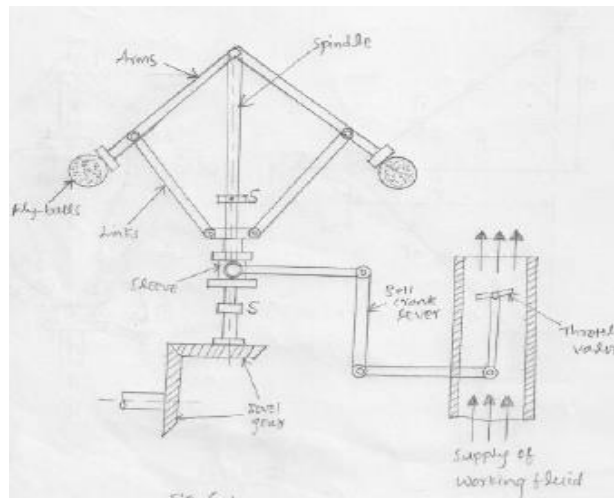

increase the supply of working fluid and thus the engine speed is increased.

In this case, the extra power output is provided to balance the increased load. When the load on the engine decreases, the engine and the governor speed increases, which results in the increase of centrifugal force on the balls. Thus the balls move outwards and the sleeve rises upwards. This upward movement of the sleeve reduces the supply of the working fluid and hence the speed is decreased. In this case, the power output is reduced.

### Watt Governor

The simplest form of a centrifugal governor is a Watt governor, as shown in Fig. It is basically a conical pendulum with links attached to a sleeve of negligible mass. The arms of the governor may be connected to the spindle in the following three ways governor may be connected to the spindle in the following three ways:

The pivot  $P$ , may be on the spindle axis as shown in Fig.(a).

The pivot  $P$ , may be offset from the spindle axis and the arms when produced intersect at  $O$ , as shown in Fig.(b).

The pivot  $P$ , may be offset, but the arms cross the axis at  $O$ , as shown in Fig(a)

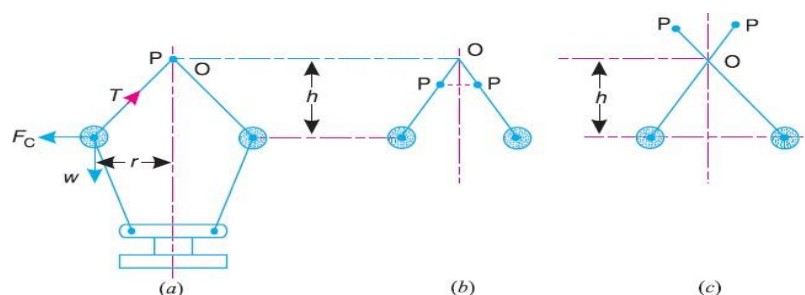

Let  $m$  = Mass of the ball in kg,

$w$  = Weight of the ball in newtons =  $m.g$ ,  $T$  = Tension in the arm in newtons,

$\omega$  = Angular velocity of the arm and ball about the spindle axis in rad/s,

$r$  = Radius of the path of rotation of the ball i.e. horizontal distance from the centre of the ball to the spindle axis in metres,

$F_C$  = Centrifugal force acting on the ball in newtons =  $m.\omega^2.r$ , and

$h$  = Height of the governor in metres.

It is assumed that the weight of the arms, links and the sleeve are negligible as compared to the weight of the balls. Now, the ball is in equilibrium under the action of the centrifugal force ( $F_C$ ) acting on the ball, the tension ( $T$ ) in the arm, and the weight ( $w$ ) of the ball.

Taking moments about point  $O$ , we have

$$F_C \times h = w \times r = m.g.r$$

$$m.\omega^2.r.h = m.g.r \quad \text{or} \quad h = g/\omega^2$$

When  $g$  is expressed in  $m/s^2$  and  $\omega$  in rad/s, then  $h$  is in metres. If  $N$  is the speed in r.p.m., then

$$\omega = 2\pi N/60$$

$$h = \frac{9.81}{(2\pi N/60)^2} = \frac{895}{N^2} \text{ metres}$$

### Porter Governor

The Porter governor is a modification of a Watt's governor, with central load attached to the sleeve as shown in Fig (a). The load moves up and down the central spindle. This additional downward force increases the speed of revolution required to enable the balls to rise to any predetermined level. Consider the forces acting on one-half of the governor as shown in Fig (b)

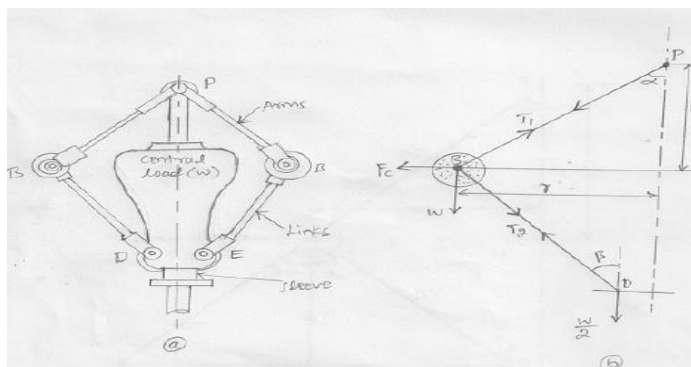

Let  $m$  = Mass of each ball in kg,

$w$  = Weight of each ball in newtons =  $m.g$ ,  $M$  = Mass of the central load in kg,

$W$  = Weight of the central load in newtons =  $M.g$ ,  $r$  = Radius of rotation in metres,



$h$  = Height of governor in metres ,

$N$  = Speed of the balls in r.p.m .,

$\omega$  = Angular speed of the balls in rad/s

=  $2\pi N/60$  rad/s,

$F_C$  = Centrifugal force acting on the ball in newtons =  $m.\omega^2.r$ ,

$T_1$  = Force in the arm in newtons,

$T_2$  = Force in the link in newtons,

$\alpha$  = Angle of inclination of the arm (or upper link) to the vertical, and

$\beta$  = Angle of inclination of the link (or lower link) to the vertical.

Though there are several ways of determining the relation between the height of the governor ( $h$ ) and the angular speed of the balls ( $\omega$ ), yet the following two methods are important from the subject point of view.

### Method of resolution of forces Instantaneous centre method

#### Method of resolution of forces

Considering the equilibrium of the forces acting at  $D$ , we have

$$T_2 \cos \beta = \frac{W}{2} = \frac{M \cdot g}{2}$$
$$T_2 = \frac{M \cdot g}{2 \cos \beta}$$

Again, considering the equilibrium of the forces acting on  $B$ . The point  $B$  is in equilibrium under the action of the following forces, as shown in Fig(b).

The weight of ball ( $w = m.g$ ),

The centrifugal force ( $F_C$ ),

The tension in the arm ( $T_1$ ), and

The tension in the link ( $T_2$ ).

Resolving the forces vertically,

$$T_1 \cos \alpha = T_2 \cos \beta + w = \frac{M \cdot g}{2} + m.g \quad \dots (ii)$$

Resolving the forces horizontally,

$$T_1 \sin \alpha + T_2 \sin \beta = F_C$$

$$T_1 \sin \alpha + \frac{M \cdot g}{2 \cos \beta} \times \sin \beta = F_C \quad \dots \left( \because T_2 = \frac{M \cdot g}{2 \cos \beta} \right)$$

$$T_1 \sin \alpha + \frac{M \cdot g}{2} \times \tan \beta = F_C$$

$$T_1 \sin \alpha = F_C - \frac{M \cdot g}{2} \times \tan \beta \quad \dots (iii)$$

Dividing equation (iii) by equation (ii),

$$\frac{T_1 \sin \alpha}{T_1 \cos \alpha} = \frac{F_C - \frac{M \cdot g}{2} \times \tan \beta}{\frac{M \cdot g}{2} + m.g}$$



or 
$$\left( \frac{M \cdot g}{2} + m \cdot g \right) \tan \alpha = F_C - \frac{M \cdot g}{2} \times \tan \beta$$

$$\frac{M \cdot g}{2} + m \cdot g = \frac{F_C}{\tan \alpha} - \frac{M \cdot g}{2} \times \frac{\tan \beta}{\tan \alpha}$$

Substituting  $\frac{\tan \beta}{\tan \alpha} = q$ , and  $\tan \alpha = \frac{r}{h}$ , we have

Instantaneous centre method

$$\frac{M \cdot g}{2} + m \cdot g = m \cdot \omega^2 \cdot r \times \frac{h}{r} - \frac{M \cdot g}{2} \times q \quad \dots (\because F_C = m \cdot \omega^2 \cdot r)$$

$$m \cdot \omega^2 \cdot h = m \cdot g + \frac{M \cdot g}{2} (1 + q)$$

$$\omega^2 = \left[ m \cdot g + \frac{M \cdot g}{2} (1 + q) \right] \frac{1}{m \cdot h} = \frac{m + \frac{M}{2} (1 + q)}{m} \times \frac{g}{h}$$

$$\left( \frac{2\pi N}{60} \right)^2 = \frac{m + \frac{M}{2} (1 + q)}{m} \times \frac{g}{h}$$

$$N^2 = \frac{m + \frac{M}{2} (1 + q)}{m} \times \frac{g}{h} \left( \frac{60}{2\pi} \right)^2 = \frac{m + \frac{M}{2} (1 + q)}{m} \times \frac{895}{h} \quad \dots (v)$$

In this method, equilibrium of the forces acting on the link  $BD$  are considered. The instantaneous centre/ lies at the point of intersection of  $PB$  produced and a line through  $D$  perpendicular to the spindle axis, as shown in Fig. 18.4. Taking moments about the point/

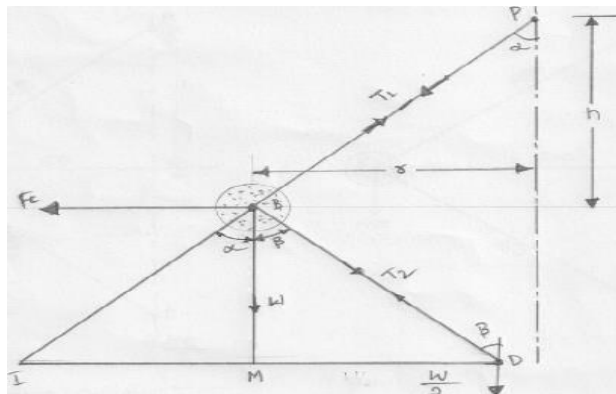

$$F_C \times BM = w \times IM + \frac{W}{2} \times ID$$

$$= m \cdot g \times IM + \frac{M \cdot g}{2} \times ID$$

$$F_C = m \cdot g \times \frac{IM}{BM} + \frac{M \cdot g}{2} \times \frac{ID}{BM}$$

$$= m \cdot g \times \frac{IM}{BM} + \frac{M \cdot g}{2} \left( \frac{IM + MD}{BM} \right)$$

$$= m \cdot g \times \frac{IM}{BM} + \frac{M \cdot g}{2} \left( \frac{IM}{BM} + \frac{MD}{BM} \right)$$

$$= m \cdot g \tan \alpha + \frac{M \cdot g}{2} (\tan \alpha + \tan \beta)$$

$$\therefore m \omega^2 \cdot r \times \frac{h}{r} = m \cdot g + \frac{M \cdot g}{2} (1+q)$$

$$h = \frac{m \cdot g + \frac{M \cdot g}{2} (1+q)}{m} \times \frac{1}{\omega^2} = \frac{m + \frac{M}{2} (1+q)}{m} \times \frac{g}{\omega^2}$$

... (Same as before)

When  $\tan \alpha = \tan \beta$  or  $q = 1$ , then

$$h = \frac{m + M}{m} \times \frac{g}{\omega^2}$$

## PROBLEMS

**Example1.** A Porter governor has equal arms each 250 mm long and pivoted on the axis of rotation. Each ball has a mass of 5 kg and the mass of the central load on the sleeve is 25 kg. The radius of rotation of the ball is 150 mm when the governor begins to lift and 200 mm when the governor is at maximum speed. Find the minimum and maximum speeds and range of speed of the governor.

**Solution.** Given :  $BP = BD = 250 \text{ mm} = 0.25 \text{ m}$  ;  $m = 5 \text{ kg}$  ;  $M = 15 \text{ kg}$  ;

$r_1 = 150 \text{ mm} = 0.15 \text{ m}$  ;  $r_2 = 200 \text{ mm} = 0.2 \text{ m}$

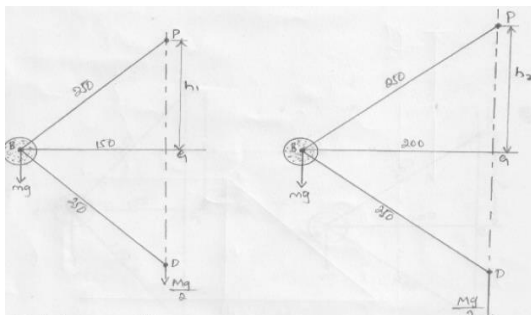

The minimum and maximum positions of the governor are shown in Fig.(a) and (b) respectively.



Minimum speed when  $r_1 = BG = 0.15 \text{ m}$

Let  $N_1 = \text{Minimum speed.}$

From Fig.(a), we find that height of the governor,

$$h_1 = PG = \sqrt{(PB)^2 - (BG)^2} = \sqrt{(0.25)^2 - (0.15)^2} = 0.2 \text{ m}$$

We know that

$$(N_1)^2 = \frac{m + M}{m} \times \frac{895}{h_1} = \frac{5 + 15}{5} \times \frac{895}{0.2} = 17\,900$$

$N_1 = 133.8 \text{ r.p.m.}$

Maximum speed when  $r_2 = BG = 0.2 \text{ m}$  Let  $N_2 = \text{Maximum speed.}$

From Fig(b), we find that height of the governor,

$$h_2 = PG = \sqrt{(PB)^2 - (BG)^2} = \sqrt{(0.25)^2 - (0.2)^2} = 0.15 \text{ m}$$

$$(N_2)^2 = \frac{m + M}{m} \times \frac{895}{h_2} = \frac{5 + 15}{5} \times \frac{895}{0.15} = 23\,867$$

$N_2 = 154.5 \text{ r.p.m.}$

Range of speed

We know that range of speed =  $N_2 - N_1 = 154.4 - 133.8 = 20.7 \text{ r.p.m.}$

## Proell Governor

The Proell governor has the balls fixed at  $B$  and  $C$  to the extension of the links  $DF$  and  $EG$ , as shown in Fig(a). The arms  $FP$  and  $GQ$  are pivoted at  $P$  and  $Q$  respectively.

Consider the equilibrium of the forces on one-half of the governor as shown in Fig (b).The instantaneous centre ( $I$ ) lies on the intersection of the line  $PF$  produced and the line from  $D$  drawn perpendicular to the spindle axis. The perpendicular  $BM$  is drawn on  $ID$ .

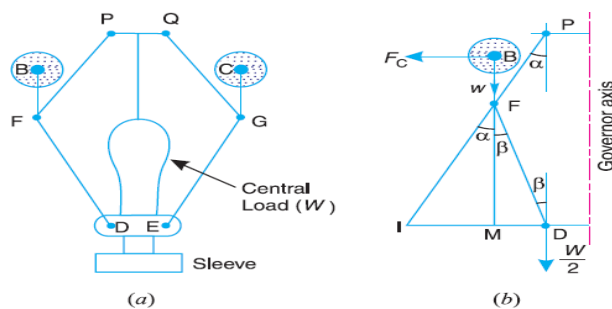

Taking moments about  $I$ ,

$$F_C \times BM = w \times IM + \frac{W}{2} \times ID = m \cdot g \times IM + \frac{M \cdot g}{2} \times ID \quad \dots (i)$$

$$\therefore F_C = m \cdot g \times \frac{IM}{BM} + \frac{M \cdot g}{2} \left( \frac{IM + MD}{BM} \right) \quad \dots (\because ID = IM + MD)$$

Multiplying and dividing by  $FM$ , we have



$$\begin{aligned}
 F_C &= \frac{FM}{BM} \left[ m \cdot g \times \frac{IM}{FM} + \frac{M \cdot g}{2} \left( \frac{IM}{FM} + \frac{MD}{FM} \right) \right] \\
 &= \frac{FM}{BM} \left[ m \cdot g \times \tan \alpha + \frac{M \cdot g}{2} (\tan \alpha + \tan \beta) \right] \\
 &= \frac{FM}{BM} \times \tan \alpha \left[ m \cdot g + \frac{M \cdot g}{2} \left( 1 + \frac{\tan \beta}{\tan \alpha} \right) \right]
 \end{aligned}$$

We know that  $F_C = m \cdot \omega^2 r$ ;  $\tan \alpha = \frac{r}{h}$  and  $q = \frac{\tan \beta}{\tan \alpha}$

$$\therefore m \cdot \omega^2 \cdot r = \frac{FM}{BM} \times \frac{r}{h} \left[ m \cdot g + \frac{M \cdot g}{2} (1 + q) \right]$$

$$\text{and } \omega^2 = \frac{FM}{BM} \left[ \frac{m + \frac{M}{2} (1 + q)}{m} \right] \frac{g}{h} \quad \dots (ii)$$

Substituting  $\omega = 2\pi N/60$ , and  $g = 9.81 \text{ m/s}^2$ , we get

$$N^2 = \frac{FM}{BM} \left[ \frac{m + \frac{M}{2} (1 + q)}{m} \right] \frac{895}{h} \quad \dots (iii)$$

## PROBLEMS

**Example 1.** A Proell governor has equal arms of length 300 mm. The upper and lower ends of the arms are pivoted on the axis of the governor. The extension arms of the lower links are each 80 mm long and parallel to the axis when the radii of rotation of the balls are 150 mm and 200 mm. The mass of each ball is 10 kg and the mass of the central load is 100 kg. Determine the range of speed of the governor.

**Solution.** Given :  $PF = DF = 300 \text{ mm}$  ;  $BF = 80 \text{ mm}$  ;  $m = 10 \text{ kg}$  ;  $M = 100 \text{ kg}$  ;

$r_1 = 150 \text{ mm}$ ;  $r_2 = 200 \text{ mm}$

First of all, let us find the minimum and maximum speed of the governor. The minimum and maximum position of the governor is shown in Fig (a) Let

$N_1 =$  Minimum speed when radius of rotation,  $r_1 = FG = 150 \text{ mm}$ ;

$N_2 =$  Maximum speed when radius of rotation,  $r_2 = FG = 200 \text{ mm}$ .

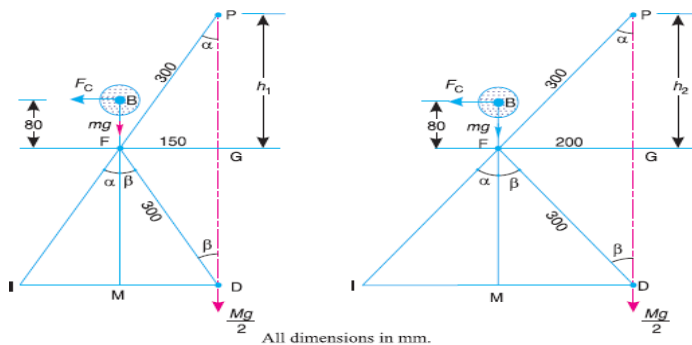

(a) Minimum position.

(a) Maximum position.

From Fig(a), we find that height of the governor,



$$FM = GD = PG = 260 \text{ mm} = 0.26 \text{ m}$$

$$BM = BF + FM = 80 + 260 = 340 \text{ mm} = 0.34 \text{ m}$$

We know that  $(N_1)^2 = \frac{FM}{BM} \left( \frac{m+M}{m} \right) \frac{895}{h_1} \dots (\because \alpha = \beta \text{ or } q = 1)$

$$= \frac{0.26}{0.34} \left( \frac{10+100}{10} \right) \frac{895}{0.26} = 28\,956 \text{ or } N_1 = 170 \text{ r.p.m.}$$

Now from Fig. 18.13 (b), we find that height of the governor,

$$h_2 = PG = \sqrt{(PF)^2 - (FG)^2} = \sqrt{(300)^2 - (200)^2} = 224 \text{ mm} = 0.224 \text{ m}$$

$$FM = GD = PG = 224 \text{ mm} = 0.224 \text{ m}$$

$$\therefore BM = BF + FM = 80 + 224 = 304 \text{ mm} = 0.304 \text{ m}$$

We know that  $(N_2)^2 = \frac{FM}{BM} \left( \frac{m+M}{m} \right) \frac{895}{h_2} \dots (\because \alpha = \beta \text{ or } q = 1)$

$$= \frac{0.224}{0.304} \left( \frac{10+100}{10} \right) \frac{895}{0.224} = 32\,385 \text{ or } N_2 = 180 \text{ r.p.m.}$$

We know that range of speed

$$= N_2 - N_1 = 180 - 170 = 10 \text{ r.p.m. Ans.}$$

## Hartnell Governor

A Hartnell governor is a spring loaded governor as shown in Fig. It consists of two bell crank levers pivoted at the points  $O, O$  to the frame. The frame is attached to the governor spindle and therefore rotates with it. Each lever carries a ball at the end of the vertical arm  $OB$  and a roller at the end of the horizontal arm  $OR$ . A helical spring in compression provides equal downward forces on the two rollers through a collar on the sleeve. The spring force may be adjusted by screwing a nut up or down on the sleeve.

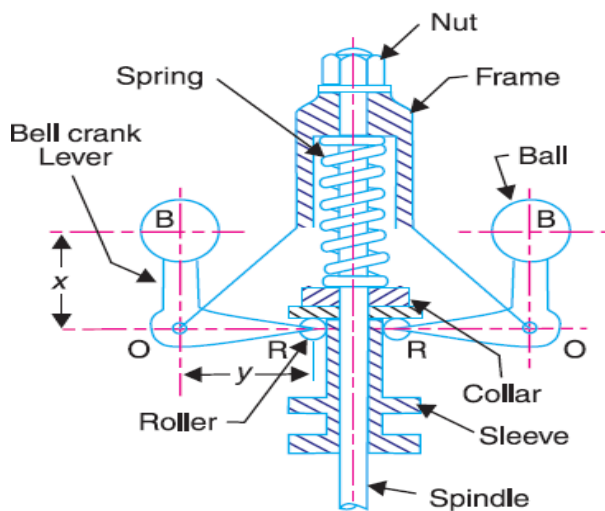

$m$  = Mass of each ball in kg,

$M$  = Mass of sleeve in kg,

$r_1$  = Minimum radius of rotation in metres,

$r_2$  = Maximum radius of rotation in metres,



$\omega_1$  = Angular speed of the governor at minimum radius in rad/s,  $\omega_2$  = Angular speed of the governor at maximum radius in rad/s,  $S_1$  = Spring force exerted on the sleeve at  $\omega_1$  in newtons,

$S_2$  = Spring force exerted on the sleeve at  $\omega_2$  in newtons,  $F_{C1}$  = Centrifugal force at  $\omega_1$  in newtons =  $m (\omega_1)^2 r_1$ ,  $F_{C2}$  = Centrifugal force at  $\omega_2$  in newtons =  $m (\omega_2)^2 r_2$ ,

$s$  = Stiffness of the spring or the force required to compress the spring by one mm,

$x$  = Length of the vertical or ball arm of the lever in metres,

$y$  = Length of the horizontal or sleeve arm of the lever in metres, and

$r$  = Distance of fulcrum  $O$  from the governor axis or the radius of rotation when the governor is in mid-position, in metres.

Consider the forces acting at one bell crank lever. The minimum and maximum position is shown in Fig. Let  $h$  be the compression of the spring when the radius of rotation changes from  $r_1$  to  $r_2$ .

For the minimum position *i.e.* when the radius of rotation changes from  $r$  to  $r_1$ , as shown in

$$\frac{h_1}{y} = \frac{a_1}{x} = \frac{r - r_1}{x}$$

Fig (a), the compression of the spring or the lift of sleeve  $h_1$  is given by

Similarly, for the maximum position *i.e.* when the radius of rotation changes from  $r$  to  $r_2$ , as shown in Fig (b), the compression of the spring or lift of sleeve  $h_2$  is given by

$$\frac{h_2}{y} = \frac{a_2}{x} = \frac{r_2 - r}{x}$$

Adding equations (i) and (ii),

$$\frac{h_1 + h_2}{y} = \frac{r_2 - r_1}{x} \quad \text{or} \quad \frac{h}{y} = \frac{r_2 - r_1}{x} \quad \dots (\because h = h_1 + h_2)$$

$$\therefore h = (r_2 - r_1) \frac{y}{x} \quad \dots (iii)$$

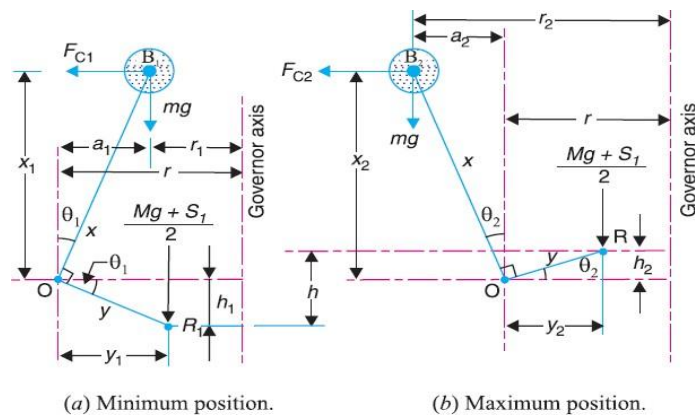

Now for minimum position, taking moments about point  $O$ , we get



$$S_2 - S_1 = h.s, \quad \text{and} \quad h = (r_2 - r_1) \frac{y}{x}$$

$$s = \frac{S_2 - S_1}{h} = 2 \left( \frac{F_{C2} - F_{C1}}{r_2 - r_1} \right) \left( \frac{x}{y} \right)^2 \quad \dots (ix) \quad \dots (iv)$$

Again for maximum position, taking moments about point  $O$ , we get

$$\frac{M \cdot g + S_2}{2} \times y_2 = F_{C2} \times x_2 + m \cdot g \times a_2$$

$$M \cdot g + S_2 = \frac{2}{y_2} (F_{C2} \times x_2 + m \cdot g \times a_2) \quad \dots (v)$$

Subtracting equation (iv) from equation (v),

$$S_2 - S_1 = \frac{2}{y_2} (F_{C2} \times x_2 + m \cdot g \times a_2) - \frac{2}{y_1} (F_{C1} \times x_1 - m \cdot g \times a_1)$$

We know that

$$S_2 - S_1 = h.s, \quad \text{and} \quad h = (r_2 - r_1) \frac{y}{x}$$

$$\therefore s = \frac{S_2 - S_1}{h} = \left( \frac{S_2 - S_1}{r_2 - r_1} \right) \frac{x}{y}$$

Neglecting the obliquity effect of the arms (*i.e.*  $x_1 = x_2 = x$ , and  $y_1 = y_2 = y$ ) and the moment due to weight of the balls (*i.e.*  $m \cdot g$ ), we have for minimum position,

$$\frac{M \cdot g + S_1}{2} \times y = F_{C1} \times x \quad \text{or} \quad M \cdot g + S_1 = 2F_{C1} \times \frac{x}{y} \quad \dots (vi)$$

Similarly for maximum position,

$$\frac{M \cdot g + S_2}{2} \times y = F_{C2} \times x \quad \text{or} \quad M \cdot g + S_2 = 2F_{C2} \times \frac{x}{y} \quad \dots (vii)$$

Subtracting equation (vi) from equation (vii),

$$S_2 - S_1 = 2 (F_{C2} - F_{C1}) \frac{x}{y} \quad \dots (viii)$$

## PROBLEMS

Example1. A Hartnell governor having a central sleeve spring and two right-angled bell crank levers moves between 290 r.p.m. and 310 r.p.m. for a sleeve lift of 15 mm. The sleeve arm sand the ball arms are 80 mm and 120 mm respectively. The levers are pivoted at 120 mm from the governor axis and mass of each ball is 2.5 kg. The ball arms are parallel to the



governor axis at the lowest equilibrium speed. Determine loads on the spring at the lowest and the highest equilibrium speeds, and Stiffness of the spring.

**Solution.** Given :  $N_1 = 290$  r.p.m. or  $\omega_1 = 2\pi \times 290/60 = 30.4$  rad/s ;  $N_2 = 310$  r.p.m. or  $\omega_2 = 2\pi \times 310/60 = 32.5$  rad/s ;  $h = 15$  mm = 0.015 m ;  $y = 80$  mm = 0.08 m ;  $x = 120$  mm = 0.12 m ;  $r = 120$  mm = 0.12 m ;  $m = 2.5$  kg  
Loads on the spring at the lowest and highest equilibrium speeds

Let  $S_1$  = Spring load at lowest equilibrium speed, and

$S_2$  = Spring load at highest equilibrium speed.

Since the ball arms are parallel to governor axis at the lowest equilibrium speed (i.e. at  $N_1 = 290$  r.p.m.), as shown in Fig(a), therefore

$$r = r_1 = 120 \text{ mm} = 0.12 \text{ m}$$

We know that centrifugal force at the minimum speed,

$$F_{C1} = m (\omega_1)^2 r_1 = 2.5 (30.4)^2 0.12 = 277 \text{ N}$$

Now let us find the radius of rotation at the highest equilibrium speed, i.e. at

$N_2 = 310$  r.p.m. The position of ball arm and sleeve arm at the highest equilibrium speed is shown in Fig(b).

Let  $r_2$  = Radius of rotation at  $N_2 = 310$  r.p.m.

We know that 
$$h = (r_2 - r_1) \frac{y}{x}$$

$$r_2 = r_1 + h \left( \frac{x}{y} \right) = 0.12 + 0.015 \left( \frac{0.12}{0.08} \right) = 0.1425 \text{ m}$$

Centrifugal force at the maximum speed,

$$F_{C2} = m (\omega_2)^2 r_2 = 2.5 \times (32.5)^2 \times 0.1425 = 376 \text{ N}$$

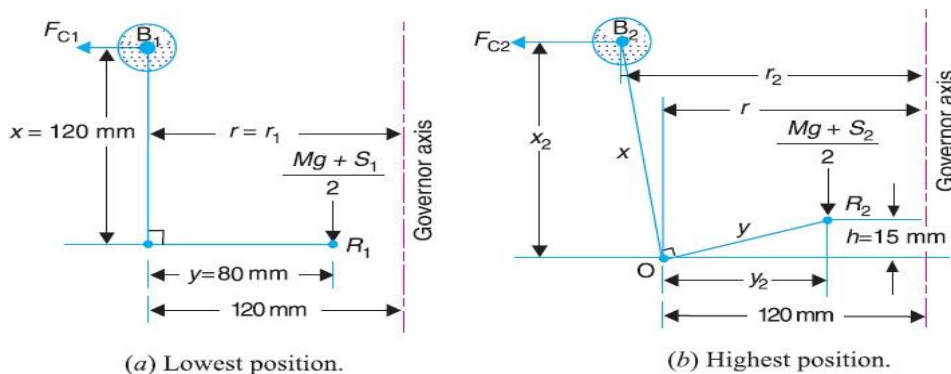

Neglecting the obliquity effect of arms and the moment due to the weight of the balls, we have for lowest position,



$$M \cdot g + S_1 = 2F_{C1} \times \frac{x}{y} = 2 \times 277 \times \frac{0.12}{0.08} = 831 \text{ N}$$

$$S_2 = 831 \text{ N Ans.} \quad (\because M = 0)$$

and for highest position,

$$M \cdot g + S_2 = 2F_{C2} \times \frac{x}{y} = 2 \times 376 \times \frac{0.12}{0.08} = 1128 \text{ N}$$

$$\therefore S_1 = 1128 \text{ N Ans.} \quad (\because M = 0)$$

Stiffness of the spring

We know that stiffness of the spring,

$$s = \frac{S_2 - S_1}{h} = \frac{1128 - 831}{15} = 19.8 \text{ N/mm}$$

### Hartung Governor

A spring controlled governor of the Hartung type is shown in Fig. (a). In this type of governor, the vertical arms of the bell crank levers are fitted with spring balls which compress against the frame of the governor when the rollers at the horizontal arm press against the sleeve.

Let  $S$  = Spring force,

$F_C$  = Centrifugal force,

$M$  = Mass on the sleeve, and

$x$  and  $y$  = Lengths of the vertical and horizontal arm of the bell crank lever respectively.

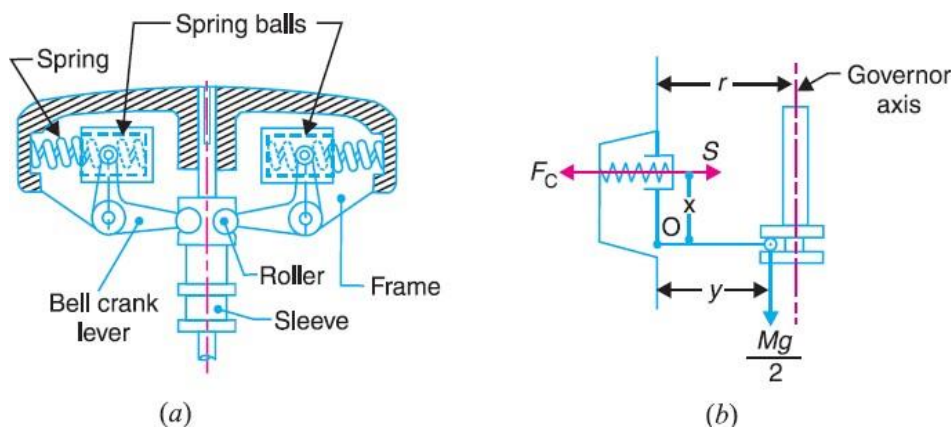

Fig (a) and (b) show the governor in mid-position. Neglecting the effect of obliquity of the arms, taking moments about the fulcrum O,

$$F_C \times x = S \times x + \frac{M \cdot g}{2} \times y$$



## Sensitiveness of Governors

Consider two governors  $A$  and  $B$  running at the same speed. When this speed increases or decreases by a certain amount, the lift of the sleeve of governor  $A$  is greater than the lift of the sleeve of governor  $B$ . It is then said that the governor  $A$  is more sensitive than the governor  $B$ .

In general, the greater the lift of the sleeve corresponding to a given fractional change in speed, the greater is the sensitiveness of the governor. It may also be stated in another way that for a given lift of the sleeve, the sensitiveness of the governor increases as the speed range decreases. This definition of sensitiveness may be quite satisfactory when the governor is considered as an independent mechanism. But when the governor is fitted to an engine, the practical requirement is simply that the change of equilibrium speed from the full load to the no load position of the sleeve should be as small a fraction as possible of the mean equilibrium speed.

The actual displacement of the sleeve is immaterial, provided that it is sufficient to change the energy supplied to the engine by the required amount. For this reason, the sensitiveness is defined as the **ratio of the difference between the maximum and minimum equilibrium speeds to the mean equilibrium speed**

Let  $N_1$  = Minimum equilibrium speed,

$N_2$  = Maximum equilibrium speed, and

$N$  = Mean equilibrium speed =  $(N_1 + N_2)/2$

∴ Sensitiveness of the governor

$$\begin{aligned} &= \frac{N_2 - N_1}{N} = \frac{2(N_2 - N_1)}{N_1 + N_2} \\ &= \frac{2(\omega_2 - \omega_1)}{\omega_1 + \omega_2} \quad \dots \text{(In terms of angular speeds)} \end{aligned}$$

## Stability of Governors

A governor is said to be **stable** when for every speed within the working range there is a definite configuration *i.e.* there is only one radius of rotation of the governor balls at which the governor is in equilibrium. For a stable governor, if the equilibrium speed increases, the radius of governor balls must also increase.

## Isochronous Governors

A governor is said to be **isochronous** when the equilibrium speed is constant (*i.e.* range of speed is zero) for all radii of rotation of the balls within the working range, neglecting friction. The isochronism is the stage of infinite sensitivity.

Let us consider the case of a Porter governor running at speeds  $N_1$  and  $N_2$  r.p.m.



$$(N_1)^2 = \frac{m + \frac{M}{2}(1+q)}{m} \times \frac{895}{h_1} \quad \dots (i)$$

$$(N_2)^2 = \frac{m + \frac{M}{2}(1+q)}{m} \times \frac{895}{h_2} \quad \dots (ii)$$

For isochronisms, range of speed should be zero i.e.  $N_2 - N_1 = 0$  or  $N_2 = N_1$ . Therefore from equations (i) and (ii),  $h_1 = h_2$ , which is impossible in case of a Porter governor. Hence a **Porter governor cannot be isochronous**.

Now consider the case of a Hartnell governor running at speeds  $N_1$  and  $N_2$  r.p.m.

$$M \cdot g + S_1 = 2 F_{C1} \times \frac{x}{y} = 2 \times m \left( \frac{2\pi N_1}{60} \right)^2 r_1 \times \frac{x}{y} \quad \dots (iii)$$

$$M \cdot g + S_2 = 2 F_{C2} \times \frac{x}{y} = 2 \times m \left( \frac{2\pi N_2}{60} \right)^2 r_2 \times \frac{x}{y} \quad \dots (iv)$$

$$\frac{M \cdot g + S_1}{M \cdot g + S_2} = \frac{r_1}{r_2}$$

For isochronisms,  $N_2 = N_1$ . Therefore from equations (iii) and (iv),  
Hunting

A governor is said to be **hunt** if the speed of the engine fluctuates continuously above and below the mean speed. This is caused by a too sensitive governor which changes the fuel supply by a large amount when a small change in the speed of rotation takes place. For example, when the load on the engine increases, the engine speed decreases and, if the governor is very sensitive, the governor sleeve immediately falls to its lowest position. This will result in the opening of the control valve wide which will supply the fuel to the engine in excess of its requirement so that the engine speed rapidly increases again and the governor sleeve rises to its highest position. Due to this movement of the sleeve, the control valve will cut off the fuel supply to the engine and thus the engine speed begins to fall once again. This cycle is repeated indefinitely. Such a governor may admit either the maximum or the minimum amount of fuel. The effect of this will be to cause wide fluctuations in the engine speed or in other words, the engine will hunt



## INDUSTRIAL APPLICATIONS

Diesel Generators



Gas Engine Governors

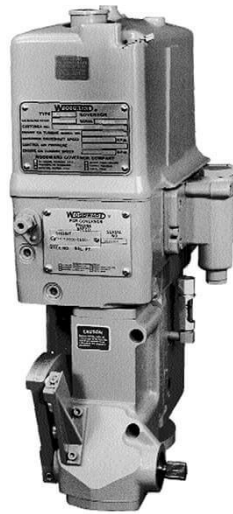

In steam Turbines



## TUTORIAL QUESTIONS

1. Explain types of governors?
2. A Porter governor has all four arms 250 mm long. The upper arms are attached on the axis of rotation and the lower arms are attached to the sleeve at a distance of 30 mm from the axis. The mass of each ball is 5 kg and the sleeve has a mass of 50 kg. The extreme radii of rotation are 150 mm and 200 mm. Determine the range of speed of the governor.
3. A Proell governor has equal arms of length 300 mm. The upper and lower ends of the arms are pivoted on the axis of the governor. The extension arms of the lower links are each 80 mm long and parallel to the axis when the radii of rotation of the balls are 150 mm and 200 mm. The mass of each ball is 10 kg and the mass of the central load is 100 kg. Determine the range of speed of the governor.
4. In a spring loaded Hartnell type governor, the extreme radii of rotation of the balls are 80 mm and 120 mm. The ball arm and the sleeve arm of the bell crank lever are equal in length. The mass of each ball is 2 kg. If the speeds at the two extreme positions are 400 and 420 r.p.m., find : 1. the initial compression of the central spring, and 2. the spring constant.
5. In a spring controlled governor of the type, as shown in Fig. 18.24, the mass of each ball is 1.5 kg and the mass of the sleeve is 8 kg. The two arms of the bell crank lever are at right angles and their lengths are  $OB = 100$  mm and  $OA = 40$  mm. The distance of the fulcrum O of each bell crank lever from the axis of rotation is 50 mm and minimum radius of rotation of the governor balls is also 50 mm. The corresponding equilibrium speed is 240 r.p.m. and the sleeve is required to lift 10 mm for an increase in speed of 5 per cent. Find the stiffness and initial compression of the spring
6. A spring loaded governor of the Wilson-Hartnell type is shown in Fig 18.50. Two balls each of mass 4 kg are connected across by two springs A. The stiffness of each spring is 750 N/m and a free length of 100 mm. The length of ball arm of each bell crank lever is 80 mm and that of sleeve arm is 60 mm. The lever is pivoted at its mid-point. The speed of the governor is 240 r.p.m. in its mean position and the radius of rotation of the ball is 80 mm. If the lift of the sleeve is 7.5 mm for an increase of speed of 5%, find the required stiffness of the auxiliary spring B.



## ASSIGNMENT QUESTIONS

1. The arms of a Porter governor are each 250 mm long and pivoted on the governor axis. The mass of each ball is 5 kg and the mass of the central sleeve is 30 kg. The radius of rotation of the balls is 150 mm when the sleeve begins to rise and reaches a value of 200 mm for maximum speed. Determine the speed range of the governor. If the friction at the sleeve is equivalent of 20 N of load at the sleeve, determine how the speed range is modified.
2. The arms of a Porter governor are 300 mm long. The upper arms are pivoted on the axis of rotation. The lower arms are attached to a sleeve at a distance of 40 mm from the axis of rotation. The mass of the load on the sleeve is 70 kg and the mass of each ball is 10 kg. Determine the equilibrium speed when the radius of rotation of the balls is 200 mm. If the friction is equivalent to a load of 20 N at the sleeve, what will be the range of speed for this position ?
3. A governor of the Proell type has each arm 250 mm long. The pivots of the upper and lower arms are 25 mm from the axis. The central load acting on the sleeve has a mass of 25 kg and the each rotating ball has a mass of 3.2 kg. When the governor sleeve is in mid-position, the extension link of the lower arm is vertical and the radius of the path of rotation of the masses is 175 mm. The vertical height of the governor is 200 mm. If the governor speed is 160 r.p.m. when in mid-position, find :  
1. length of the extension link; and 2. tension in the upper arm.
4. A Hartnell governor having a central sleeve spring and two right-angled bell crank levers moves between 290 r.p.m. and 310 r.p.m. for a sleeve lift of 15 mm. The sleeve arms and the ball arms are 80 mm and 120 mm respectively. The levers are pivoted at 120 mm from the governor axis and mass of each ball is 2.5 kg. The ball arms are parallel to the governor axis at the lowest equilibrium speed. Determine :  
1. loads on the spring at the lowest and the highest equilibrium speeds, and 2. stiffness of the spring.
5. In a spring-controlled governor of the Hartung type, the length of the ball and sleeve arms are 80 mm and 120 mm respectively. The total travel of the sleeve is 25 mm. In the mid position, each spring is compressed by 50 mm and the radius of rotation of the mass centres is 140 mm. Each ball has a mass of 4 kg and the spring has a stiffness of 10 kN/m of compression. The equivalent mass of the governor gear at the sleeve is 16 kg. Neglecting the moment due to the revolving masses when the arms are inclined, determine the ratio of the range of speed to the mean speed of the governor. Find, also, the speed in the mid-position.



6. Explain the term height of the governor. Derive an expression for the height in the case of a Watt governor. What are the limitations of a Watt governor ?
7. What is stability of a governor ?
8. Define and explain the following terms relating to governors : 1. Stability, 2. Sensitiveness, 3. Isochronism, and 4. Hunting



**III B.Tech I Semester Supplementary Examinations, October/November - 2019**  
**DYNAMICS OF MACHINERY**

(Common to Mechanical Engineering, Automobile Engineering)

Time: 3 hours

Max. Marks: 70

Note: 1. Question Paper consists of two parts (**Part-A** and **Part-B**)

2. Answering the question in **Part-A** is compulsory

3. Answer any **THREE** Questions from **Part-B**

**PART -A**

(22 Marks)

- |   |   |      |
|---|---|------|
| 1 | a) Identify the physical terms used to explain gyroscopic action on the sailing ship. | [4M] |
|   | b) What is a friction circle?   | [3M] |
|   | c) Write short note on Raleigh's method.  | [4M] |
|   | d) Explain the significance of area under turning moment diagram.                     | [3M] |
|   | e) Define the sensitiveness of a governor.  | [4M] |
|   | f) What is static balancing?  | [4M] |

**PART -B**

(48 Marks)

- |   |   |       |
|---|---|-------|
| 2 | a) Explain the gyroscopic effect on four wheeled vehicles.  | [8M]  |
|   | b) The rotor of the turbine of a ship makes 1500 rpm clockwise when viewed from the stern. The rotor has a mass of 800 kg and its radius of gyration is 300 mm. Find the maximum gyro-couple transmitted to the hull when the ship pitches with maximum angular velocity of 1 rad/s.  | [8M]  |
| 3 | a) Derive from first principles, the expression for the frictional moment (or torque due to friction) of a conical pivot assuming uniform pressure.   | [8M]  |
|   | b) A multi-disc clutch has 5 plates having four pairs of active friction surfaces. If the intensity of pressure is not to exceed $127 \text{ kN/m}^2$ , find the power in kW transmitted at 500 rpm, if the outer and inner radii of friction surfaces are 1.25 mm and 75 mm respectively. Assume uniform wear and take coefficient of friction as 0.3.   | [8M]  |
| 4 | In a turning moment diagram the areas above and below the mean torque line taken in order are 5.81, 3.23, 3.87, 5.16, 1.94, 3.87, 2.58, and 1.94 sq-cm respectively. The scales of the turning moment diagram are: Turning moment 1 cm is equal to 700 kg/m Crank angle 1 cm is equal to 60 deg. The mean speed of engine is 1200 rpm and the variation of speed must not exceed $\pm 3$ percent of the mean speed. Assuming the radius of gyration of the flywheel to be 106.67 cm, find the weight of flywheel to keep the speed within the given limits. | [16M] |
| 5 | a) With a neat sketch, explain the working of a Hartnell governor.  | [8M]  |
|   | b) Calculate the minimum speed, maximum speed and range of speed of a Porter governor, which has equal arms each 250 mm long and pivoted on the axis of rotation. The mass of each ball is 6 kg and the central mass on the sleeve is 18 kg. The radius of rotation of ball is 150 mm when the governor begins to lift and 200 mm when the governor is at the maximum speed.  | [8M]  |

- 6 a) Explain the terms: variation of tractive force, swaying couple, and hammer blow. [8M]  
b) Three masses P, Q and R with masses 12 kg, 11 kg and 18 kg respectively revolve in the same plane at radii 120 mm, 144 mm and 70 mm respectively. The angular position of Q and R are 60° and 135° from P. Determine the position and magnitude of mass S at radius 152 mm to balance the system. [8M]
- 7 a) Derive an expression for the damping coefficient in terms of the circular frequency, mass of the vibrating body, and damping factor. [8M]  
b) A shaft of 10 cm diameter and 100 cm long is fixed at one end and other end carries a flywheel of mass 80 kg. Taking young's modulus for the shaft material as  $2 \times 10^6 \text{ kg/cm}^2$ , find the natural frequency of longitudinal and transverse vibrations. [8M]

\*\*\*\*\*

**III B. Tech I Semester Supplementary Examinations, October/November - 2018****DYNAMICS OF MACHINERY**

(Common to Mechanical Engineering and Automobile Engineering)

Time: 3 hours

Max. Marks: 70

Note: 1. Question Paper consists of two parts (**Part-A** and **Part-B**)2. Answering the question in **Part-A** is compulsory3. Answer any **THREE** Questions from **Part-B****PART -A**

- 1 a) Write the effect of precession motion on the stability of moving vehicles? [4M]
- b) Classify the types of dynamometers? [4M]
- c) Explain the need for Dynamic force analysis [3M]
- d) Write about hunting? [4M]
- e) What for balancing of rotating masses are required [4M]
- f) Explain the necessity of forced damped vibration [3M]

**PART -B**

- 2 a) Explain in what way the gyroscopic couple effects the motion of an aircraft while taking a turn. [6M]
- b) The moment of inertia of a pair of locomotive driving wheels with the axle is  $200 \text{ kg.m}^2$ . The distance between the wheel centers is 1.6 m and the diameter of the wheel treads is 1.8 m. Due to defective ballasting, one wheel falls by 5 mm and raises again in a total time of 0.12 seconds while the locomotive travels on a level track at 100 km/h. assuming that the displacement of the wheel takes place with simple harmonic motion, determine the gyroscopic couple produced and the reaction between the wheel and rail due to this couple. [10M]
- 3 a) A simple band brake is operated by a lever of length 450 mm. The brake drum has a diameter of 600 mm, and the brake band embraces  $\frac{5}{8}$ <sup>th</sup> of the circumference. One end of the band is attached to the fulcrum of the lever while the other end is attached to a pin on the lever 120 mm from the fulcrum. The effort applied to the end of the lever is 2 kN, and the coefficient of friction is 0.30. Find the maximum braking torque on the drum. [10M]
- b) Explain about epicyclic train dynamometer with neat diagram? [6M]
- 4 The turning moment requirement of a machine is represented by the equation  $T = (1000 + 500 \sin 2\theta - 300 \cos 2\theta) \text{ N-m}$ . Where  $\theta$  is the angle turned by the crankshaft of the machine? If the supply torque is constant, determine: [16M]
  - i) The moment of inertia by the flywheel. The total fluctuation of speed is not to exceed one percent of the mean speed of 300 rpm.
  - ii) Angular acceleration of the flywheel when the crankshaft has turned through  $45^\circ$  from the beginning of the cycle.
  - iii) The power required to drive the machine.

- 5 The arms of a Hartnell governor are of equal length. When the sleeve is in the mid-position, the masses rotate in a circle of diameter 200mm (the arms are vertical in the mid-position). Neglecting friction, the equilibrium speed for this position is 300 rpm. Maximum variation of speed, taking friction into account, is to be  $\pm 5\%$  of the mid-position speed for a maximum sleeve / movement of 25 mm. The sleeve mass is 5 kg and the friction at the sleeve is 30 N. Assuming that the power of the governor is sufficient to overcome the friction by 1 % change of speed on each side of the mid-position, find (neglecting obliquity effect of arms). [16M]
- i) The mass of each rotating ball
  - ii) The spring stiffness
  - iii) The initial compression of the spring
- 6 A single cylinder horizontal engine runs at 120 r.p.m. The length of stroke is 400 mm. The mass of the revolving parts assumed concentrated at the crank pin is 100 kg and mass of reciprocating parts is 150 kg. Determine the magnitude of the balancing mass required to be placed opposite to the crank at a radius of 150mm which is equivalent to all the revolving and  $\frac{2}{3}$  rd of the reciprocating masses. If the crank turns 300 from the inner dead centre, find the magnitude of the unbalanced force due to the balancing mass. [16M]
- 7 a) Derive an equation for the natural frequency of free transverse vibration of a shaft headed with a number of concentrated loads, by energy method. [7M]
- b) A shaft of 10 cm diameter and 100 cm long is fixed at one end and other end carries a flywheel of mass 80 kg. Taking young's modulus for the shaft material as  $2 \times 10^6$  kg/cm<sup>2</sup>, find the natural frequency of longitudinal and transverse vibrations. [9M]

\*\*\*\*\*



**III B. Tech I Semester Regular/Supplementary Examinations, October/November- 2017****DYNAMICS OF MACHINERY**

(Common to Mechanical Engineering and Auto Mobile Engineering)

Time: 3 hours

Max. Marks: 70

- Note: 1. Question Paper consists of two parts (**Part-A** and **Part-B**)  
 2. Answering the question in **Part-A** is compulsory  
 3. Answer any **THREE** Questions from **Part-B**

**PART -A**

- 1 a) Write about pitching and rolling term used in connection with the movement of a natural ship. [3M]  
 b) Define friction force? [4M]  
 c) How does fly wheel differ from that of a governor? [4M]  
 d) Write about hunting. [4M]  
 e) Write about hammer blow? [3M]  
 f) Write about transmissibility. [4M]

**PART -B**

- 2 A trolley car of total weight 3000N runs on rails of 1.5m gauge and travels a curve 30m radius at 8.7 m/s. The rails being at the same level. The car has four wheels of 72cm diameter and each of the two axles is driven by a motor running in a opposite direction to the wheels at a speed of 5 times the speed of rotation of vehicle. Each axle with gear and wheels has a Moment of inertia  $147\text{kg m}^2$ . Each motor with the shaft and gear pinion has a Moment of inertia  $10.5\text{kg m}^2$ . Has centre of gravity 90 cm above the rail level. Allowing the centrifugal and gyroscopic action, determine the vertical force exerted by each wheel on the rails. [16M]
- 3 a) A cone clutch is to be designed to transmit a torque of 1000rpm. The outside and inside radii are 75mm and 45mm respectively. The semi cone angle is 15 degrees. The coefficient of friction of friction lining is 0.35. Using the uniform wear theory, find the required clamping force. If the friction lining wears out by 0.4mm, what reduction in the torque capacity of the clutch. [12M]  
 b) Explain the working operation of rope brake dynamometer in brief? [4M]
- 4 The equation of the turning moment diagram for a three-crank engine is given by  $T \text{ (N-m)} = 25000 - 7500 \sin 3\theta$ , where  $\theta$  radians is the crank angle from the inner dead centre. The moment of inertia of the flywheel is  $400 \text{ kg-m}^2$ , and the mean engine speed is 300 rpm. Calculate the power of the engine and the total percentage fluctuation of speed of the flywheel, if the resisting torque is constant. [16M]



- 5 A Porter governor carries a central load of 30 kgf and each ball weighs 4.5 kgf. The upper links are 20cm long and the lower links are 30 cms long. The points of suspension of upper and lower links are 5cms from axis of spindle. Calculate: i) The speed of the governor in rpm if the radius of revolution of the governor ball is 12.5 cm and ii) The effort of the governor for increase of speed of 1%. [16M]
- 6 A shaft carries four masses A, B, C and D of 12, 20, 30 and 16 kg respectively spaced 18 cms apart. Measuring angle anti clockwise from A, B is  $240^{\circ}$ , C is  $135^{\circ}$  and D is  $270^{\circ}$ . The radii are 15 cm, 12 cm, 6 cm and 18 cm and the speed of the shaft is 120 rpm. Find the magnitude and direction relative to A of the resultant moment at a plane midway between A and B. [16M]
- 7 a) Describe about vibrations of beams with concentrated and distributed loads? [7M]  
b) A machine part having a mass of 2.5 kg vibrates in a viscous medium. A harmonic exciting force of 30 N acts on the part and causes a resonant amplitude of 14 mm with a period of 0.22 second. Find the damping coefficient. If the frequency of the exciting force is changed to 4 Hz, determine the increase in the amplitude of the forced vibrations upon the removal of the damper. [9M]

\*\*\*\*\*



**III B. Tech I Semester Regular/Supplementary Examinations, October/November- 2017**  
**DYNAMICS OF MACHINERY**

(Common to Mechanical Engineering and Auto Mobile Engineering)

Time: 3 hours

Max. Marks: 70

- Note: 1. Question Paper consists of two parts (**Part-A** and **Part-B**)  
 2. Answering the question in **Part-A** is compulsory  
 3. Answer any **THREE** Questions from **Part-B**
- ~~~~~

**PART -A**

- |   |  |      |
|---|--|------|
| 1 | a) Write about steering term used in connection with the movement of a natural ship. | [3M] |
|   | b) Define coefficient of friction?   | [4M] |
|   | c) What is the function of a flywheel?   | [3M] |
|   | d) Write about isochronism.  | [4M] |
|   | e) Write about swaying couple.   | [4M] |
|   | f) Write about vibration isolation.  | [4M] |

**PART -B**

- |   |  |       |
|---|--|-------|
| 2 | a) What is the effect of precision by a body fixed rigidly at certain angle to rotating shaft.   | [4M]  |
|   | b) The propeller of an aero turbine has a weight of 550 N and radius of gyration 0.7m. The propeller shaft rotates at 1000 rpm clockwise viewing from the tail and makes a complete half circle of 250 m radius towards left at a speed of 300 km/hr. Find the gyroscopic couple on the aircraft and state its effect on it. What will be the effect if the aircraft turns to right instead of left?   | [12M] |
| 3 | a) Derive the expression for the torque transmitting capacity of a cone clutch by considering uniform wear.  | [6M]  |
|   | b) A friction clutch is required to transmit 34.5kW at 2000rpm. It is to be single plate disk type with both sides of the plate effective, the pressure is being applied axially by means of springs and limited to 70kPa on the plate. If the outer diameter of the friction limit is 1.5 times the internal diameter, find the required dimensions d1 and d2 of the clutch ring and the total force exerted by the springs. Assume uniform wear condition (coefficient of friction=0.3). | [10M] |
| 4 | a) Explain the effect of inertia force on the reciprocating engine mechanism by drawing the free body diagram of each link.  | [8M]  |
|   | b) Find the maximum and minimum speeds of a flywheel of mass 3250 kg and radius of gyration 1.8 m, when the fluctuation of energy is 112kN-m. The mean speed of the engine is 240rpm.  | [8M]  |



- 5 In a Spring loaded governor of the Hartnell type, the mass of each ball is 1 kg, length of vertical arm of the ball crank lever is 100 mm and that of the horizontal arm is 50 mm. The distance of fulcrum of each bell crank lever is 80 mm from the axis of rotation of the governor. The extreme radii of rotation of the balls are 75 mm and 112.5 mm. The maximum equilibrium speed is 5 percent greater than the minimum equilibrium speed which is 360 rpm. Find, neglecting obliquity of arms, initial compression of the spring and equilibrium speed corresponding to the radius of rotation of 100 mm? [16M]
- 6 The following data apply to an outside cylinder unbalanced locomotive: Mass of rotating parts per cylinder per cylinder = 360 kg. Mass of reciprocating parts per cylinder = 300 kg. Angle between cranks = 90° Crank radius = 300 mm Cylinder centers = 1.75 m Radius of balance masses = 750 mm Wheel centers = 1.45 m If the whole of rotating and 2/3 of the reciprocating parts are to be balanced in planes of driving wheels. Find:  
(i) Magnitude and angular position of balance masses.  
(ii) Speed in kilometers per hour at which the wheel will lift off the rails when the load on each driving wheel is 50 kN and the diameter of tread of driving wheel is 1.8 m.  
(iii) Swaying couple at the speed arrived in the (ii) above. [16M]
- 7 a) Derive an expression for the natural frequency of free transverse vibration of simply supported beam carrying several of point loads by energy method. [8M]  
b) A Shaft 40 mm diameter and 2.5m long has a mass of 15kg per meter length. It is simply supported at the ends and carries three masses 90 kg, 140 kg and 60 kg at 0.8 m, 1.5m and 2m respectively from the left support. Taking  $E = 200$  Gpa, find the frequency of the transverse vibration. [8M]

\*\*\*\*\*



**III B. Tech I Semester Regular/Supplementary Examinations, October/November- 2017****DYNAMICS OF MACHINERY**

(Common to Mechanical Engineering and Auto Mobile Engineering)

Time: 3 hours

Max. Marks: 70

- Note: 1. Question Paper consists of two parts (**Part-A** and **Part-B**)  
 2. Answering the question in **Part-A** is compulsory  
 3. Answer any **THREE** Questions from **Part-B**
- ~~~~~

**PART -A**

- 1 a) Write about starboard and port terms used in connection with the movement of a natural ship. [3M]  
 b) Define limiting friction? [4M]  
 c) Define fluctuation of energy? [4M]  
 d) Write about sensitiveness. [4M]  
 e) Write about variation of tractive effort. [4M]  
 f) Define forced damped vibrations? [3M]

**PART -B**

- 2 A racing car weighs 20 kN. It has a wheel base of 2m, track width 1m and height of C.G.300 mm above the ground level and lies midway between the front and rear axle. The engine flywheel rotates at 3000 rpm clockwise when viewed from the front. The moment of inertia of the flywheel is  $4\text{kg}\cdot\text{m}^2$  and moment of inertia of each wheel is  $3\text{kgm}^2$ . Find the reactions between the wheels and the ground when the car takes a curve of 15 m radius towards right at 30 km/hr, taking into consideration the gyroscopic and the centrifugal effects. Each wheel radius is 400mm. [16M]
- 3 a) Derive the expression for the torque transmitting capacity of a single plate clutch by considering uniform pressure. [6M]  
 b) An effective diameter of the cone clutch is 75 mm. The semi-angle of the cone is  $18^\circ$ . Find the torque required to produce slipping of the clutch if an axial force applied is 200 N. This clutch is employed to connect an electric motor running uniformly at 100 r.p.m with a flywheel which is initially stationary. The flywheel has a mass of 13.5 kg and its radius of gyration is 150 mm. Calculate the time required for the flywheel to attain full speed, and also the energy lost in the slipping of the clutch. Take coefficient of friction as 0.3. [10M]
- 4 a) Draw the turning moment diagrams for the following different types of engines, neglecting the effect of inertia of the connecting rod: 1. Single cylinder double acting steam engine 2. Four stroke cycle. I.C. engine [8M]



- b) A Punching press is driven by a constant torque electric motor. The press is provided with a flywheel that rotates at maximum speed of 225 rpm. The radius of gyration of the flywheel is 0.5m. The press punches 720 holes per hour, each punching operation takes 2 seconds and requires 15 kN-m of energy. Find the power of the motor and minimum mass of the flywheel if speed of the same is not to fall below 200 rpm? [8M]
- 5 The arms of a Proell governor are 30 cm long. The upper arms are pivoted on the axis of rotation, while the lower arms are pivoted at a radius of 4 cms. Each ball weighs 5 kgf and is attached to an extension 10 cm long of the lower arm, the central weight is 60 kgf. At the minimum radius of 16 cm the extension to which balls are attached are parallel to the governor axis. Find the equilibrium speed corresponding to a radius of 16 cms. [16M]
- 6 Two weights of 8 kg and 16 kg rotate in the same plane at radii of 1.5 and 2.25 m respectively. The radii of these weights are  $60^\circ$  apart. Find the position of the third weight of the magnitude of 12 kg in the same plane which can produce static balance of the system. [16M]
- 7 a) Prove, from first principles, that with viscous damping, the amplitudes of successive oscillations are in geometric progression in the case of free damped vibration. [8M]
- b) A shaft of 100 mm diameter and 1 m long is fixed at one end, and the other end carries a flywheel of mass 1 tonne. The radius of gyration of the flywheel is 0.5 m. Find the frequency of torsional vibrations, if the modulus of rigidity of the shaft material is  $80 \text{ GN/m}^2$ ? [8M]

\*\*\*\*\*



**III B. Tech I Semester Regular/Supplementary Examinations, October/November- 2017**

**DYNAMICS OF MACHINERY**

(Common to Mechanical Engineering and Auto Mobile Engineering)

Time: 3 hours

Max. Marks: 70

- Note: 1. Question Paper consists of two parts (**Part-A** and **Part-B**)  
 2. Answering the question in **Part-A** is compulsory  
 3. Answer any **THREE** Questions from **Part-B**

**PART -A**

- 1 a) Write about Bow and Stern terms used in connection with the movement of a natural ship. [3M]  
 b) Define angle of friction? [4M]  
 c) Define angular velocity and angular acceleration? [4M]  
 d) Write about auxiliary springs. [3M]  
 e) What will be the harm if the rotating parts of high speed engine are not properly balanced? [4M]  
 f) Write about whirling of shafts? [4M]

**PART -B**

- 2 The rotor of a turbine installed in a boat with its axis along the longitudinal axis of the boat makes 1500 rpm clockwise when viewed from the stern. The rotor has a mass of 750 kg and a radius of gyration of 300mm. If at an instant, the boat pitches in the longitudinal vertical plane so that bow rises from the horizontal plane with an angular velocity of 1 rad/s, determine the torque acting in the boat and the direction in which it tends to turn the boat at the instant. [16M]
- 3 a) Name different types of dynamometers. Explain function of prony brake. [8M]  
 b) A clutch has disk plates with outer radius 120 mm. Axial force of 5kN is acting on them. The disc plates are new and have coefficient of friction 0.65. Assume uniform pressure and uniform wear, find the torque transmitted. When the disc plates are solid. [8M]
- 4 A machine has to carry out punching operation at the rate of 10 holes per minute. It does 6 kN-m of work per mm<sup>2</sup> of the sheared area on cutting 25 mm diameter holes in 20mm thick plates. A flywheel is fitted to the machine shaft which is driven by a constant torque. The fluctuation of speed is between 180 and 200 rpm. The actual punching takes 1.5 seconds. The frictional losses are equivalent to 1/6 of the work done during punching. Find: i) power required to drive the punching machine, and ii) Mass of the flywheel, if the radius of gyration of the wheel is 0.5m. [16M]



- 5 In a Porter governor, the arms and links are each 25 cms long and intersect on main axis. Each ball weighs 3kgf and the central load 27.25 kgf. The sleeve is in the lowest position when the arms are inclined at  $27^0$  with the axis. The lift of the sleeve is 5 cm. What is the force of the friction at the sleeve if the speed at the beginning of ascent at the lowest position is equal to the speed at the beginning of descent from the highest position? [16M]
- 6 A four coupled-wheel locomotive with two inside cylinders has reciprocating and revolving parts per cylinder as 300 kgf and 250 kgf respectively. The distance between planes of driving wheels is 150 cms. The pitch of cylinders is 60cms. The diameter of tread and driving wheels is 190 cms and the distance between planes of coupling rod cranks in 190 cms. The revolving parts for each coupling rod crank are 125 kgf. The angle between engine cranks is  $90^0$  and the length of coupling rod crank 22 cms. The angle made by coupling rod crank with adjustment crank is 180. The distance of center of gravity of balance weights in planes of driving wheels from a scale center is 75 cms. Crank radius is 32 cms. Determine: (i) The magnitude and position of balance weights required in leading and trailing wheels to balance  $2/3$  of reciprocating and whole of revolving parts if half of the required reciprocating parts are to be balanced in each pair of coupled wheels. (ii) The maximum variation of tractive force and hammer blow when locomotive speed is 100kmph. [16M]
- 7 a) Explain about free vibration of spring mass system? [6M]
- b) A shaft 50mm diameter and 3m long. It is simply supported at the ends and carries three masses 100Kg, 120Kg and 80Kg at 1.0m, 1.75m and 2.5m respectively from the left support. Taking  $E=20GN/m^2$ . Find the frequency of transverse vibrations using Rayleigh's method. [10M]

\*\*\*\*\*



**III B. Tech I Semester Regular/Supplementary Examinations, October/November - 2016**

**DYNAMICS OF MACHINERY**

(Comm. to ME and AME)

Time: 3 hours

Max. Marks: 70

- Note: 1. Question Paper consists of two parts (**Part-A** and **Part-B**)  
 2. Answering the question in **Part-A** is compulsory  
 3. Answer any **THREE** Questions from **Part-B**
- ~~~~~

**PART -A**

- |      |  |      |
|------|--|------|
| 1 a) | Explain what do you understand by gyroscopic stabilization                           | [3M] |
| b)   | State the laws of (i) Solid friction (ii) Dynamic friction and (iii) Fluid friction. | [3M] |
| c)   | What do you mean by fluctuation of energy and fluctuation of speed of crank shaft    | [3M] |
| d)   | What is the function of a governor? How does it differ from that of flywheel?        | [4M] |
| e)   | Explain the terms "primary and secondary distributing force"                         | [5M] |
| f)   | What do you mean by torsionally equivalent shaft?                                    | [4M] |

**PART -B**

- |      |   |       |
|------|---|-------|
| 2    | The turbine rotor of a ship has a mass of 20 tonnes and a radius of gyration of 0.75 m. Its speed is 2000 r.p.m. The ship pitches 6° above and below the horizontal position. One complete oscillation takes 18 seconds and the motion is simple harmonic. Determine (a) the maximum couple tending to shear the holding down bolts of the turbine. (b) The maximum angular acceleration of the ship during pitching and (c) The direction in which the bow will tend to turn while rising, if the rotation of the rotor is clockwise when looking from rear. | [16M] |
| 3 a) | A conical pivot bearing 150 mm in diameter has a cone angle of 120°. If the shaft supports an axial load of 20 kN and the coefficient of friction is 0.03, find the power lost in friction when the shaft rotates at 200 rpm, assuming uniform pressure and uniform wear.   | [8M]  |
| b)   | Determine the axial force required to engage a cone clutch transmitting 25 kw of power at 750 rpm. Average friction diameter of the cone is 400 mm, and the average pressure intensity is 60kN/m <sup>2</sup> . Semi cone angle is 10° and the coefficient of friction is 0.25.   | [8M]  |
| 4    | The turning moment diagram for a petrol engine is drawn to vertical scale of 1mm to 6 N-m, and a horizontal scale of 1 mm to 1°. The turning moment repeats itself after every half revolution of the engine. The areas above and below the mean torque line are 305, 710, 50, 350, 980, and 275 mm <sup>2</sup> . The rotating parts amount to a mass of 40 kg at a radius of gyration of 140 mm. Calculate the co-efficient of fluctuation of speed if the speed of engine is 1500 rpm.   | [16M] |



- 5 a) State the different methods to determine the equilibrium speed of a Porter Governor. [6M]
- b) A Porter governor has arms 250 mm each and four rotating fly balls of mass 0.8 kg each the sleeve movement is restricted to  $\pm 20$  mm from the height when the mean speed is 100 rpm calculate the central dead load and sensitivity of the governor neglecting friction when the fly ball exerts the centrifugal force of 9.81 N. Determine also the effort and power of the governor for 1% speed change [10M]
- 6 a) Explain the terms: variation of tractive force, swaying couple, and hammer blow. [6M]
- b) Each crank of a four cylinder vertical engine is 225 mm. The reciprocating masses of the first, second and the third cranks are 100 kg, 120 kg and 100 kg and the planes of rotation are 600 mm, 300 mm and 300 mm from the plane of rotation of the third crank. Determine the mass of the reciprocating parts of the third cylinder and the relative angular positions of the cranks if the engine is in complete primary balance. [10M]
- 7 a) Discuss briefly with neat sketches the longitudinal transverse and torsional free vibrations. [6M]
- b) A vibrating system consists of a mass of 10 kg, spring stiffness 12 N/mm and a dash pot of damping coefficient of 0.06 N/mm/sec. [10M]
- i.** damping factor, **ii.** logarithmic decrement and  
**iii.** ratio of the two consecutive amplitudes

\*\*\*\*\*



**III B. Tech I Semester Regular/Supplementary Examinations, October/November - 2016****DYNAMICS OF MACHINERY**

(Comm. to ME and AME)

Time: 3 hours

Max. Marks: 70

- Note: 1. Question Paper consists of two parts (**Part-A** and **Part-B**)  
 2. Answering the question in **Part-A** is compulsory  
 3. Answer any **THREE** Questions from **Part-B**
- ~~~~~

**PART -A**

- 1 a) State the three useful applications of the gyroscopic action. [3M]
- b) What is a Wedge? Explain how wedge is useful to raise the heavy loads. [4M]
- c) What is the function of fly wheel in a prime mover? [3M]
- d) What is meant by the term, stability of a governor? [4M]
- e) Define the terms Swaying couple and hammer blow. [4M]
- f) Explain magnification factor. [4M]

**PART -B**

- 2 A four wheeled motor car of mass 2000 kg has a wheel base 2.5 m, track width 1.5 m and height of center of gravity 500 mm above the ground level and lies at 1 m from the front axle. Each wheel has an effective diameter of 0.8 m and a moment of inertia of  $0.8 \text{ kg-m}^2$ . The drive shaft, engine flywheel and transmission are rotating at 4 times the speed of road wheel, in a clockwise direction when viewed from the front, and is equivalent to a mass of 75 kg having a radius of gyration of 100 mm. If the car is taking a right turn of 60 m radius at 60 km/h, find the load on each wheel. [16M]
- 3 a) Determine the axial force required to engage a cone clutch transmitting 25 kW of power at 750 rpm. Average friction diameter of the cone is 400 mm, semi cone angle  $10^\circ$  and coefficient of friction 0.25. Also find the width of the friction cone. [8M]
- b) Describe with a neat sketch the method of operation of rope brake dynamometer. [8M]
- 4 The equation of a turning moment curve at a three crank engine is  $2500 + 750 \sin 3\theta$  N m where  $\theta$  is the crank angle in radians. The mean speed of the engine is 240 rpm. The flywheel and other rotating parts attached to the engine have a mass of 500 kg at a radius of gyration of 1m calculate [16M]
  - (i) the power of the engine
  - (ii) total fluctuation of the speed of the flywheel in percentage when the resisting torque is constant.
- 5 a) State the different methods to determine the equilibrium speed of a Porter governor [6M]
- b) A Porter governor has arms 250 mm each and four rotating fly balls of mass 0.8kg each the sleeve movement is restricted to 20 mm from the height when the mean speed is 100 rpm. Calculate the central dead load and sensitivity of the governor neglecting friction when the fly ball exerts the centrifugal force of 9.81 N. Determine also the effort and power of the governor for 1% speed change [10M]



- 6 a) Prove the relation that Hammer blow =  $\pm m_b \times r^* \times \omega^2$  [8M]  
where  $m_b$  = Balancing mass placed at a radius of  $r^*$  and  $\omega$  = angular speed of the crank.
- b) Three masses of 8 kg, 12 kg, and 15 kg attached at radial distances of 80, 100, and 60 mm respectively to a disc on a shaft are in complete balance. Determine the angular positions of the masses of 12 kg and 15 kg relative to the 8 kg mass. [8M]
- 7 a) Define the term of Whirling speed of shaft [4M]
- b) A coil of spring stiffness 60 N/mm supports vertically a load of 3 kN at the free end. [12M]  
The motion is resisted by the oil dashpot. It is found that the amplitude at the beginning of the fourth cycle is 0.6 times the amplitude of the previous vibration. Find the ratio of the frequencies of damped and un damped vibrations.

\*\*\*\*\*



**III B. Tech I Semester Regular/Supplementary Examinations, October/November - 2016**

**DYNAMICS OF MACHINERY**

(Comm. to ME and AME)

Time: 3 hours

Max. Marks: 70

Note: 1. Question Paper consists of two parts (**Part-A** and **Part-B**)  
 2. Answering the question in **Part-A** is compulsory  
 3. Answer any **THREE** Questions from **Part-B**

~~~~~

**PART -A**

- |      |                                                                            |      |
|------|----------------------------------------------------------------------------|------|
| 1 a) | Explain the terms spin and precession. How do they differ from each other? | [3M] |
| b)   | What is the difference between the simple and differential band brake?     | [4M] |
| c)   | What is turning movement diagram? Mention its uses.                        | [3M] |
| d)   | Explain the terms: Sensitiveness and Stability                             | [3M] |
| e)   | Explain the term partial balancing of primary force. Why it is necessary?  | [5M] |
| f)   | What do you mean by logarithmic decrement?                                 | [4M] |

**PART -B**

- |      |                                                                                                                                                                                                                                                                                                                                                                                                                                                                                                                                                                                                                                                                                      |       |
|------|--------------------------------------------------------------------------------------------------------------------------------------------------------------------------------------------------------------------------------------------------------------------------------------------------------------------------------------------------------------------------------------------------------------------------------------------------------------------------------------------------------------------------------------------------------------------------------------------------------------------------------------------------------------------------------------|-------|
| 2 a) | Explain gyroscopic effects on four wheels.                                                                                                                                                                                                                                                                                                                                                                                                                                                                                                                                                                                                                                           | [4M]  |
| b)   | A gear engine automobile is traveling along a curved track of 120m radius. Each of the four wheels has a moment of inertia of $2.3 \text{ kg m}^2$ and an effective diameter of 600 mm. The rotating parts of the engine have a moment of inertia of $1.25 \text{ kg m}^2$ the gear ratio of the engine to back wheel is 3:2. The engine axis is parallel to the gear axle and the crank shaft rotates in the same sense as the road wheels. The mass of the vehicle is 2050 kg and the center of mass is 520 mm above the road level. The width by the track is 1.6m, what will be the limiting speed of the vehicle if all the four wheels maintain contact with the road surface. | [12M] |
| 3 a) | A flat foot step bearing 300mm in diameter supports a load of 8kN. If the coefficient of friction is 0.1, and the speed of the shaft is 80 rpm, find the power lost in friction, assuming uniform wear.                                                                                                                                                                                                                                                                                                                                                                                                                                                                              | [8M]  |
| b)   | A torsion dynamometer is fitted on a turbine shaft to measure the angle of twist. It is observed that the shaft twists $2^\circ$ in a length of 5 m at 600 rpm. The shaft is solid and has a diameter of 250 mm. If the modulus of rigidity is 84 GPa, find the power transmitted by the turbine.                                                                                                                                                                                                                                                                                                                                                                                    | [8M]  |
| 4 a) | Explain the function of a flywheel from a crank effort diagram.                                                                                                                                                                                                                                                                                                                                                                                                                                                                                                                                                                                                                      | [6M]  |
| b)   | In a reciprocating engine, length of stroke is 30 cm and connecting rod is 60 cm long between centres. When the piston has travelled 8 cm from the inner dead centre, find<br>i) angular position of the crank ; ii) velocity and acceleration of the piston ;<br>iii) angular velocity of connecting rod, if the engine speed is 240 rpm.                                                                                                                                                                                                                                                                                                                                           | [10M] |



- 5 a) What is meant by the term, stability of a governor? Derive the necessary conditions of stability for a centrifugal governor. [6M]
- b) For a spring controlled Hartnell type governor, following data is provided: mass of the governor ball is 2 kg, length of the vertical arm of bell crank lever is 800 mm, and length of the other arm of bell crank lever is 90 mm. The speeds corresponding to radii of rotations 120 mm and 130 mm are 300 rpm and 310 rpm respectively. Determine the stiffness of spring. [10M]
- 6 a) Four masses  $m_1, m_2, m_3$  and  $m_4$  having 100, 175, 200, and 25kg fixed to cranks of 20cm radius and revolve in places 1, 2, 3 and 4. The angular position of the cranks in planes 2, 3 and 4 with respect to the crank in plane 1 are 75° same sense. The distances of planes 2, 3 and 4 from plane 1 are 60cm, 186cm and 240cm respectively. Determine the position and magnitude of the balance mass at a radius of 60cm in plane L and M located at the middle of the plane 1 and 2 and the middle of the planes 3 and 4 respectively. [12M]
- b) Describe reasons for partial balancing of reciprocating masses. [4M]
- 7 a) Discuss the effect of inertia of the shaft in longitudinal and transverse vibrations. [6M]
- b) A shaft 40 mm diameter and 2.5 m long has a mass of 15 kg/m length. It is simply supported at the ends and carries three masses 90 kg, 140 kg and 60 kg at 0.8 m, 1.5 m and 2 m respectively from the left support. Taking  $E = 20 \text{ GN/m}^2$ . Find the frequency of transverse vibrations [10M]

\*\*\*\*\*



**III B. Tech I Semester Regular/Supplementary Examinations, October/November - 2016****DYNAMICS OF MACHINERY**

(Comm. to ME and AME)

Time: 3 hours

Max. Marks: 70

Note: 1. Question Paper consists of two parts (**Part-A** and **Part-B**)  
 2. Answering the question in **Part-A** is compulsory  
 3. Answer any **THREE** Questions from **Part-B**

**PART -A**

- 1 a) What is the principle of gyroscope? [3M]
- b) State the laws of static and dynamic friction [4M]
- c) What do you mean by resisting torque? What are the conditions for fly wheel to accelerate and retard? [4M]
- d) Compare the functions of a fly wheel and a governor. [4M]
- e) What do you mean by static balancing and dynamic balancing? [3M]
- f) What do you mean by over, under and critical damping systems? [4M]

**PART -B**

- 2 a) Derive an expression for gyroscopic couple in standard form. [6M]
- b) A ship is propelled by a turbine rotor which weighs 5 KN and rotates at a speed of 2100 rpm. The rotor has radius of gyration of 50 cm and rotates clockwise when viewed from stern. Find the gyroscopic effects in each of the following cases. [10M]
  - i) The ship turns to the left at a speed of 8.3m/sec
  - ii) The ship pitches so that the bow rises from the horizontal plane with an angular velocity of 1 rad/sec.
- 3 a) Derive an expression for the effort to be applied on a body for moving it down the rough inclined plane when effort applied is horizontal. [8M]
- b) A simple band brake is operated by a lever of length 500 mm. The brake drum has a diameter of 500 mm and the brake band embraces 5/8 of the circumference. One end of the band is attached to the fulcrum of the lever while the other end is attached to a pin on the lever 100 mm from the fulcrum. If the effort applied to the end of the lever is 2 kN and the coefficient of friction is 0.25, find the maximum braking torque on the drum. [8M]
- 4 The turning moment diagram for the engine is drawn to the following scales: [16M]  
 Turning moment, 1 mm = 1000 N-m, and for crank angle is 1 mm = 6°. The areas above and below the mean turning moment line taken in order are: 530, 330, 380, 470, 180, 360, 350, 280 mm<sup>2</sup>. The mean speed of the engine is 150 rpm and the total fluctuation of speed must not exceed 3.5% of mean speed. Determine the diameter and mass of the flywheel rim, assuming that total energy of the flywheel is to be 15/14 that of rim. The peripheral velocity of the flywheel is 15 m/s. Find also the suitable cross sectional area of the rim of the flywheel. Take density of the rim material as 7200 kg/m<sup>3</sup>



- 5 In a Proell governor, each ball weighs 2.5 kg; length of each of the main four arms in 20cms, the extended arm is 8 cm long. The pin joints of the main arm are 4 cm from the axis of the governor. For the sleeve to be on its bottom stop the distance between the top and bottom hinge points of the main arms is 30 cm and then the extended arm is vertical. Find the weight of central load when the sleeve just leaves the bottom stop at 150 rpm. What will be the speed of the governor after the sleeve has been raised to 4 cm? [16M]
- 6 A rotating shaft carries four radial masses A = 8 kg, B = C = 6 kg, and D = 5 kg. The mass centers are 30 mm, 40 mm, 40 mm, and 50 mm respectively from the axis of the shaft. The axial distance between the planes of rotation of A and B is 400mm, and that between B and C is 500 mm. The masses A and C are at right angles to each other. Find for a complete balance, (a) the angle between the masses B and D from mass A, (b) the axial distance between the planes of rotation of C and D, and (c) the magnitude of mass B. [16M]
- 7 A machine weighing 180 N is mounted on springs and dash pots. The equivalent stiffness of the spring is 88 N/cm and the equivalent damping is 1.2 Ns/cm. If the system is initially at rest and a velocity of 10cm/sec is imparted to the mass, determine, [16M]  
i) The displacement and velocity of the mass as a function of time  
ii) The displacement at time equal to 1 sec.

\*\*\*\*\*



**III B. Tech I Semester Supplementary Examinations, May - 2016**  
**DYNAMICS OF MACHINERY**  
(Common to ME and AME)

Time: 3 hours

Max. Marks: 70

- Note: 1. Question Paper consists of two parts (**Part-A** and **Part-B**)  
2. Answering the question in **Part-A** is compulsory  
3. Answer any **THREE** Questions from **Part-B**

\*\*\*\*\*

**PART -A**

- 1 a) Explain the gyroscopic effect on four wheeled vehicles. [4M]
- b) Explain about film lubrication. [4M]
- c) Explain the terms 'fluctuation of energy' and 'fluctuation of speed' as applied to flywheels. [3M]
- d) Define and explain "Isochronism" relating to governors. [4M]
- e) Write a short note on primary balancing. [4M]
- f) What are the causes and effects of vibrations? [3M]

**PART -B**

- 2 a) Write a short note on gyroscope. [6M]
- b) The turbine rotor of a ship has a mass of 3500 kg. It has a radius of gyration of 0.45 m and a speed of 3000 rpm clockwise when looking from stern. Determine the gyroscopic couple and its effect upon the ship. [10M]
  - (i) when the ship is steering to the left on a curve of 100 m radius at a speed of 36 km/h.
  - (ii) when the ship is pitching in a simple harmonic motion, the bow falling with its maximum velocity. The period of pitching is 40 seconds and the total angular displacement between the two extreme positions of pitching is 12 degrees.
- 3 a) What is meant by the expression 'friction circle'? Deduce an expression for the radius of friction circle in terms of the radius of the journal and the angle of friction. [8M]



- b) The essential features of a transmission dynamometer are shown in Fig.1. A is the driving pulley which runs at 600 r.p.m. B and C are jockey pulleys mounted on a horizontal beam pivoted at D, about which point the complete beam is balanced when at rest. E is the driven pulley and all portions of the belt between the pulleys are vertical. A, B and C are each 300 mm diameter and the thickness and weight of the belt are neglected. The length DF is 750 mm. Find i) the value of the weight W to maintain the beam in a horizontal position when 4.5 kW is being transmitted and ii) the value of W, when the belt just begins to slip on pulley A. The coefficient of friction being 0.2 and maximum tension in the belt 1.5 kN. [8M]

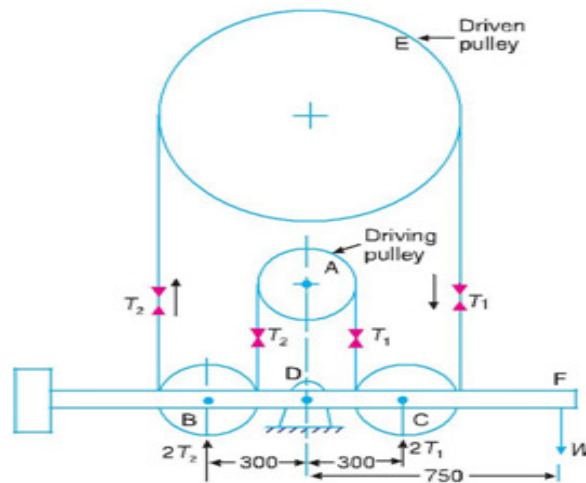

All dimensions are in mm

Fig.1

- 4 a) Discuss the method of finding the crank effort in a reciprocating single acting, single cylinder petrol engine. [8M]  
 b) The connecting rod of a gasoline engine is 300 mm long between its centres. It has a mass of 15 kg and mass moment of inertia of  $7000 \text{ kg}\cdot\text{mm}^2$ . Its centre of gravity is at 200 mm from its small end centre. Determine the dynamical equivalent two-mass system of the connecting rod if one of the masses is located at the small end centre. [8M]
- 5 a) State the different types of governors. Explain about any one of them. [8M]  
 b) The following particulars refer to a Wilson-Hartnell governor: [8M]  
 Mass of each ball = 2 kg ; minimum radius = 125 mm ; maximum radius = 175 mm ; minimum speed = 240 rpm ; maximum speed = 250 rpm ; length of the ball arm of each bell crank lever = 150 mm; length of the sleeve arm of each bell crank lever = 100 mm ; combined stiffness of the two ball springs = 0.2 kN/m. Find the equivalent stiffness of the auxiliary spring referred to the sleeve.

- 6 a) Discuss how a single revolving mass is balanced by two masses revolving in different planes. [7M]
- b) The following data refer to two cylinder locomotive with cranks at  $90^\circ$ : [9M]  
Reciprocating mass per cylinder = 300 kg ; Crank radius = 0.3 m ; Driving wheel diameter = 1.8 m ; Distance between cylinder centre lines = 0.65 m ; Distance between the driving wheel central planes = 1.55 m.  
Determine i) the fraction of the reciprocating masses to be balanced, if the hammer blow is not to exceed 46 kN at 96.5 kmph,  
ii) the variation in tractive effort and  
iii) the maximum swaying couple.
- 7 a) Discuss briefly with neat sketches the longitudinal, transverse and torsional free vibrations. [8M]
- b) A shaft, 1.5 m long, supported by flexible bearings at the ends carries two wheels each of 50 kg mass. One wheel is situated at the centre of the shaft and the other at a distance of 375 mm from the centre towards left. The shaft is hollow of external diameter 75 mm and internal diameter 40 mm. The density of the shaft material is  $7700 \text{ kg/m}^3$  and its modulus of elasticity is  $200 \text{ GN/m}^2$ . Find the lowest whirling speed of the shaft, taking into account the mass of the shaft. [8M]

\*\*\*\*\*



**III B. Tech I Semester Supplementary Examinations, May - 2018**  
**DYNAMICS OF MACHINERY**

(Common to Mechanical Engineering and Automobile Engineering)

Time: 3 hours

Max. Marks: 70

- Note: 1. Question Paper consists of two parts (**Part-A** and **Part-B**)  
 2. Answering the question in **Part-A** is compulsory  
 3. Answer any **THREE** Questions from **Part-B**

**PART -A**

- |   |    |                                    |      |
|---|----|------------------------------------|------|
| 1 | a) | What is the function of Gyroscope? | [4M] |
|   | b) | List the types of clutches?        | [4M] |
|   | c) | Define crank effort?               | [3M] |
|   | d) | Write about isochronism?           | [4M] |
|   | e) | Write about swaying couple?        | [4M] |
|   | f) | Explain about vibration isolation? | [3M] |

**PART -B**

- |   |    |                                                                                                                                                                                                                                                                                                                                                                                                                                                                                                                                            |       |
|---|----|--------------------------------------------------------------------------------------------------------------------------------------------------------------------------------------------------------------------------------------------------------------------------------------------------------------------------------------------------------------------------------------------------------------------------------------------------------------------------------------------------------------------------------------------|-------|
| 2 | a) | An aeroplane makes a complete half circle radius towards left when flying at 210 km/h. The rotary engine and the plane is of 50 kg mass having a radius of gyration of 300 mm. The engine rotates at 2400 rpm clockwise as seen from the rear. Find the gyroscopic couple on the aircraft and its effect on the plane.                                                                                                                                                                                                                     | [8M]  |
|   | b) | Explain the working of a Gyroscope along with an example of its use and give its merits and demerits                                                                                                                                                                                                                                                                                                                                                                                                                                       | [8M]  |
| 3 | a) | A single plate clutch having both sides effective is required to transmit 45 kW at 1500 rpm. The outer diameter of the plate is limited to 300 mm and the intensity of pressure between the plates is not to exceed 0.07 MPa. Assuming uniform wear and a coefficient of friction 0.35, determine the inside diameter of the plate?                                                                                                                                                                                                        | [9M]  |
|   | b) | Explain about boundary friction and film lubrication?                                                                                                                                                                                                                                                                                                                                                                                                                                                                                      | [7M]  |
| 4 | a) | The torque exerted on the crank shaft of a two stroke engine is given by the equation $T=(14,500+2,300\sin 2\theta-1,900\cos 2\theta)$ N-m where $\theta$ is the angle moved by the crank from I.D.C. If the resisting torque is constant find:<br>i) The power of the engine, when the speed is 150rpm.<br>ii) The moment of inertia of the flywheel if the speed variation is not to exceed $\pm 0.5\%$ of the mean speed.<br>iii) The angular acceleration of the flywheel when the crank has turned through $30^\circ$ from the I.D.C. | [10M] |
|   | b) | Explain about coefficient of fluctuation of speed and coefficient of fluctuation of energy.                                                                                                                                                                                                                                                                                                                                                                                                                                                | [6M]  |



- 5 In a spring loaded Hartnell type of governor, the mass of each ball is 4kg and the lift of the sleeve is 50mm. The governor begins to float at 240rpm, when radius of the ball path is 110mm. The mean working speed of the governor is 20 times the range of the speed when friction is neglected. The lengths of the ball and roller arms of the bell-crank lever are 120mm and 100mm respectively. The pivot centre and the axis of governor are 140mm apart. Determine the initial compression of the spring, taking in to consideration of arms. [16M]
- 6 A three cylinder radial engine driven by a common crank has the cylinders spaced at  $120^\circ$ . The stroke is 100 mm, length of the connecting rod 200 mm and the reciprocating mass per cylinder 1.5 kg. Calculate the primary and secondary forces at crank shaft speed of 1500 r.p.m. [16M]
- 7 a) Explain the phenomenon of the whirling of shafts. [6M]  
b) Derive an expression for logarithmic decrement in damped free vibration of a mechanical system? [10M]

\*\*\*\*\*



**III B. Tech I Semester Regular Examinations, November - 2015**  
**DYNAMICS OF MACHINERY**  
 (Common to ME and AME)

Time: 3 hours

Max. Marks: 70

- Note: 1. Question Paper consists of two parts (**Part-A** and **Part-B**)  
 2. Answering the question in **Part-A** is compulsory  
 3. Answer any **THREE** Questions from **Part-B**

\*\*\*\*\*

**PART -A**

- |   |                                                                     |      |
|---|---------------------------------------------------------------------|------|
| 1 | a) What is gyroscopic torque?                                       | [4M] |
|   | b) What is meant by expression friction circle?                     | [4M] |
|   | c) What is meant by turning moment diagram or crank effort diagram? | [4M] |
|   | d) What is the function of governor?                                | [4M] |
|   | e) What is meant by balancing of rotating masses?                   | [3M] |
|   | f) What are the causes and effect of vibration?                     | [3M] |

**PART -B**

- 2 The turbine rotor of a ship has a mass of 20 tones and a radius of gyration 0.75. Its speed is 2000 rpm. The ship pitches  $6^\circ$  above and below the horizontal position .One complete oscillation takes 18 seconds and the motion is simple harmonic. Determine [16M]
- (i) the maximum couple tending to shear the holding down bolt of the turbine
- (ii) The maximum angular acceleration of the ship during pitching. The direction in which the bow will tend to turn while, if the rotation of the rotor is clockwise when looking from rear.
- 3 a) Which of the two assumptions-uniform intensity of pressure or uniform rate of wear, would you make use of in designing friction clutch and why? [8M]
- b) A cone clutch with cone angle  $20^\circ$  is to transmit 7.5 kW at 750 rpm. The normal intensity of pressure between the contact faces is not to exceed  $0.12\text{N/mm}^2$ . The coefficient of friction is 0.2. If face width is  $1/5^{\text{th}}$  of mean diameter, find: [8M]
- (i) The main dimensions of the clutch and
- (ii) Axial force required while running.
- 4 The turning moment diagram for a four stroke gas engine may be assumed for simplicity to be represented by four triangles, the areas of which from the line of zero pressure are as follows: Expansion stroke =  $3550\text{ mm}^2$ ; Exhaust stroke =  $500\text{ mm}^2$ ; Suction stroke =  $350\text{ mm}^2$ ; and compression stroke =  $1400\text{ mm}^2$ . each  $\text{mm}^2$  represents 3 N-m. Assuming the resisting moment to be uniform, find the mass of the rim of a fly wheel required to keep the mean speed 200 rpm within  $\pm 2\%$ . The mean radius of the rim may be taken as 0.75 m. Also determine the crank positions for the maximum and minimum speeds. [16M]



- 5 The lengths of the upper and lower arms of a porter governor are 200mm and 250mm respectively. Both the arms are pivoted on the axis of rotation. The central load is 150N, the weight of the each ball is 20N and the friction of the sleeve together with the resistance of the operating gear is equivalent to a force of 30N at the sleeve. If the limiting inclinations of the upper arms to the vertical are  $30^\circ$  and  $40^\circ$  taking friction in to account. Find the range of speed of the governor. [16M]
- 6 Four masses  $M_1$ ,  $M_2$ ,  $M_3$  and  $M_4$  are 200kg, 300kg, 240kg and 260kg respectively. The corresponding radii of rotation are 0.2m, 0.15m, 0.25m and 0.3m respectively and the angle between successive masses are  $45^\circ$ ,  $75^\circ$  and  $135^\circ$ . Find the position and magnitude of balance mass required if its radius of rotation is 0.25m. [16M]
- 7 In a single degree of damped vibration system a suspended mass of 8kg makes 30 oscillations in 18 seconds. The amplitude decreases in 18 seconds. The amplitude decreases to 0.25 of the initial value after 5 oscillations. Determine
- (i) the spring stiffness
  - (ii) logarithmic decrement
  - (iii) damping factor
  - (iv) Damping coefficient.

(4M+4M+4M+4M)

**-000-**

**III B. Tech I Semester Regular Examinations, November - 2015**  
**DYNAMICS OF MACHINERY**  
 (Common to ME and AME)

Time: 3 hours

Max. Marks: 70

- Note: 1. Question Paper consists of two parts (**Part-A** and **Part-B**)  
 2. Answering the question in **Part-A** is compulsory  
 3. Answer any **THREE** Questions from **Part-B**

\*\*\*\*\*

**PART -A**

- |   |                                                                                      |      |
|---|--------------------------------------------------------------------------------------|------|
| 1 | a) What is the effect of gyroscopic couple on rolling of ship? Why?                  | [4M] |
|   | b) What is friction? Is it a blessing or curse? Justify your answer giving examples? | [4M] |
|   | c) Why flywheels are needed in forging and pressing operations?                      | [4M] |
|   | d) How governors are classified?                                                     | [4M] |
|   | e) Why rotating masses are to be dynamically balanced?                               | [3M] |
|   | f) Define frequency, cycle, period and free vibration.                               | [3M] |

**PART -B**

- |   |                                                                                                                                                                                                                                                                                                                                                                                                                                                                                                                                                                                                                                                                                                                                                                   |              |
|---|-------------------------------------------------------------------------------------------------------------------------------------------------------------------------------------------------------------------------------------------------------------------------------------------------------------------------------------------------------------------------------------------------------------------------------------------------------------------------------------------------------------------------------------------------------------------------------------------------------------------------------------------------------------------------------------------------------------------------------------------------------------------|--------------|
| 2 | The rotor of a turbine yacht rotates at 1200rpm clockwise when viewed from stern. The rotor has a mass of 750 kg and radius of gyration of 250mm. Find the maximum gyroscopic couple transmitted to the hull when yacht pitches with a maximum angular velocity of 1 rad/s. What is the effect of this couple?                                                                                                                                                                                                                                                                                                                                                                                                                                                    | [16M]        |
| 3 | A band and block brake having 12 blocks, each of which subtends an angle of 160 at the centre, is applied to a rotating drum of diameter 600 mm. the blocks are 75 mm thick. The drum and the flywheel mounted on the same shaft have a mass of 1800kg and have a combined radius of gyration of 600mm. the two ends of the band are attached to pins on the opposite sides of the brake fulcrum at distance of 40 mm and 150mm from the fulcrum. If a force of 250 N is applied at a distance of 900 mm from the fulcrum, find (i) the maximum braking torque (ii) the angular retardation of the drum (iii) the time taken by the system to be stationary from the rated speed of 300 rpm. Take coefficient of friction between the blocks and the drum as 0.3. | [16M]        |
| 4 | Derive expression for<br>(a) Coefficient of steadiness<br>(b) Energy stored in flywheel.                                                                                                                                                                                                                                                                                                                                                                                                                                                                                                                                                                                                                                                                          | [8M]<br>[8M] |
| 5 | A porter governor has equal arms each 250mm long and pivoted on the axis of rotation. Each ball has a mass of 5kg and mass of the central load on the sleeve is 25kg. The radius of rotation of the ball is 150mm when governor is at maximum speed. Find the maximum and minimum speed and range of speed of the governor                                                                                                                                                                                                                                                                                                                                                                                                                                        | [16M]        |
| 6 | Four masses A, B, C and D revolves at equal radii and equally spaced along a shaft. The mass B is 7kg and the radii of C and D make angle s of 90° and 240° respectively with the radius of B. Find the Magnitude of masses A, C and D and angular position of A, so that the system may be completely balanced.                                                                                                                                                                                                                                                                                                                                                                                                                                                  | [16M]        |
| 7 | Derive an expression for the natural frequency of the free longitudinal vibration by<br>(i) Equilibrium method, (ii) Energy method, (iii) Rayleigh's method.                                                                                                                                                                                                                                                                                                                                                                                                                                                                                                                                                                                                      | [16M]        |



**III B. Tech I Semester Regular Examinations, November - 2015**  
**DYNAMICS OF MACHINERY**  
 (Common to ME and AME)

Time: 3 hours

Max. Marks: 70

- Note: 1. Question Paper consists of two parts (**Part-A** and **Part-B**)  
 2. Answering the question in **Part-A** is compulsory  
 3. Answer any **THREE** Questions from **Part-B**

\*\*\*\*\*

**PART -A**

- |   |                                                         |      |
|---|---------------------------------------------------------|------|
| 1 | a) Define gyroscopic couple                             | [4M] |
|   | b) Explain the terms: friction circle and friction axis | [4M] |
|   | c) Differentiate the function of flywheel and governor  | [4M] |
|   | d) Differentiate between governor and fly wheel         | [4M] |
|   | e) Define static balancing.                             | [3M] |
|   | f) What are the different types of vibrations?          | [3M] |

**PART -B**

- |   |                                                                                                                                                                                                                                                                                                                                                                                                                                                                 |       |
|---|-----------------------------------------------------------------------------------------------------------------------------------------------------------------------------------------------------------------------------------------------------------------------------------------------------------------------------------------------------------------------------------------------------------------------------------------------------------------|-------|
| 2 | Each paddle wheel of a steamer has a mass of 1600kg and a radius of gyration of 1.2m. The steamer turns to port in a circle of 160m radius at 24Km/hr. The speed of the paddle is 90 rpm. Find the magnitude and effect of the gyroscopic couple acting on the steamer.                                                                                                                                                                                         | [16M] |
| 3 | a) Describe with a neat sketch the working of a single plate friction clutch.                                                                                                                                                                                                                                                                                                                                                                                   | [8M]  |
|   | b) Establish a formula for the maximum torque transmitted by a single plate clutch of external and internal radii $r_1$ and $r_2$ , if the limiting coefficient of friction is $\mu$ and the axial spring load is $W$ . Assume that the pressure intensity on the contact faces is uniform.                                                                                                                                                                     | [8M]  |
| 4 | a) What is meant by piston effort and crank effort?                                                                                                                                                                                                                                                                                                                                                                                                             | [8M]  |
|   | b) The crank of a three-cylinder single-acting engine is set equally at $120^\circ$ the engine speed is 540 rpm. The turning-moment diagram for each cylinder is a triangle for the power stroke with a maximum torque of 100 N-m at $60^\circ$ after dead- centre of the corresponding crank. On the return stroke, the torque is sensibly zero. Determine                                                                                                     | [8M]  |
|   | (i) The power developed                                                                                                                                                                                                                                                                                                                                                                                                                                         |       |
|   | (ii) The coefficient of fluctuation of speed if the flywheel has a mass of 7.5 kg with a radius of gyration of 65 mm                                                                                                                                                                                                                                                                                                                                            |       |
|   | (iii) The coefficient of fluctuation of energy and                                                                                                                                                                                                                                                                                                                                                                                                              |       |
|   | (iv) The maximum angular acceleration of the fly wheel.                                                                                                                                                                                                                                                                                                                                                                                                         |       |
| 5 | A hartnell governor having a central sleeve spring and two right angled bell crank lever operates between 290rpm and 310rpm for a sleeve lift of 15mm. The sleeve and ball arms are 80mm and 120mm respectively. The levers are pivoted at 120mm from the governor axis and mass of the ball is 2.5kg. The ball arms are parallel at lowest equilibrium speed. Determine (i) load on the spring at maximum and minimum speeds and (ii) Stiffness of the spring. | [16M] |



- 6 Derive the following expression of effects of partial balancing in two cylinder locomotive engine (i) Variation of tractive force, (ii) Swaying couple and (iii) Hammer blow. [16M]
- 7 a) A cantilever shaft 50mm diameter and 300mm long has a disc of mass 100kg at its free end. The Young's modulus for the shaft material is  $200\text{GN/m}^2$ . Determine the frequency of longitudinal and transverse vibration of the shaft. [8M]
- b) Explain, with sketches the different cases of damped vibrations. [8M]

**-000-**



**III B. Tech I Semester Regular Examinations, November - 2015**  
**DYNAMICS OF MACHINERY**  
 (Common to ME and AME)

Time: 3 hours

Max. Marks: 70

- Note: 1. Question Paper consists of two parts (**Part-A** and **Part-B**)  
 2. Answering the question in **Part-A** is compulsory  
 3. Answer any **THREE** Questions from **Part-B**

\*\*\*\*\*

**PART -A**

- 1 a) Write expression for gyroscopic couple. [4M]
- b) What is meant by uniform pressure theory or uniform wear theory for the friction torque of a bearing? [4M]
- c) List out the few machines in which flywheel are used. [4M]
- d) What is meant by sensitiveness of a governor? [4M]
- e) Define dynamic balancing [3M]
- f) State different methods of finding natural frequency of a system. [3M]

**PART -B**

- 2 a) Explain the effect of Gyroscopic couple on a Naval ship during pitching. [8M]
- b) Explain the effect of Gyroscopic couple on a Aeroplane. [8M]
- 3 a) A truncated conical pivot of cone angle  $\phi$  rotating at speed N supports a load W. The smallest and largest diameter of pivot over the contact area 'd' and 'D' respectively. Assuming uniform wear, derive the expression for frictional torque. [8M]
- b) A differential band brake, as shown in figure, below has an angle of contact of  $225^\circ$ . The band has a compressed woven lining and bears against a cast iron drum of 350 mm diameter. The brake is to sustain a torque of 350 N-m and the coefficient of friction between the band and the drum is 0.3. Find i) The necessary force (P) for the clockwise and anticlockwise rotation of the drum; and ii) The value of 'OA' for the brake to be self locking, when the drum rotates clockwise. [8M]

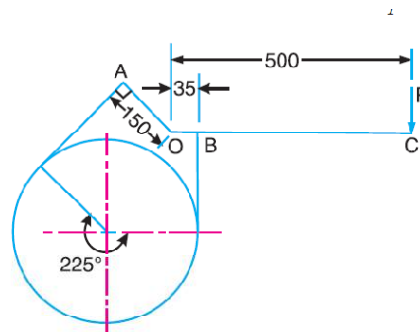

All dimensions in mm.



- 4 What is the function of a flywheel? How does it differ from that of a governor? [16M]  
The torque delivered by a two –stroke engine is represented by  $t = (1000 + 300 \sin 2\phi - 500 \cos 2\phi)$  N. m where  $\phi$  is the angle turned by the crank from the inner-dead centre. The engine speed is 250 rpm. The mass of the flywheel is 400 kg and radius of gyration is 400 mm. Determine (i) The power developed (ii) The total percentage fluctuation of speed (iii) The angular acceleration of flywheel when the crank has rotated through an angle of  $60^\circ$  from the inner-dead centre and (iv) The maximum angular acceleration and retardation of the flywheel.
- 5 Calculate the rage of speed of a porter governor which has equal arms of each 200mm long and pivoted on the axis of rotation. The mass of each ball is 4kg and the central load of the sleeve is 20kg. The radius of rotation of the ball is 100mm when the governor being to lift and 130mm when the governor is at maximum speed. [16M]
- 6 The data for three rotating masses are given below: [16M]  
 $M_1 = 4\text{kg}$                        $r_1 = 75\text{mm}$                        $\theta_1 = 45^\circ$   
 $M_2 = 3\text{kg}$                        $r_2 = 85\text{mm}$                        $\theta_2 = 135^\circ$   
 $M_3 = 2.5\text{kg}$                        $r_3 = 50\text{mm}$                        $\theta_3 = 240^\circ$   
Determine the amount of counter mass at a radial distance of 65mm required for their static balance.
- 7 A steel shaft 100mm in diameter is loaded and support in shaft bearing 0.4m apart. The shaft carries three loads: first mass 12kg at the centre, second mass 10kg at a distance 0.12m from the left bearing and third mass of 7kg at a distance 0.09m from the right bearing. Find the value of the critical speed by using Dunker ley's method if  $E = 2 \times 10^{11} \text{N/m}^2$ . [16M]

-000-

