

DIGITAL NOTES

Kinematics of Machinery **R18A0307**

B.Tech –II – I

DEPARTMENT OF MECHANICAL ENGINEERING



MALLA REDDY COLLEGE OF ENGINEERING & TECHNOLOGY

(An Autonomous Institution – UGC, Govt.of India)

Recognizes under 2(f) and 12(B) of UGC ACT 1956

**(Affiliated to JNTUH, Hyderabad, Approved by AICTE –Accredited by NBA & NAAC-“A” Grade-ISO 9001:2015
Certified)**

MALLA REDDY COLLEGE OF ENGINEERING & TECHNOLOGY

Department Of Mechanical Engineering,MRCET.

COURSE OBJECTIVES:

- Understand the fundamentals of the theory of kinematics and dynamics of machines.
- Understand techniques for studying motion of machines and their components.
- Use computer software packages in modern design of machines.

UNIT - I

Mechanisms : Elements or Links , Classification, Rigid Link, flexible and fluid link, Types of kinematic pairs , sliding, turning, rolling, screw and spherical pairs lower and higher pairs, closed and open pairs, constrained motion, completely, partially or successfully constrained and incompletely constrained .

Machines : Mechanism and machines, classification of machines, kinematic chain , inversion of mechanism, inversion of mechanism , inversions of quadric cycle, chain , single and double slider crank chains.

UNIT - II

Straight Line Motion Mechanisms: Exact and approximate copiers and generated types Peaucellier, Hart and Scott Russel Grasshopper Watt T. Chebicheff and Robert Mechanisms and straight line motion, Pantograph.

Steering Mechanisms: Conditions for correct steering Davis Steering gear, Ackermans steering gear velocity ratio.

Hooke's Joint: Single and double Hookes joint Universal coupling application problems.

UNIT - III

Kinematics: Velocity and acceleration - Motion of link in machine - Determination of Velocity and acceleration diagrams - Graphical method - Application of relative velocity method four bar chain.

Analysis of Mechanisms: Analysis of slider crank chain for displacement, velocity and acceleration of slider - Acceleration diagram for a given mechanism, Kleins construction, Coriolis acceleration, determination of Coriolis component of acceleration.

Plane motion of body: Instantaneous center of rotation, centroids and axodes – relative motion between two bodies - Three centres in line theorem - Graphical determination of instantaneous centre, diagrams for simple mechanisms and determination of angular velocity of points and links.

UNIT-IV

Cams: Definitions of cam and followers their uses Types of followers and cams Terminology Types of follower motion - Uniform velocity Simple harmonic motion and uniform acceleration. Maximum velocity and maximum acceleration during outward and return strokes in the above 3 cases.

Analysis of motion of followers: Roller follower circular cam with straight, concave and convex flanks.

UNIT - V:

Gears: Higher pairs, friction wheels and toothed gears types law of gearing, condition for constant velocity ratio for transmission of motion, Form of teeth: cycloidal and involute profiles. Velocity of sliding phenomena of interferences. Methods of interference. Condition for minimum number of teeth to avoid interference, expressions for arc of contact and path of contact - Introduction to Helical, Bevel and worm gearing.

Gear Trains: Introduction - Train value - Types - Simple and reverted wheel train Epicycle gear Train. Methods of finding train value or velocity ratio - Epicycle gear trains. Selection of gear box-Differential gear for an automobile.

COURSE OUTCOMES:

- Distinguish kinematic and kinetic motion. Identify the basic relations between distance, time velocity, and acceleration. Apply vector mechanics as a tool for solving kinematic problems. Create a schematic drawing of a real-world mechanism.
- Determine the degrees-of-freedom (mobility) of a mechanism. Use graphical and analytic methods to study the motion of a planar mechanism. Use computer software to study the motion of a mechanism. Design basic gear trains. Design basic cam systems.
- This course contributes to the assessment of the following program (student) outcomes: an ability to apply knowledge of mathematics, science and engineering an ability to identify, formulate, and solve engineering problems

TEXT BOOKS:

1. Kinematics of Machinery – Special Edition. MRCET, McGrahill Publishers.
2. Theory of Machines by Thomas Bevan/ CBS
3. Theory of machines/ PL. Balaney/khanna publishers.

REFERENCES:

1. The theory of Machines /Shiegley/ Oxford.
2. Mechanism and Machine Theory / JS Rao and RV Dukkipati / New Age International Publishers
3. Theory of Machines / R.K Bansal/Fire Wall media Publisher

COURSE COVERAGE SUMMARY

SUB: - KINEMATICS OF MACHINERY

Units	Chapter No's In The Text Book Covered	Author	Text Book Title	Publishers	Edition
Unit-I Mechanisms & Machines	5 (pg.no.91-118)	R.S.KHURMI & J. K. Gupta	Theory Of Machines	S.CHAND	2005e
Unit-II Straight Line Motion Mechanisms, Steering Mechanisms & Hooke's Joint	9 (pg.no.232-257)	R.S.KHURMI & J. K. Gupta	Theory Of Machines	S.CHAND	2005e
Unit-III Kinematics, Analysis of Mechanisms & Plane motion of body	6,7,8 (pg.no.119-231)	R.S.KHURMI & J. K. Gupta	Theory Of Machines	S.CHAND	2005e
Unit-IV Cams & Analysis of motion of followers	20 (pg.no.774-832)	R.S.KHURMI & J. K. Gupta	Theory Of Machines	S.CHAND	2005e
Unit-V Gears & Gear Trains	12,13 (pg.no.382-478)	R.S.KHURMI & J. K. Gupta	Theory Of Machines	S.CHAND	2005e

CONTENTS

UNIT NO	NAME OF THE UNIT	PAGE NO
I	Machines and Mechanisms	
II	Special Mechanisms	
III	Velocity and Acceleration Analysis	
IV	Cams and Follower	
V	GEARS and Gear Trains	

1

Machines and Mechanisms

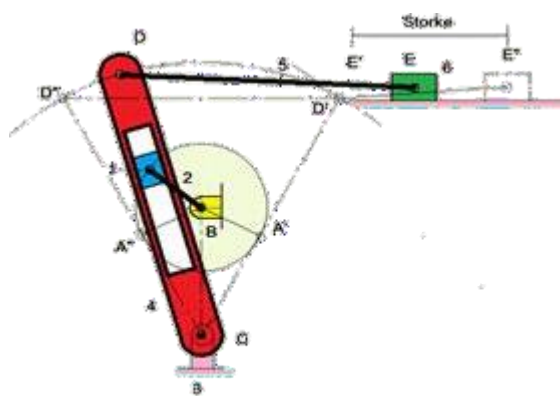
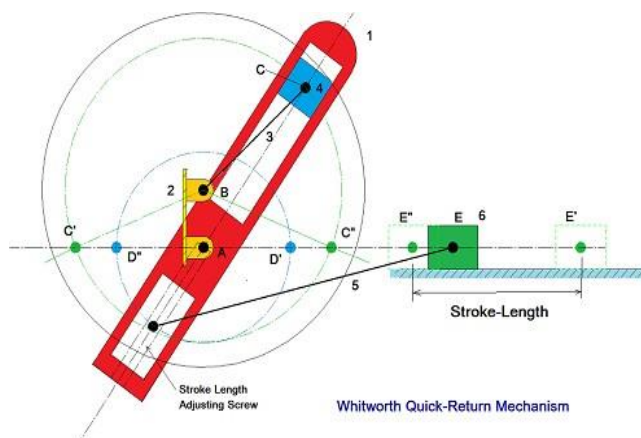

Course Contents

- 1.1 Machine and Mechanism
- 1.2 Types of constrained motion
- 1.3 Types of Link
- 1.4 Kinematic Pairs
- 1.5 Types of Joints
- 1.6 Degrees of Freedom
- 1.7 Kinematic Chain
- 1.8 Kutzbach Criterion
- 1.9 Grubler's criterion
- 1.10 The Four-Bar chain
- 1.11 Grashof's law
- 1.12 Inversion of Mechanism:
- 1.13 Inversion of Four-Bar chain
- 1.14 The slider-crank chain
- 1.15 Whitworth Quick-Return Mechanism:
- 1.16 Rotary engine
- 1.17 Oscillating cylinder engine
- 1.18 Crank and slotted-lever Mechanism
- 1.19 Examples based of D.O.F.

1.1 Machine and Mechanism:

➤ Mechanism:

- If a number of bodies are assembled in such a way that the motion of one causes constrained and predictable motion to the others, it is known as a *mechanism*.

➤ Machine:

- A *machine* is a mechanism or a combination of mechanisms which, apart from imparting definite motions to the parts, also transmits and modifies the available mechanical energy into some kind of desired work.

➤ Analysis:

- *Analysis* is the study of motions and forces concerning different parts of an existing mechanism.

➤ Synthesis:

- *Synthesis* involves the design of its different parts.

1.2 Types of constrained motion:

1.2.1 Completely constrained motion:

- When the motion between a pair is limited to a definite direction irrespective of the direction of force applied, then the motion is said to be a completely constrained motion.
- For example, the piston and cylinder (in a steam engine) form a pair and the motion of the piston is limited to a definite direction (*i.e.* it will only reciprocate) relative to the cylinder irrespective of the direction of motion of the crank.

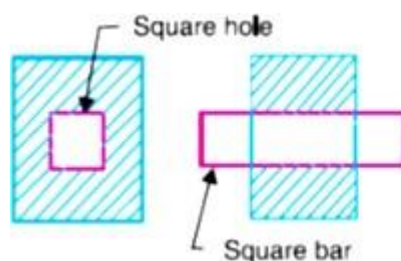

Fig. 1.1

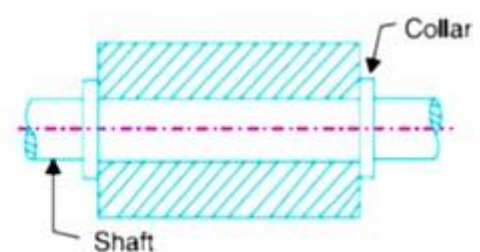

fig. 1.2

- The motion of a square bar in a square hole, as shown in Fig. 1.1, and the motion of a shaft with collars at each end in a circular hole, as shown in Fig. 1.2, are also examples of completely constrained motion.

1.2.2 Incompletely constrained motion:

- When the motion between a pair can take place in more than one direction, then the motion is called an incompletely constrained motion. The change in the direction of impressed force may alter the direction of relative motion between the pair. A circular bar or shaft in a circular hole, as shown in Fig. 1.3, is an

example of an incompletely constrained motion as it may either rotate or slide in a hole. These both motions have no relationship with the other.

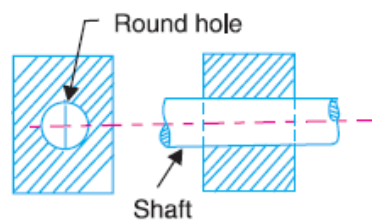

Fig. 1.3

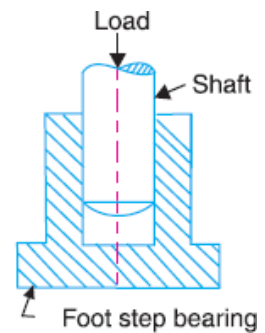

FIG. 1.4

1.2.3 Successfully constrained motion:

- When the motion between the elements, forming a pair, is such that the constrained motion is not completed by itself, but by some other means, then the motion is said to be successfully constrained motion. Consider a shaft in a foot-step bearing as shown in Fig. 1.4.
- The shaft may rotate in a bearing or it may move upwards. This is a case of incompletely constrained motion. But if the load is placed on the shaft to prevent axial upward movement of the shaft, then the motion of the pair is said to be successfully constrained motion. The motion of an I.C. engine

1.3 Types of Links:

- A mechanism is made of a number of resistant bodies out of which some may have motions relative to the others. A resistant body or a group of resistant bodies with rigid connections preventing their relative movements is known as a link.
- A link may also define as a member or a combination of members of a mechanism, connecting other members and having motion relative to them.
- Links may be classified into binary, ternary and quaternary.



Binary link

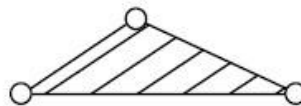

Ternary link

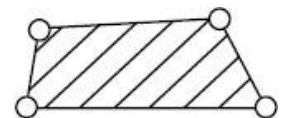

Quaternary link

FIG. 1.4 Types of link

1.4 Kinematic Pair:

- When two kinematic links are connected in such a way that their motion is either completely or successfully constrained, these two links are said to form a kinematic pair.
- Kinematic pairs can be classified according to:

1.4.1 Kinematic pairs according to nature of contact:**a. Lower Pair:**

- A pair of links having surfaced or area contact between the members is known as a lower pair. The contact surfaces of two links are similar.
- Examples: Nut turning on a screw, shaft rotating in a bearing.

b. Higher Pair:

- When a pair has a point or line contact between the links, it is known as a higher pair. The contact surfaces of two links are similar.
- Example: Wheel rolling on a surface, Cam and Follower pair etc.

1.4.2 Kinematic pairs according to nature of contact:**a. Closed Pair:**

- When the elements of a pair are held together mechanically, it is known as a closed pair. The two elements are geometrically identical; one is solid and full and the other is hollow or open. The latter not only envelops the former but also encloses it. The contact between the two can be broken only by destruction of at least one of the members.

b. Unclosed Pair:

- When two links of a pair are in contact either due to force of gravity or some spring action, they constitute an unclosed pair. In this, the links are not held together mechanically, e.g. cam and follower pair.

1.4.3 Kinematic pairs according to Nature of Relative Motion:**a. Sliding pair:**

- When two links have a sliding motion relative to another; the kinematic pair is known as sliding pair.

b. Turning pair:

- When one link is revolve or turn with respect to the axis of first link, the kinematic pair formed by two links is known as turning pair.

c. Rolling pair:

- When the links of a pair have a rolling motion relative to each other, they form a rolling pair.

d. Screw pair:

- If two mating links have a turning as well as sliding motion between them, they form a screw pair.

e. Spherical pair:

- When one link in the form of sphere turns inside a fixed link, it is a spherical pair.

1.5 Types of Joint:

- The usual types of joints in a chain are:
 - Binary Joint
 - Ternary Joint
 - Quaternary Joint
-

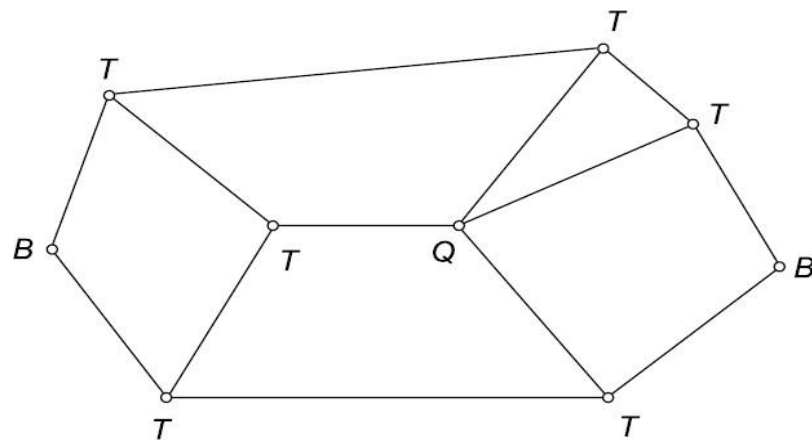

Fig1.5. Types of joint

a. Binary Joint:

- If two links are joined at the same connection, it is called a binary joint. For example, in fig. at joint B

b. Ternary Joint:

- If three links joined at a connection, it is known as a ternary link. For example point T in fig.

c. Quaternary Joint:

- If four links joined at a connection, it is known as a quaternary link. For example point Q in fig.

1.6 Degrees of Freedom:

- An unconstrained rigid body moving in space can describe the following independent motion:
 - Translational motion along any three mutually perpendicular axes x , y and z .
 - Rotational motion about these axes

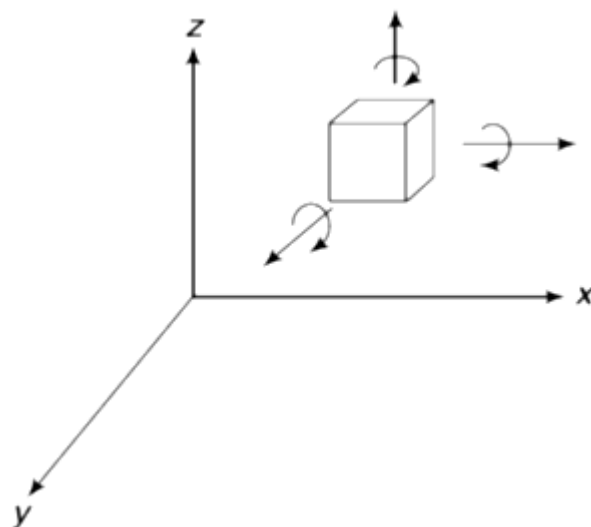

Fig.1.6 Degrees of freedom

- A rigid body possesses six degrees of freedom.

- Degrees of freedom of a pair is defined as the number of independent relative motions, both translational and rotational, a pair can have.
- $DOF = 6 - \text{Number of Restraints}$

1.7 Kinematic chain

- Kinematic chain is defined as the combination of kinematic pairs in which each link forms a part of two kinematic pairs and the relative motion between the links is either completely constrained or successfully constrained.
- Examples: slider-crank mechanism
- For a kinematic chain

$$N = 2P - 4 = 2(j + 2) / 3$$

- Where N = no. of links, P = no. of Pairs and j = no. of joints
- When,

LHS > RHS, then the chain is locked

LHS = RHS, then the chain is constrained

LHS < RHS, then the chain is unconstrained

1.8 Kutzbach Criterion

- DOF of a mechanism in space can be determined as follows:
- In mechanism one link should be fixed. Therefore total no. of movable links are in mechanism is $(N-1)$
- Any pair having 1 DOF will impose 5 restraints on the mechanism, which reduces its total degree of freedom by $5P_1$.
- Any pair having 2 DOF will impose 4 restraints on the mechanism, which reduces its total degree of freedom by $4P_2$
- Similarly, the other pairs having 3, 4 and 5 degrees of freedom reduce the degrees of freedom of mechanism. Thus,
- Thus,

$$F = 6(N-1) - 5P_1 - 4P_2 - 3P_3 - 2P_4 - 1P_5 - 0P_6$$

- Hence,

$$F = 6(N-1) - 5P_1 - 4P_2 - 3P_3 - 2P_4 - 1P_5$$

- The above equation is the general form of **Kutzbach criterion**. This is applicable to any type of mechanism including a spatial mechanism.

1.9 Grubler's criterion

- If we apply the Kutzbach criterion to planer mechanism, then equation of Kutzbach criterion will be modified and that modified equation is known as Grubler's Criterion for planer mechanism.
- Therefore in planer mechanism if we consider the links having 1 to 3 DOF, the total number of degree of freedom of the mechanism considering all restraints will become,

$$F = 3(N-1) - 2P_1 - 1P_2$$

- The above equation is known as **Grubler's criterion** for planer mechanism.
- Sometimes all the above empirical relations can give incorrect results, e.g. fig (a) has 5 links, 6 turning pairs and 2 loops. Thus, it is a structure with zero degree of freedom.

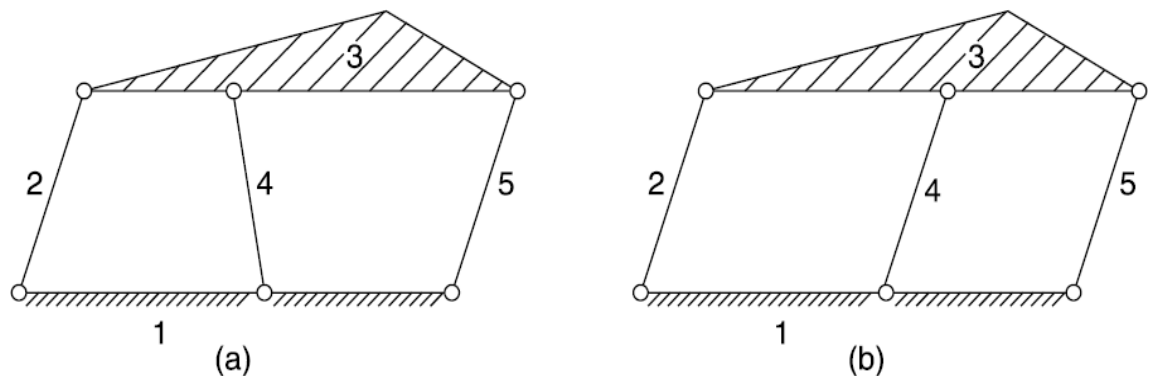

Fig. 1.7

- However, if the links are arranged in such a way as shown in fig. (b), a double parallelogram linkage with one degree of freedom is obtained. This is due to the reason that the lengths of links or other dimensional properties are not considered in these empirical relations.
- Sometimes a system may have one or more link which does not introduce any extra constraint. Such links are known as redundant links and should not be counted to find the degree of freedom. For example fig. (B) has 5 links, but the function of the mechanism is not affected even if any one of the links 2, 4 and 5 are removed. Thus, the effective number of links in this case is 4 with 4 turning pairs, and thus 1 degree of freedom.
- In case of a mechanism possessing some redundant degree of freedom, the effective degree of freedom is given by,

$$F = 3(N - 1) - 2P_1 - 1P_2 - F_r$$

- Where F_r = no. of redundant degrees of freedom

1.10 The Four-Bar chain

- A four bar chain is the most fundamental of the plane kinematic chains. It is a much proffered mechanical device for the mechanisation and control of motion due to its simplicity and versatility. Basically, it consists of four rigid links which are connected in the form of a quadrilateral by four pin-joints.
- When one of the link fixed, it is known as mechanism or linkage. A link that makes complete revolution is called the crank. The link opposite to the fixed link is called coupler, and the forth link is called a lever or rocker if it oscillates or another crank if it rotates.
- It is impossible to have a four-bar linkage if the length of one of the link is greater than the sum of other three. This has been shown in fig.

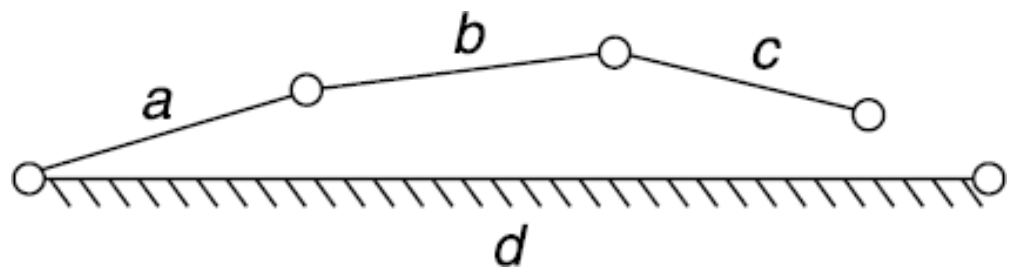

Fig. 1.7 Four bar chain

1.11 Grashof's law:

- We have already discussed that the kinematic chain is a combination of four or more kinematic pairs, such that the relative motion between the links or elements is completely constrained. The simplest and the basic kinematic chain is a four bar chain or quadric cycle chain, as shown in Fig. 5.18. It consists of four links, each of them forms a turning pair at A, B, C and D. The four links may be of different lengths.
- According to Grashof's law for a four bar mechanism, the sum of the shortest and longest link lengths should not be greater than the sum of the remaining two link lengths if there is to be continuous relative motion between the two links.

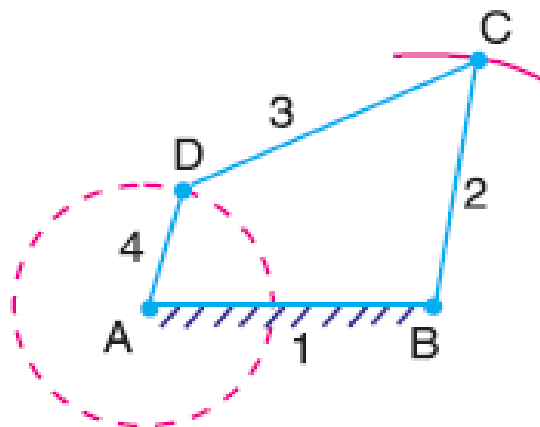

Fig. 1.8 Grashof's law

- A very important consideration in designing a mechanism is to ensure that the input crank makes a complete revolution relative to the other links. The mechanism in which no link makes a complete revolution will not be useful. In a four bar chain, one of the links, in particular the shortest link, will make a complete revolution relative to the other three links, if it satisfies the Grashof's law. Such a link is known as crank or driver. In Fig. 5.18, AD (link 4) is a crank.
- The link BC (link 2) which makes a partial rotation or oscillates is known as lever or rocker or follower and the link CD (link 3) which connects the crank and lever is called connecting rod or coupler. The fixed link AB (link 1) is known as frame of the mechanism.

1.12 Inversion of Mechanism:

- When the number of links in kinematic chain is more than three, the chain is known as mechanism. When one link of the kinematic chain at a time is fixed, give the different mechanism of the kinematic chain. The method of generating different mechanism by fixing a link is called the inversion of mechanism.
- The number of inversion is equal to the numbers of links in the kinematic chain.
- The inversion of mechanism may be classified as:
 - a. Inversion of four-bar chain
 - b. Inversion of single slider crank chain
 - c. Inversion of double slider crank chain

1.13 Inversion of Four-Bar chain

1.13.1 First inversion: coupled wheel of locomotive

- The mechanism of a coupling rod of a locomotive (also known as double crank mechanism) which consists of four links is shown in Fig.

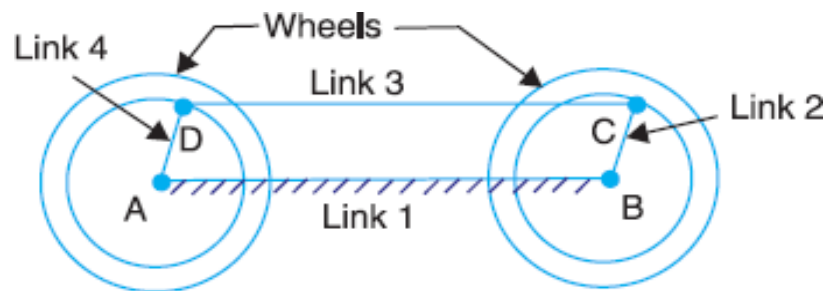

Fig. 1.9 coupled wheel of locomotive

- In this mechanism, the links AD and BC (having equal length) act as cranks and are connected to the respective wheels. The link CD acts as a coupling rod and the link AB is fixed in order to maintain a constant centre to Centre distance between them. This mechanism is meant for transmitting rotary motion from one wheel to the other wheel.

1.13.2 Second inversion: Beam Engine

- A part of the mechanism of a beam engine (also known as cranks and lever mechanism) which consists of four links is shown in Fig. 1.10.
- In this mechanism, when the crank rotates about the fixed centre A , the lever oscillates about a fixed centre D . The end E of the lever CDE is connected to a piston rod which reciprocates due to the rotation of the crank.

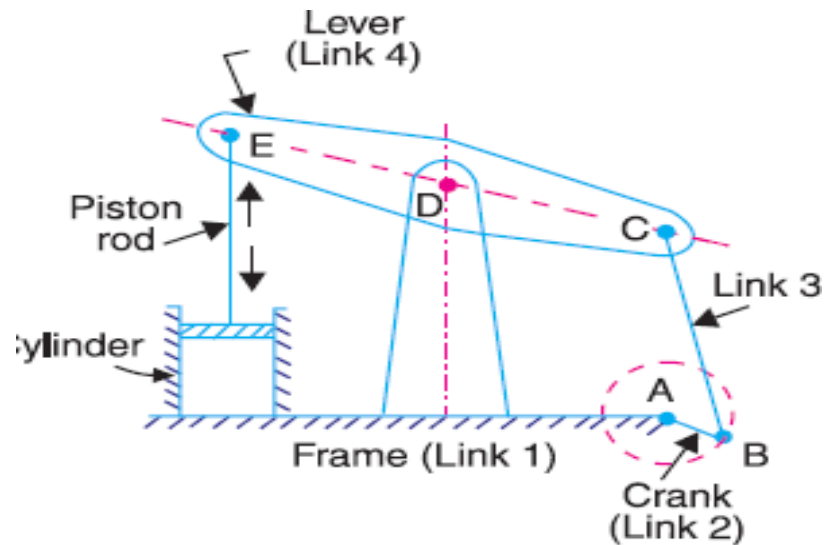

Fig. 1.10 beam engine

- In other words, the purpose of this mechanism is to convert rotary motion into reciprocating motion.

1.13.3 Third inversion: wats indicator mechanism

- A Watt's indicator mechanism (also known as Watt's straight line mechanism or double lever mechanism) which consists of four links is shown in Fig.
- The four links are: fixed link at A, link AC, link CE and link BFD. It may be noted that BF and FD form one link because these two parts have no relative motion between them. The links CE and BFD act as levers.
- The displacement of the link BFD is directly proportional to the pressure of gas or steam which acts on the indicator plunger. On any small displacement of the mechanism, the tracing point E at the end of the link CE traces out approximately a straight line.

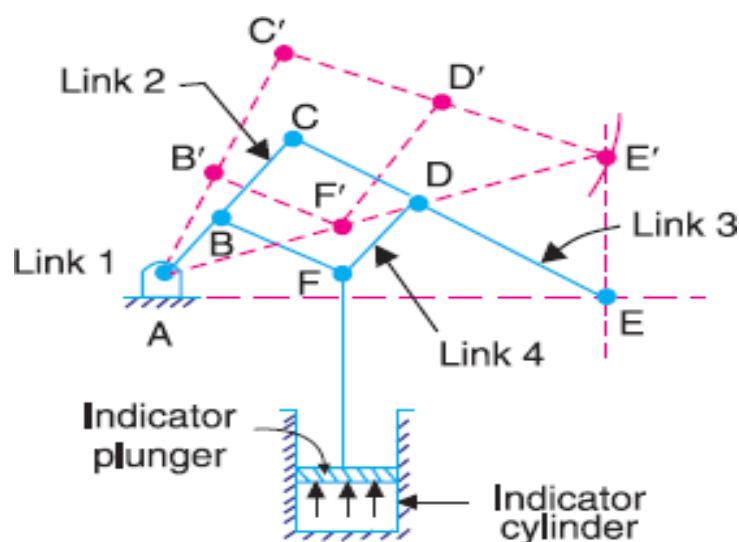

Fig. 1.11 wats indicator mechanism

1.14 The slider-crank chain

- When one of the turning pairs of a four-bar chain is replaced by a sliding pair, it becomes a single slider-crank chain or simply a slider-crank chain.
- It is also possible to replace two sliding pairs of a four-bar chain to get a double slider-crank chain. In a slider-crank chain, the straight line path of the slider may be passing through the fixed pivot O or may be displaced.
- The distance e between the fixed pivot O and the straight line path of the slider is called the offset and the chain so formed an offset slider-crank chain.
- Different mechanisms obtained by fixing different links of a kinematic chain are known as its inversions.

1.14.1 First inversion

- This inversion is obtained when link 1 is fixed and links 2 and 4 are made the crank and slider respectively. (fig.a)
- **Applications:**
 - Reciprocating engine
 - Reciprocating compressor

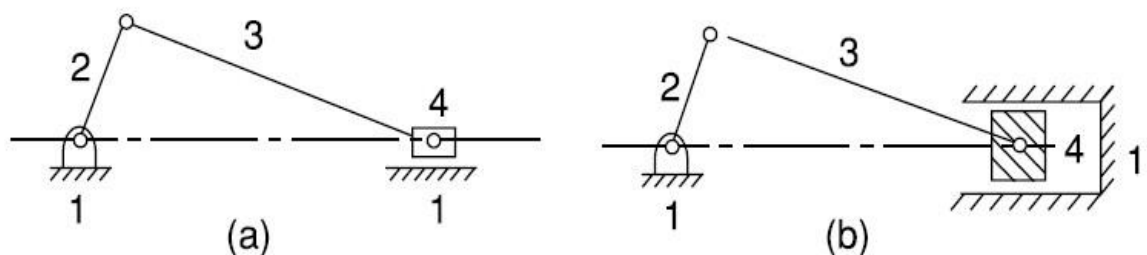

Fig. 1.12 First inversion

1.14.2 Second inversion

- Fixing of the link 2 of a slider-crank chain results in the second inversion.
- **Applications:**
 - Whitworth quick-return mechanism
 - Rotary engine

1.14.3 Third Inversion

- By Fixing of the link 3 of the slider-crank mechanism, the third inversion is obtained. Now the link 2 again acts as a crank and the link 4 oscillates.
- **Applications:**
 - Oscillating cylinder engine
 - Crank and slotted-lever mechanism

1.14.4 Fourth Inversion

- If the link 4 of the slider-crank mechanism is fixed, the fourth inversion is obtained. Link 3 can oscillates about the fixed pivot B on the link 4. This makes

the end A of the link 2 to oscillate about B and the end O to reciprocate along the axis of the fixed link 4.

– **Application: Hand Pump**

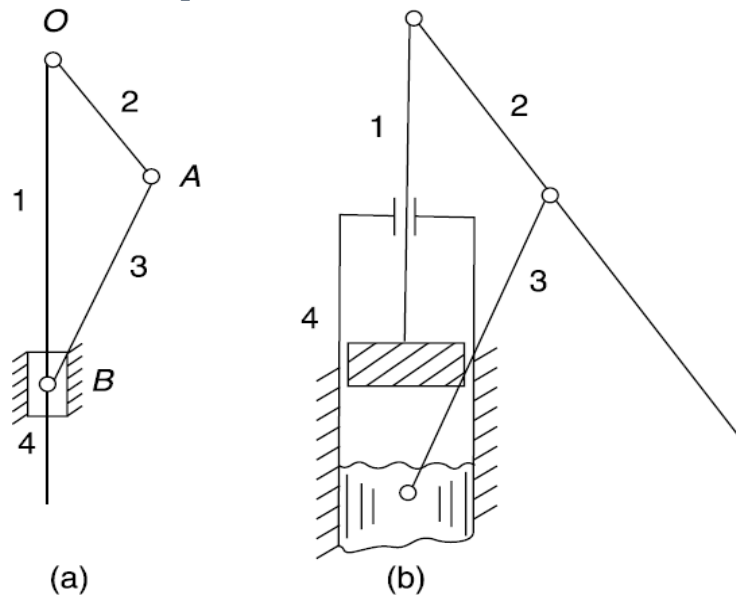

Fig. 1.13 hand pump

- Fig.1.13 shows a hand-pump. Link 4 is made in the form of a cylinder and a plunger fixed to the link 1 reciprocates in it.

1.15 Whitworth Quick-Return Mechanism:

- This mechanism used in shaping and slotting machines.
- In this mechanism the link CD (link 2) forming the turning pair is fixed; the driving crank CA (link 3) rotates at a uniform angular speed and the slider (link 4) attached to the crank pin at a slides along the slotted bar PA (link 1) which oscillates at D.
- The connecting rod PR carries the ram at R to which a cutting tool is fixed and the motion of the tool is constrained along the line RD produced.

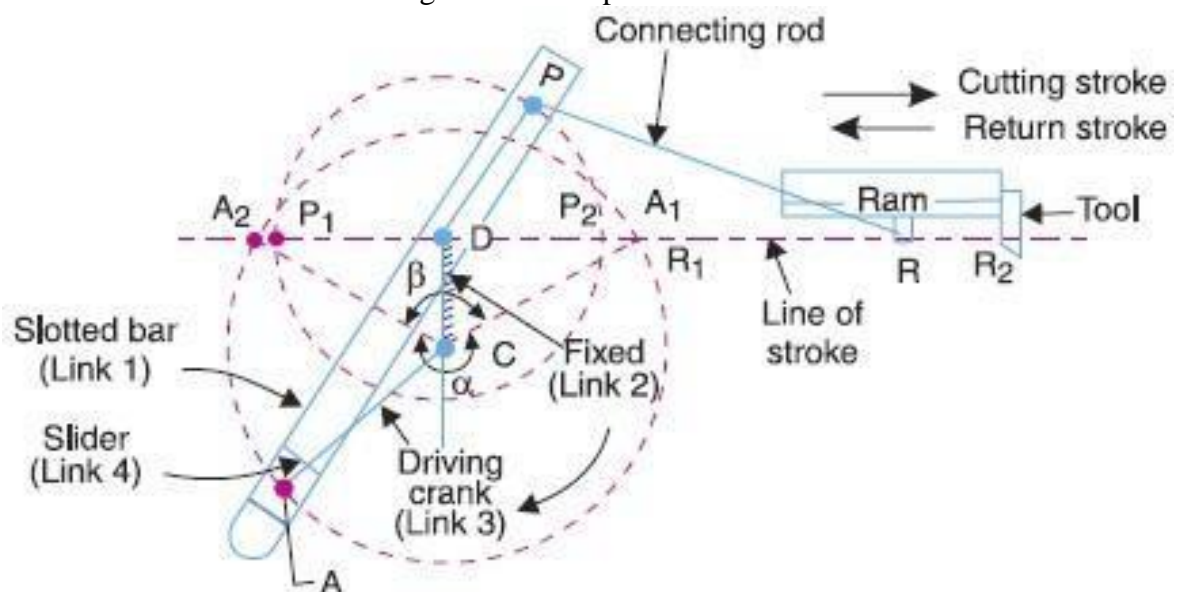

Fig. 1.14 Whitworth quick returns mechanism

- In this mechanism, the link 3 forming the turning pair is fixed. The link 3 corresponds to the connecting rod of a reciprocating steam engine mechanism. When the crank (link 2) rotates, the piston attached to piston rod (link 1) reciprocates and the cylinder (link 4) oscillates about a pin pivoted to the fixed link at A.

1.18 Crank and slotted-lever Mechanism

- This mechanism is mostly used in shaping machines, slotting machines and in rotary internal combustion engines.
- In this mechanism, the link AC (i.e. link 3) forming the turning pair is fixed, as shown in Fig. The link 3 corresponds to the connecting rod of a reciprocating steam engine. The driving crank CB revolves with uniform angular speed about the fixed center C. A sliding block attached to the crank pin at B slides along the slotted bar AP and thus causes AP to oscillate about the pivoted point A.
- A short link PR transmits the motion from AP to the ram which carries the tool and reciprocates along the line of stroke R1R2. The line of stroke of the ram (i.e. R1R2) is perpendicular to AC produced.

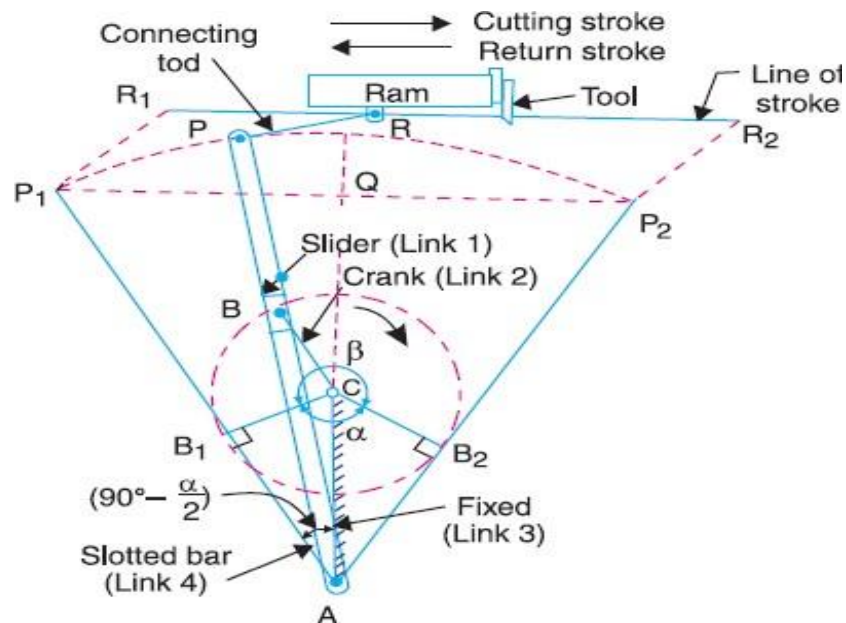

Fig.1.17 Crank and slotted lever mechanism

- In the extreme positions, AP1 and AP2 are tangential to the circle and the cutting tool is at the end of the stroke. The forward or cutting stroke occurs when the crank rotates from the position CB1 to CB2 (or through an angle β) in the clockwise direction. The return stroke occurs when the crank rotates from the position CB2 to CB1 (or through angle α) in the clockwise direction. Since the crank has uniform angular speed, therefore,

$$\frac{\text{time of return}}{\alpha} = \frac{\beta}{360^\circ - \beta} = \frac{360^\circ - \alpha}{\alpha}$$

1.19 Example based on Degrees of Freedom:

1 For the kinematic linkages shown in following fig. calculate the following:

The numbers of binary links (N_b)

The numbers of ternary links (N_t)

The numbers of other (quaternary) links (N_o)

The numbers of total links (n)

The numbers of loops (L)

The numbers of joints or pairs (P_1)

The numbers of degrees of freedom

(F)

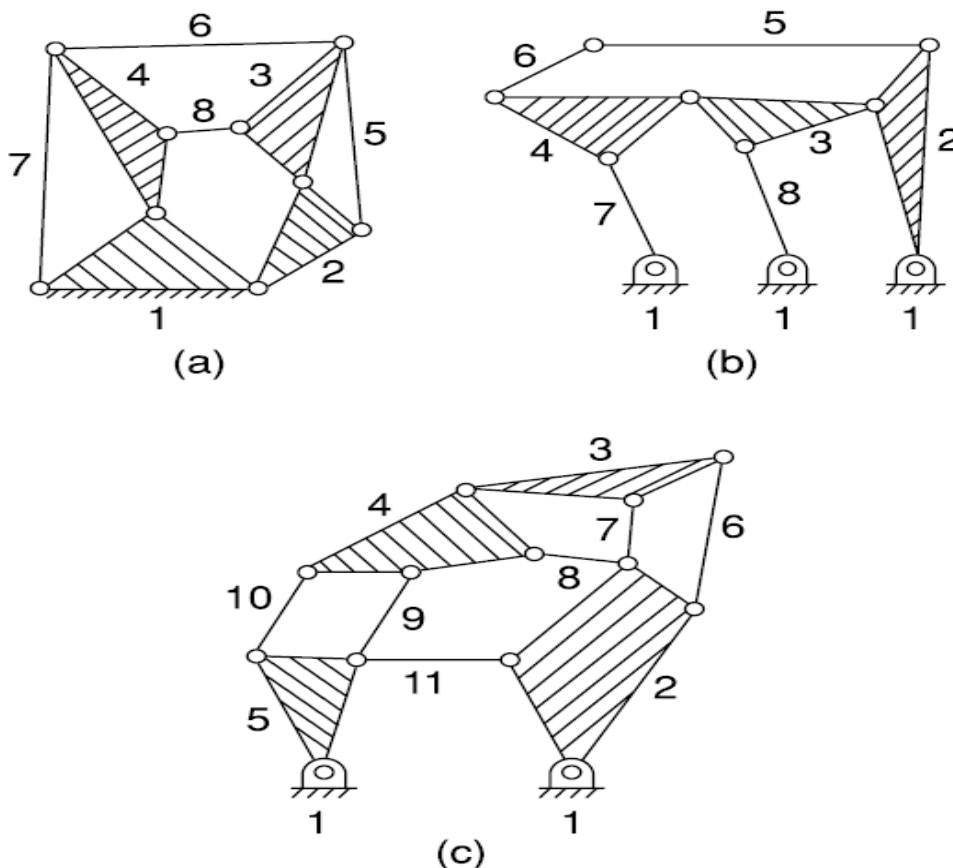

a $N_b = 4$; $N_t = 4$; $N_o = 0$; $N = 8$; $L = 4$; $P_1 = 11$ (by counting) $P_1 = (N + L - 1) = 11$

$$F = 3(N - 1) - 2P_1$$

$$F = 3(8 - 1) - 2 \times 11 = -1 \text{ or,}$$

$$v F = N - (2L + 1)$$

$$F = 8 - (2 \times 4 + 1) = -1$$

b $N_b = 4$; $N_t = 4$; $N_o = 0$; $N = 8$; $L = 3$; $P_1 = 10$ (by counting) $P_1 = (N + L - 1) = 10$

$$F = 3(N - 1) - 2P_1$$

$$F = 3(8 - 1) - 2 \times 10 = 1$$

$$\text{or, } F = N - (2L + 1)$$

$$F = 8 - (2 \times 3 + 1) = 1$$

c $N_b = 7$; $N_t = 2$; $N_0 = 2$; $N = 11$; $L = 5$; $P_1 = 15$ (by counting) $F = N - (2L + 1)$

$$F = 11 - (2 \times 5 + 1) = 0$$

Therefore the linkage is a structure.

References

1. Theory of Machines by S.S.Rattan, Tata McGraw Hill
 2. Theory of Machines by R.S. Khurmi & J.K.Gupta,S.Chan d
 3. Theory of machines and mechanisms by P.L.Ballaney by Khanna Publication
-

2

Special Mechanisms

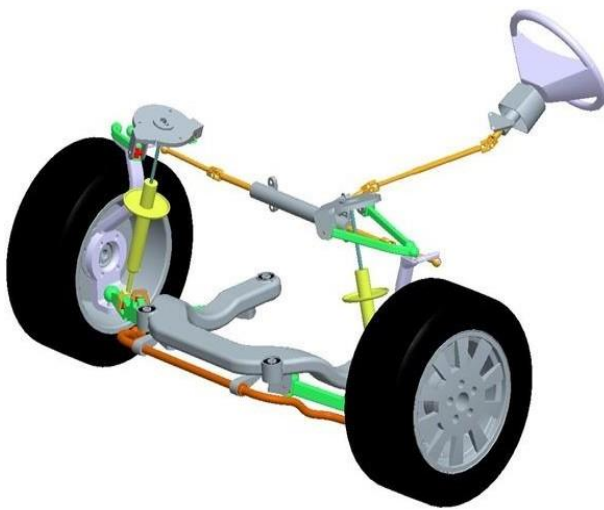

Course Contents

- 2.1 Straight line mechanisms
- 2.2 Exact straight line mechanisms made up of turning pair
- 2.3 Peaucellier mechanism
- 2.4 Hart's Mechanism
- 2.5 Exact straight line motion consisting of one sliding pair
- 2.6 Approximate straight line motion mechanisms
- 2.7 Steering gear mechanism
- 2.8 Devis steering gear
- 2.9 Ackerman steering gear
- 2.10 Universal or Hooke's joint
- 2.11 Ratio of shaft velocities
- 2.12 Max. and Min. speed of driven shaft
- 2.13 Polar diagram
- 2.14 Double Hooke's Joint
- 2.15 Examples

2.1 Straight Line Mechanisms

- It permits only relative motion of an oscillatory nature along a straight line. The mechanisms used for this purpose are called *straight line mechanisms*.
 - 1 In which only turning pairs are used
 - 2 In which one sliding pair is used.
- These two types of mechanisms may produce exact straight line motion or approximate straight line motion.
- **Need of Straight Line:**
 - 1 Sewing Machine converts rotary motion to up/down motion.
 - 2 Want to constrain pistons to move only in a straight line.
 - 3 How do you create the first straight edge in the world? (Compass is easy)
 - 4 Windshield wipers, some flexible lamps made of solid pieces connected by flexible joints.

2.2 Exact Straight Line Motion Mechanisms Made Up Of Turning Pairs

- The principle adopted for a mathematically correct or exact straight line motion is described in Fig.4.1
- Let O be a point on the circumference of a circle of diameter OP. Let OA be any chord and B is a point on OA produced, such that

$$OA \times OB = \text{constant}$$
- The triangles OAP and OBQ are similar.

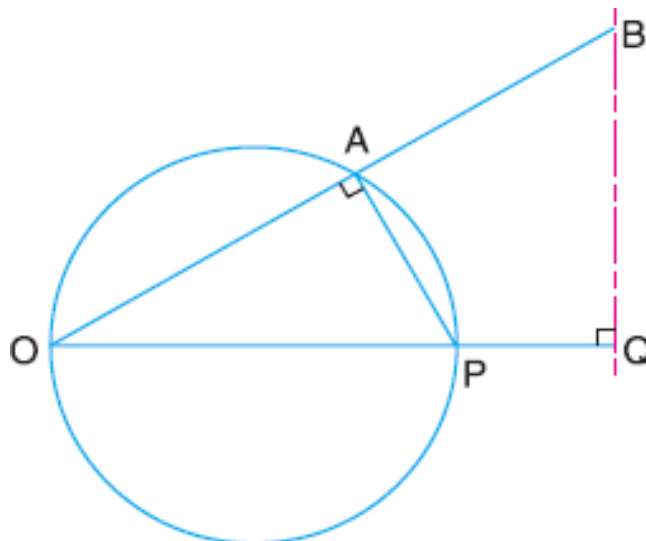

Fig. 4.1 Exact straight line motion mechanism

$$\frac{OA}{OP} = \frac{OQ}{OB}$$

$$OP \times OQ = OA \times OB$$

$$OQ = \frac{OA \times OB}{OP}$$

- But OP is constant as it is the diameter of a circle; therefore, if $OA \times OB$ is constant, then OQ will be constant.
- Hence

$$OA \times OB = \text{constant}$$

- So point B moves along the straight line.

2.3 Peaucellier Mechanism (Exact Straight Line)

- It consists of a fixed link OO_1 and the other straight links O_1A , OC , OD , AD , DB , BC and CA are connected by turning pairs at their intersections, as shown in Fig. 4.2
- The pin at A is constrained to move along the circumference of a circle with the fixed diameter OP , by means of the link O_1A . In Fig. 4.2
- $AC = CB = BD = DA$
- $OC = OD$
- $OO_1 = O_1A$

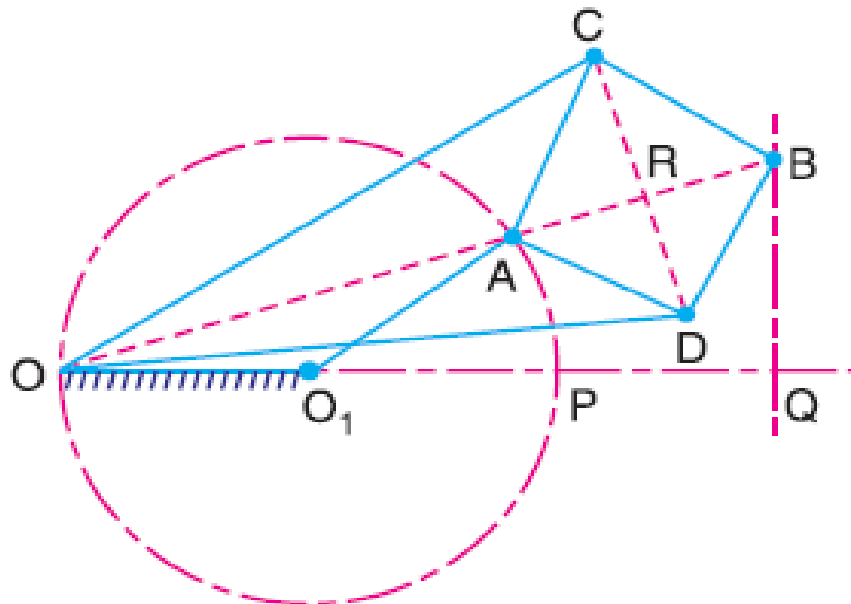

Fig. 4.2 Peaucellier Mechanism

- From right angled triangles ORC and BRC , we have

$$OC^2 = OR^2 + RC^2 \quad (I)$$

$$BC^2 = RB^2 + RC^2 \quad (ii)$$

- From (i) and (ii)

$$\begin{aligned} OC^2 - BC^2 &= OR^2 - RB^2 \\ &= (OR - RB)(OR + RB) \end{aligned}$$

$$= OB \times OA$$

- Since OC and BC are of constant length, therefore the product $OB \times OA$ remains constant.

Hart's Mechanism

- This mechanism requires only six links as compared with the eight links required by the Peaucellier mechanism.
- It consists of a fixed link OO_1 and other straight links O_1A , FC , CD , DE and EF are connected by turning pairs at their points of intersection, as shown in Fig. 4.3.
- The links FC and DE are equal in length and the lengths of the links CD and EF are also equal. The points O , A and B divide the links FC , CD and EF in the same ratio. A little consideration will show that $BOCE$ is a trapezium and OA and OB are respectively parallel to FD and CE .

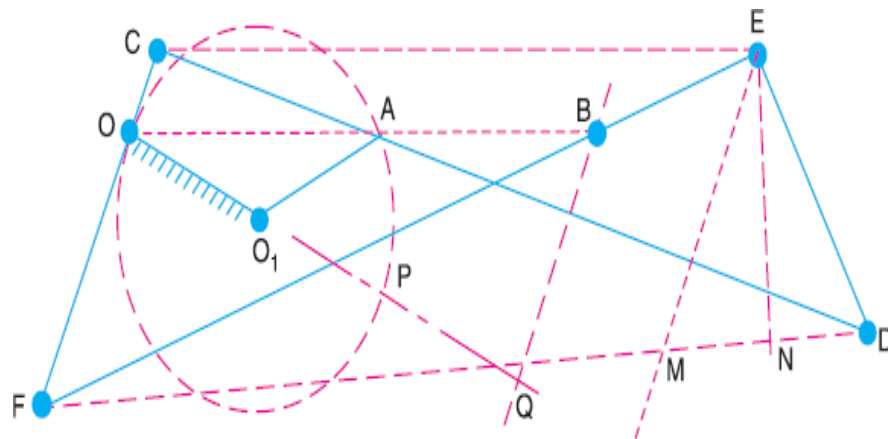

Fig. 4.3 Hart's Mechanism

- Here, $FC = DE$ & $CD = EF$
- The point O , A and B divide the links FC , CD and EF in the same ratio.
- From similar triangles CFE and OFB ,

$$\frac{CE}{FC} = \frac{OB}{OF} \text{ or } CB = \frac{CE \times OF}{FC} \dots \dots (i)$$

- From similar triangle FCD and OCA

$$\frac{FD}{FC} = \frac{OA}{OC} \text{ or } OA = \frac{FD \times OC}{FC} \dots \dots (ii)$$

- From above equations,

$$\begin{aligned} OA \times OB &= \frac{FD \times OC}{FC} \times \frac{CE \times OF}{FC} \\ &= FD \times CE \times \frac{OC \times OF}{FC^2} \end{aligned}$$

- Since the lengths of OC , OF and FC are fixed, therefore

$$OA \times OB = FD \times CE \times \text{cons.} \dots (iii)$$

- From point E , draw EM parallel to CF and EN perpendicular to FD .

$$\begin{aligned}
 FD \times CE &= FD \times FM \quad (CE = FM) \\
 &= (FN + ND)(FN - MN) \\
 &= FN^2 - ND^2 \quad (MN = ND) \\
 &= (FE^2 - NE^2) - (ED^2 - NE^2) \quad (\text{From right}
 \end{aligned}$$

angle triangles FEN and EDN)

$$= E^2 - ED^2 = \text{constant} \quad (iv)$$

- From equation (iii) and (iv),

$$OA \times OB = \text{constant}$$

Exact Straight Line Motion consisting of one sliding pair-Scott

Russell's Mechanism

- A is the middle point of PQ and $OA = AP = AQ$. The instantaneous center for the link PAQ lies at I in OA produced and is such that IP is perpendicular to OP.

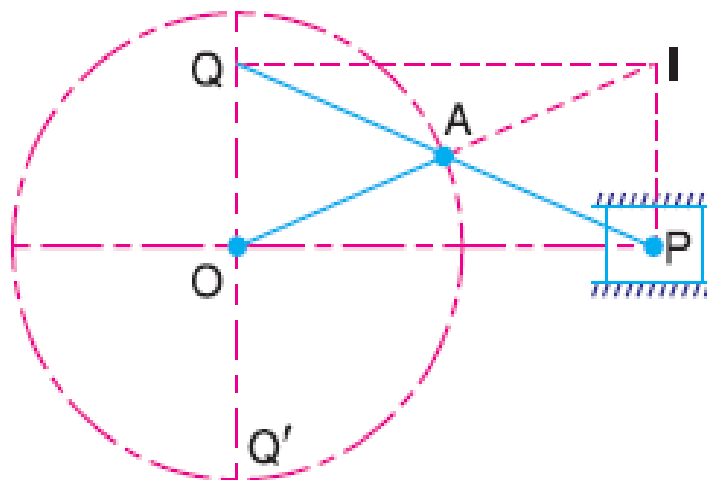

Fig. 4.4 Scott Russell's Mechanism

- Join IQ. Then Q moves along the perpendicular to IQ. Since OPIQ is a rectangle and IQ is perpendicular to OQ, therefore Q moves along the vertical line OQ for all positions of QP. Hence Q traces the straight line OQ'.
- If OA makes one complete revolution, then P will oscillate along the line OP through a distance $2 OA$ on each side of O and Q will oscillate along OQ' through the same distance $2 OA$ above and below O. Thus, the locus of Q is a copy of the locus of P.

Approximate straight line motion mechanisms

Watt's Mechanism

- It has four links as shown in fig. OB, O1A, AB and OO1.

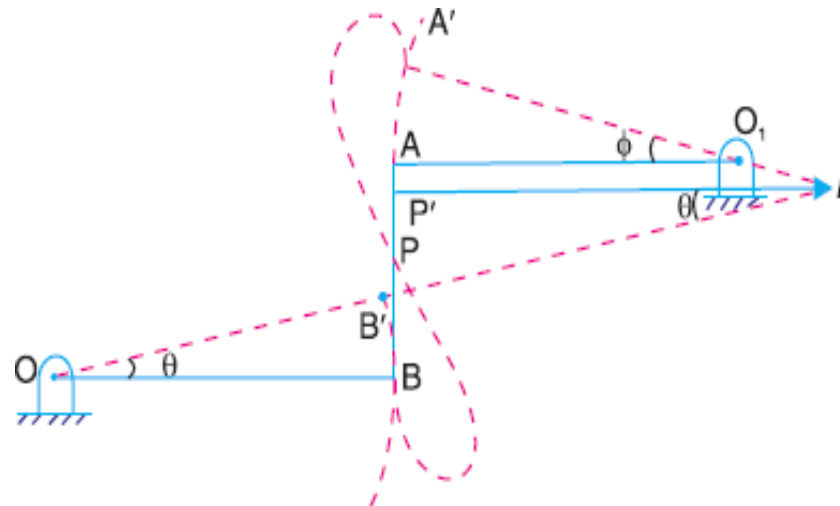

Fig. 4.5 watt's mechanism

- OB and O1A oscillates about centers O and O1 respectively. P is a point on AB such that,

$$\frac{O_1A}{OB} = \frac{PB}{PA}$$

- As OB oscillates the point P will describe an approximate straight line.

Modified Scott-Russel Mechanism

- This is similar to Scott-Russel mechanism but in this case AP is not equal to AQ and the points P and Q are constrained to move in the horizontal and vertical directions.

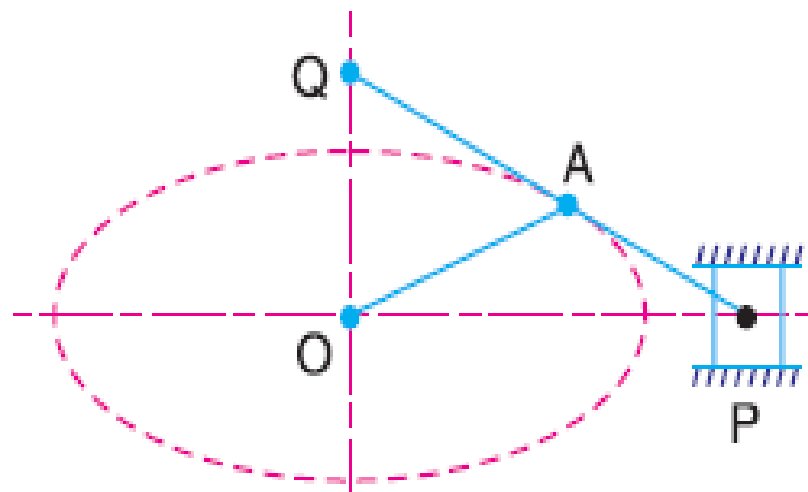

Fig. 4.6 Modified Scott-Russel Mechanisms

- A little consideration will show that it forms an elliptical trammel, so that any point A on PQ traces an ellipse with semi-major axis AQ and semi minor axis AP .
- If the point A moves in a circle, then for point Q to move along an approximate straight line, the length OA must be equal $(AP)^2 / AQ$. This is limited to only small displacement of P .

Grasshopper Mechanism

- In this mechanism, the centers O and O_1 are fixed. The link OA oscillates about O through an angle AOA_1 which causes the pin P to move along a circular arc with O_1 as center and O_1P as radius.

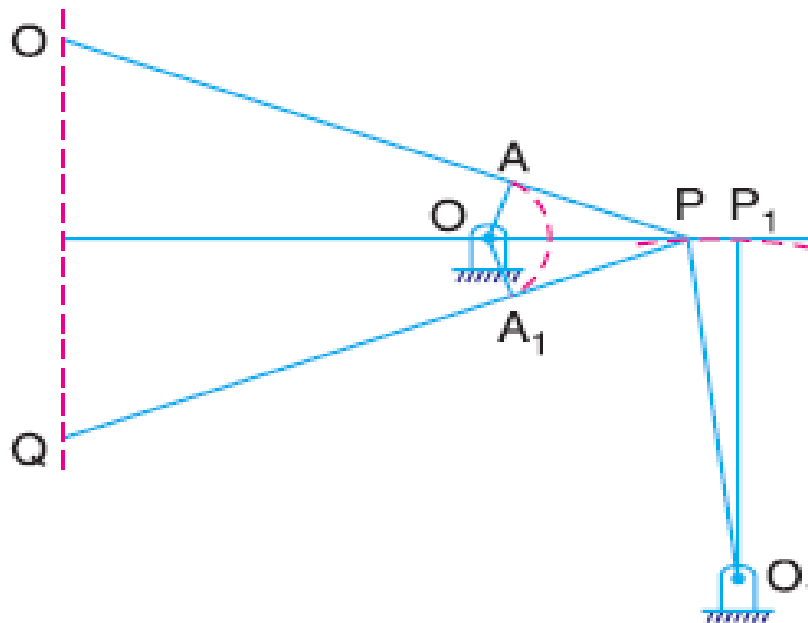

Fig. 4.7 Grasshopper Mechanism

- For small angular displacements of OP on each side of the horizontal, the point Q on the extension of the link PA traces out an approximately a straight path QQ' . if the lengths are such that

$$OA = \frac{AP^2}{AQ}$$

Tchebicheff's Mechanism

- It is a four bar mechanism in which the crossed links OA and O_1B are of equal length, as shown in Fig. 4.8.
- The point P , which is the mid-point of AB , traces out an approximately straight line parallel to OO_1 .

- The proportions of the links are, usually, such that point P is exactly above O or O₁ in the extreme positions of the mechanism i.e. when BA lies along OA or when BA lies along BO₁.

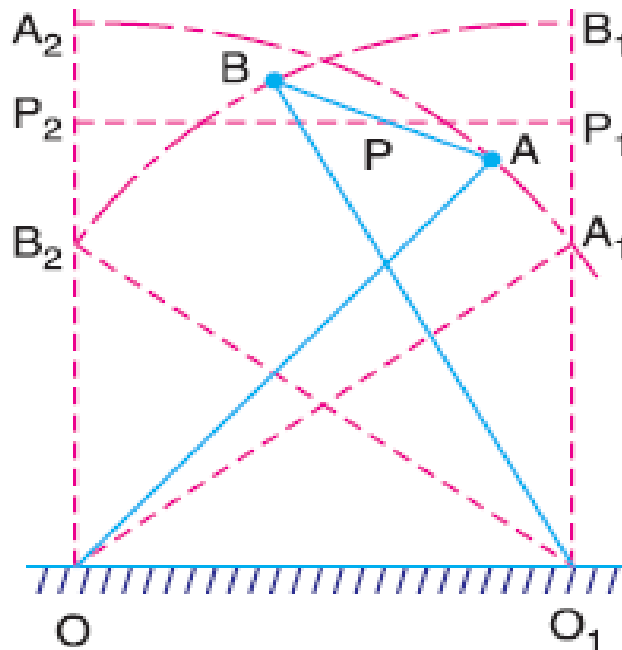

Fig. 4.8 Tchebicheff's mechanism

- It may be noted that the point P will lie on a straight line parallel to OO₁, in the two extreme positions and in the mid position, if the lengths of the links are in proportions

$$AB : OO_1 : OA = 1 : 2 : 4.5.$$

Roberts Mechanism

- It is also a four bar chain mechanism, which, in its mean position, has the form of a trapezium. The links OA and O₁B are of equal length and OO₁ is fixed. A bar PQ is rigidly attached to the link AB at its middle point P.

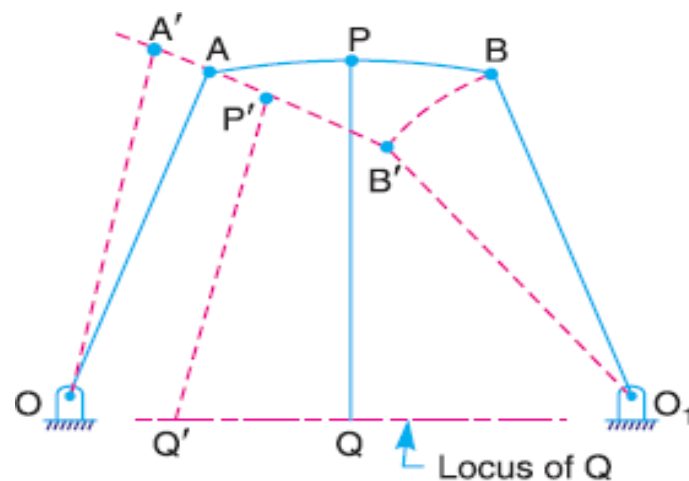

Fig. 4.9 Robert's Mechanism

- A little consideration will show that if the mechanism is displaced as shown by the dotted lines in Fig. the point Q will trace out an approximately straight line.

Steering gear mechanism

- The steering gear mechanism is used for changing the direction of two or more of the wheel axles with reference to the chassis, so as to move the automobile in any desired path.
- Usually the two back wheels have a common axis, which is fixed in direction with reference to the chassis and the steering is done by means of the front wheels.
- In automobiles, the front wheels are placed over the front axles, which are pivoted at the points A and B, as shown in Fig. 4.10.

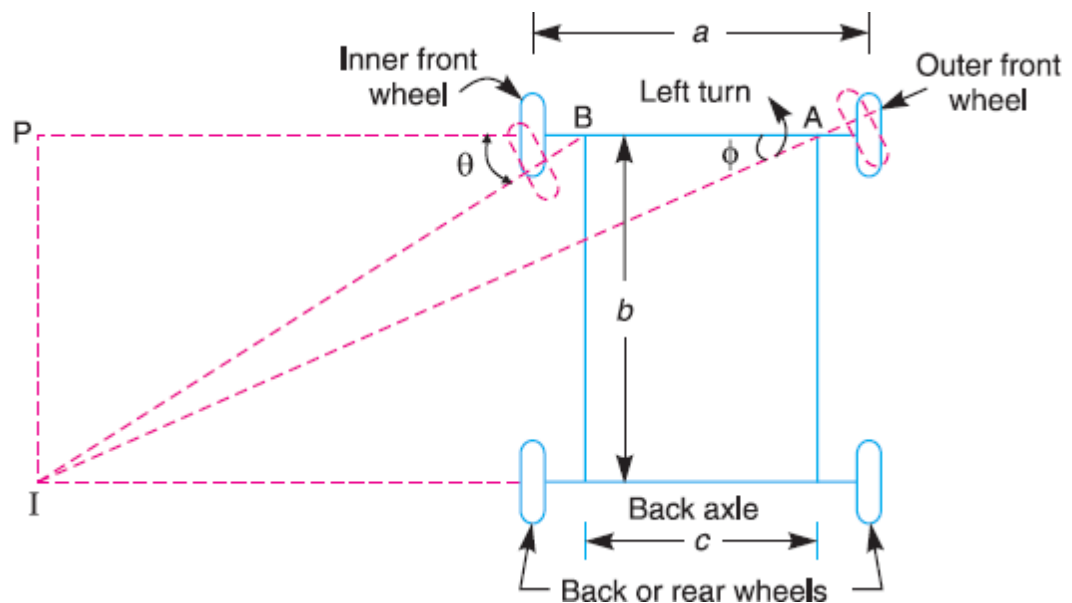

Fig. 4.10 steering gear mechanism

- These points are fixed to the chassis. The back wheels are placed over the back axle, at the two ends of the differential tube. When the vehicle takes a turn, the front wheels along with the respective axles turn about the respective pivoted points. The back wheels remain straight and do not turn. Therefore, the steering is done by means of front wheels only.
- In order to avoid skidding (i.e. slipping of the wheels sideways), the two front wheels must turn about the same instantaneous centre I which lies on the axis of the back wheels. If the instantaneous centre of the two front wheels do not coincide with the instantaneous Centre of the back wheels, the skidding on the front or back wheels will definitely take place, which will cause more wear and tear of the tyres

- Thus, the condition for correct steering is that all the four wheels must turn about the same instantaneous centre. The axis of the inner wheel makes a larger turning angle θ than the angle ϕ subtended by the axis of outer wheel.
- Let, a = wheel track
 b = wheel base
 c = Distance between the pivots A and B of the front axle.
- Now from triangle IBP,

$$\cot\theta = \frac{BP}{IP}$$

- And from triangle IAP,

$$\cot\phi = \frac{AP}{IP} = \frac{AB + BP}{IP} = \frac{c}{b} + \cot\theta$$

$$\cot\phi - \cot\theta = \frac{c}{b}$$

- This is the fundamental equation for correct steering.

Devis Steering Mechanism

- The Davis steering gear is shown in Fig. 9.16. It is an exact steering gear mechanism. The slotted links AM and BH are attached to the front wheel axle, which turn on pivots A and B respectively.
- The rod CD is constrained to move in the direction of its length, by the sliding members at P and Q. These constraints are connected to the slotted link AM and BH by a sliding and a turning pair at each end. The steering is affected by moving CD to the right or left of its normal position. C 'D' shows the position of CD for turning to the left.

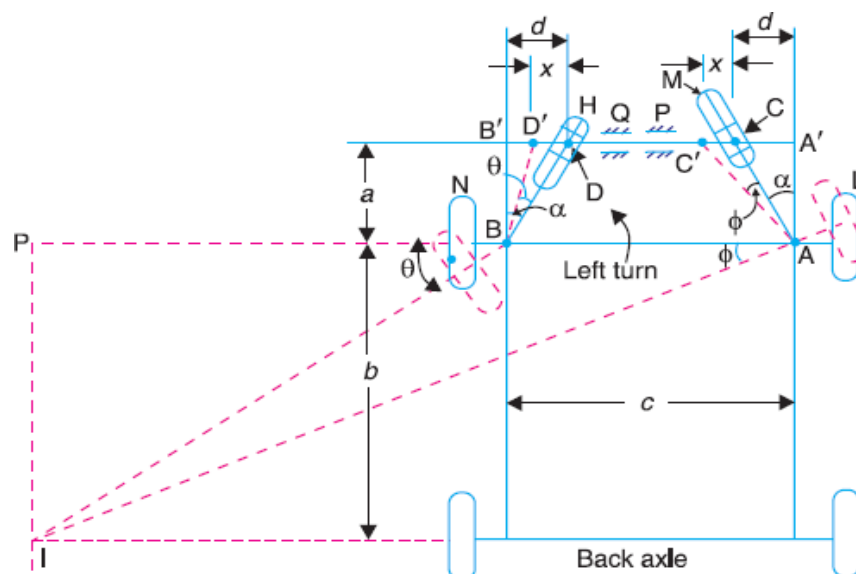

Fig. 4.11 Devis steering gear mechanism

– Let,

- a = Vertical distance between AB and CD,
- b = Wheel base,
- d = Horizontal distance between AC and BD,
- c = Distance between the pivots A and B of the front axle.
- x = Distance moved by AC to AC' = CC' = DD', and
- α = Angle of inclination of the links AC and BD, to the vertical.

– From triangle AA'C'

$$\tan(\alpha + \phi) = \frac{A'C'}{A'A'} = \frac{d + x}{a} \dots \dots \dots (i)$$

– From triangle AA'C

$$\tan \alpha = \frac{A'C}{A'A'} = \frac{d}{a} \dots \dots \dots (ii)$$

– From triangle BB'D'

$$\tan(\alpha - \theta) = \frac{B'D'}{BB'} = \frac{d - x}{a} \dots \dots \dots (iii)$$

– We know that,

$$\begin{aligned} \tan(\alpha + \phi) &= \frac{\tan \alpha + \tan \phi}{1 - \tan \alpha \times \tan \phi} \\ \frac{d + x}{a} &= \frac{d/a + \tan \phi}{1 - d/a \times \tan \phi} = \frac{d + (\times \tan \phi)}{a - (\times \tan \phi)} \\ d \cdot x \times (a - d \times \tan \phi) &= a \times (d + a \times \tan \phi) \\ a \cdot d - d^2 \times \tan \phi + a \cdot x - d \times x \times \tan \phi &= a \cdot d + ^2 \times \tan \phi \\ \tan \phi \times (a^2 + d^2 + d \cdot x) &= a \cdot x \\ \tan \phi &= \frac{a \cdot x}{(a^2 + d^2 + d \cdot x)} \dots \dots \dots (iv) \end{aligned}$$

– Similarly from $\tan(\alpha - \theta) = \frac{d-x}{a}$, we get

$$\tan \theta = \frac{a \cdot x}{(a^2 + d^2 - d \cdot x)} \dots \dots \dots (v)$$

– We know that for correct steering,

$$\begin{aligned} \cot \phi - \cot \theta &= \frac{c}{b} \\ \frac{(a^2 + d^2 + d \cdot x)}{a \cdot x} - \frac{(a^2 + ^2 - d \cdot x)}{a \cdot x} &= \frac{c}{b} \\ \frac{2d}{a} &= \frac{c}{b} \\ 2 \tan \alpha &= \frac{c}{b} \\ \tan \alpha &= \frac{c}{2b} \end{aligned}$$

Ackerman steering Gear

- The Ackerman steering gear mechanism is much simpler than Davis gear. The difference between the Ackerman and Davis steering gears are :
 - 1 The whole mechanism of the Ackerman steering gear is on back of the front wheels; whereas in Davis steering gear, it is in front of the wheels.
 - 2 The Ackerman steering gear consists of turning pairs, whereas Davis steering gear consists of sliding members.

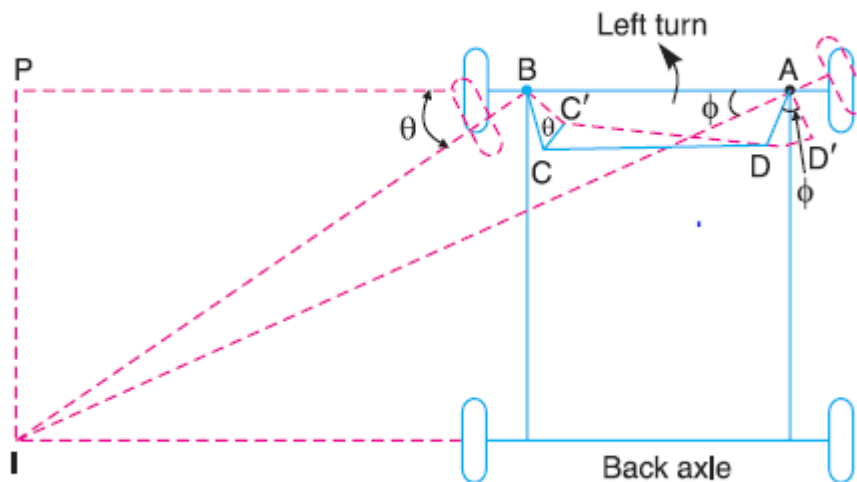

Fig. 4.12 Ackerman steering mechanism

- In Ackerman steering gear, the mechanism ABCD is a four bar crank chain, as shown in Fig. 4.12. The shorter links BC and AD are of equal length and are connected by hinge joints with front wheel axles. The longer links AB and CD are of unequal length.
- The following are the only three positions for correct steering.
 - 1 When the vehicle moves along a straight path, the longer links AB and CD are parallel and the shorter links BC and AD are equally inclined to the longitudinal axis of the vehicle, as shown by firm lines in Fig. 4.12.
 - 2 When the vehicle is steering to the left, the position of the gear is shown by dotted lines in Fig. 4.12. In this position, the lines of the front wheel axle intersect on the back wheel axle at I, for correct steering.
 - 3 When the vehicle is steering to the right, the similar position may be obtained.

Universal or Hooke's Joint

- A Hooke's joint is used to connect two shafts, which are intersecting at a small angle, as shown in Fig.4.10. The end of each shaft is forked to U-type and each fork provides two bearings for the arms of a cross.
- The arms of the cross are perpendicular to each other. The motion is transmitted from the driving shaft to driven shaft through a cross.

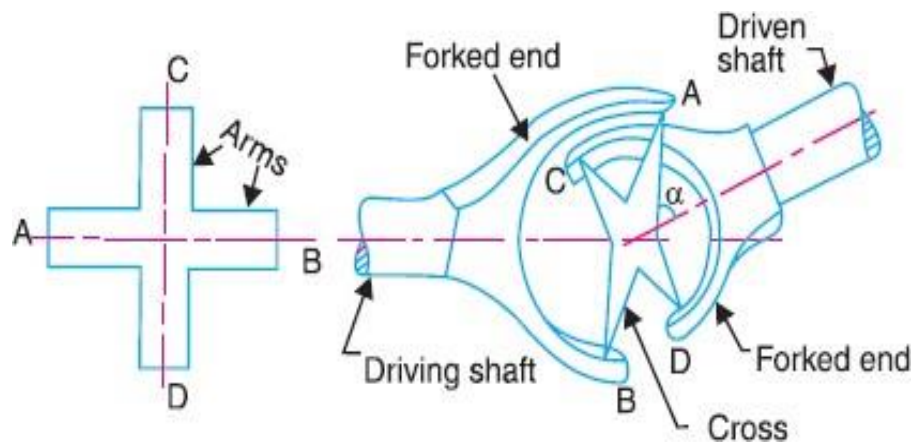

Fig. 4.13 Hooke's Joint

- The main application of the Universal or Hooke's joint is found in the transmission from the gear box to the differential or back axle of the automobiles. It is also used for transmission of power to different spindles of multiple drilling machines.

Ratio of shaft velocities

- The top and front views connecting the two shafts by a universal joint are shown in Fig. 4.11. Let the initial position of the cross be such that both arms lie in the plane of the paper in front view, while the arm AB attached to the driving shaft lies in the plane containing the axes of the two shafts.
- Let the driving shaft rotate through an angle θ , so that the arm AB moves in a circle to a new position A1 B1 as shown in front view.
- A little consideration will show that the arm CD will also move in a circle of the same size. This circle when projected in the plane of paper appears to be an ellipse. Therefore the arm CD takes new position C1D1 on the ellipse, at an angle θ . But the true angle must be on the circular path.
- To find the true angle, project the point C1 horizontally to intersect the circle at C2. Therefore the angle COC2 (equal to ϕ) is the true angle turned by the driven shaft.

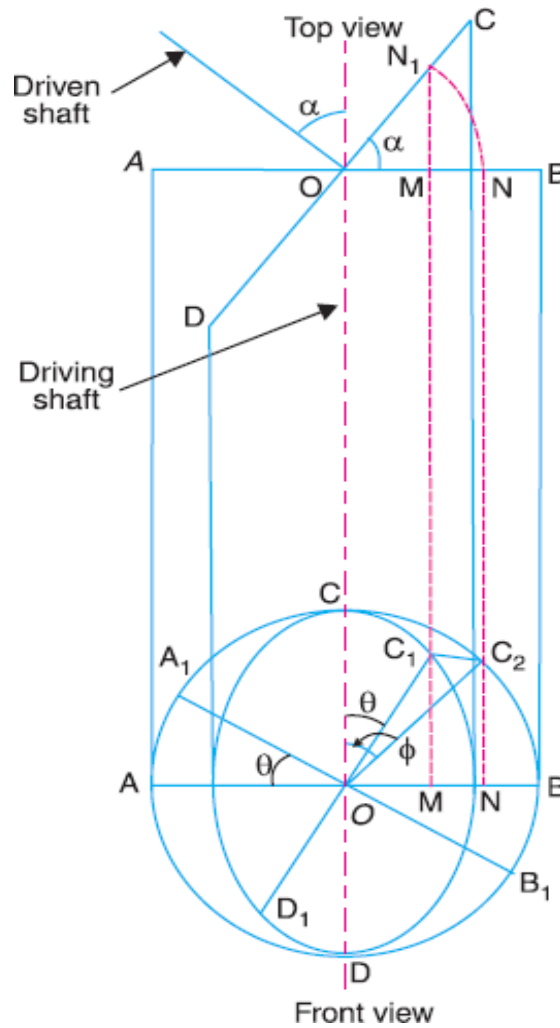

Fig. 4.14 ration of shaft velocities

- In triangle OC₁M, angle OC₁M = θ

$$\tan \theta = \frac{OM}{MC_1} \dots \dots \dots (i)$$

- In triangle OC₂N, angle OC₂N = φ

$$\tan \phi = \frac{ON}{NC_2} = \frac{ON}{MC_1} \dots \dots \dots (ii) \quad (NC_2 = MC_1)$$

- Dividing eq. (i) by (ii)

$$\tan \theta = \frac{OM}{ON} = \frac{OM}{ON}$$

- But

$$OM = N_1 \cos \alpha = ON \cos \alpha \quad (\alpha = \text{angle of inclination of driving and driven shaft})$$

$$\frac{\tan \theta}{\tan \phi} = \frac{ON \cos \alpha}{ON} = \cos \alpha$$

$$\tan \theta = \tan \phi \times \cos \alpha \dots \dots \dots (iii)$$

- Let,

$$\omega = \text{angular velocity of driving shaft} = \frac{d\theta}{dt}$$

$$\omega_1 = \text{angular velocity of driven shaft} = \frac{d\phi}{dt}$$

- Differentiating both side of eq. (iii)

$$\sec^2 \theta \times \frac{d\theta}{dt} = \cos \alpha \times \sec^2 \phi \times \frac{d\phi}{dt}$$

$$\sec^2 \theta \times \omega = \cos \alpha \times \sec^2 \phi \times \omega_1$$

$$\frac{\omega_1}{\omega} = \frac{\sec^2 \theta}{\cos \alpha \times \sec^2 \phi}$$

$$= \frac{1}{\cos^2 \theta \times \cos \alpha \times \sec^2 \phi} \dots \dots (iv)$$

- We know that,

$$\sec^2 \phi = 1 + \tan^2 \phi = 1 + \frac{\tan^2 \theta}{\cos^2 \alpha}$$

$$= 1 + \frac{\sin^2 \theta}{\cos^2 \theta \times \cos^2 \alpha}$$

$$= \frac{\cos^2 \theta \times \cos^2 \alpha + \sin^2 \theta}{\cos^2 \theta \times \cos^2 \alpha}$$

$$= \frac{\cos^2 \theta \times (1 - \sin^2 \alpha) + \sin^2 \theta}{\cos^2 \theta \times \cos^2 \alpha}$$

$$= \frac{\cos^2 \theta - \sin^2 \alpha \times \cos^2 \theta + \sin^2 \theta}{\cos^2 \theta \times \cos^2 \alpha}$$

$$= \frac{1 - \sin^2 \alpha \times \cos^2 \theta}{\cos^2 \theta \times \cos^2 \alpha}$$

- Substituting this value in eq. (iv)

$$\frac{\omega_1}{\omega} = \frac{1}{\cos^2 \theta \times \cos \alpha} \times \frac{\cos^2 \theta \times \cos^2 \alpha}{1 - \sin^2 \alpha \times \cos^2 \theta}$$

Maximum and Minimum speed of Driven Shaft

$$\frac{\omega_1}{\omega} = \frac{\cos \alpha}{1 - \sin^2 \alpha \times \cos^2 \theta}$$

$$\omega_1 = \frac{\omega \times \cos \alpha}{1 - \sin^2 \alpha \times \cos^2 \theta} \dots \dots \dots (i)$$

- The value of ω_1 will be minimum for a given value of α , if the denominator of eq. (I) is minimum.

$$\cos^2 \theta = 1, \text{ i.e. } \theta = 0^\circ, 180^\circ, 360^\circ \text{ etc.}$$

- Maximum speed of the driven shaft,

$$\omega_{1(\max)} = \frac{\omega \cos \alpha}{1 - \sin^2 \alpha} = \frac{\omega \times \cos \alpha}{\cos^2 \alpha} = \frac{\omega}{\cos \alpha}$$

$$N_{1(\max)} = \frac{N}{\cos}$$

- Similarly, the value of ω_1 is minimum, if the denominator of eq. (i) is maximum, this will happen, when $(\sin^2 \alpha \times \cos^2 \theta)$ is maximum, or

$$\cos^2 \theta = 0, \text{ i.e. } \theta = 90^\circ, 270^\circ \text{ etc.}$$

Polar diagram – salient features of driven shaft speed

- For one complete revolution of the driven shaft, there are two points i.e. at 0° and 180° as shown by points 1 and 2 in Fig. Where the speed of the driven shaft is maximum and there are two points i.e. at 90° and 270° as shown by point 3 and 4 where the speed of the driven shaft is minimum.

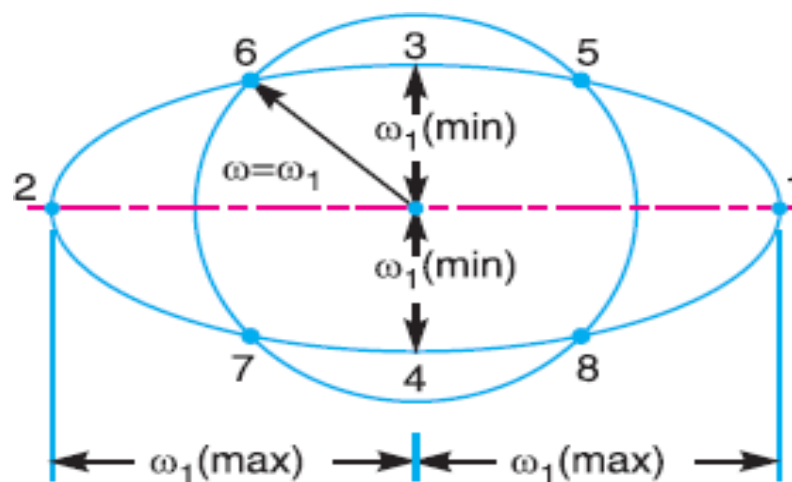

Fig. 4.15 polar diagram

- Since there are two maximum and two minimum speeds of the driven shaft, therefore there are four points when the speeds of the driven and driver shaft are same. This is shown by points, 5, 6, 7 and 8 in Fig.
- Since the angular velocity of the driving shaft is usually constant, therefore it is represented by a circle of radius ω . The driven shaft has a variation in angular velocity, the maximum value being $\omega/\cos \alpha$ and minimum value is $\omega \cos \alpha$. Thus it is represented by an ellipse of semi-major axis $\omega/\cos \alpha$ and semi-minor axis $\omega \cos \alpha$, as shown in Fig.4.15.

Double Hooke's Joint

- The velocity of the driven shaft is not constant, but varies from maximum to minimum values. In order to have a constant velocity ratio of the driving and driven shafts, an intermediate shaft with a Hooke's joint at each end as shown in Fig. , is used. This type of joint is known as double Hooke's joint.

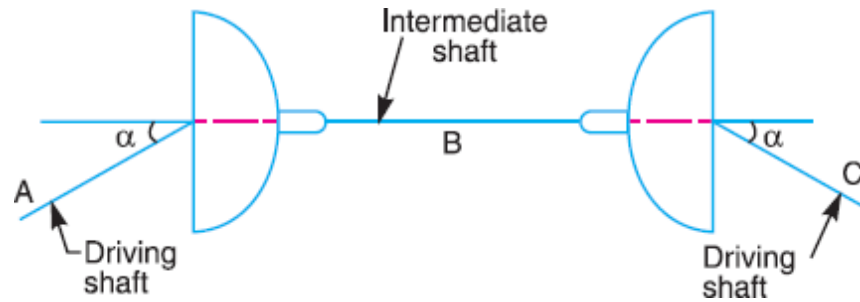

Fig. 4.16 double Hooke's joint

- For shaft A and B, $\tan \theta = \tan \phi \times \cos \alpha$
- For shaft B and C, $\tan \gamma = \tan \phi \times \cos \alpha$
- This shows that the speed of the driving and driven shaft is constant. In other words, this joint gives a velocity ratio equal to unity, if
 - 1 The axes of the driving and driven shafts are in the same plane, and
 - 2 The driving and driven shafts make equal angles with the intermediate shaft.

Examples:

1. In a Davis steering gear, the distance between the pivots of the front axle is 1.2 metres and the wheel base is 4.7 metres. Find the inclination of the track arm to the longitudinal axis of the car, when it is moving along a straight path .

- **Given:** $c = 1.2 \text{ m}$; $b = 4.7 \text{ m}$
- Let, $\alpha =$ Inclination of the track arm to the longitudinal axis.
- We know that

$$\tan \alpha = \frac{c}{2b} = \frac{1.2}{2 \times 4.7} = 0.222$$

$$= 14.5^\circ$$

2. Two shafts with an included angle of 160° are connected by a Hooke's joint. The driving shaft runs at a uniform speed of 1500 r.p.m. The driven shaft carries a flywheel of mass 12 kg and 100 mm radius of gyration. Find the maximum angular acceleration of the driven shaft and the maximum torque required .

- **Given:** $N = 1500 \text{ rpm}$; $m = 12 \text{ kg}$; $k = 100 \text{ mm}$; $\alpha = 20^\circ$
- We know that angular speed of driving shaft,

$$\omega = 2\pi \frac{1500}{60} = 157 \frac{\text{rad}}{\text{s}}$$

- The mass moment of inertia of the driven shaft,

$$I = m \times K^2 = 12 \times 0.1^2 = 0.12 \text{ kg. m}$$

Max. angular acceleration of driven shaft,

$$\cos 2\theta = \frac{\sin^2 \alpha \times 2}{2 - \sin^2 \alpha} = \frac{\sin^2 20 \times 2}{2 - \sin^2 20} = 0.124$$

$$= 41.45^\circ$$

$$\frac{d\omega_1}{dt} = \frac{\omega^2 \times \cos \alpha \times \sin 2\theta \times \sin^2 \alpha}{(1 - \sin^2 \alpha \times \cos^2 \theta)^2}$$

$$= \frac{157^2 \times \cos 20 \times \sin 84.9 \times \sin^2 20}{(1 - \sin^2 20 \times \cos^2 44.45)^2} = 3090 \frac{\text{rad}}{\text{s}^2}$$

– Max torque req.

$$= I \times \frac{d\omega_1}{dt} = 0.12 \times 3090 = 371 \text{ N. m}$$

References

1. Theory of Machines by S.S.Rattan, Tata McGraw Hill publication.
2. Theory of Machines by R.S. Khurmi & J.K.Gupta,S.Chand publication.

3

Velocity and Acceleration Analysis

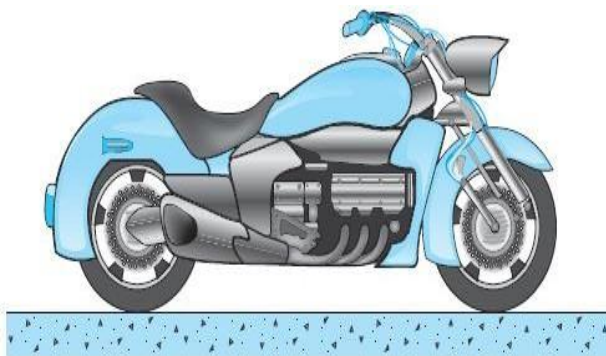

Course Contents

- 3.1 Introduction
- 3.2 Velocity of Two Bodies Moving In Straight Lines
- 3.3 Motion of A Link
- 3.4 Velocity of A Point On A Link By Relative Velocity Method
- 3.5 Velocities in Slider Crank Mechanism
- 3.6 Rubbing Velocity at A Pin Joint
- 3.7 Examples Based On Velocity
- 3.8 Velocity of A Point On A Link By Instantaneous Centre Method
- 3.9 Properties of Instantaneous Method
- 3.10 Number of Instantaneous Centre In A Mechanism
- 3.11 Types of Instantaneous Centers
- 3.12 Kennedy's Theorem
- 3.13 Acceleration Diagram for a Link
- 3.14 Acceleration of a Point on a Link
- 3.15 Acceleration in Slider Crank Mechanism
- 3.16 Examples Based on Acceleration

3.1 Introduction

- There are many methods for determining the velocity of any point on a link in a mechanism whose direction of motion (i.e. path) and velocity of some other point on the same link is known in magnitude and direction, yet the following two methods :
 - 1 Instantaneous centre method
 - 2 Relative velocity method
- The instantaneous centre method is convenient and easy to apply in simple mechanisms, whereas the relative velocity method may be used to any configuration diagram.

3.2 Velocity Of Two Bodies Moving In Straight Lines

- Here we shall discuss the application of vectors for the relative velocity of two bodies moving along parallel lines and inclined lines, as shown in Fig. 2.1 (a) and 2.2 (a) respectively.
- Consider two bodies A and B moving along parallel lines in the same direction with absolute velocities v_A and v_B such that $v_A > v_B$, as shown in Fig. 2.1 (a). The relative velocity of A with respect to B,

$$v_{AB} = \text{vector difference of } v_A \text{ and } v_B = \vec{v_A} - \vec{v_B}$$

- From Fig. 2.1 (b), the relative velocity of A with respect to B (i.e. v_{AB}) may be written in the vector form as follows :

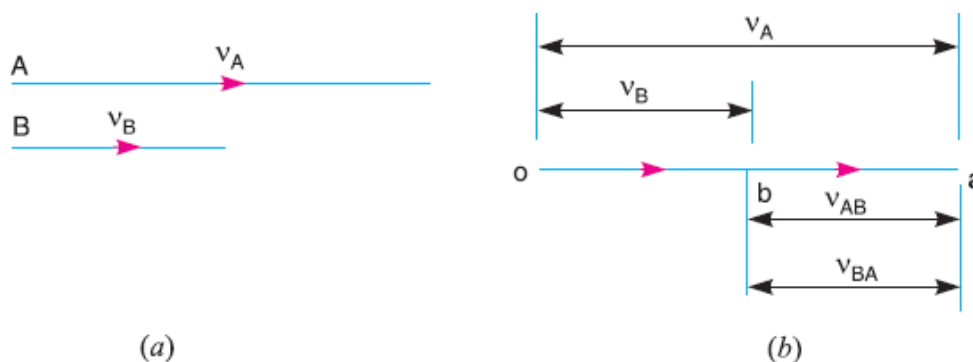

Fig. 3.1 relative velocity of two bodies moving along parallel line

- Similarly, the relative velocity of B with respect to A,

$$v_{BA} = \text{vector difference of } v_A \text{ and } v_B$$
- Now consider the body B moving in an inclined direction as shown in Fig. 2.2 (a). The relative velocity of A with respect to B may be obtained by the law of parallelogram of velocities or triangle law of velocities. Take any fixed point o and draw vector oa to represent v_A in magnitude and direction to some suitable scale. Similarly, draw vector ob to represent v_B in magnitude and direction to the same scale. Then vector ba represents the relative velocity of A with respect to B as shown in Fig. 7.2 (b). In the

similar way as discussed above, the relative velocity of A with respect to B,

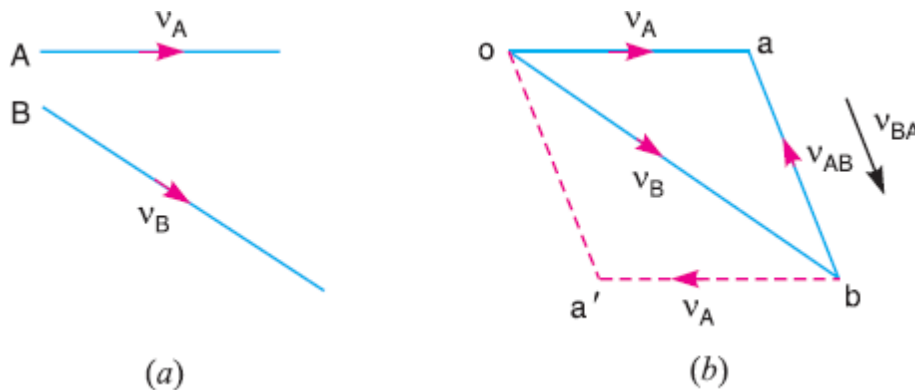

Fig. 3.2 relative velocity of two bodies moving along inclined line

$$v_{AB} = \text{vector difference of } v_A \text{ and } v_B$$

- Similarly, the relative velocity of B with respect to A

$$v_{BA} = \text{vector difference of } v_B \text{ and } v_A$$

- From above, we conclude that the relative velocity of a point A with respect to B (v_{AB}) and the relative velocity of point B with respect to A (v_{BA}) are equal in magnitude but opposite in direction

$$v_{AB} = -v_{BA}$$

3.3 Motion Of A Link

- Consider two points A and B on a rigid link A B, as shown in Fig. 2.3 (a). Let one of the extremities (B) of the link move relative to A, in a clockwise direction. Since the distance from A to B remains the same, therefore there can be no relative motion between A and B, along the line AB. It is thus obvious, that the relative motion of B with respect to A must be perpendicular to AB.
- Hence velocity of any point on a link with respect to another point on the same link is always perpendicular to the line joining these points on the configuration (or space) diagram.
- The relative velocity of B with respect to A (i.e. v_{BA}) is represented by the vector ab and is perpendicular to the line A B as shown in Fig. 2.3 (b).

- We know that the velocity of the point B with respect to A

$$v_{BA} = \omega \times AB \dots \dots \dots (i)$$

- Similarly the velocity of the point C on AB with respect to A

$$v_{CA} = \omega \times AC \dots \dots \dots (ii)$$

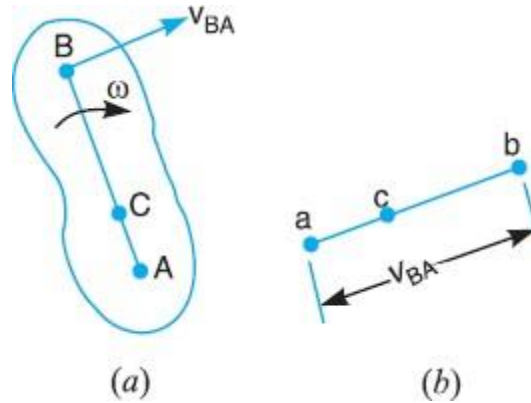

Fig. 3.3 Motion of a Link

- Form equation (i) and (ii),

$$\frac{v_{cA}}{v_{BA}} = \frac{\omega \times AC}{\omega \times AB} = \frac{AC}{AB} \dots \dots \dots (iii)$$
- Thus, we see from equation (iii), that the point c on the vector ab divides it in the same ratio as C divides the link AB.

3.4 Velocity Of A Point On A Link By Relative Velocity Method

- Consider two points A and B on a link as shown in Fig. 2.4 (a). Let the absolute velocity of the point A i.e. v_A is known in magnitude and direction and the absolute velocity of the point B i.e. v_B is known in direction only. Then the velocity of B may be determined by drawing the velocity diagram as shown in Fig. 2.4 (b). The velocity diagram is drawn as follows :
 - 1 Take some convenient point o, known as the pole.
 - 2 Through o, draw oa parallel and equal to v_A , to some suitable scale.
 - 3 Through a, draw a line perpendicular to AB of Fig. 2.4 (a). This line will represent the velocity of B with respect to A, i.e. v_{BA} .
 - 4 Through o, draw a line parallel to v_B intersecting the line of v_{BA} at b
 - 5 Measure ob, which gives the required velocity of point B (v_B), to the scale

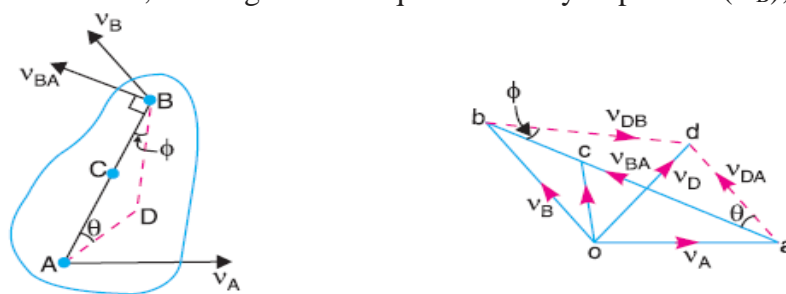

(a) Motion of points on a link. (b) Velocity diagram.

Fig. 3.4

3.5 Velocities In Slider Crank Mechanism

- In the previous article, we have discussed the relative velocity method for the velocity of any point on a link, whose direction of motion and velocity of some other point on the same link is known. The same method may also be applied for the velocities in a slider crank mechanism.
- A slider crank mechanism is shown in Fig. 2.5 (a). The slider A is attached to the connecting rod AB. Let the radius of crank OB be r and let it rotate in a clockwise direction, about the point O with uniform angular velocity ω rad/s. Therefore, the velocity of B i.e. v_B is known in magnitude and direction. The slider reciprocates along the line of stroke AO.

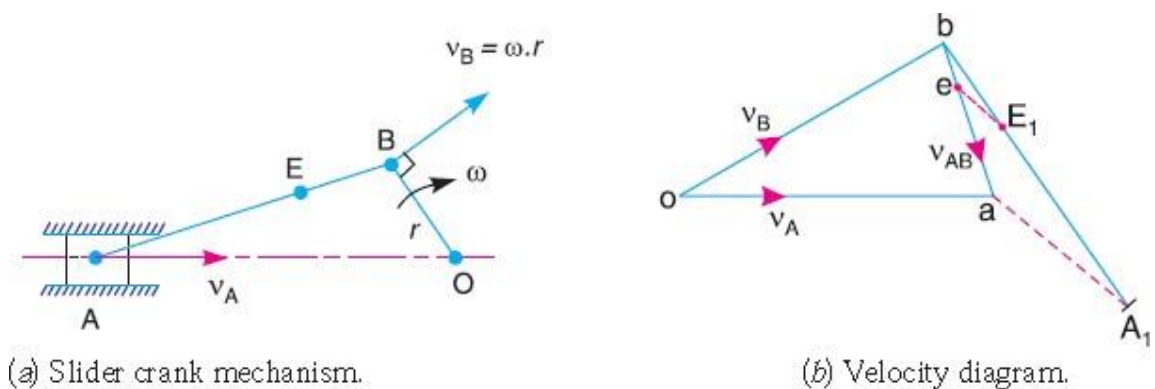

Fig. 3.5

- The velocity of the slider A (i.e. v_A) may be determined by relative velocity method as discussed below :
 - 1 From any point o , draw vector ob parallel to the direction of v_B (or perpendicular to OB) such that $ob = v_B = \omega.r$, to some suitable scale, as shown in Fig. 2.5 (b).
 - 2 Since AB is a rigid link, therefore the velocity of A relative to B is perpendicular to AB . Now draw vector ba perpendicular to AB to represent the velocity of A with respect to B i.e. v_{AB} .
 - 3 From point o , draw vector oa parallel to the path of motion of the slider A (which is along AO only). The vectors ba and oa intersect at a . Now oa represents the velocity of the slider i.e. v_A , to the scale.
- The angular velocity of the connecting rod AB (ω_{AB}) may be determined as follows:

$$\omega_{AB} = \frac{v_{BA}}{AB} = \frac{ab}{AB}$$

3.6 Rubbing Velocity At A Pin Joint

- The links in a mechanism are mostly connected by means of pin joints. The rubbing velocity is defined as the algebraic sum between the angular velocities of the two links which are connected by pin joints, multiplied by the radius of the pin.
- Consider two links OA and OB connected by a pin joint at O as shown in fig.

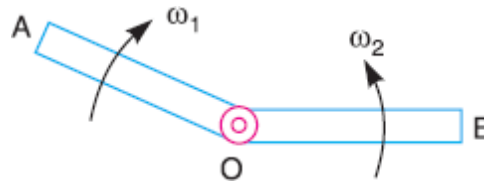

Fig. 3.6 Links connected by pin joints

- Let,
 ω_1 = angular velocity of link OA
 ω_2 = angular velocity of link OB
- According to the definition,
- Rubbing velocity at the pin joint O
 - = $(\omega_1 - \omega_2) \times r$ if the links move in the same direction
 - = $(\omega_1 + \omega_2) \times r$ if the links move in opposite directions

3.7 Examples Based On Velocity

3.7.1 In a four bar chain ABCD, AD is fixed and is 150 mm long. The crank AB is 40 mm long and rotates at 120 r.p.m. clockwise, while the link CD = 80 mm oscillates about D. BC and AD are of equal length. Find the angular velocity of link CD when angle BAD = 60°.

- **Given :** $N_{BA} = 120$ r.p.m. or $\omega_{BA} = 2\pi \times 120/60 = 12.568$ rad/s
- Since the length of crank AB = 40 mm = 0.04 m, therefore velocity of B with respect to A or velocity of B, (because A is a fixed point),
- Since the length of crank AB = 40 mm = 0.04 m, therefore velocity of B with respect to A or velocity of B, (because A is a fixed point),

$$v_{BA} = v_B = \omega_{BA} \times AB = 12.568 \times 0.04 = 0.503 \text{ m/s}$$
- Since the link AD is fixed, therefore points a and d are taken as one point in the velocity diagram. Draw vector ab perpendicular to BA, to some suitable scale, to represent the velocity of B with respect to A or simply velocity of B (i.e. v_{BA} or v_B) such that

$$\text{Vector } ab = v_{BA} = v_B = 0.503 \text{ m/s}$$

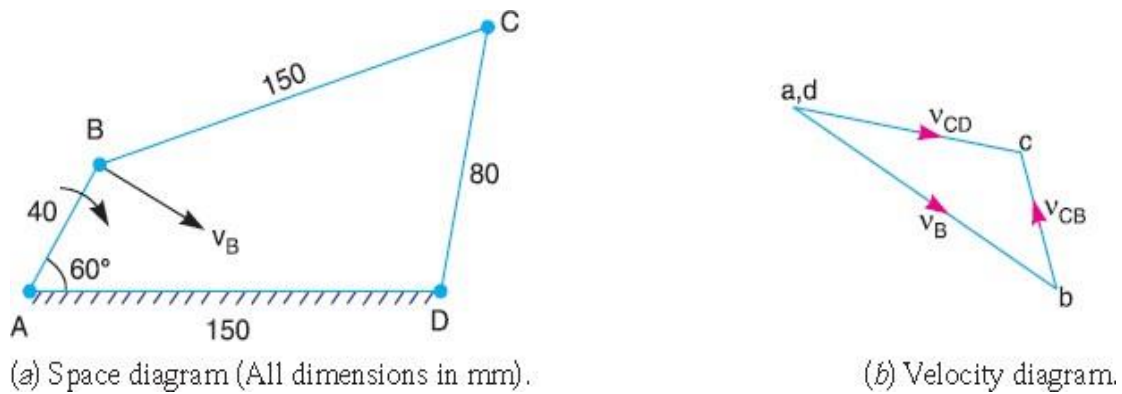

Fig. 3.7

- Now from point b, draw vector bc perpendicular to CB to represent the velocity of C with respect to B (i.e. v_{CB}) and from point d, draw vector dc perpendicular to CD to represent the velocity of C with respect to D or simply velocity of C (i.e. v_{CD} or v_C). The vectors bc and dc intersect at c.

By measurement, we find that

$$V_{CD} = v_C = \text{vector dc} = 0.385 \text{ m/s}$$

- Angular velocity of link CD,

$$\omega_{CD} = \frac{v_{CD}}{CD} = \frac{0.385}{0.08} = 4.8 \text{ rad/s}$$

3.72 The crank and connecting rod of a theoretical steam engine are 0.5 m and 2 m long respectively. The crank makes 180 r.p.m. in the clockwise direction. When it has turned 45° from the inner dead centre position, determine:

1. Velocity of piston,
2. Angular velocity of connecting rod,
3. Velocity of point E on the connecting rod 1.5 m from the gudgeon pin,
4. velocities of rubbing at the pins of the crank shaft, crank and crosshead when the diameters of their pins are 50 mm, 60 mm and 30 mm respectively,
5. Position and linear velocity of any point G on the connecting rod which has the least velocity relative to crank shaft.

— **Given:**

- $N_{BO} = 180 \text{ r.p.m.}$ or $\omega_{BO} = 2\pi \times 180/60 = 18.852 \text{ rad/s}$
- Since the crank length $OB = 0.5 \text{ m}$, therefore linear velocity of B with respect to O or velocity of B (because O is a fixed point),

$$v_{BO} = v_B = \omega_{BO} \times OB = 18.852 \times 0.5 = 9.426 \text{ m/s}$$

- First of all draw the space diagram and then draw the velocity diagram as shown in fig.

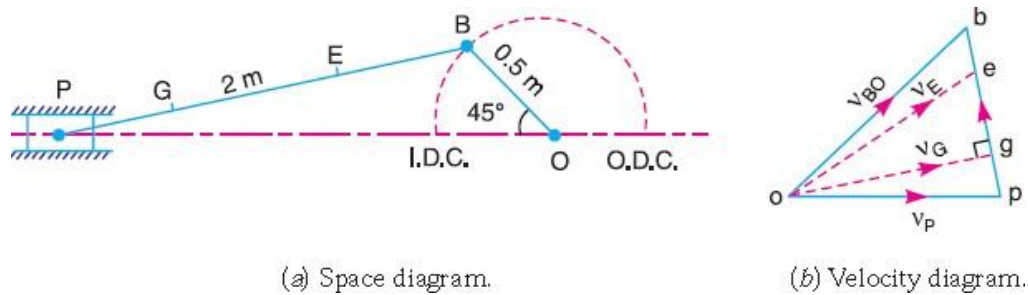

Fig. 3.8

- By measurement, we find that velocity of piston P,

$$v_P = \text{vector } op = 8.15 \text{ m/s}$$
- From the velocity diagram, we find that the velocity of P with respect to B

$$v_{PB} = \text{vector } bp = 6.8 \text{ m/s}$$
- Since the length of connecting rod PB is 2 m, therefore angular velocity of the connecting rod,

$$\omega_{PB} = \frac{v_{PB}}{PB} = \frac{6.8}{2} = 3.4 \text{ rad/s}$$

$$v_E = \text{vector } oe = 8.5 \text{ m/s}$$

- We know that velocity of rubbing at the pin of crank-shaft

$$= \frac{d_o}{2} \times \omega_{BO} = 0.47 \text{ m/s}$$

- Velocity of rubbing at the pin of crank

$$= \frac{d_B}{2} (\omega_{BO} + \omega_{PB}) = 0.6675 \text{ m/s}$$

- Velocity of rubbing at the pin of crank

$$= \frac{d_c}{2} \times \omega_{PB} = 0.051 \text{ m/s}$$

- By measurement we find that

$$\text{vector } bg = 5 \text{ m/s}$$

- By measurement we find linear velocity of point G

$$v_G = \text{vector } og = 8 \text{ m/s}$$

3.73 In Fig. , the angular velocity of the crank OA is 600 r.p.m. Determine the linear velocity of the slider D and the angular velocity of the link BD, when the crank is inclined at an angle of 75° to the vertical. The dimensions of various links are: OA = 28 mm; AB = 44 mm; BC 49 mm; and BD = 46 mm. The centre distance between the canters of rotation O and C is 65 mm. The path of travel of the slider is 11 mm below the fixed point C. The slider moves along a horizontal path and OC is vertical.

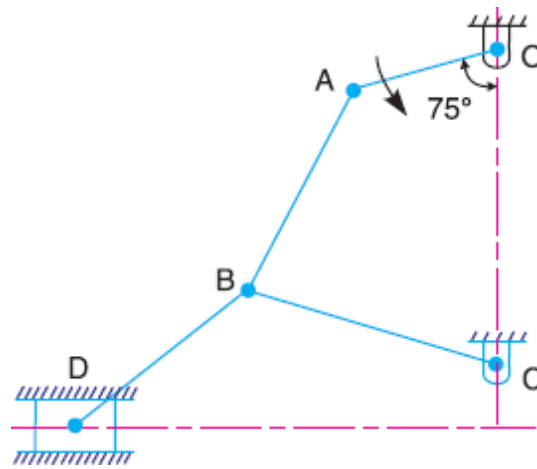

Fig. 3.9

– **Given**

∴

– $N_{AO} = 180$ r.p.m. or $\omega_{BO} = 2\pi \times 180/60 = 18.852$ rad/s

– $OA = 28$ mm

$$v_{OA} = v_A = \omega_{AO} \times AO = 1.76 \text{ m/s}$$

- Since the points O and C are fixed, therefore these points are marked as one point, in the velocity diagram. Now from point o, draw vector oa perpendicular to OA, to some suitable scale, to represent the velocity of A with respect to O or simply velocity of A such that

$$\text{vector } oa = v_{OA} = v_A = 1.76 \text{ m/s}$$

- From point a, draw vector ab perpendicular to AB to represent the velocity of B with respect to A (i.e. v_{BA}) and from point c, draw vector cb perpendicular to CB to represent the velocity of B with respect to C or simply velocity of B (i.e. v_{BC} or v_B). The vectors ab and cb intersect at b.
- From point b, draw vector bd perpendicular to BD to represent the velocity of D with respect to B (i.e. v_{DB}) and from point o, draw vector od parallel to the path of motion of the slider D which is horizontal, to represent the velocity of D (i.e. v_D). The vectors bd and od intersect at d.

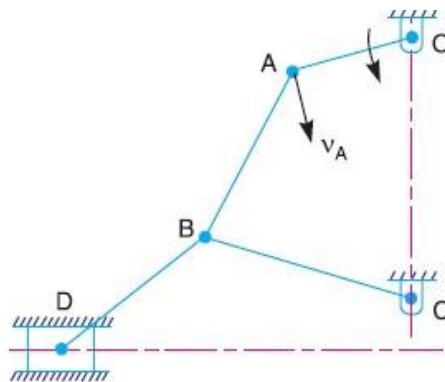

(a) Space diagram.

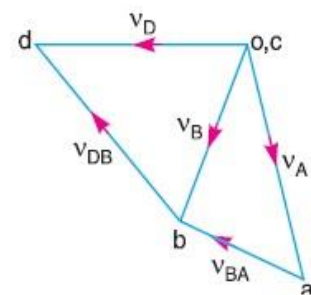

(b) Velocity diagram.

Fig.3.10

- By measurement, we find that velocity of slider D,

$$v_D = \text{vector } od = 1.6 \text{ m/s}$$

- By measurement from velocity diagram, we find that velocity of D with respect to B,

$$v_{DB} = \text{vector } bd = 1.7 \text{ m/s}$$

- Therefore angular velocity of link BD

$$\omega_{BD} = \frac{v_{DB}}{BD} = \frac{1.7}{0.046} = 36.96 \text{ rad/s}$$

3.74 The mechanism, as shown in Fig. 7.11, has the dimensions of various links as follows :

AB = DE = 150 mm; BC = CD = 450 mm; EF = 375 mm. The crank AB makes an angle of

45° with the horizontal and rotates about A in the clockwise direction at a uniform speed of 120 r.p.m. The lever DC oscillates about the fixed point D, which is connected to AB by the coupler BC.

The block F moves in the horizontal guides, being driven by the link EF. Determine: 1. velocity of the block F, 2. angular velocity of DC, and 3. rubbing speed at the pin C which is 50 mm in diameter.

- Given :

- $N_{BA} = 120 \text{ r.p.m.}$ or $\omega_{BA} = 2\pi \times 120/60 = 4\pi \text{ rad/s}$

- Since the crank length A B = 150 mm = 0.15 m, therefore velocity of B with respect to A or simply velocity of B (because A is a fixed point),

$$v_{BA} = v_B = \omega_{BA} \times AB = 4\pi \times 0.15 = 1.885 \text{ m/s}$$

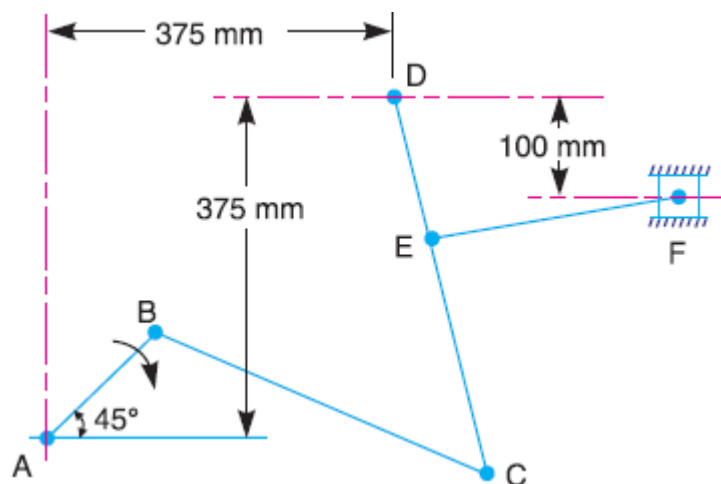

Fig.3.11

- Since the points A and D are fixed, therefore these points are marked as one point as shown in Fig. (b). Now from point a, draw vector ab perpendicular to AB,

to some suitable scale, to represent the velocity of B with respect to A or simply velocity of B, such that

$$\text{Vector } ab = v_{BA} = v_B = 1.885 \text{ m/s}$$

- The point C moves relative to B and D, therefore draw vector bc perpendicular to BC to represent the velocity of C with respect to B (i.e. v_{CB}), and from point d , draw vector dc perpendicular to DC to represent the velocity of C with respect to D or simply velocity of C (i.e. v_{CD} or v_C). The vectors bc and dc intersect at c .

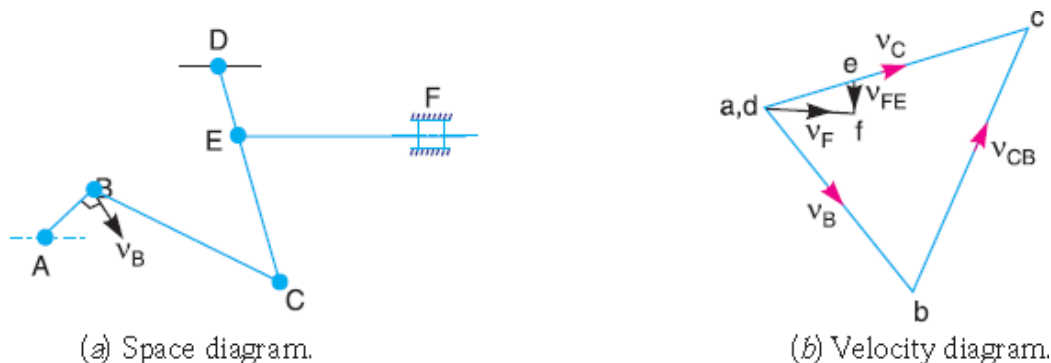

Fig. 3.12

- Since the point E lies on DC , therefore divide vector dc in e in the same ratio as E divides CD in Fig. (a). In other words

$$ce/cd = CE/CD$$

- From point e , draw vector ef perpendicular to EF to represent the velocity of F with respect to E (i.e. v_{FE}) and from point d draw vector df parallel to the path of motion of F , which is horizontal, to represent the velocity of F i.e. v_F . The vectors ef and df intersect at f .

$$v_F = \text{vector } df = 0.7 \text{ m/s}$$

- By measurement from velocity diagram, we find that velocity of C with respect to D ,

$$v_{CD} = \text{vector } dc = 2.25 \text{ m/s}$$

$$\omega_{DC} = \frac{v_{CD}}{DC} = 5 \frac{\text{rad}}{\text{s}}$$

- From velocity diagram, we find that velocity of C with respect to B ,

$$v_{CB} = \text{vector } bc = 2.25 \text{ m/s}$$

- Angular velocity of BC ,

$$\omega_{CD} = \frac{v_{CD}}{BC} = \frac{2.25}{0.45} = 5 \text{ rad/s}$$

3.8 Velocity Of A Point On A Link By Instantaneous Centre Method

- The instantaneous centre method of analyzing the motion in a mechanism is based upon the concept that any displacement of a body (or a rigid link) having motion in one plane, can be considered as a pure rotational motion of a rigid link as a whole about some centre, known as instantaneous centre or virtual centre of rotation.

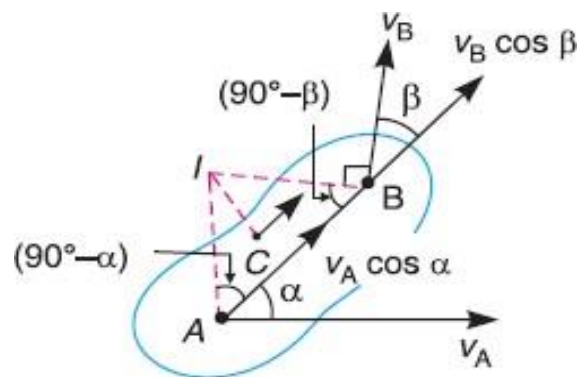

Fig. 3.13 velocity of a point on a link

- The velocities of points A and B, whose directions are given a link by angles α and β as shown in Fig. If v_A is known in magnitude and direction and v_B in direction only, then the magnitude of v_B may be determined by the instantaneous centre method as discussed below :
- Draw AI and BI perpendiculars to the directions v_A and v_B respectively. Let these lines intersect at I, which is known as instantaneous centre or virtual centre of the link. The complete rigid link is to rotate or turn about the centre I.
- Since A and B are the points on a rigid link, therefore there cannot be any relative motion between them along line AB.
- Now resolving the velocities along AB,

$$\frac{v_A}{v_B} = \frac{\cos \beta}{\cos \alpha} = \frac{\sin(90 - \beta)}{\sin(90 - \alpha)} \dots \dots \dots (i)$$

- Applying Lami's theorem to triangle ABI,

$$\frac{AI}{\sin(90 - \beta)} = \frac{BI}{\sin(90 - \alpha)}$$

$$\frac{AI}{BI} = \frac{\sin(90 - \beta)}{\sin(90 - \alpha)} \dots \dots \dots (ii)$$

- Hence,

$$\frac{v_A}{v_B} = \frac{AI}{BI}$$

$$\frac{v_A}{AI} = \frac{v_B}{BI} = \omega \dots \dots \dots (iii)$$

- If C is any other point on link, then

$$\frac{v_A}{AI} = \frac{v_B}{BI} = \frac{v_C}{CI} \dots \dots \dots (iv)$$

3.9 Properties Of Instantaneous Method

- The following properties of instantaneous centre are important :
- 1 A rigid link rotates instantaneously relative to another link at the instantaneous centre for the configuration of the mechanism considered.
 - 2 The two rigid links have no linear velocity relative to each other at the instantaneous centre. At this point (i.e. instantaneous centre), the two rigid links have the same linear velocity relative to the third rigid link. In other words, the velocity of the instantaneous centre relative to any third rigid link will be same whether the instantaneous centre is regarded as a point on the first rigid link or on the second rigid link

3.10 Number Of Instantaneous Centre In A Mechanism:

- The number of instantaneous centres in a constrained kinematic chain is equal to the number of possible combinations of two links. The number of pairs of links or the number 3 of instantaneous centres is the number of combinations of n links taken two at a time. Mathematically, number of instantaneous centres

$$N = \frac{n(n-1)}{2}, \text{ where } n = \text{Number of Link}$$

3.11 Location of Instantaneous centres:

- The following rules may be used in locating the instantaneous centres in a mechanism :
- 1 When the two links are connected by a pin joint (or pivot joint), the instantaneous centre lies on the centre of the pin as shown in Fig. (a). such an instantaneous centre is of permanent nature, but if one of the links is fixed, the instantaneous centre will be of fixed type.
 - 2 When the two links have a pure rolling contact (i.e. link 2 rolls without slipping upon the fixed link 1 which may be straight or curved), the instantaneous centre lies on their point of contact, as shown in Fig.(b). The velocity of any point A on the link 2 relative to fixed link 1 will be perpendicular to I12 A and is proportional to I12 A.
 - 3 When the two links have a sliding contact, the instantaneous centre lies on the common normal at the point of contact. We shall consider the following three cases :
 - a. When the link 2 (slider) moves on fixed link 1 having straight surface as shown in Fig.(c), the instantaneous centre lies at infinity and each point on the slider have the same velocity.

- b. When the link 2 (slider) moves on fixed link 1 having curved surface as shown in Fig.(d),the instantaneous centre lies on the centre of curvature of the curvilinear path in the configuration at that instant.
- c. When the link 2 (slider) moves on fixed link 1 having constant radius of curvature as shown in Fig. 6.6 (e), the instantaneous centre lies at the centre of curvature i.e. the centre of the circle, for all configuration of the links.

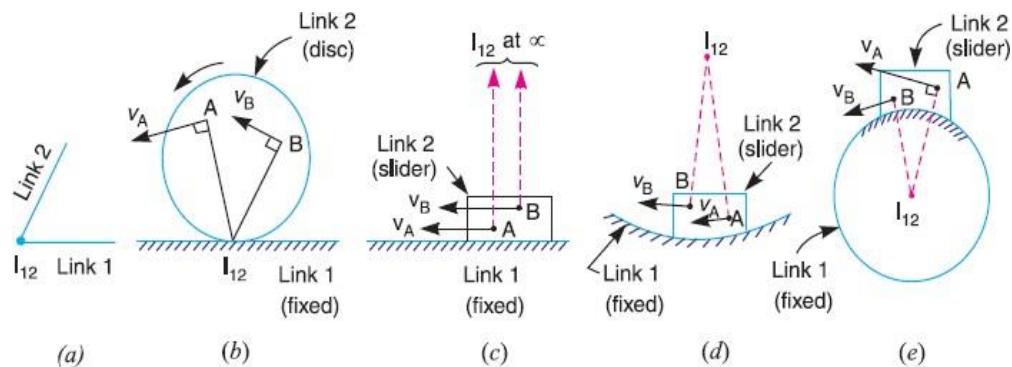

Fig. 3.14 Location of Instantaneous centres

3.12 Kennedy's Theorem

- The Aronhold Kennedy's theorem states that "if three bodies move relatively to each other, they have three instantaneous centres and lie on a straight line."
- Consider three kinematic links A , B and C having relative plane motion. The number of instantaneous centres (N) is given by

$$N = \frac{n(n-1)}{2} = \frac{3(3-1)}{2} = 3$$

- The two instantaneous centres at the pin joints of B with A , and C with A (i.e. I_{ab} and I_{ac}) are the permanent instantaneous centre According to Aronhold Kennedy's theorem, the third instantaneous centre I_{bc} must lie on the line joining I_{ab} and I_{ac} . In order to prove this let us consider that the instantaneous centre I_{bc} lies outside the line joining I_{ab} and I_{ac} as shown in Fig. The point I_{bc} belongs to both the links B and C. Let us consider the point I_{bc} on the link B. Its velocity v_{BC} must be perpendicular to the line joining I_{ab} and I_{bc} . Now consider the point I_{bc} on the link C. Its velocity v_{BC} must be perpendicular to the line joining I_{ac} and I_{bc} .

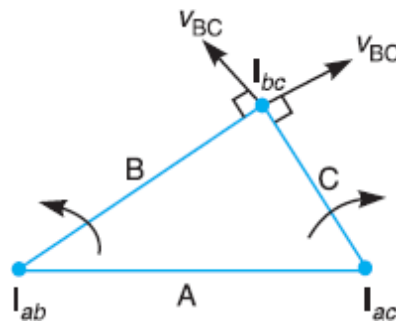

Fig. 3.15 Aronhold Kennedy's theorem

- We have already discussed that the velocity of the instantaneous centre is same whether it is regarded as a point on the first link or as a point on the second link. Therefore, the velocity of the point I_{bc} cannot be perpendicular to both lines $I_{ab} I_{bc}$ and $I_{ac} I_{bc}$ unless the point I_{bc} lies on the line joining the points I_{ab} and I_{ac} . Thus the three instantaneous centres (I_{ab} , I_{ac} and I_{bc}) must lie on the same straight line. The exact location of I_{bc} on line $I_{ab} I_{ac}$ depends upon the directions and magnitudes of the angular velocities of B and C relative to A.

3.13 Acceleration Diagram for a Link

- Consider two points A and B on a rigid link as shown in Fig. (a). Let the point B moves with respect to A, with an angular velocity of ω rad/s and let α rad/s² be the angular acceleration of the link AB.

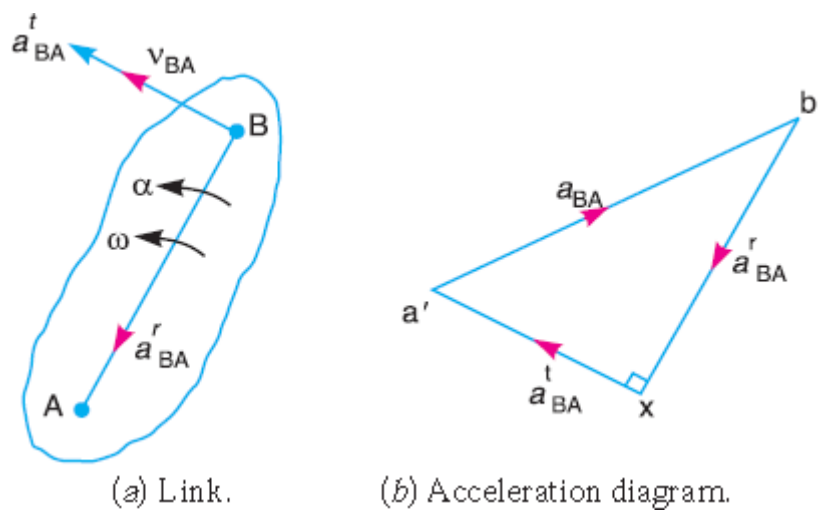

Fig. 3.16 Acceleration of a link

- We have already discussed that acceleration of a particle whose velocity changes both in magnitude and direction at any instant has the following two components .
 - 1 The centripetal or radial component, which is perpendicular to the velocity of the particle at the given instant.
 - 2 The tangential component, which is parallel to the velocity of the particle at the given instant.

- Thus for a link A B, the velocity of point B with respect to A (i.e. v_{BA}) is perpendicular to the link A B as shown in Fig.(a). Since the point B moves with respect to A with an angular velocity of ω rad/s, therefore centripetal or radial component of the acceleration of B with respect to A

$$a_{BA}^r = \omega^2 \times \text{Length of link } AB = \omega^2 \times AB = \frac{v_{BA}^2}{AB}$$

- This radial component of acceleration acts perpendicular to the velocity v_{BA} , In other words, it acts parallel to the link AB.

We know that tangential component of the acceleration of B with respect to A ,

$$a_{BA}^t = \alpha \times \text{Length of link } AB = \alpha \times AB$$

- This tangential component of acceleration acts parallel to the velocity v_{BA} . In other words, it acts perpendicular to the link AB.
- In order to draw the acceleration diagram for a link A B, as shown in Fig. 8.1 (b), from any point b' , draw vector $b'x$ parallel to BA to represent the radial component of acceleration of B with respect to A.

3.14 Acceleration of a Point on a Link

- Consider two points A and B on the rigid link, as shown in Fig. (a). Let the acceleration of the point A i.e. a_A is known in magnitude and direction and the direction of path of B is given. The acceleration of the point B is determined in magnitude and direction by drawing the acceleration diagram as discussed below.

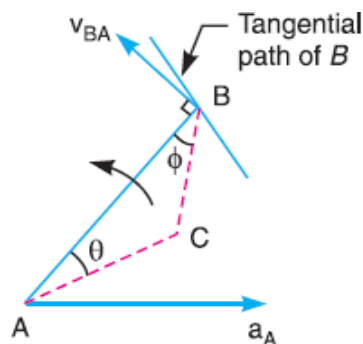

(a) Points on a Link.

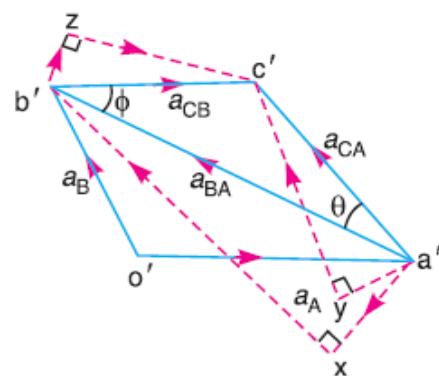

(b) Acceleration diagram.

Fig. 3.17 acceleration of a point on a link

- From any point o' , draw vector $o'a'$ parallel to the direction of absolute acceleration at point A i.e. a_A , to some suitable scale, as shown in Fig. 8.2 (b).
- We know that the acceleration of B with respect to A i.e. a_{BA} has the following two components:
 - 1 Radial component of the acceleration of B with respect to A i.e. a_{BA}^r
 - 2 Tangential component of the acceleration B with respect to A i.e. a_{BA}^t

- Draw vector $a'x$ parallel to the link AB such that,

$$\text{vector } a'x = a_{BA}^r = v_{BA}^2 / AB$$
- From point x, draw vector xb' perpendicular to AB or vector $a'x$ and through o' draw a line parallel to the path of B to represent the absolute acceleration of B i.e. a_B
- By joining the points a' and b' we may determine the total acceleration of B with respect to A i.e. a_{BA} . The vector $a'b'$ is known as acceleration image of the link AB.
- For any other point C on the link, draw triangle $a'b'c'$ similar to triangle ABC. Now vector $b'c'$ represents the acceleration of C with respect to B i.e. a_{CB} , and vector $a'c'$ represents the acceleration of C with respect to A i.e. a_{CA} . As discussed above, a_{CB} and a_{CA} will each have two components as follows :
 - a_{CB} has two components; a_{CB}^r and a_{CB}^t as shown by triangle $b'zc'$ in fig.b
 - a_{CA} has two components; a_{CA}^r and a_{CA}^t as shown by triangle $a'yc'$
- The angular acceleration of the link AB is obtained by dividing the tangential component of acceleration of B with respect to A to the length of the link.

$$\alpha_{AB} = a_{BA}^t / AB$$

3.15 Acceleration in Slider Crank Mechanism

- A slider crank mechanism is shown in Fig. 8.3 (a). Let the crank OB makes an angle θ with the inner dead centre (I.D.C) and rotates in a clockwise direction about the fixed point O with uniform angular velocity ω_{BO} rad/s
- Velocity of B with respect to O or velocity of B (because O is a fixed point),

$$v_{BO} = v_B = \omega_{BO} \times OB \text{ acting tangentially at B}$$
- We know that centripetal or radial acceleration of B with respect to O or acceleration of B (Because O is a fixed point)

$$a_{BO}^r = a_B = \omega_{BO}^2 \times OB = \frac{v_{BO}^2}{BO}$$

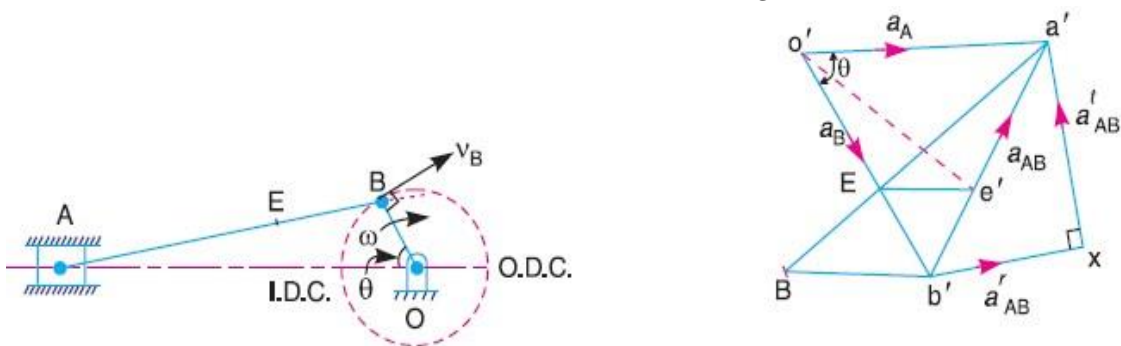

(a) Slider crank mechanism.

(b) Acceleration diagram.

Fig. 3.18 acceleration in the slider crank mechanism

- The acceleration diagram, as shown in Fig. 8.3 (b), may now be drawn as discussed below:

- 1 Draw vector $o'b'$ parallel to BO and set off equal in magnitude of $a=a$, to some BO suitable scale.
- 2 From point b' , draw vector $b'x$ parallel to BA . The vector $b'x$ represents the radial component of the acceleration of A with respect to B whose magnitude is given by :

$$\mathbf{a}_{AB}^r = \mathbf{v}_{AB}^2 / BA$$
- 3 From point x , draw vector xa' perpendicular to $b'x$. The vector xa' represents the tangential components of the acceleration of A with respect to B .
- 4 Since the point A reciprocates along AO , therefore the acceleration must be parallel to velocity. Therefore from o' , draw $o'a'$ parallel to AO , intersecting the vector xa' at a' .
- 5 The vector $b'a'$, which is the sum of the vectors $b'x$ and xa' , represents the total acceleration of A with respect to B i.e. a_{AB} . The vector $b'a'$ represents the acceleration of the connecting rod AB .
- 6 The acceleration of any other point on AB such as E may be obtained by dividing the vector $b'a'$ at e' in the same ratio as E divides AB in Fig. 8.3 (a). In other words

$$\mathbf{a}'e' / \mathbf{a}'b' = AE / AB$$

- 7 The angular acceleration of the connecting rod AB may be obtained by dividing the tangential component of the acceleration of A with respect to B to the length of AB . In other words, angular acceleration of AB ,

$$\alpha_{AB} = \mathbf{a}_{AB}^t / AB$$

3.16 Examples Based on Acceleration

3.16.1 The crank of the slider crank mechanism rotates clockwise at a constant speed of 300 r.p.m. The crank is 150 mm and the connecting rod is 600 mm long. Determine :

1. Linear velocity and acceleration of the midpoint of the connecting rod, and
2. Angular velocity and angular acceleration of the connecting rod, at a crank angle of 45° from inner dead centre position

– Given:

– $N_{BO} = 300$ r.p.m. or $\omega_{BO} = 2\pi \times 300/60 = 31.42$ rad/s; $OB = 150$ mm = 0.15 m ; $BA = 600$ mm = 0.6 m

– We know that linear velocity of B with respect to O or velocity of B ,

$$v_{BO} = v_B = \omega_{BO} \times OB = 31.42 \times 0.15 = 4.713 \text{ m/s}$$

– Draw vector ob perpendicular to BO , to some suitable scale, to represent the velocity of B with respect to O or simply velocity of B i.e. v_{BO} or v_B , such that

$$\text{vector } ob = v_{BO} = v_B = 4.713 \text{ m/s}$$

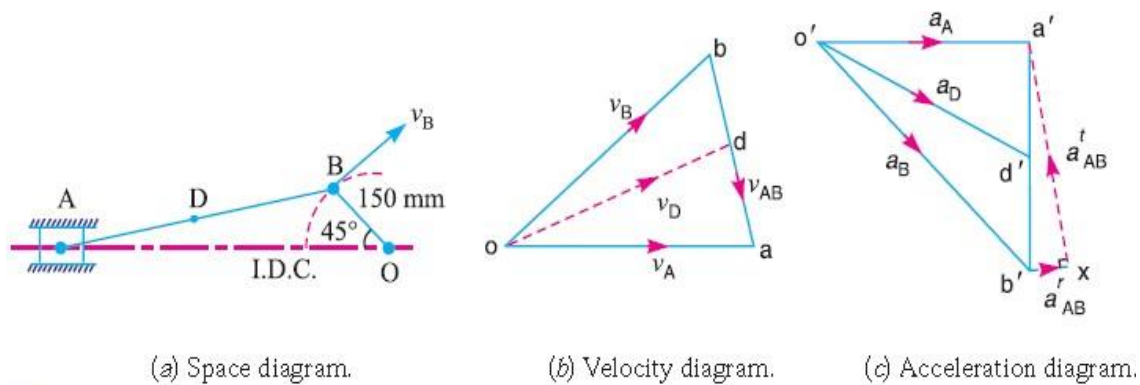

Fig. 3.19

- From point b, draw vector ba perpendicular to BA to represent the velocity of A with respect to B i.e. v_{AB} , and from point o draw vector oa parallel to the motion of A (which is along AO) to represent the velocity of A i.e. v_A . The vectors ba and oa intersect at a.

- By measurement we find the velocity A with respect to B,

$$v_{AB} = \text{vector } ba = 3.4 \text{ m/s}$$

$$v_A = \text{vector } oa = 4 \text{ m/s}$$

- In order to find the velocity of the midpoint D of the connecting rod AB, divide the vector ba at d in the same ratio as D divides AB, in the space diagram. In other words,

$$bd/ba = BD/BA$$

- By measurement, we find that

$$v_D = \text{vector } od = 4.1 \text{ m/s}$$

- We know that the radial component of the acceleration of B with respect to O or the acceleration of B,

$$a_{BO}^2 = a_B = \frac{v_{BO}^2}{OB} = \frac{(4.713)^2}{0.15} = 148.1 \text{ m/s}^2$$

- And the radial component of the acceleration of A with respect to B,

$$a_{AB}^r = \frac{v_{AB}^2}{BA} = \frac{(3.4)^2}{0.6} = 19.3 \text{ m/s}^2$$

$$\text{vector } o'b' = a_{BO}^r = a_B = 148.1 \text{ m/s}^2$$

- By measurement, we find that

$$a = \text{vector } o'd' = 117 \text{ m/s}^2$$

- We know that angular velocity of the connecting rod AB,

$$\omega_{AB} = \frac{v_{AB}}{BA} = \frac{3.4}{0.6} = 5.67 \text{ rad/s}^2$$

- From the acceleration diagram, we find that

$$a_{AB}^t = 103 \text{ m/s}^2$$

- We know that angular acceleration of the connecting rod AB,

$$\alpha_{AB} = \frac{a_{AB}^t}{BA} = \frac{103}{0.6} = 171.67 \text{ rad/s}^2$$

3.162 An engine mechanism is shown in Fig. 8.5. The crank $CB = 100$ mm and the connecting rod $BA = 300$ mm with centre of gravity G , 100 mm from B . In the position shown, the crankshaft has a speed of 75 rad/s and an angular acceleration of 1200 rad/s^2 . Find:

1. Velocity of G and angular velocity of AB , and
2. Acceleration of G and angular acceleration of AB .

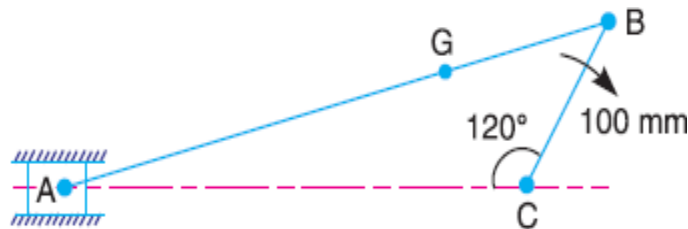

Fig.
3.20

– **Given**
:

- $\omega_{BC} = 75 \text{ rad/s}$; $\alpha_{BC} = 1200 \text{ rad/s}^2$, $CB = 100 \text{ mm} = 0.1 \text{ m}$; $BA = 300 \text{ mm} = 0.3 \text{ m}$
- We know that velocity of B with respect to C or velocity of B

$$v_{BC} = v_B = \omega_{BC} \times CB = 75 \times 0.1 = 7.5 \text{ m/s}$$

- Since the angular acceleration of the crankshaft, $\alpha_{BC} = 1200 \text{ rad/s}^2$, therefore tangential component of the acceleration of B with respect to C ,

$$a_{BC}^t = \alpha_{BC} \times CB = 1200 \times 0.1 = 120 \text{ m/s}^2$$

$$\text{vector } cb = v_{BC} = v_B = 7.5 \text{ m/s}$$

- By measurement, we find that velocity of G ,

$$v_G = \text{vector } cg = 6.8 \text{ m/s}$$

- From velocity diagram, we find that the velocity of A with respect to B ,

$$v_{AB} = \text{vector } ba = 4 \text{ m/s}$$



(a) Space diagram.

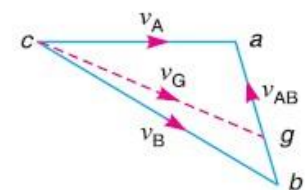

(b) Velocity diagram.

Fig. 3.21

- We know that angular velocity of AB ,

$$\omega_{AB} = \frac{v_{AB}}{BA} = \frac{4}{0.3} = 13.3 \text{ rad/s}$$

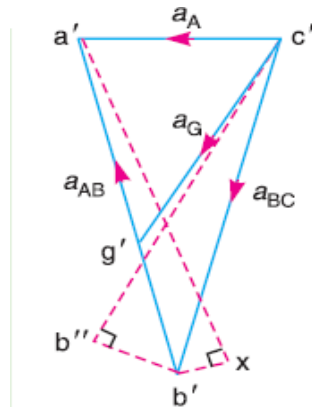

(c) Acceleration diagram.

Fig. 3.22

- We know that radial component of the acceleration of B with respect to C

$$a_{B/C}^r = \frac{v_{BC}^2}{CB} = \frac{(7.5)^2}{0.1} = 562.5 \text{ m/s}^2$$

- And radial component of the acceleration of A with respect to B,

$$a_{A/B}^r = \frac{v_A^2}{CB} = \frac{(4)^2}{0.3} = 53.3 \text{ m/s}^2$$

$$\text{vector } c'b'' = r_{BC} = 562.5 \text{ m/s}^2$$

$$\text{vector } b''b' = a_{BC}^t = 120 \text{ m/s}^2$$

$$\text{vector } b'x = a_{AB}^r = 53.3 \text{ m/s}^2$$

- By measurement we find that acceleration of G,

$$a_G = \text{vector } xa' = 414 \text{ m/s}^2$$

- From acceleration diagram, we find that tangential component of the acceleration of A with respect to B,

$$a_{AB}^t = \text{vector } xa' = 546 \text{ m/s}^2$$

- Angular acceleration of AB

$$\alpha_{AB} = \frac{a_{AB}^t}{BA} = \frac{546}{0.3} = 1820 \text{ rad/s}^2$$

3.163 In the mechanism shown in Fig. 8.7, the slider C is moving to the right with a velocity of 1 m/s and an acceleration of 2.5 m/s². The dimensions of various links are AB = 3 m inclined at 45° with the vertical and BC = 1.5 m inclined at 45° with the horizontal. Determine: 1. the magnitude of vertical and horizontal component of the acceleration of the point B, and 2. the angular acceleration of the links AB and BC.

- Given:

- $v_C = 1 \text{ m/s}$; $a_C = 2.5 \text{ m/s}^2$; $AB = 3 \text{ m}$; $BC = 1.5 \text{ m}$

- Here,

$$\text{vector } d = v_{CD} = v_C = 1 \text{ m/s}$$

- By measurement, we find that velocity of B with respect to A

$$v_{BA} = \text{vector } ab = 0.72 \text{ m/s}$$

- Velocity of B with respect to C

$$v_{BC} = \text{vector } cb = 0.72 \text{ m/s}$$

- We know that radial component of acceleration of B with respect to C,

$$a_{BC}^r = \frac{v_{BC}^2}{CB} = \frac{(0.72)^2}{1.5} = 0.346 \text{ m/s}^2$$

- And radial component of acceleration of B with respect to A,

$$a_{BA}^r = \frac{v_{BA}^2}{AB} = \frac{(0.72)^2}{3} = 0.173 \text{ m/s}^2$$

$$\text{vector } d'c' = a_{cd} = a_c = 2.5 \frac{\text{m}}{\text{s}^2}$$

$$\text{vector } 'x = a_{BC}^r = 0.346 \frac{\text{m}}{\text{s}^2}$$

$$\text{vector } 'y = a_{BA}^r = 0.173 \frac{\text{m}}{\text{s}^2}$$

- By measurement,

$$\text{vector } b'b'' = 1.13 \text{ m/s}^2$$

- By measurement from acceleration diagram, we find that tangential component of acceleration of the point B with respect to A

$$a_{BA}^t = \text{ector } yb' = 1.41 \text{ m/s}^2$$

- And tangential component of acceleration of the point B with respect to C,

$$a_{BC}^t = \text{vector } xb' = 1.94 \text{ m/s}^2$$

- we know that angular velocity of AB,

$$\alpha_{AB} = \frac{v_{BA}^t}{AB} = 0.47 \text{ rad/s}^2$$

- And angular acceleration of BC,

$$\alpha_{BC} = \frac{a_{BC}^t}{CB} = \frac{1.94}{1.5} \text{ rad/s}^2$$

References

1. Theory of Machines by S.S.Rattan, Tata McGraw Hill publication.
 2. Theory of Machines by R.S. Khurmi & J.K.Gupta,S.Chand publication.
-

4

Cams and Follower

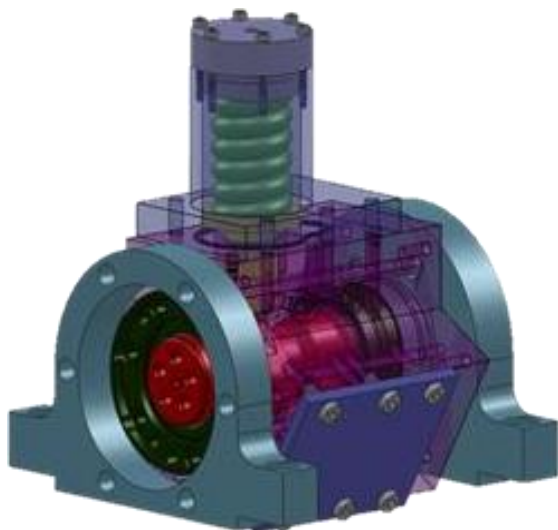
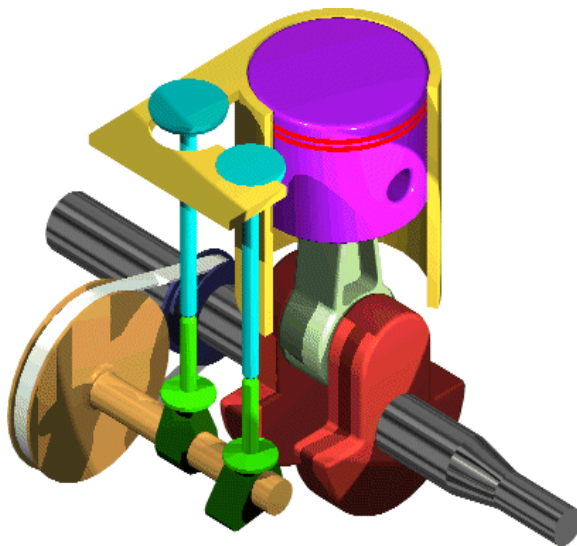

Course Contents

- 4.1 Introduction
- 4.2 Classification of follower
- 4.3 Classification of cams
- 4.4 Terms used in radial cam
- 4.5 Motion of follower
- 4.6 Displacement, velocity and acceleration diagrams when the follower moves with uniform velocity
- 4.7 Displacement, velocity and acceleration diagrams when the follower moves with SHM
- 4.8 Displacement, velocity and acceleration diagrams when the follower moves with uniform acceleration
- 4.9 Construction of a cam profile for a radial cam
- 4.10 Examples based on cam profile

4.1 Introduction

- A cam is a rotating machine element which gives reciprocating or oscillating motion to another element known as follower.
- The cam and the follower have a line contact and constitute a higher pair. The cams are usually rotated at uniform speed by a shaft, but the follower motion is pre-determined and will be according to the shape of the cam. The cam and follower is one of the simplest as well as one of the most important mechanisms found in modern machinery today.
- The cams are widely used for operating the inlet and exhaust valves of internal combustion engines, automatic attachment of machineries, paper cutting machines, spinning and weaving textile machineries, feed mechanism of automatic lathes etc.

4.2 Classification of Followers

The followers may be classified as discussed below :

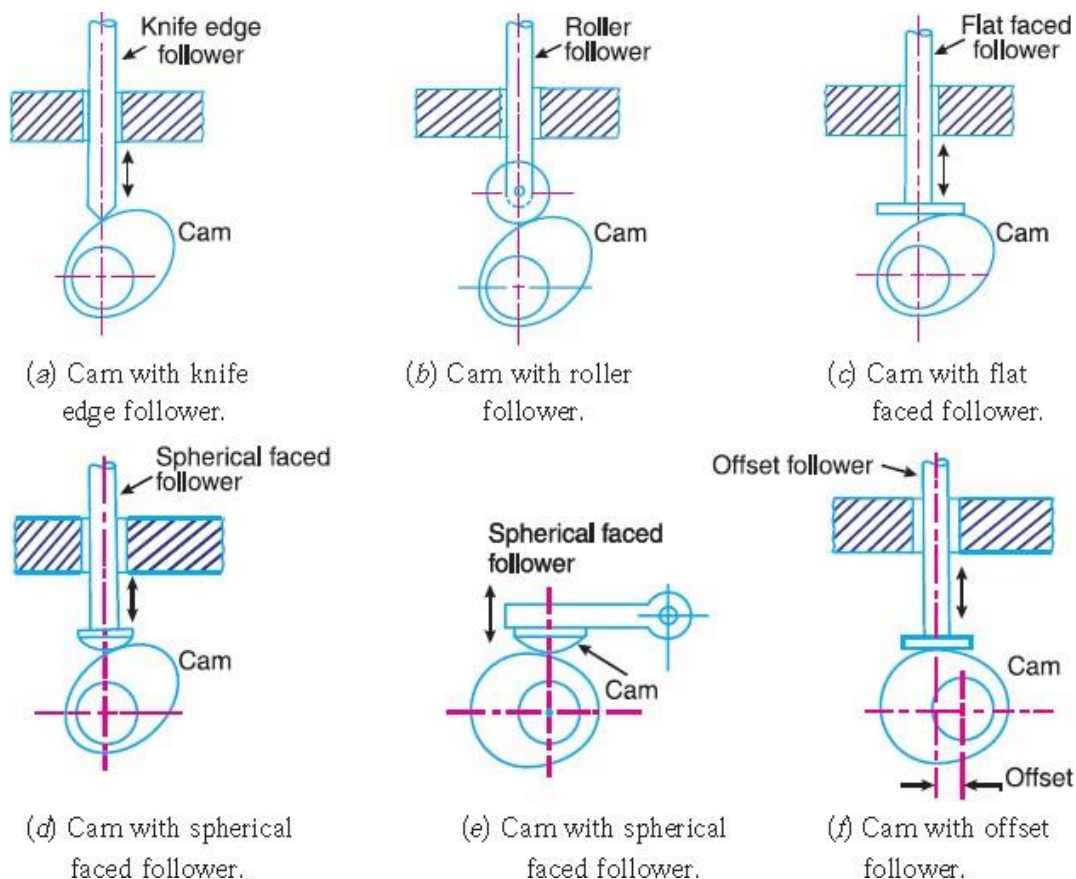

Fig. 4.1 classification of follower

According to surface in contact

a Knife edge follower

- When the contacting end of the follower has a sharp knife edge, it is called a knife edge follower, as shown in Fig. 7.1 (a).
- The sliding motion takes place between the contacting surfaces (i.e. the knife edge and the cam surface). It is seldom used in practice because the small area of contacting surface results in excessive wear. In knife edge followers, a considerable side thrust exists between the follower and the guide.

b Roller follower

- When the contacting end of the follower is a roller, it is called a roller follower, as shown in Fig. 7.1 (b). Since the rolling motion takes place between the contacting surfaces (i.e. the roller and the cam), therefore the rate of wear is greatly reduced.
- In roller followers also the side thrust exists between the follower and the guide. The roller followers are extensively used where more space is available such as in stationary gas and oil engines and aircraft engines.

c Flat faced or mushroom follower

- When the contacting end of the follower is a perfectly flat face, it is called a flat-faced follower, as shown in Fig. 7.1 (c). It may be noted that the side thrust between the follower and the guide is much reduced in case of flat faced followers.
- The only side thrust is due to friction between the contact surfaces of the follower and the cam. The relative motion between these surfaces is largely of sliding nature but wear may be reduced by off-setting the axis of the follower, as shown in Fig. 7.1 (f) so that when the cam rotates, the follower also rotates about its own axis.
- The flat faced followers are generally used where space is limited such as in cams which operate the valves of automobile engines.

d Spherical faced follower

- When the contacting end of the follower is of spherical shape, it is called a spherical faced follower, as shown in Fig. 7.1 (d). It may be noted that when a flat-faced follower is used in automobile engines, high surface stresses are produced. In order to minimize these stresses, the flat end of the follower is machined to a spherical shape.

According to the motion of follower

a Reciprocating or Translating Follower

- When the follower reciprocates in guides as the cam rotates uniformly, it is known as reciprocating or translating follower. The followers as shown in Fig. 7.1 (a) to (d) are all reciprocating or translating followers.

b Oscillating or Rotating Follower

- When the uniform rotary motion of the cam is converted into predetermined oscillatory motion of the follower, it is called oscillating or rotating follower. The follower, as shown in Fig 7.1 (e), is an oscillating or rotating follower.
-

According to the path of motion of the follower

a Radial Follower

- When the motion of the follower is along an axis passing through the centre of the cam, it is known as radial follower. The followers, as shown in Fig. 7.1 (a) to (e), are all radial followers.

b Off-set Follower

- When the motion of the follower is along an axis away from the axis of the cam centre, it is called off-set follower. The follower, as shown in Fig. 7.1 (f), is an off-set follower.

Classification of cams

a Radial or Disc cam

- In radial cams, the follower reciprocates or oscillates in a direction perpendicular to the cam axis. The cams as shown in Fig. 7.1 are all radial cams.

b Cylindrical cam

- In cylindrical cams, the follower reciprocates or oscillates in a direction parallel to the cam axis. The follower rides in a groove at its cylindrical surface. A cylindrical grooved cam with a reciprocating and an oscillating follower is shown in Fig. 7.2 (a) and (b) respectively.

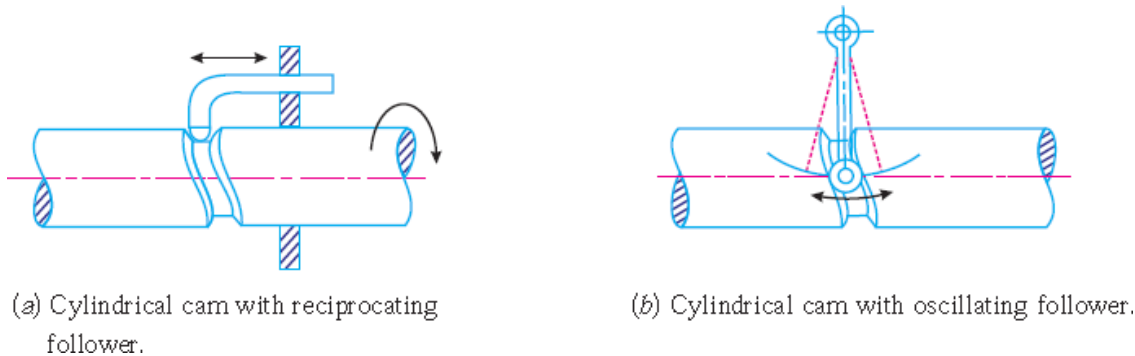

Fig. 4.2 cylindrical cam

4.3 Terms used in radial cams

a Base circle

- It is the smallest circle that can be drawn to the cam profile.

b Trace point

- It is a reference point on the follower and is used to generate the pitch curve. In case of knife edge follower, the knife edge represents the trace point and the pitch curve corresponds to the cam profile. In a roller follower, the centre of the roller represents the trace point.

c Pressure angle

- It is the angle between the direction of the follower motion and a normal to the pitch curve. This angle is very important in designing a cam profile. If the pressure angle is too large, a reciprocating follower

will jam in its bearings.

d Pitch point

- It is a point on the pitch curve having the maximum pressure angle.

e Pitch circle

- It is a circle drawn from the centre of the cam through the pitch points.

f Pitch curve

- It is the curve generated by the trace point as the follower moves relative to the cam. For a knife edge follower, the pitch curve and the cam profile are same whereas for a roller follower, they are separated by the radius of the roller.

g Prime circle

- It is the smallest circle that can be drawn from the centre of the cam and tangent to the pitch curve. For a knife edge and a flat face follower, the prime circle and the base circle are identical. For a roller follower, the prime circle is larger than the base circle by the radius of the roller.

h Lift or Stroke

- It is the maximum travel of the follower from its lowest position to the topmost position.

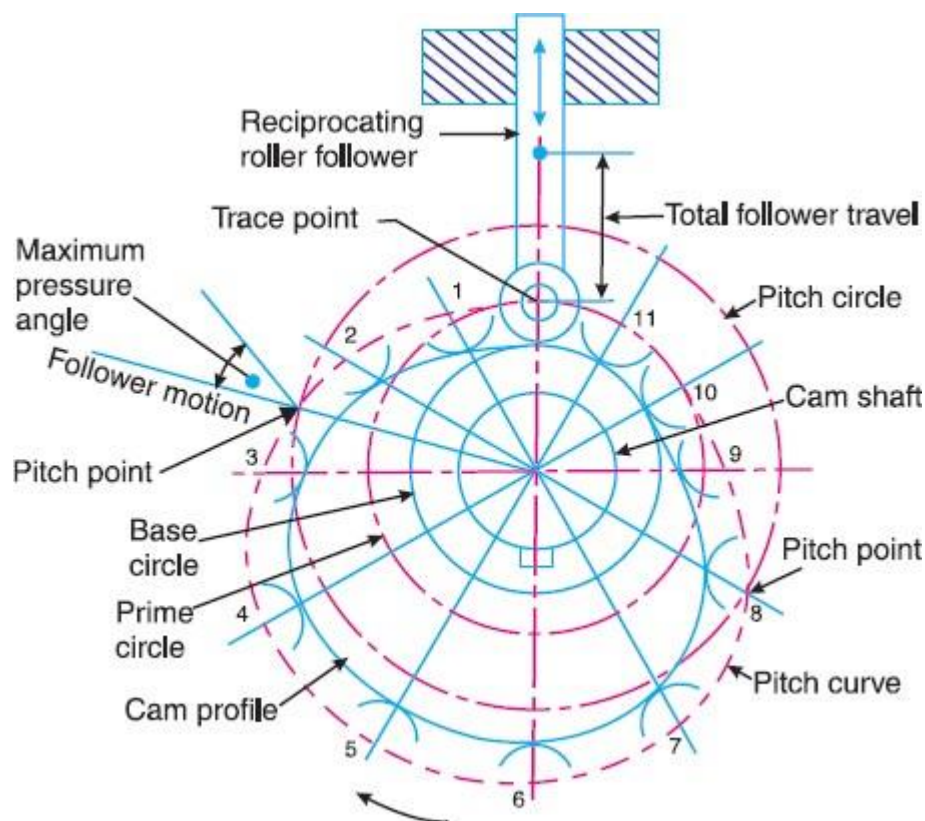

Fig. 4.3 terms used in radial cams

Motion of follower

The follower, during its travel, may have one of the following motions:

- Uniform velocity
- Simple harmonic motion
- Uniform acceleration and retardation
- Cycloidal motion

Displacement, Velocity and Acceleration Diagrams when the Follower Moves with Uniform Velocity

The displacement, velocity and acceleration diagrams when a knife-edged follower moves with uniform velocity are shown in Fig. 4.4 (a), (b) and (c) respectively.

The abscissa (base) represents the time (i.e. the number of seconds required for the cam to complete one revolution) or it may represent the angular displacement of the cam in degrees. The ordinate represents the displacement, or velocity or acceleration of the follower.

Since the follower moves with uniform velocity during its rise and return stroke, therefore the slope of the displacement curves must be constant. In other words, AB1 and C1D must be straight lines.

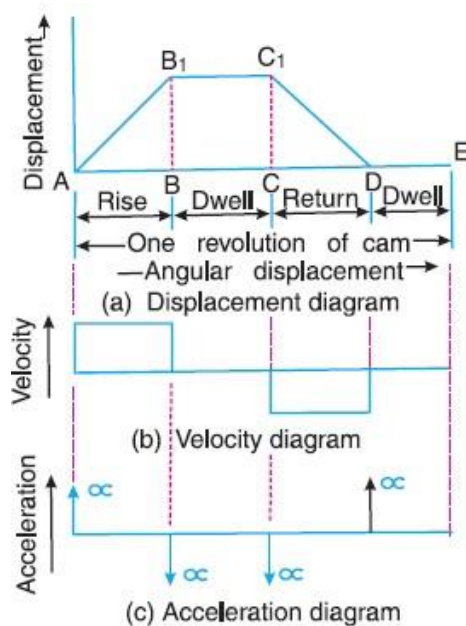

Fig. 4.4 displacement, velocity and acceleration diagrams

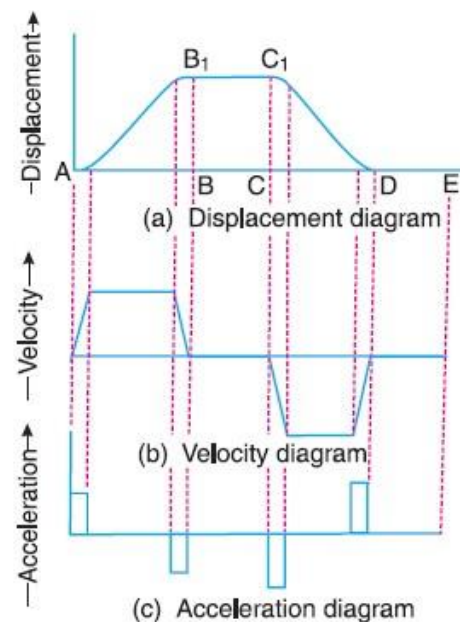

Fig. 4.5 modified displacement, velocity acceleration diagrams

A little consideration will show that the follower remains at rest during part of the cam rotation. The periods during which the follower remains at rest are

known as dwell periods, as shown by lines B1C1 and DE in Fig. 4.4 (a). From Fig. 4.4 (c), we see that the acceleration or retardation of the follower at the beginning and at the end of each stroke is infinite. This is due to the fact that the follower is required to start from rest and has to gain a velocity within no time. This is only possible if the acceleration or retardation at the beginning and at the end of each stroke is infinite. These conditions are however, impracticable.

In order to have the acceleration and retardation within the finite limits, it is necessary to modify the conditions which govern the motion of the follower. This may be done by rounding off the sharp corners of the displacement diagram at the beginning and at the end of each stroke, as shown in Fig. 4.5 (a). By doing so, the velocity of the follower increases gradually to its maximum value at the beginning of each stroke and decreases gradually to zero at the end of each stroke as shown in Fig. 4.5 (b).

The modified displacement, velocity and acceleration diagrams are shown in Fig.4.5. The round corners of the displacement diagram are usually parabolic curves because the parabolic motion results in a very low acceleration of the follower for a given stroke and cam speed.

Displacement, Velocity and Acceleration Diagrams when the Follower Moves with Simple Harmonic Motion

The displacement, velocity and acceleration diagrams when the follower moves with simple harmonic motion are shown in Fig. 4.6 (a), (b) and (c) respectively. The displacement diagram is drawn as follows:

- a Draw a semi-circle on the follower stroke as diameter.
- b Divide the semi-circle into any number of even equal parts (say eight).
- c Divide the angular displacements of the cam during out stroke and return stroke into the same number of equal parts.
- d The displacement diagram is obtained by projecting the points as shown in Fig. 7.6 (a).

The velocity and acceleration diagrams are shown in Fig. 4.6 (b) and (c) respectively.

Since the follower moves with a simple harmonic motion, therefore velocity diagram consists of a sine curve and the acceleration diagram is a cosine curve.

We see from Fig. 4.6 (b) that the velocity of the follower is zero at the beginning and at the end of its stroke and increases gradually to a maximum at mid-stroke. On the other hand, the acceleration of the follower is maximum at the beginning and at the ends of the stroke and diminishes to zero at mid-stroke.

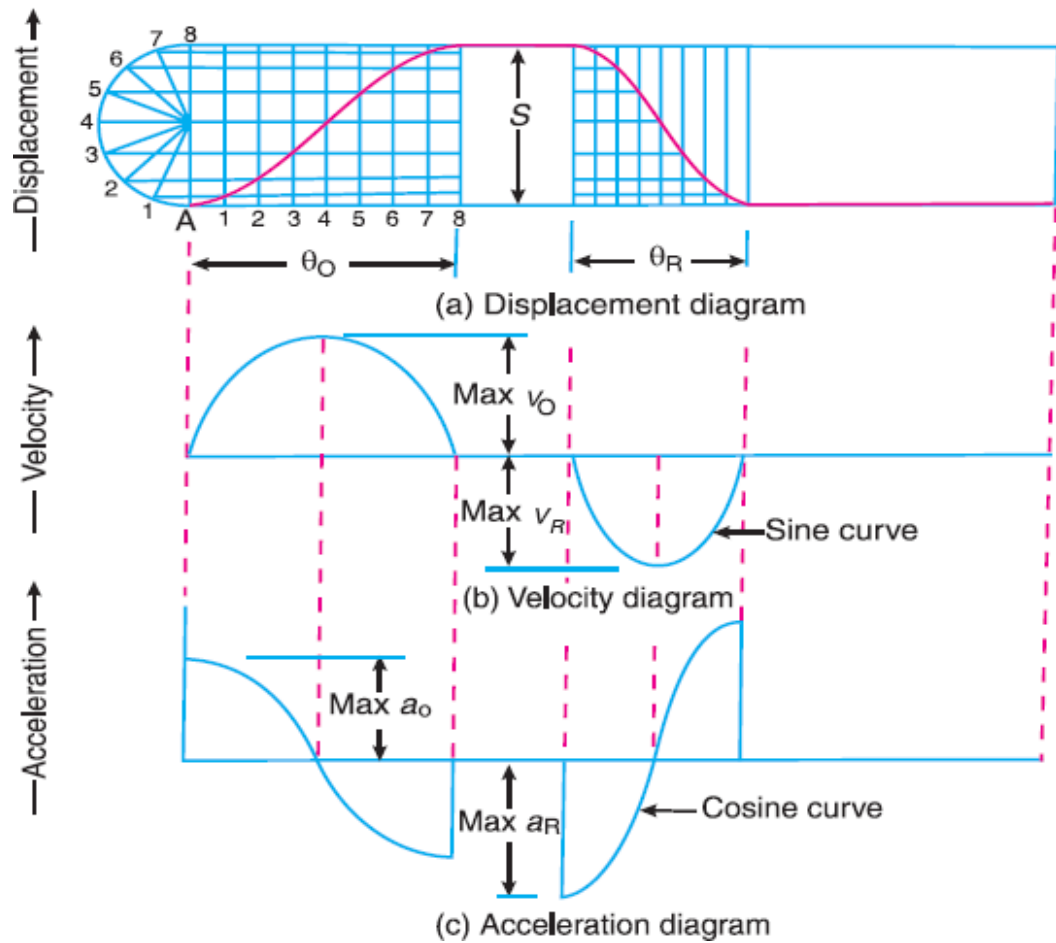

Fig. 7.6 acceleration diagram

4.3.1 L

S = Stroke of the follower

t

θ_O and θ_R = Angular displacement of the cam during out stroke and return stroke of the follower respectively

ω = angular velocity of cam

Time required for the outstroke of the follower in second

$$t_0 = \frac{\theta_O}{\omega}$$

Consider a point P moving at uniform speed ω_p radians per sec round the circumference of a circle with the stroke S as diameter, as shown in Fig. 7.7 the point (which is the projection of a point P on the diameter) executes a simple harmonic motion as the point P rotates. The motion of the follower is similar to that of point P'.

Peripheral speed of the point P'

$$v_p = \frac{\pi \times s}{2} \times \frac{1}{t_0} = \frac{\pi \times s}{2} \times \frac{\omega}{\theta_O}$$

and maximum velocity of the follower on the outstroke,

$$v_0 = v_p = \frac{\pi \times s}{2} \times \frac{\omega}{\theta_O} = \frac{\pi \times \omega \times s}{2 \theta_O}$$

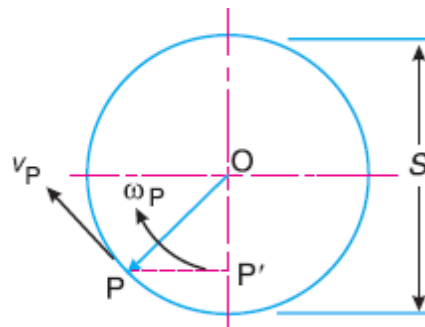

Fig. 7.7 motion of a point

We know that the centripetal acceleration of the point P

$$a_p = \frac{v_p^2}{op} = \left(\frac{\omega \times s}{2 \theta_0} \right)^2 \times \frac{2}{s} = \frac{\pi^2 \times \omega^2 \times s}{2 \times (\theta_0)^2}$$

Maximum acceleration of the follower on the outstroke,

$$a_0 = a_p = \frac{\pi^2 \times \omega^2 \times s}{2 \times (\theta_0)^2}$$

Similarly, maximum velocity of the follower on the return stroke,

$$v_R = \frac{\pi \times \omega \times S}{2 \theta_R}$$

and maximum acceleration of the follower on the return stroke

$$a_R = \frac{\pi^2 \omega^2 S}{2 (\theta_R)^2}$$

Displacement, Velocity and Acceleration Diagrams when the Follower Moves with Uniform Acceleration and Retardation

The displacement, velocity and acceleration diagrams when the follower moves with uniform acceleration and retardation are shown in Fig. 4.8 (a), (b) and (c) respectively. We see that the displacement diagram consists of a parabolic curve and may be drawn as discussed below:

Divide the angular displacement of the cam during outstroke (Θ) into any even number of equal parts and draw vertical lines through these points as shown in fig. 4.8 (a)

Divide the stroke of the follower (S) into the same number of equal even parts.

Join Aa to intersect the vertical line through point 1 at B. Similarly, obtain the other points C, D etc. as shown in Fig. 20.8 (a). Now join these points to obtain the parabolic curve for the out stroke of the follower.

In the similar way as discussed above, the displacement diagram for the follower during return stroke may be drawn.

We know that time required for the follower during outstroke,

$$t_o = \frac{\theta_o}{\omega}$$

and time required for the follower during return stroke,

$$t_R = \frac{\theta_R}{\omega}$$

Mean velocity of the follower during outstroke

$$v_o = \frac{S}{t_o}$$

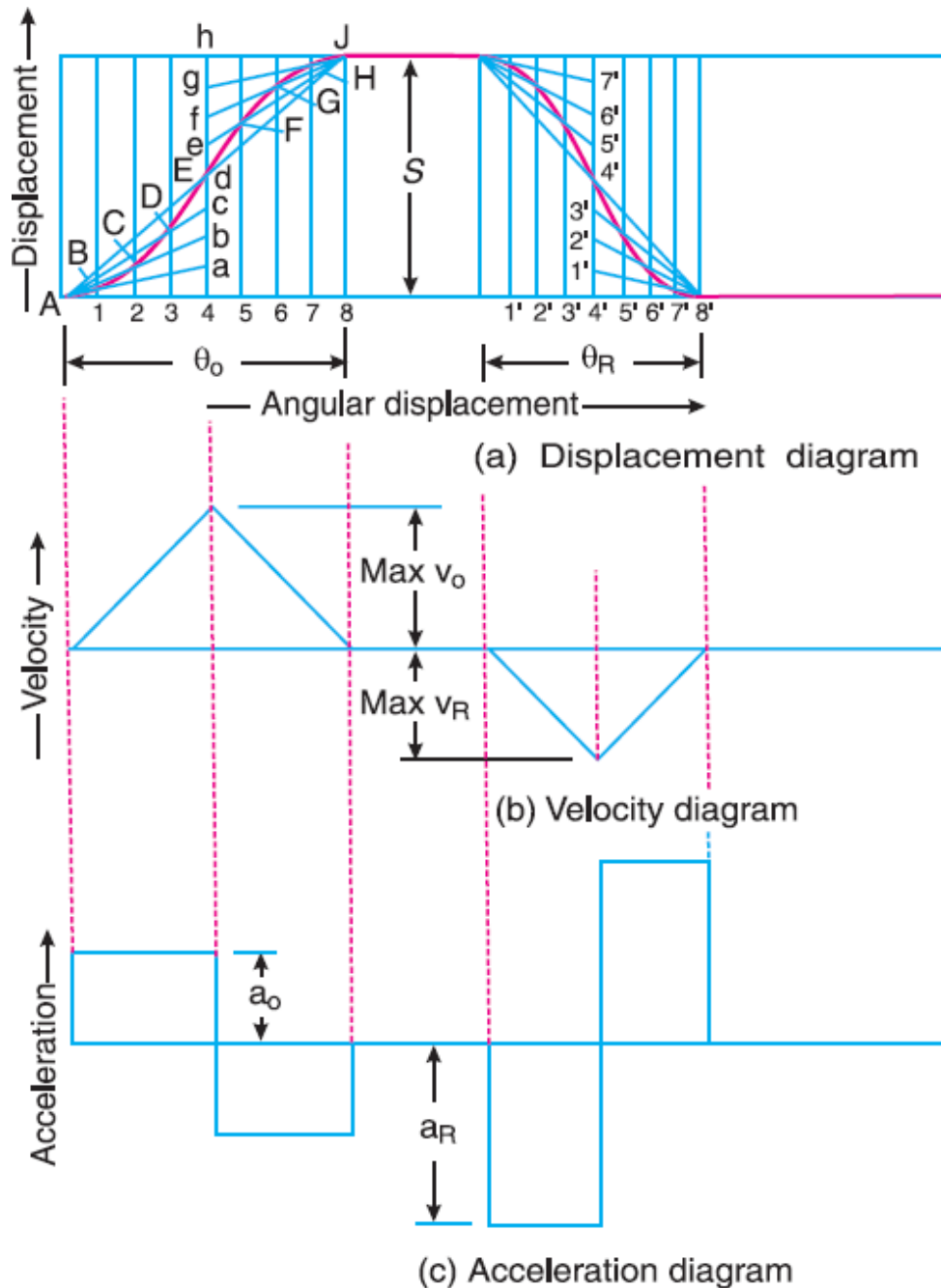

Fig. 4.8 Displacement, Velocity and Acceleration Diagrams when the Follower Moves with Uniform Acceleration and Retardation

Since the maximum velocity of follower is equal to twice the mean velocity, therefore maximum velocity of the follower during outstroke,

$$v_0 = \frac{2S}{t_0} = \frac{2\omega S}{\theta_0}$$

Similarly, maximum velocity of the follower during return stroke,

$$v_R = \frac{2\omega S}{\theta_R}$$

Maximum acceleration of the follower during outstroke,

$$a_0 = \frac{v_0}{t_0/2} = \frac{2 \times 2\omega S}{t_0 \theta_0} = \frac{4\omega^2 S}{(\theta_0)^2}$$

Similarly, maximum acceleration of the follower during return stroke,

$$a_R = \frac{4\omega^2 S}{(\theta)^2}$$

Displacement, Velocity and Acceleration Diagrams when the Follower Moves with cycloidal Motion

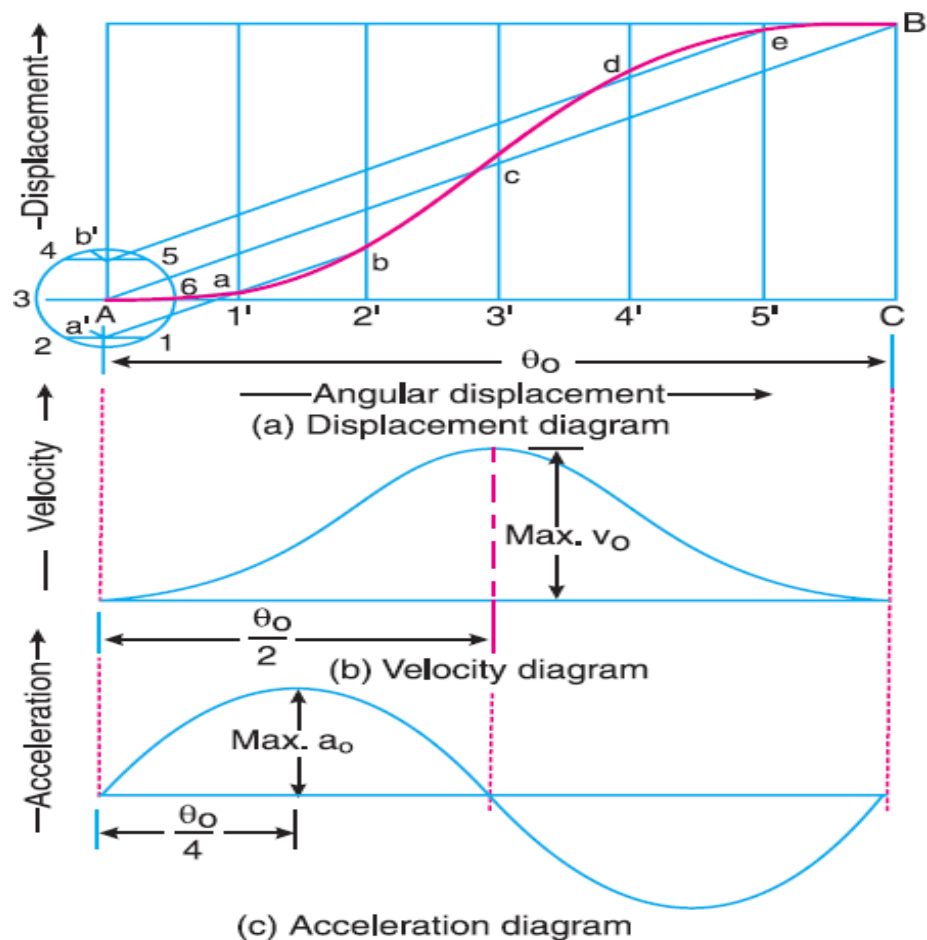

- The displacement, velocity and acceleration diagrams when the follower moves with cycloidal motion are shown in Fig. (a), (b) and (c) respectively. We know that cycloid is a curve traced by a point on a circle when the circle rolls without slipping on a straight line.

- We know that displacement of the follower after time t seconds,

$$x = S \left[\frac{\theta}{\theta_0} - \frac{1}{2\pi} \sin\left(\frac{2\pi\theta}{\theta_0}\right) \right]$$

- Velocity of the follower after time t seconds,

$$\begin{aligned} \frac{dx}{dt} &= S \left[\frac{1}{\theta_0} \times \frac{d\theta}{dt} - \frac{2\pi\theta}{\theta_0} \cos\left(\frac{2\pi\theta}{\theta_0}\right) \frac{d\theta}{dt} \right] \\ &= \frac{S}{\theta_0} \times \frac{d\theta}{dt} \left[1 - \cos\left(\frac{2\pi\theta}{\theta_0}\right) \right] \\ &= \frac{\omega S}{\theta_0} \left[1 - \cos\left(\frac{2\pi\theta}{\theta_0}\right) \right] \end{aligned}$$

- The velocity is maximum, when

$$\cos\left(\frac{2\pi\theta}{\theta_0}\right) = -1$$

$$\frac{2\pi\theta}{\theta_0} = \pi$$

$$= \frac{\theta_0}{2}$$

- Similarly, maximum velocity of the follower during return stroke,

$$v_R = \frac{2\omega S}{\theta_R}$$

- Now, acceleration of the follower after time t sec,

$$\frac{d^2x}{dt^2} = \frac{\omega S}{\theta_0} \left[\frac{2\pi\theta}{\theta_0} \sin\left(\frac{2\pi\theta}{\theta_0}\right) \frac{d\theta}{dt} \right]$$

$$= \frac{2\pi\omega^2 S}{(\theta_0)^2} \sin\left(\frac{2\pi\theta}{\theta_0}\right)$$

- The acceleration is maximum, when

$$\sin\left(\frac{2\pi\theta}{\theta_0}\right) = 1$$

$$= \frac{\theta_0}{4}$$

$$a_0 = \frac{2\pi\omega^2 S}{(\theta_0)^2}$$

$$a_R = \frac{2 \pi \omega^2 S (\theta)}{(\theta)^2}$$

Construction of cam profile for a Radial cam

In order to draw the cam profile for a radial cam, first of all the displacement diagram for the given motion of the follower is drawn. Then by constructing the follower in its proper position at each angular position, the profile of the working surface of the cam is drawn.

In constructing the cam profile, the principle of kinematic inversion is used, i.e. the cam is imagined to be stationary and the follower is allowed to rotate in the opposite direction to the cam rotation.

Examples based on cam profile

Draw the profile of a cam operating a knife-edge follower having a lift of 30 mm. the cam raises the follower with SHM for 150° of the rotation followed by a period of dwell for 60°. The follower descends for the next 100° rotation of the cam with uniform velocity, again followed by a dwell period. The cam rotates at a uniform velocity of 120 rpm and has a least radius of 20 mm. what will be the maximum velocity and acceleration of the follower during the lift and the return?

- $S = 30 \text{ mm} ; \theta_a = 150^\circ ; N = 120 \text{ rpm} ;$
- $\delta_1 = 60^\circ ; r_c = 20 \text{ mm} ; \delta_2 = 50^\circ$
- **During ascent:**

$$\omega = \frac{2 \pi N}{60} = \frac{2 \pi \times 120}{60} = 12.57 \text{ rad/s}$$

$$v_{max} = \frac{\pi \times \omega \times S}{2 \theta_0} = \frac{\pi \times 12.57 \times 30}{2 \times 150 \times \frac{\pi}{180}} = 226.3$$

$$a_{max} = \frac{\pi^2 \times \omega^2 \times S}{2 \times (\theta^0)^2} = \frac{\pi^2 \times 12.57^2 \times 30}{2 \times (150 \times \frac{\pi}{180})^2} = 7.413 \text{ m/s}^2$$

- **During descent:**

$$v_{max} = \frac{\omega S}{\theta_d}$$

$$v_{max} = \frac{12.57 \times 30}{100 \times \frac{\pi}{180}} = 216 \text{ mm/s}$$

$$f_{max} = 0$$

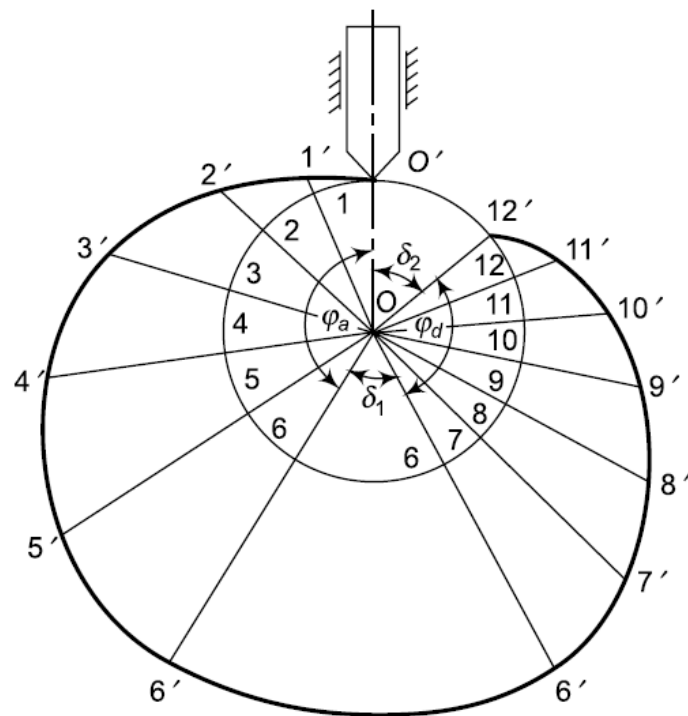
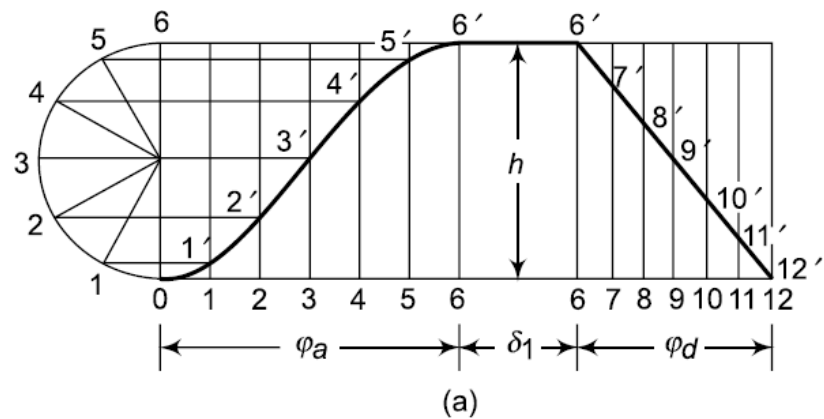

Fig. 4.10

A cam with a minimum radius of 25 mm is to be designed for a knife-edge follower with the following data:

To raise the follower through 35 mm during 60° rotation of the cam

Dwell for next 40° of the cam rotation

Descending of the follower during the next 90° of the cam rotation

Dwell during the rest of the cam rotation

Draw the profile of cam if the ascending and descending of the cam with simple harmonic motion and the line of stroke of the follower is offset 10 mm from the axis of the cam shaft.

What is the maximum velocity and acceleration of the follower during the ascent and the descent if the cam rotates at 150 rpm?

- $S = 35 \text{ mm}$; $\phi_a = 60^\circ$; $N = 150 \text{ rpm}$;
- $\delta_1 = 40^\circ$; $r_c = 25 \text{ mm}$; $\phi_d = 90^\circ$; $x = 10 \text{ mm}$

- **During ascent:**

$$\omega = \frac{2\pi N}{60} = \frac{2\pi \times 150}{60} = 5\pi \frac{\text{rad}}{\text{s}}$$

$$v_{max} = \frac{\pi \times \omega \times s}{2\theta_0} = \frac{\pi \times 5\pi \times 35}{150 \times \frac{\pi}{180}} = 827.7 \text{ mm/s}$$

$$a_{max} = \frac{\pi^2 \times \omega^2 \times s}{2 \times (\theta_0)^2} = \frac{\pi^2 \times 5\pi^2 \times 35}{2 \times (150 \times \frac{\pi}{180})^2} = 38.882 \text{ m/s}^2$$

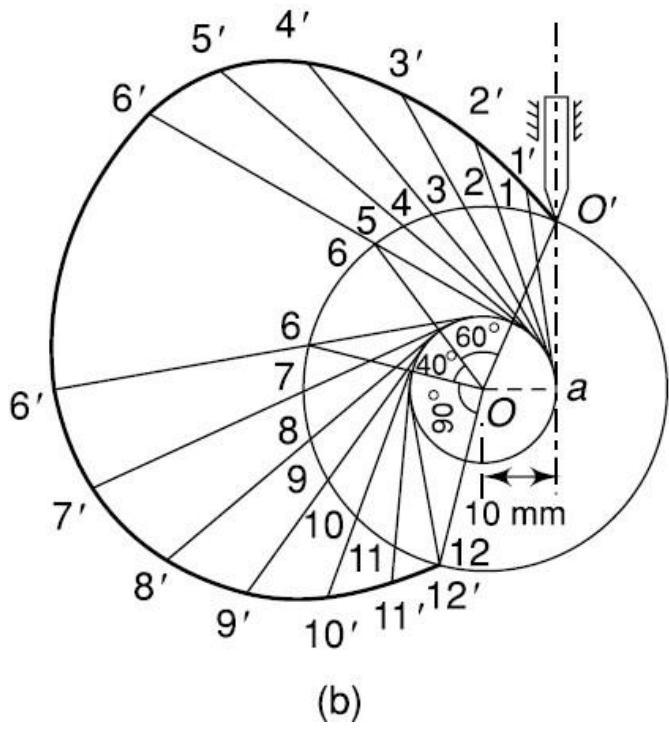
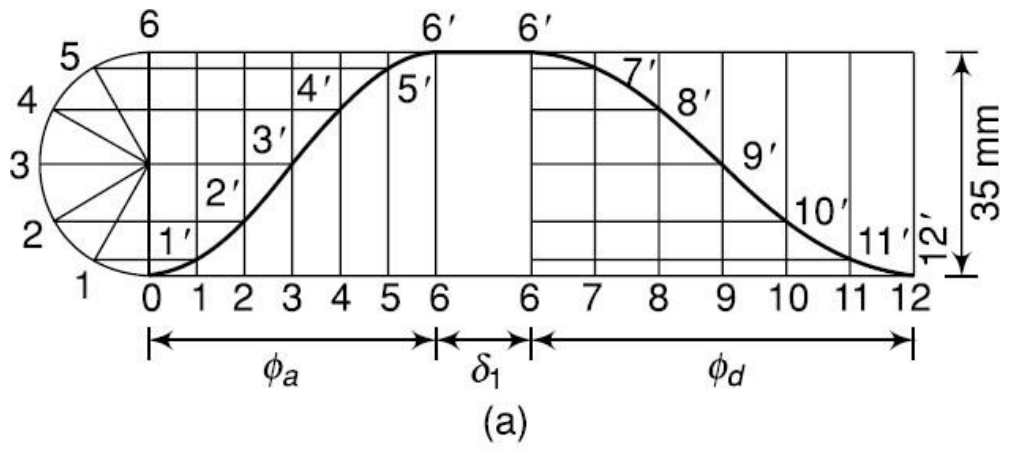

Fig. 7.11

- **During descent:**

$$v_{max} = \frac{\pi \times \omega \times s}{\theta_0} = \frac{\pi \times 5 \times 35}{90 \times \frac{\pi}{180}} = 549.80 \text{ mm/s}$$

$$a_{max} = \frac{\pi^2 \times \omega^2 \times s}{2 \times (\theta^0)^2} = \frac{\pi^2 \times 5\pi^2 \times 35}{2 \times (90 \times \frac{\pi}{180})^2} = 17.272 \text{ m/s}^2$$

A cam is to give the following motion to the knife-edged follower:

To raise the follower through 30 mm with uniform acceleration and deceleration during 120° rotation of the cam

Dwell for the next 30° of the cam rotation

To lower the follower with simple harmonic motion during the next 90° rotation of the cam

Dwell for the rest of the cam rotation

The cam has minimum radius of 30 mm and rotates counter-clockwise at a uniform speed of 800 rpm. Draw the profile of the cam if the line of stroke of the follower passes through the axis of the cam shaft.

– $S = 30 \text{ mm}$; $\phi_a = 120^\circ$; $N = 800 \text{ rpm}$;

– $\delta_1 = 30^\circ$; $r_c = 30 \text{ mm}$; $\phi_d = 90^\circ$;

– **During ascent:**

$$\omega = \frac{2\pi N}{60} = \frac{2\pi \times 840}{60} = 88 \frac{\text{rad}}{\text{s}}$$

$$v_{max} = \frac{2 \times 88 \times 0.03}{120 \times \frac{\pi}{180}} = 2.52 \text{ m/s}$$

$$a_0 = \frac{4\omega^2 S}{(\)^2} = \frac{4 \times 88^2 \times 0.03}{(120 \times \frac{\pi}{180})^2} = 211.9 \text{ m/s}^2$$

– **During descent:**

$$v_{max} = \frac{\pi \times \omega \times s}{\theta_0} = \frac{\pi \times 88 \times 0.03}{2 \times 90 \times \frac{\pi}{180}} = 2.64 \text{ mm/s}$$

$$a_{max} = \frac{\pi^2 \times \omega^2 \times s}{2 \times (\theta_0)^2} = \frac{\pi^2 \times 88^2 \times 0.03}{2 \times (90 \times \frac{\pi}{180})^2} = 467.6 \text{ m/s}^2$$

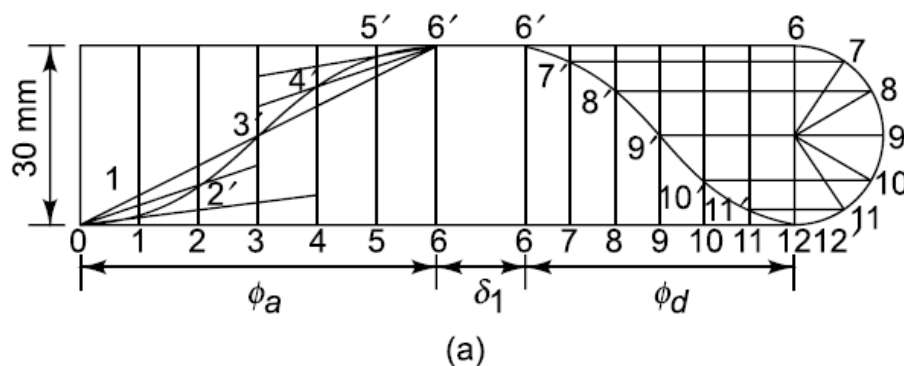

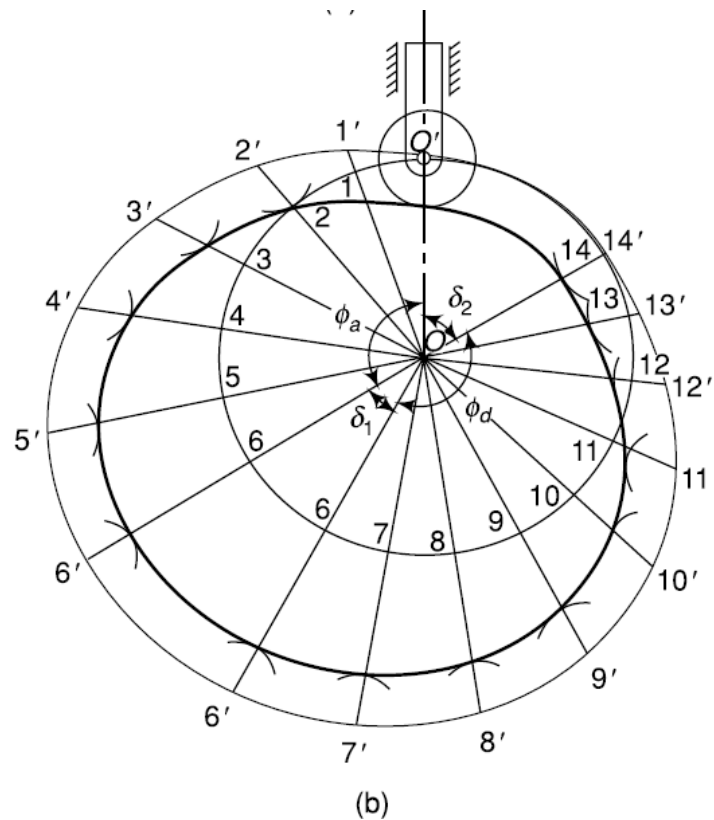

Fig. 7.13

$$v_{max} = \frac{2 \times s \times \omega}{\phi_d}$$

$$v_{max} = \frac{2 \times 30 \times \frac{2 \times \pi \times 150}{60}}{150 \times \frac{\pi}{180}} = 360 \text{ m/s}$$

$$f_{max} = \frac{4 \times S \times \omega^2}{(\phi_d)^2}$$

$$f_{max} = \frac{4 \times 30 \times \left(\frac{2 \times \pi \times 150}{60}\right)^2}{\left(150 \times \frac{\pi}{180}\right)^2} = 4320 \text{ mm/s}^2$$

The following data relate to a cam profile in which the follower moves with uniform acceleration and deceleration during ascent and descent.

Minimum radius of cam = 25 mm

Roller diameter = 7.5 mm

Lift = 28 mm

Offset of follower axis = 12 mm towards right

Angle of ascent = 60°

Angle of descent = 90°

Angle of dwell between ascent and descent = 45°

Speed of cam = 200 rpm

Draw the profile of the cam and determine the maximum velocity and the uniform acceleration of the follower during the outstroke and the return stroke.

- $S = 28 \text{ mm} ; \phi_a = 60^\circ ; N = 200 \text{ rpm} ; \phi_d = 90^\circ$
- $\delta_1 = 45^\circ ; r_c = 25 \text{ mm} ; \delta_2 = 165^\circ ; r_r = 7.5 \text{ mm} ; x = 12 \text{ mm}$

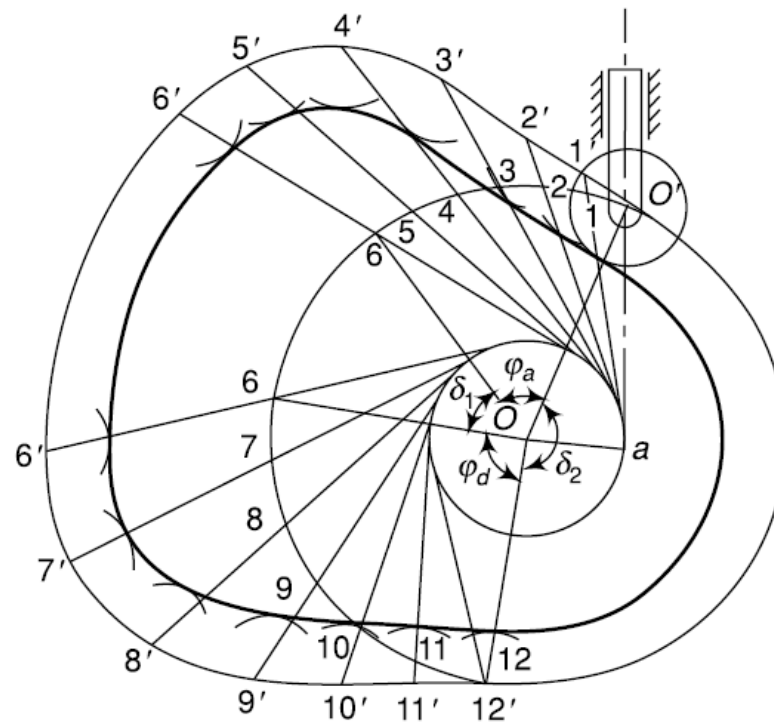
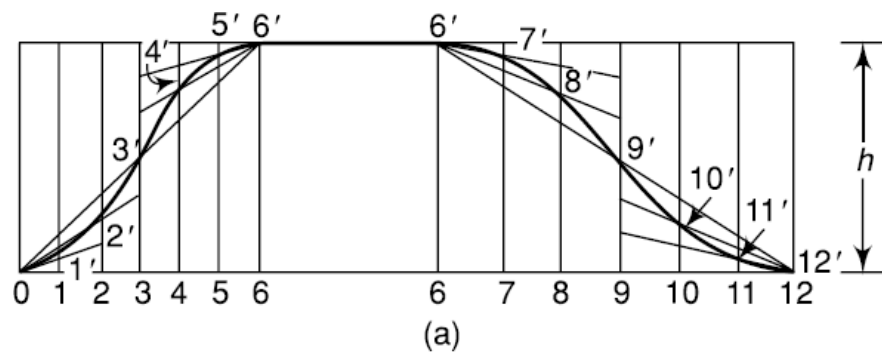

(b)

Fig. 7.14

- **During outstroke:**

$$v_{max} = \frac{2 \times s \times \omega}{\phi_d}$$

$$v_{max} = \frac{2 \times 28 \times 20.94}{60 \times \frac{\pi}{180}} = 1.12 \text{ m/s}$$

$$f_{max} = \frac{4 \times S \times \omega^2}{(\phi_d)^2}$$

$$f_{max} = \frac{4 \times 30 \times (20.94)^2}{\left(60 \times \frac{\pi}{180}\right)^2} = 44800 \text{ mm/s}^2$$

- **During Return stroke:**

$$v_{max} = \frac{2 \times s \times \omega}{\varphi_d}$$

$$v_{max} = \frac{2 \times 28 \times 20.94}{90 \times \frac{\pi}{180}} = 0.747 \text{ m/s}$$

$$f_{max} = \frac{4 \times S \times \omega^2}{(\varphi_d)^2}$$

$$f_{max} = \frac{4 \times 30 \times (20.94)^2}{\left(90 \times \frac{\pi}{180}\right)^2} = 19900 \text{ mm/s}^2$$

A flat-faced mushroom follower is operated by a uniform rotating cam. The follower is raised through a distance of 25 mm in 120° rotation of the cam, remains at rest for next 30° and is lowered during further 120° rotation of the cam. The raising of the follower takes place with cycloidal motion and the lowering with uniform acceleration and deceleration. However, the uniform acceleration is 2/3 of the uniform deceleration. The least radius of the cam is 25 mm which rotates at 300 rpm.

Draw the cam profile and determine the values of the maximum velocity and maximum acceleration during rising and maximum velocity and uniform acceleration and deceleration during lowering of the follower.

- $S = 30 \text{ mm} ; \varphi_a = 60^\circ ; N = 200 \text{ rpm} ; \varphi_d = 90^\circ$
- $\delta_1 = 45^\circ ; r_c = 25 \text{ mm} ; \delta_2 = 165^\circ ; r_f = 7.5 \text{ mm} ; x = 12 \text{ mm}$
-

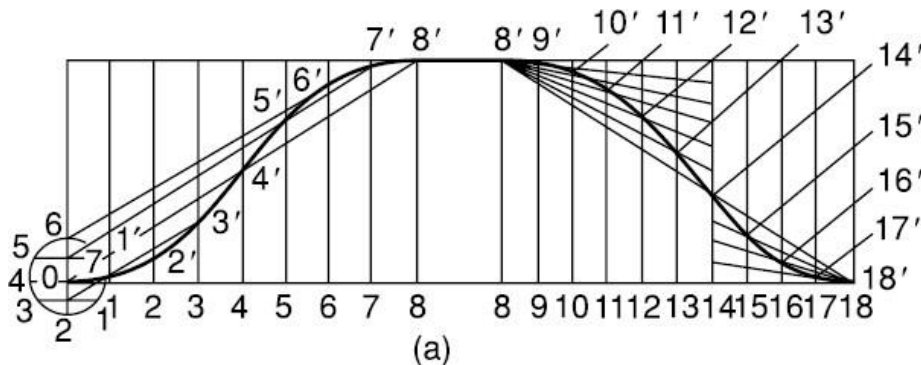

Highest position = 60°

Angle of oscillation of

Follower = 28°

Draw the profile of the cam if the ascent and descent both take place with SHM.

- $S = 19.5 \text{ mm}$: $\phi_a = 75^\circ$; $\phi_d = 105^\circ$
- $\delta_1 = 60^\circ$; $r_c = 22 \text{ mm}$: $\delta_2 = 120^\circ$; $r_r = 7.5 \text{ mm}$;

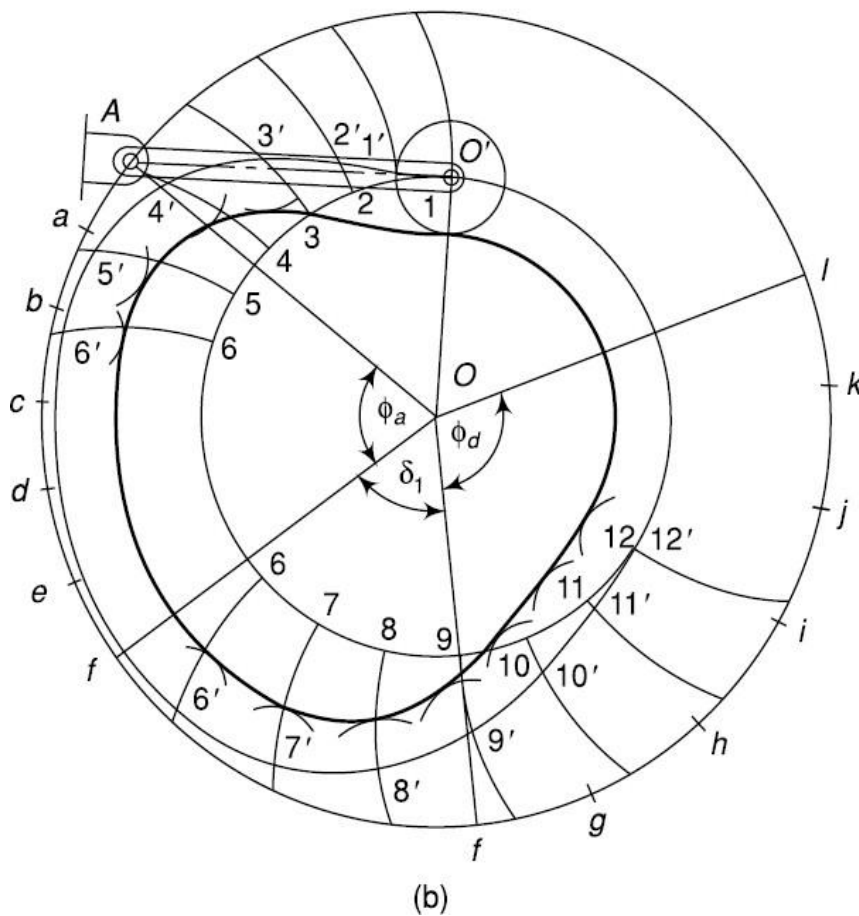
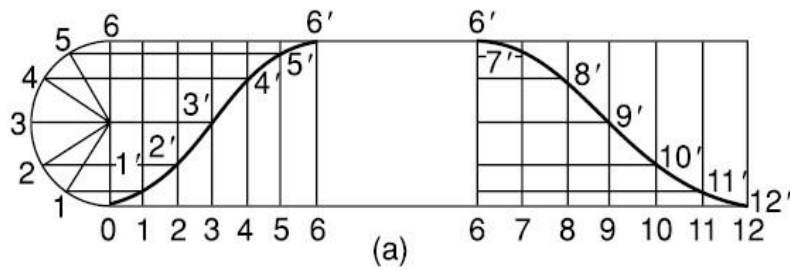

Fig. 4.16

References

1. Theory of Machines by S.S.Rattan, Tata McGraw Hill
2. Theory of Machines by R.S. Khurmi & J.K.Gupta,S.Chand

5

GEARS



Course Contents

- 5.1 Introduction
- 5.2 Advantages and Disadvantages of Gear Drive
- 5.3 Classification of Gears
- 5.4 Terms Used in Gears
- 5.5 Law of Gearing
- 5.6 Standard Tooth Profiles or Systems
- 5.7 Length of Path of Contact & Length of Arc of Contact
- 5.8 Interference in Involute Gears
- 5.9 Minimum Number of Teeth on the Pinion in Order to Avoid Interference
- 5.10 Minimum Number of Teeth on the Wheel in Order to Avoid Interference
- 5.11 Minimum Number of Teeth on a Pinion for Involute Rack in Order to Avoid Interference
- 5.12 Comparison of Cycloidal and Involute tooth forms
- 5.13 Helical and spiral gears
- 5.14 Examples

5.1 Introduction

- If power transmitted between two shafts is small, motion between them may be obtained by using two plain cylinders or discs 1 and 2 as shown in fig.
- If there is no slip of one surface relative to the other, a definite motion of 1 can be transmitted to 2 and vice-versa. Such wheels are termed as “**friction wheels**”. However, as the power transmitted increases, slip occurs between the discs and the motion no longer remains definite.
- Assuming no slipping of the two surfaces, the following kinematic relationship exists for their linear velocity:
- To transmit a definite motion of one disc to the other or to prevent slip between the surfaces, projection and recesses on the two discs can be made which can mesh with each other. This leads to formation of teeth on the discs and the motion between the surfaces changes from rolling to sliding. The discs with the teeth are known as **gears** or **gear wheels**.
- It is to be noted that if the disc 1 rotates in the clockwise direction, 2 rotates in the counter clockwise direction and vice-versa.

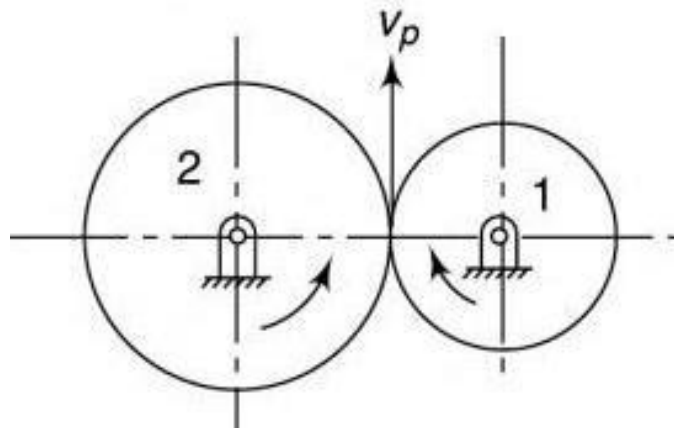

Fig. 5.1

5.2 Advantages and Disadvantages of Gear Drive

Advantages

1. It transmits exact velocity ratio.
2. It may be used to transmit large power.
3. It has high efficiency.
4. It has reliable service.
5. It has compact layout.

Disadvantages

1. The manufacture of gears required special tools and equipment.
2. The error in cutting teeth may cause vibrations and noise during operation.
3. They are costly.

5.3 Classification of Gears

5.3.1. According to the position of axes of the shafts

- A. The axes of the two shafts between which the motion is to be transmitted, may be Parallel shaft,
- B. Intersecting (Non parallel) shaft
- C. Non-intersecting and non-parallel shaft.

A. Parallel shaft

- **Spur gear**

- The two parallel and co-planar shafts connected by the gears are called *spur gears*. These gears have teeth parallel to the axis of the wheel.
- They have straight teeth parallel to the axes and thus are not subjected to axial thrust due to tooth load.
- At the time of engagement of the two gears, the contact extends across the entire width on a line parallel to the axis of rotation. This results in sudden application of the load, high impact stresses and excessive noise at high speeds.
- If the gears have external teeth on the outer surface of the cylinders, the shaft rotate in the opposite direction.
- In an internal spur gear, teeth are formed on the inner surface of an annulus ring. An internal gear can mesh with an external pinion (smaller gear) only and the two shafts rotate in the same direction.

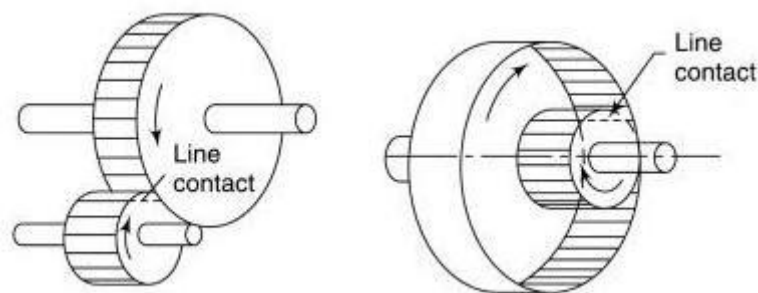

Fig.5.3 (a) Spur Gear

- *Spur rack and pinion*

- Spur rack is a special case of a spur gear where it is made of infinite diameter so that the pitch surface is plane.
- The spur rack and pinion combination converts rotary motion into translator motion, or vice-versa.
- It is used in a lathe in which the rack transmits motion to the saddle.

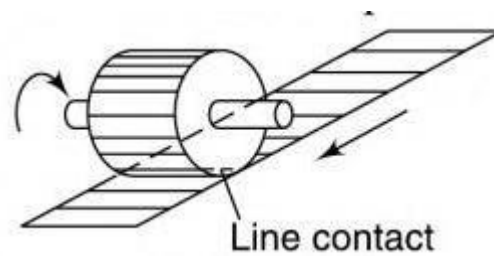

Fig. 5.3(b) Rack and pinion

- **Helical Spur Gears**
 - In helical gears, the teeth are curved, each being helical in shape. Two mating gears have the same helix angle, but have teeth of opposite hands.
 - At the beginning of engagement, contact occurs only at the point of leading edge of the curved teeth. As the gears rotate, the contact extends along a diagonal line across the teeth. Thus, the load application is gradual which results in low impact stresses and reduction in noise. Therefore, the helical gear can be used at higher velocities than the spur gears and have greater load-carrying capacity.
 - Helical gears have the **disadvantage** of having end thrust as there is a force component along the gear axis. The bearing and assemblies mounting the helical gears must be able to withstand thrust loads.
 - **Double helical:** A double-helical gear is equivalent to a pair of helical gears secured together, one having a right hand helix and other left hand helix.
 - The teeth of two rows are separated by groove used for tool run out.
 - Axial thrust which occurs in case of single-helical gears is eliminated in double-helical gears.
 - This is because the axial thrusts of the two rows of teeth cancel each other out. These can be run at high speeds with less noise and vibrations.
 - **Herringbone gear:** If the left and the right inclinations of a double-helical gear meet at a common apex and there is no groove in between, the gear is known as Herringbone gear.

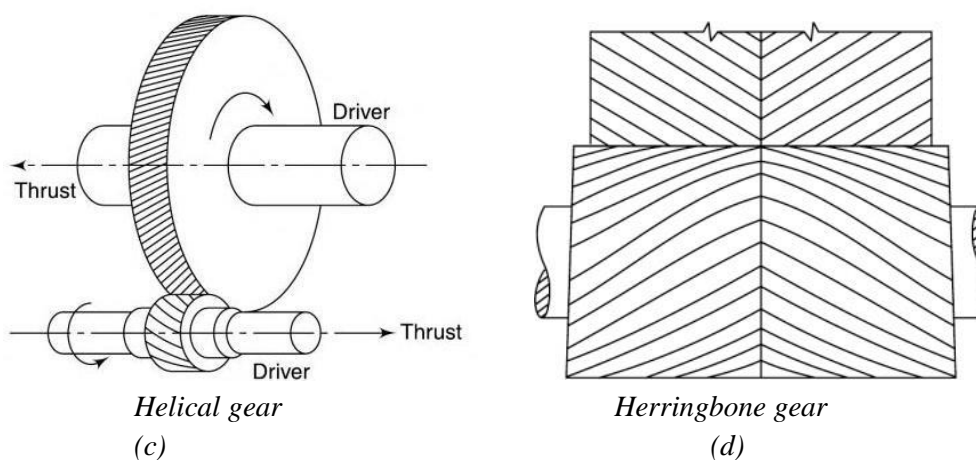

Fig. 5.3

B. Intersecting Shafts

- The two non-parallel or intersecting, but coplanar shafts connected by gears are called **bevel gears**
- When teeth formed on the cones are straight, the gears are known as bevel gears when inclined, they are known as **spiral** or **helical bevel**.

- **Straight Bevel Gears** (<http://www.bevelgear.co.za>)

- The teeth are straight, radial to the point of intersection of the shaft axes and vary in cross section throughout their length.
- Usually, they are used to connect shafts at right angles which run at low speeds
- Gears of the same size and connecting two shafts at right angles to each other are known as “Mitre” gears.

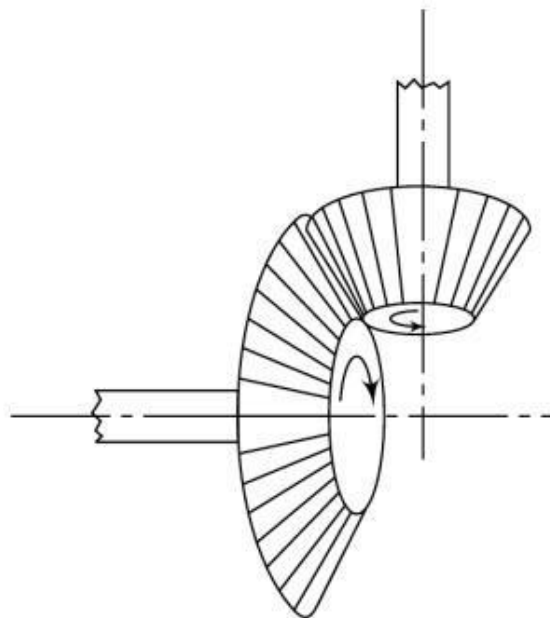

Fig. 5.3(e) Straight Bevel Gears

- **Spiral Bevel Gears**

- When the teeth of a bevel gear are inclined at an angle to the face of the bevel, they are known as spiral bevels or helical bevels.
- They are smoother in action and quieter than straight tooth bevels as there is gradual load application and low impact stresses. Of course, there exists an axial thrust calling for stronger bearings and supporting assemblies.
- These are used for the drive to the differential of an automobile.

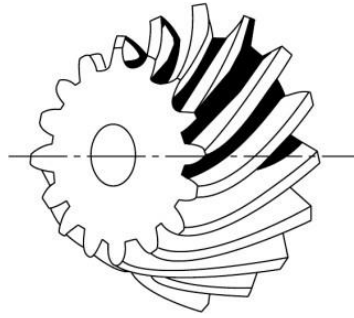

Fig. 5.3(f) Spiral Bevel Gear

- *Zero Bevel Gears*
 - Spiral bevel gears with curved teeth but with a zero degree spiral angle are known as zero bevel gears.
 - Their tooth action and the end thrust are the same as that of straight bevel gears and, therefore, can be used in the same mountings.
 - However, they are quieter in action than the straight bevel type as the teeth are curved.

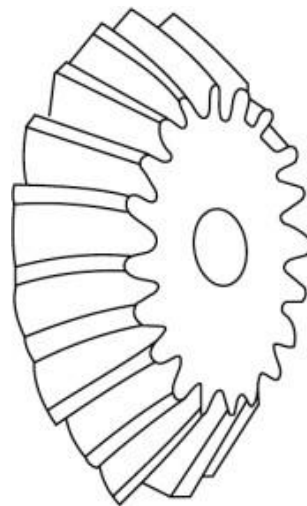

Fig. 5.3(g) Zero Bevel Gears

C. Non-intersecting and non-parallel shaft(Skew shaft)

- The two non-intersecting and non-parallel i.e. non-coplanar shaft connected by gears are called skew bevel gears or spiral gears and the arrangement is known as skew bevel gearing or spiral gearing.
- In these gears teeth have a point contact.
- These gears are suitable for transmitting small power.
- **Worm gear** is as special case of a spiral gear in which the larger wheel, usually, has a hollow shape such that a portion of the pitch diameter of the other gear is enveloped on it.

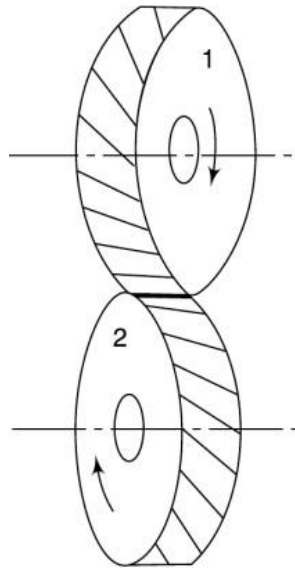

Fig.5.3 (h) Non-intersecting and non-parallel shaft

5.3.2. According to the peripheral velocity of the gears

- (a) Low velocity $V < 3$ m/sec
- (b) Medium velocity $3 < V < 15$ m/sec
- (c) High velocity $V > 15$ m/sec

5.3.3. According to position of teeth on the gear surface

- (a) Straight,
- (b) Inclined, and
- (c) Curved.

5.4 Terms Used in Gears

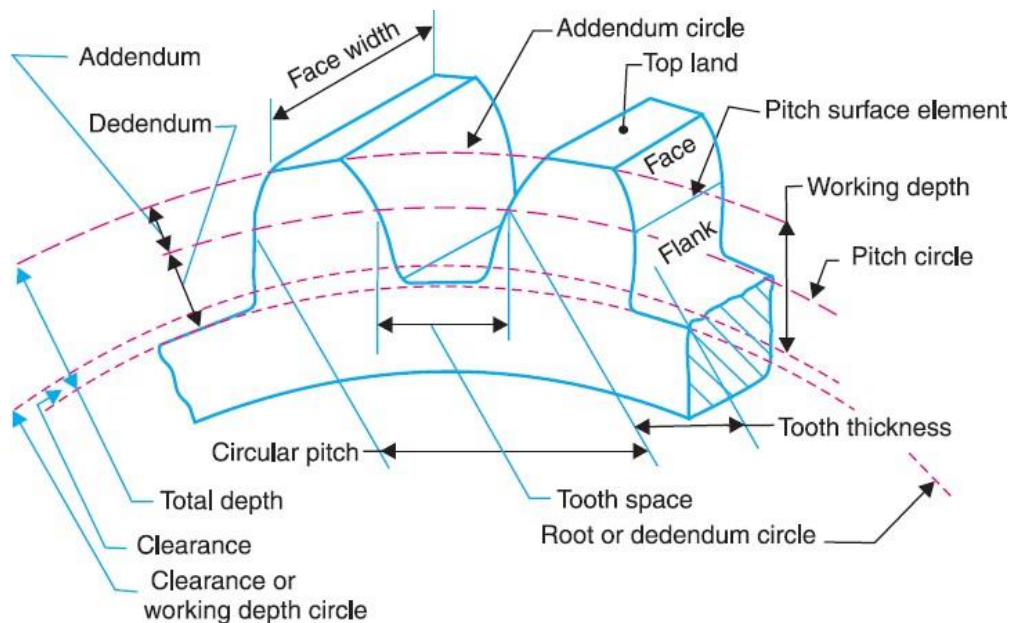

Fig.5.4 Terms used in gears.

1. Pitch circle. It is an imaginary circle which by pure rolling action, would give the same motion as the actual gear.

2. Pitch circle diameter. It is the diameter of the pitch circle. The size of the gear is usually specified by the pitch circle diameter. It is also known as **pitch diameter**.

3. Pitch point. It is a common point of contact between two pitch circles.

4. Pitch surface. It is the surface of the rolling discs which the meshing gears have replaced at the pitch circle.

5. Pressure angle or angle of obliquity. It is the angle between the common normal to two gear teeth at the point of contact and the common tangent at the pitch point.

- For more power transmission lesser pressure on the bearing and pressure angle must be kept small.
- It is usually denoted by ϕ .
- The standard pressure angles are 20° and 25° . Gears with pressure angle has become obsolete.

6. Addendum. It is the radial distance of a tooth from the pitch circle to the top of the tooth.

- Standard value = 1 module

7. Dedendum. It is the radial distance of a tooth from the pitch circle to the bottom of the tooth.

- Standard value = 1.157 module

8. Addendum circle. It is the circle drawn through the top of the teeth and is concentric with the pitch circle.

9. Dedendum circle. It is the circle drawn through the bottom of the teeth. It is also called root circle.

10. Clearance. It is the radial difference between the addendum and the Dedendum of a tooth.

$$\text{Addendum circle diameter} = d + 2m$$

$$\text{Dedendum circle diameter} = d - 2 \times 1.157m$$

$$\begin{aligned} \text{Clearance} &= 1.157m - m \\ &= 0.157m \end{aligned}$$

11. Full depth of Teeth It is the total radial depth of the tooth space.

$$\text{Full depth} = \text{Addendum} + \text{Dedendum}$$

12. Working Depth of Teeth The maximum depth to which a tooth penetrates into the tooth space of the mating gear is the working depth of teeth.

- Working depth = Sum of addendums of the two gears.

15. Working depth. It is the radial distance from the addendum circle to the clearance circle. It is equal to the sum of the addendum of the two meshing gears.

16. Tooth thickness. It is the width of the tooth measured along the pitch circle.

17. Tooth space. It is the width of space between the two adjacent teeth measured along the pitch circle.

18. Backlash. It is the difference between the tooth space and the tooth thickness, as measured along the pitch circle. Theoretically, the backlash should be zero, but in actual practice some backlash must be allowed to prevent jamming of the teeth due to tooth errors and thermal expansion.

19. Face of tooth. It is the surface of the gear tooth above the pitch surface.

20. Flank of tooth. It is the surface of the gear tooth below the pitch surface.

21. Top land. It is the surface of the top of the tooth.

22. Face width. It is the width of the gear tooth measured parallel to its axis.

20. Fillet It is the curved portion of the tooth flank at the root circle.

21. Circular pitch. It is the distance measured on the circumference of the pitch circle from point of one tooth to the corresponding point on the next tooth.

- It is usually denoted by p_c .

Mathematically,

$$\text{Circular pitch, } p_c = \frac{\pi d}{T}$$

Where d = Diameter of the pitch circle, and

T = Number of teeth on the wheel.

- The angle subtended by the circular pitch at the center of the pitch circle is known as the **pitch angle**.

22. Module (m). It is the ratio of the pitch diameter in mm to the number of teeth.

$$m = \frac{d}{T}$$

$$\text{Also } p_c = \frac{\pi d}{T} = \pi m$$

- Pitch of two mating gear must be same.

23. Diametral Pitch (P) It is the number of teeth per unit length of the pitch circle diameter in inch.

OR

It is the ratio of no. of teeth to pitch circle diameter in inch.

$$P_d = \frac{T}{d}$$

- The recommended series of modules in Indian Standard are 1, 1.25, 1.5, 2, 2.5, 3, 4, 5, 6, 8, 10, 12, 16, and 20. The modules 1.125, 1.375, 1.75, 2.25, 2.75, 3.5, 4.5, 5.5, 7, 9, 11, 14 and 18 are of second choice.

24. Gear Ratio (G). It is the ratio of the number of teeth on the gear to that on the pinion.

$$G = \frac{T}{t} \quad \text{Where } T = \text{No of teeth on gear}$$

t = No. of teeth on pinion

25. Velocity Ratio (VR) The velocity ratio is defined as the ratio of the angular velocity of the follower to the angular velocity of the driving gear.

$$VR = \frac{\omega_2}{\omega_1} = \frac{N_2}{N_1} = \frac{d_1}{d_2} = \frac{T_1}{T_2}$$

26. Length of the path of contact. It is the length of the common normal cut-off by the Addendum circles of the wheel and pinion.

OR

The locus of the point of contact of two mating teeth from the beginning of engagement to the end of engagement is known as the contact.

- a. **Path of Approach** Portion of the path of contact from the beginning of the engagement to the pitch point.
- b. **Path of Recess** Portion of the path of contact from the pitch point to the end of engagement.

27. Arc of Contact The locus of a point on the pitch circle from the beginning to the end of engagement of two mating gears is known as the arc of contact.

- a. **Arc of Approach** It is the portion of the arc of contact from the beginning of engagement to the pitch point.
- b. **Arc of Recess** The portion of the arc of contact from the pitch point to the end of engagements the arc of recess.

28. Angle of Action (δ) It is the angle turned by a gear from the beginning of engagement to the end of engagement of a pair of teeth, i.e., the angle turned by arcs of contact of respective gear wheels.

$$\delta = \alpha + \beta \text{ Where } \alpha = \text{Angle of approach} \\ \beta = \text{Angle of recess}$$

29. Contact ratio .It is the angle of action divided by the pitch angle

$$\text{Contact ratio} = \frac{\delta}{\gamma} = \frac{\alpha + \beta}{\gamma}$$

OR

$$\text{Contact ratio} = \frac{\text{Arc of contact}}{\text{Circular pitch}}$$

5.5 Condition for Constant Velocity Ratio of Toothed Wheels –Law of Gearing

- To understand the theory consider the portions of two gear teeth gear 1 and gear 2 as shown in figure 1.5.
- The two teeth come in contact at point C and the direction of rotation of gear 1 is anticlockwise & gear 2 is clockwise.
- Let TT be the common tangent & NN be the common normal to the curve at the point of contact C. From points O, & O₂, draw O₁ A & O₂ B perpendicular to common normal NN.
- When the point D is consider on gear 1, the point C moves in the direction of “CD” & when it is consider on gear 2. The point C moves in direction of “CE”.
- The relative motion between tooth surfaces along the common normal NN must be equal to zero in order to avoid separation.
- So, relative velocity

$$V_1 \cos \alpha = V_2 \cos \theta$$

$$(\omega_1 \times O_1 C) \cos \alpha = (\omega_2 \times O_2 C) \quad (\because v = r\omega) \quad \dots\dots(1)$$

$$\cos \alpha$$

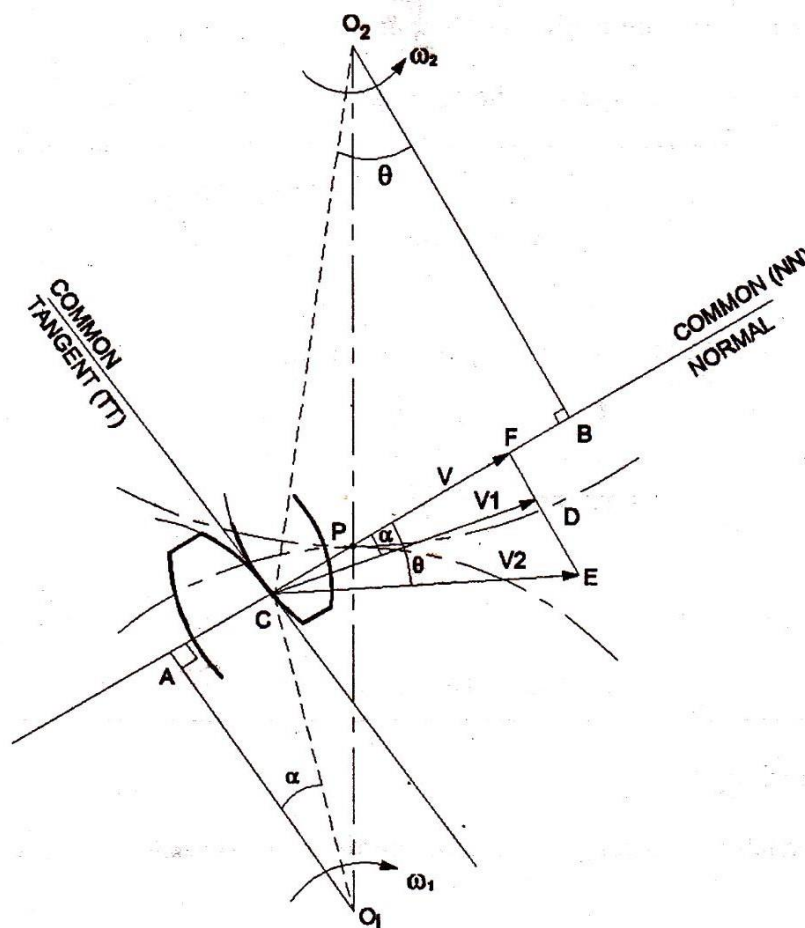

Fig.5.5 Law of gearing

- But from $\Delta O_1 AC$, $\cos\alpha = \frac{O_1 A}{O_1 C}$
 and from $\Delta O_2 BC$, $\cos\theta = \frac{O_2 B}{O_2 C}$

- Putting above value in equation (1) it become

$$\left(\omega_1 \times O_1 C\right) \frac{O_1 A}{O_1 C} = \left(\omega_2 \times O_2 C\right) \frac{O_2 B}{O_2 C}$$

$$\omega_1 \times O_1 A = \omega_2 O_2 B$$

$$\frac{\omega_1}{\omega_2} = \frac{O_2 B}{O_1 A} \dots\dots\dots (2)$$

- From the similar triangle $\Delta O_1 AP$ & $\Delta O_2 BP$

$$\frac{O_2 B}{O_1 A} = \frac{O_2 P}{O_1 P} \dots\dots\dots (3)$$

- Now equating equation (2) & (3)

$$\frac{\omega_1}{\omega_2} = \frac{O_2 B}{O_1 A} = \frac{O_2 P}{O_1 P} = \frac{PB}{AP}$$

- From the above we can conclude that the angular velocity ratio is inversely proportional to the ratio of the distances of the point P from the central O_1 & O_2 .
 – If it is desired that the angular velocities of two gear remain constant, the common normal at the point of contact of two teeth always pass through a fixed point P. This fundamental condition is called as law of gearing. Which must be satisfied while designing the profiles of teeth for gears.

5.6 Standard Tooth Profiles or Systems

Following four types of tooth profiles or systems are commonly used in practice for interchangeability:

- a) $14\frac{1}{2}^\circ$ composite system.
 - 2° full depth involute system.
 - b) $14\frac{1}{2}^\circ$
 - 2°
 - c) 20° full depth involute system.
 - d) 20° stub involute system.
- a) $14\frac{1}{2}^\circ$ composite system:

- This type of profile is made with circular arcs at top and bottom portion and middle portion is a straight line as shown in Fig. 1.6(a).
- The straight portion corresponds to the involute profile and the circular arc portion corresponds to the cycloidal profile.
- Such profiles are used for general purpose gears.

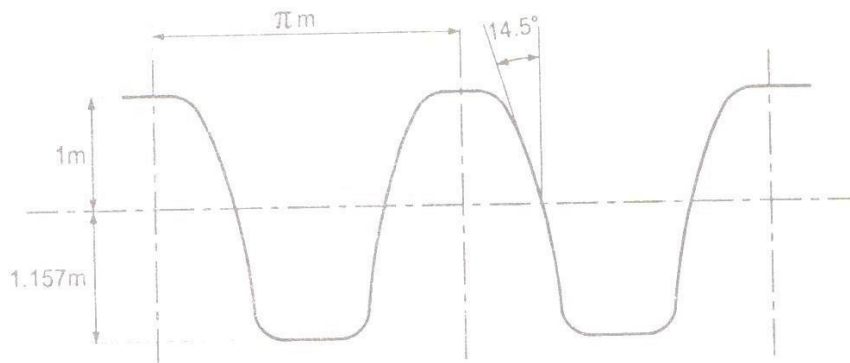

Fig.5.6(a) $14\frac{1}{2}^\circ$ composite system

b) $14\frac{1}{2}^\circ$ full depth involute system:

- This type of profile is made straight line except for the fillet arcs.
- The whole profile corresponds to the involute profile. Therefore manufacturing of such profile is easy but they have interface problem.

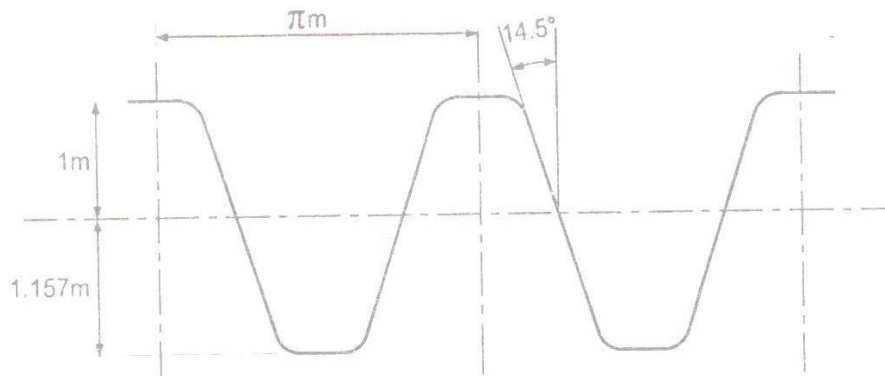

Fig.5.6(b) $14\frac{1}{2}^\circ$ full depth involute system

c) 20° full depth involute system:

- This type of profile is same as $14\frac{1}{2}^\circ$ full depth involute system except the pressure angle.

- The increase of pressure angle from $14\frac{1}{2}^\circ$ to 20° results in a stronger tooth, since the tooth acting as a beam is wider at the base.
- This type of gears also have interference problem if number of teeth is less.

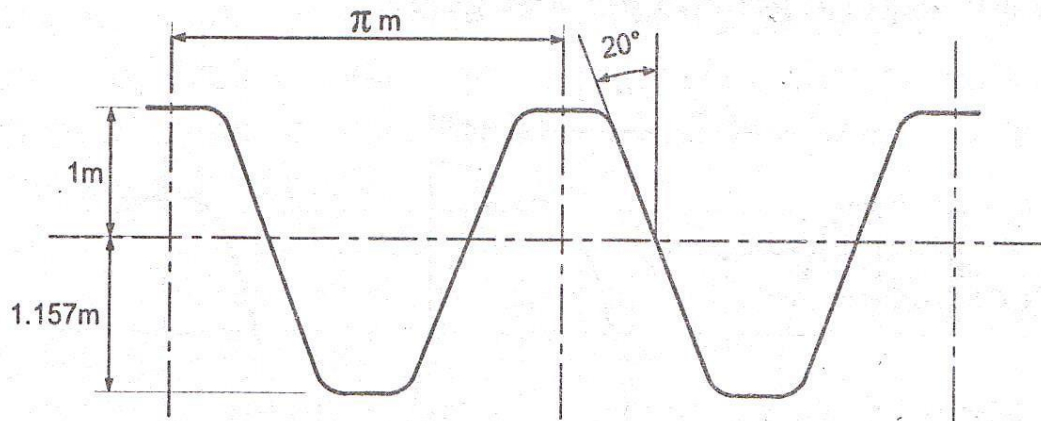

Fig.5.6(c) 20° full depth involute system

d) 20° stub involute system:

- The problem of interference in 20 full depth involute system is minimized by removing extra addendum of gear tooth which causes interference.
- Such modified tooth profile is called “Stub tooth profile”.
- This type of gears are used for heavy load.

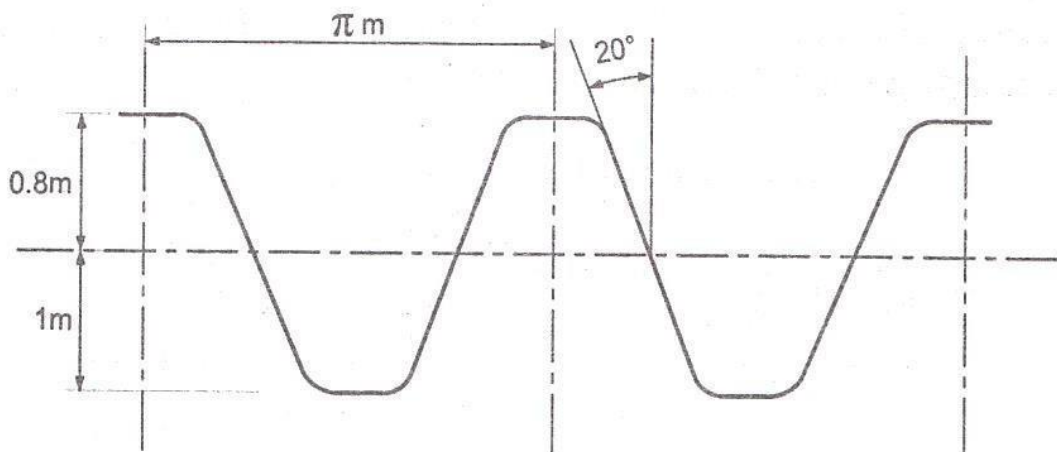

Fig.5.6(d) 20° stub involute system

5.7 Length of Path of Contact And Length of Arc of Contact

5.7.1 Length of Path of Contact

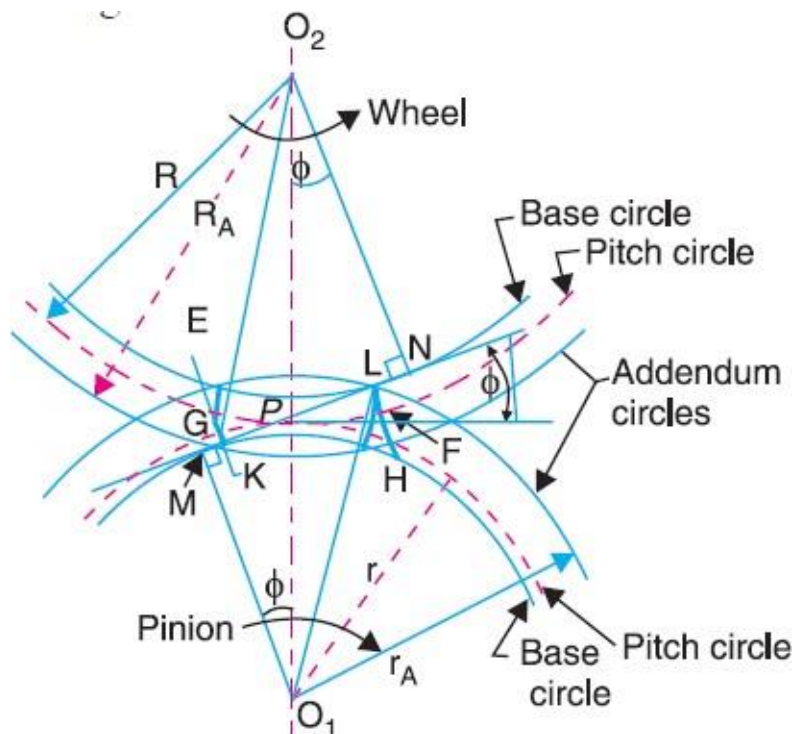

Fig.5.7 Length of path of contact

- When the pinion rotates in clockwise direction, the contact between a pair of involute teeth begins at K (on the flank near the base circle of pinion or the outer end of the tooth face on the wheel) and ends at L (on the flank near the base circle of wheel).
- MN is the common normal at the point of contacts and the common tangent to the base circles.
- The point K is the intersection of the addendum circle of wheel and the common tangent.
- The point L is the intersection of the addendum circle of pinion and common tangent.
- **Length of path of contact** is the length of common normal cutoff by the addendum circles of the wheel and the pinion.
- Thus the length of path of contact is KL which is the sum of the parts of the path of contacts KP and PL. The part of the path of contact KP is known as **path of approach** and the part of the path of contact PL is known as **path of recess**.

$$\begin{aligned} \text{L.P.C} &= \text{KL} \\ &= \text{KP} + \text{PL} \end{aligned}$$

Where, KP = path of approach
PL = path of recess

Let

$R = O_2P$ = pitch circle radius of wheel

$R_A = O_2K$ = addendum circle radius of

wheel $r = O_1P$ = pitch circle radius of
pinion

$r_A = O_1L$ = addendum circle radius of pinion

Length of the path of contact = Path of approach + path of recess

$$= KP + PL$$

$$= (KN - PN) + (ML - MP)$$

$$= \left(\sqrt{O_2K^2 - O_2P^2} - PN \right) + \left(\sqrt{O_1L^2 - O_1P^2} - MP \right)$$

$$= \left(\sqrt{R_A^2 - (R \cos \phi)^2} - R \sin \phi \right) + \left(\sqrt{r_A^2 - (r \cos \phi)^2} - r \sin \phi \right)$$

(

5.7.2 Length of Arc of Contact

- The arc of contact is the path traced by a point on the pitch circle from the beginning to the end of engagement of a given pair of teeth.
- The arc of contact is EPF or GPH.
- Considering the arc of contact GPH, it is divided into two parts i.e. arc GP and arc PH. The arc GP is known as **arc of approach** and the arc PH is called **arc of recess**.
- The angles subtended by these arcs at O1 are called **angle of approach** and **angle of recess** respectively.

$$\text{Length of the arc of contact GPH} = (GP + PH)$$

$$= \text{Arc of approach} + \text{Arc of recess}$$

$$= \frac{KP}{\cos \phi} + \frac{PL}{\cos \phi}$$

$$= \frac{KP + PL}{\cos \phi}$$

$$= \frac{KL}{\cos \phi}$$

$$= \frac{\text{Length of path of contact}}{\cos \phi}$$

Contact Ratio (or Number of Pairs of Teeth in Contact)

- The contact ratio or the number of pairs of teeth in contact is defined as the ratio of the length of the arc of contact to the circular pitch.

Mathematically,

Contact ratio or number of pairs of teeth in contact

$$= \frac{\text{Length of arc of contact}}{\text{Circular pitch}}$$

$$= \frac{\text{Length of arc of contact}}{\pi m}$$

Note:

- For continuous transmission of the motion, at least one tooth of any one wheel must be in contact with another tooth of second wheel so 'n' must be greater than unity.
- If 'n' lies between 1 & 2, no. of teeth in contact at any time will not be less than one and will never mate two.
- If 'n' lies between 2 & 3, it is never less than two pair of teeth and not more than three pairs and so on.
- If 'n' is 1.6, one pair of teeth are always in contact where as two pair of teeth are in contact for 60% of the time

5.8 Interference in Involute Gears

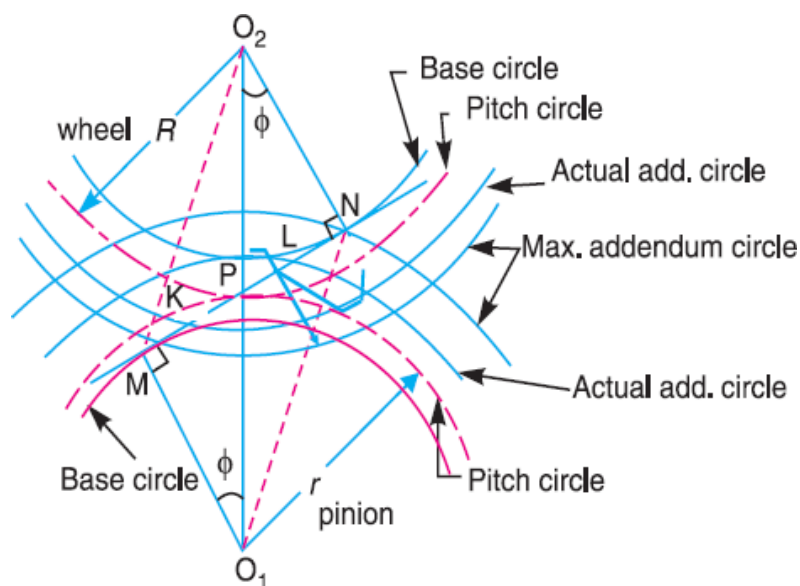

Fig.5.8 Interference in involute gears

- Fig. shows a pinion with center O_1 , in mesh with wheel or gear with centre O_2 . MN is the common tangent to the base circles and KL is the path of contact between the two mating teeth.
- A little consideration will show that if the radius of the addendum circle of pinion is increased to O_1N , the point of contact L will move from L to N . When this radius is further increased, the point of contact L will be on the inside of base circle of wheel and not on the involute profile of tooth on wheel. The tip of tooth on the pinion will then undercut the tooth on the wheel at the root and remove part of the involute profile of tooth on the wheel. This effect is known as **interference**, and occurs when the teeth are being cut. In brief, the phenomenon when the tip of tooth undercuts the root on its mating gear is known as interference.
- Similarly, if the radius of the addendum circles of the wheel increases beyond O_2M , then the tip of tooth on wheel will cause interference with the tooth on pinion.
- The points M and N are called **interference points**. Interference may be avoided if the path of contact does not extend beyond interference points. The limiting value of the radius of the addendum circle of the pinion is O_1N and of the wheel is O_2M .

How to avoid interference?

- The interference may only be avoided, if the point of contact between the two teeth is always on the involute profiles of both the teeth.
- OR
- Interference may only be prevented, if the addendum circles of the two mating gears cut the common tangent to the base circles between the points of tangency.
- When interference is just avoided, the maximum length of path of contact is MN

$$\text{Maximum length of path of contact} = MN$$

$$= MP + PN$$

$$= r \sin\phi + R \sin\phi$$

$$= (r + R) \sin\phi$$

$$\text{Maximum length of arc of contact} = \frac{(r + R) \sin\phi}{\cos\phi}$$

Note:

In case the addenda on pinion and wheel is such that the path of approach and path of recess are half of their maximum possible values, then

- Path of approach, $KP = \frac{1}{2}$

$$\left(\sqrt{R_A^2 - (R \cos \phi)^2} - R \sin \phi \right) = \frac{1}{2} r \sin \phi$$

- Path of recess, $PL = \frac{1}{2} PN$

$$\left(\sqrt{r_A^2 - (r \cos \phi)^2} + r \sin \phi \right) = \frac{1}{2} R \sin \phi$$

- Length of the path of contact = KP + PL

$$= \frac{1}{2} MP + \frac{1}{2} PN$$

$$= \frac{(r + R) \sin \phi}{2}$$

5.9 Minimum Number of Teeth on the Pinion in Order to Avoid Interference

- In order to avoid interference, the addendum circles for the two mating gears must cut the common tangent to the base circles between the points of tangency.
- The limiting condition reaches, when the addendum circles of pinion and wheel pass through points N and M (see Fig.) respectively.

Let

- t = Number of teeth on the pinion,
- T = Number of teeth on the wheel,
- m = Module of the teeth,
- r = Pitch circle radius of pinion = $mt / 2$
- G = Gear ratio = $T / t = R / r$
- ϕ = Pressure angle or angle of obliquity.

From O_1NP ,

$$O_1N^2 = O_1P^2 + PN^2 - 2OP \times PN \cos(QPN)$$

$$\therefore O_1 N^2 = r^2 + (R \sin \phi)^2 - 2r(R \sin \phi) \times \cos(90 + \phi)$$

$$\therefore O_1 N^2 = r^2 + (R \sin \phi)^2 - 2r(R \sin \phi) \times \cos(90 + \phi)$$

$$\therefore O_1 N^2 = r^2 + R^2 \sin^2 \phi + 2rR \sin^2 \phi$$

$$\therefore O_1 N = r \sqrt{1 + \frac{R^2 \sin^2 \phi}{r^2} + \frac{2R \sin^2 \phi}{r}}$$

$$\therefore O_1 N^2 = r^2 \left[1 + \frac{R^2 \sin^2 \phi}{r^2} + \frac{2R \sin^2 \phi}{r} \right]$$

$$\therefore O_1 N = r \sqrt{1 + \frac{R}{r} \left(\frac{R}{r} + 2 \right) \sin^2 \phi}$$

$$\therefore O_1 N = r \sqrt{1 + \frac{R}{r} \left(\frac{R}{r} + 2 \right) \sin^2 \phi}$$

$$\therefore O_1 N = \frac{mt}{2} \sqrt{1 + \frac{R}{r} \left(\frac{R}{r} + 2 \right) \sin^2 \phi}$$

Let $A_p \cdot m$ = Addendum of the pinion, where A_p is a fraction by which the standard addendum of one module for the pinion should be multiplied in order to avoid interference.

Addendum of the pinion = $O_1 N - O_1 P$

$$A_p \cdot m = \frac{mt}{2} \sqrt{1 + \frac{T}{t} \left(\frac{T}{t} + 2 \right) \sin^2 \phi} - \frac{mt}{2}$$

$$\therefore A_p \cdot m = \frac{mt}{2} \sqrt{1 + \frac{T}{t} \left(\frac{T}{t} + 2 \right) \sin^2 \phi} - \frac{mt}{2}$$

$$\therefore A_p \cdot m = \frac{mt}{2} \left[\sqrt{1 + \frac{T}{t} \left(\frac{T}{t} + 2 \right) \sin^2 \phi} - 1 \right]$$

$$\therefore A_p . m = \frac{mt}{2} \left[\sqrt{1 + \frac{T}{t} \left(\frac{T}{t} + 2 \right) \sin^2 \phi} - 1 \right]$$

$$\therefore A_p = \frac{t}{2} \left[\sqrt{1 + \frac{T}{t} \left(\frac{T}{t} + 2 \right) \sin^2 \phi} - 1 \right]$$

$$\therefore A_p = \frac{t}{2} \left[\sqrt{1 + \frac{T}{t} \left(\frac{T}{t} + 2 \right) \sin^2 \phi} - 1 \right]$$

$$\therefore A_p = \frac{t}{2} \left[\sqrt{1 + \frac{T}{t} \left(\frac{T}{t} + 2 \right) \sin^2 \phi} - 1 \right]$$

$$\therefore t = \frac{2A_p}{\left[\sqrt{1 + \frac{T}{t} \left(\frac{T}{t} + 2 \right) \sin^2 \phi} - 1 \right]}$$

$$\therefore t = \frac{2A_p}{\left[\sqrt{1 + G(G+2) \sin^2 \phi} - 1 \right]}$$

Note:

- If the pinion and wheel have equal teeth, then $G = 1$.

$$\therefore t = \frac{2A_p}{\left[\sqrt{1 + 3 \sin^2 \phi} - 1 \right]}$$

Min. no of teeth on pinion

Sr. no	System of gear teeth	Min. no of teeth on pinion
1	Composite	12
2	Full depth involute	32
3	Full depth involute	18
4	Stub involute	14

5.10 Minimum Number of Teeth on the Wheel in Order to Avoid Interference

Let T = Minimum number of teeth required on the wheel in order to avoid interference,

$A_w \cdot m$ = Addendum of the wheel, where A_w is a fraction by which the standard Addendum for the wheel should be multiplied.

From O_2MP

$$O_2M^2 = O_2P^2 + PM^2 - 2O_2P \times PM \cos(O_2PM)$$

$$\therefore O_2M^2 = R^2 + (r \sin \phi)^2 - 2r(R \sin \phi) \times \cos(90 + \phi)$$

$$\therefore O_2M^2 = R^2 + r^2 \sin^2 \phi + 2rR \sin^2 \phi$$

$$\therefore O_2M = R \left[1 + \frac{r^2 \sin^2 \phi}{R^2} + \frac{2r \sin^2 \phi}{R} \right]$$

$$\therefore O_2M^2 = R^2 \left[1 + \frac{r}{R} \left(\frac{r}{R} + 2 \right) \sin^2 \phi \right]$$

$$\therefore O_2M = R \sqrt{1 + \frac{r}{R} \left(\frac{r}{R} + 2 \right) \sin^2 \phi}$$

$$\therefore O_2M = \frac{mT}{2} \sqrt{1 + \frac{r}{R} \left(\frac{r}{R} + 2 \right) \sin^2 \phi}$$

Addendum of the wheel = $O_2M - O_2P$

$$A_w m = \frac{mT}{2} \sqrt{1 + \frac{r}{T} \left(\frac{r}{T} + 2 \right) \sin^2 \phi} - \frac{mT}{2}$$

$$\therefore A_w m = \frac{mT}{2} \left[\sqrt{1 + \frac{r}{T} \left(\frac{r}{T} + 2 \right) \sin^2 \phi} - 1 \right]$$

$$\therefore A_m = \frac{mT}{2} \left[\sqrt{1 + \frac{t}{T} \left(\frac{t}{T} + 2 \right) \sin^2 \phi} - 1 \right]$$

$$\therefore A_w = \frac{T}{2} \left[\sqrt{1 + \frac{t}{T} \left(\frac{t}{T} + 2 \right) \sin^2 \phi} - 1 \right]$$

$$\therefore T = \frac{2A_w}{\left[\sqrt{1 + \frac{t}{T} \left(\frac{t}{T} + 2 \right) \sin^2 \phi} - 1 \right]}$$

$$\therefore T = \frac{2A_w}{\left[\sqrt{1 + \frac{1}{G} \left(\frac{1}{G} + 2 \right) \sin^2 \phi} - 1 \right]}$$

Note:

- From the above equation, we may also obtain the minimum number of teeth on pinion. Multiplying both sides by t/T ,

$$T \times \frac{t}{T} = \frac{2A_w \times \frac{t}{T}}{\left[\sqrt{1 + \frac{1}{G} \left(\frac{1}{G} + 2 \right) \sin^2 \phi} - 1 \right]}$$

$$\therefore t = \frac{2A_w}{G \left[\sqrt{1 + \frac{1}{G} \left(\frac{1}{G} + 2 \right) \sin^2 \phi} - 1 \right]}$$

- If wheel and pinion have equal teeth, then $G = 1$,

$$\therefore T = \frac{2A_w}{\left[\sqrt{1 + 3 \sin^2 \phi} - 1 \right]}$$

5.11 Minimum Number of Teeth on a Pinion for Involute Rack in Order to Avoid Interference

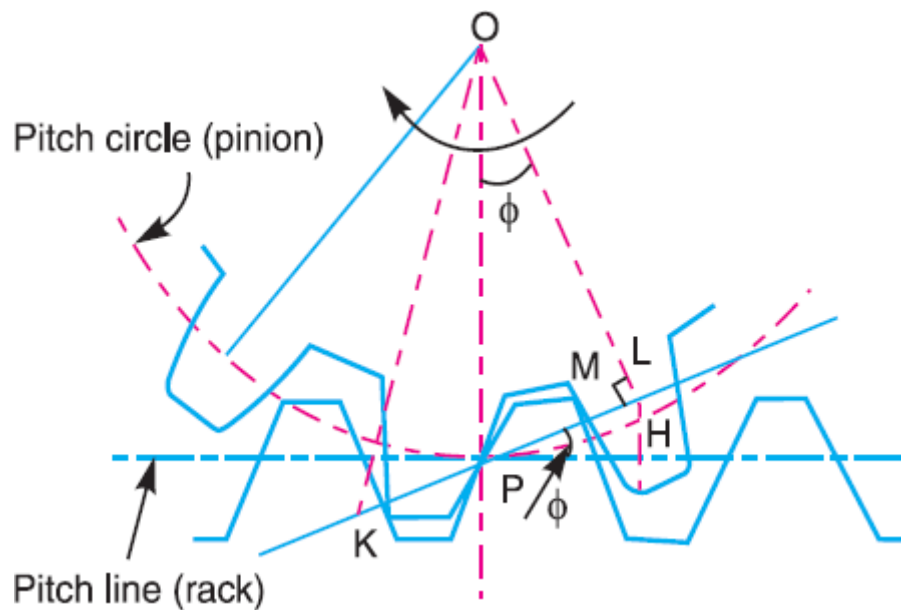

Fig.5.11 Rack and pinion in mesh

Let t = Minimum number of teeth on the pinion,
 r = Pitch circle radius of the pinion $\frac{m \cdot t}{2}$ and
 ϕ = Pressure angle or angle of obliquity, and
 $A_R \cdot m$ = Addendum for rack, where A_R is the fraction by which the standard addendum of one module for the rack is to be multiplied.

$$\text{Addendum for rack, } A_R \cdot m = LH$$

$$\therefore A_R \cdot m = PL \sin \phi$$

$$\therefore A_R \cdot m = r \sin \phi \times \sin \phi$$

$$\therefore A_R \cdot m = r \sin^2 \phi$$

$$\therefore A_R \cdot m = \frac{mt \sin^2 \phi}{2}$$

$$\therefore t = \frac{2A_R}{\sin^2 \phi}$$

Note:

- In case of pinion, max. value of addendum radius to avoid interference if AF

$$= O_2 M^2 + AF^2$$

$$= (r \cos \phi)^2 + (R \sin \phi + r \sin \phi)^2$$

- Max value of addendum of pinion is

$$(A_p)_{\max} = r \sqrt{1 + \frac{R}{r} \left(\frac{R}{r} + 2 \right) \sin^2 \phi} - 1$$

$$= \frac{mt}{2} \left[\sqrt{1 + G(G+2) \sin^2 \phi} - 1 \right]$$

5.12 Comparison of Cycloidal and Involute tooth forms

Cycloidal teeth	Involute teeth
Pressure angle varies from maximum at the beginning of engagement, reduce to zero at the pitch point and again increase to maximum at the end of the engagement resulting in smooth running of gears.	Pressure angle is constant throughout the engagement of teeth. This result in smooth running of the gears.
It involves double curves for the teeth, epicycloid and hypocycloid. This complicates the manufacturer.	It involves the single curves for the teeth resulting in simplicity of manufacturing and of tool
Owing to difficulty of manufacturer, these are costlier	These are simple to manufacture and thus are cheaper.
Exact center distance is required to transmit a constant velocity ratio.	A little variation in a centre distance does not affect the velocity ratio.
Phenomenon of interference does not occur at all.	Interference can occur if the condition of minimum no. of teeth on a gear is not followed.
The teeth have spreading flanks and thus are stronger.	The teeth have radial flanks and thus are weaker as compared to the Cycloidal form for the same pitch.
In this a convex flank always has contact with a concave face resulting in less wear.	Two convex surfaces are in contact and thus there is more wear.

5.13 HELICAL AND SPIRAL GEARS

- In helical and spiral gears, the teeth are inclined to the axis of a gear. They can be right handed or left-handed, depending upon the direction in which the helix slopes away from the viewer when a gear is viewed parallel to the axis of the gear.
- In Fig. Gear1 is a right-handed helical gear whereas 2 are left handed. The two mating gears have parallel axes and equal helix angle α OR ψ . The contact between two teeth on the two gears is first made at one end which extends through the width of the wheel with the rotation of the gears.
- Figure (a) shows the same two gears when looking from above. Now, if the helix angle of the gear 2 is reduced by a few degrees so that the helix angle of the gear 1 is ψ_1 , and that of gear 2 is ψ_2 and it is desired that the teeth of the two gears still mesh with each other tangentially, it is essential to rotate the axis of gear 2 through some angle as shown in Fig. (b).

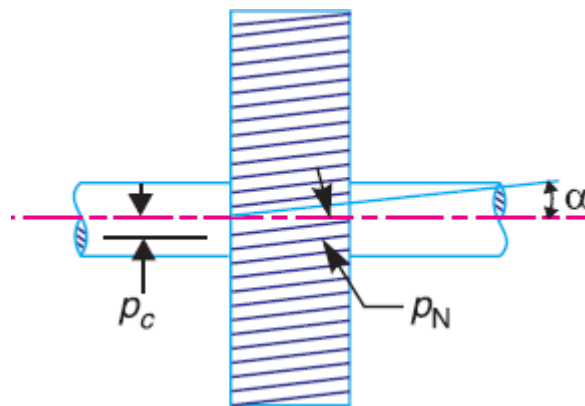

Fig.5.13(a) Helical Gear

- The following definitions may be clearly understood in connection with a helical gear as shown in Fig.

1. Normal pitch. It is the distance between similar faces of adjacent teeth, along a helix on the pitch cylinder normal to the teeth. It is denoted by p_N .

2. Axial pitch. It is the distance measured parallel to the axis, between similar faces of adjacent teeth. It is the same as circular pitch and is therefore denoted by p_c . If α is the helix angle, then

$$\text{Circular pitch, } p_c = \frac{p_N}{\cos \alpha}$$

Note: The **helix angle** is also known as **spiral angle** of the teeth.

Efficiency of Spiral Gears

- A pair of spiral gears 1 and 2 in mesh is shown in Fig. . Let the gear 1 be the driver and the gear 2 the driven. The forces acting on each of a pair of teeth in contact are shown in Fig.
- The forces are assumed to act at the center of the width of each teeth and in the plane tangential to the pitch cylinders

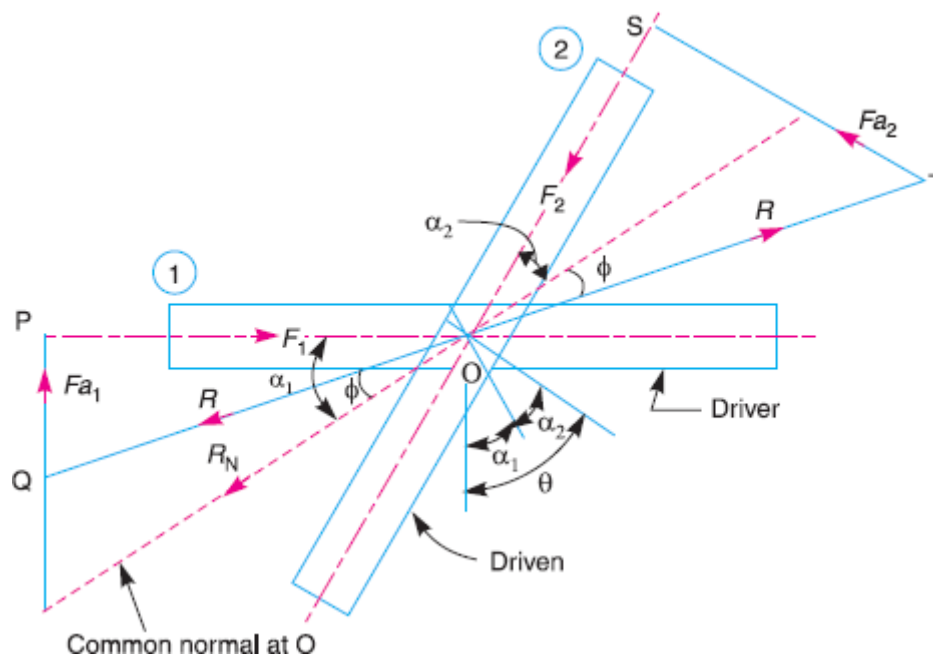

Fig.5.13 (b)

- Let F_1 = Force applied tangentially on the driver,
 F_2 = Resisting force acting tangentially on the driven, F_{a1} = Axial or end thrust on the driver,
 F_{a2} = Axial or end thrust on the driven,
 R_N = Normal reaction at the point of contact
 ϕ = Angle of friction,
 R = Resultant reaction at the point of contact, and
 θ = Shaft angle $= \alpha_1 + \alpha_2$

...(: Both gears are of the same hand)

From triangle OPQ, $F_1 = R \cos(\alpha_1 - \phi)$

\therefore Work input to the driver $= F_1 \times \pi d_1 \cdot N_1 = R \cos(\alpha_1 - \phi) \times \pi d_1 \cdot N_1$

From triangle OST, $F_2 = R \cos(\alpha_2 + \phi)$

\therefore Work output of the driven = $F_2 \times \pi d_2 \cdot N_2 = R \cos(\alpha_2 + \phi) \times \pi d_2 \cdot N_2$

\therefore Efficiency of spiral gears,

$$\eta = \frac{\text{Work output}}{\text{Work input}} = \frac{R \cos(\alpha_2 + \phi) \times \pi d_2 \cdot N_2}{R \cos(\alpha_1 - \phi) \times \pi d_1 \cdot N_1}$$

$$= \frac{\cos(\alpha_2 + \phi) \times d_2 \cdot N_2}{\cos(\alpha_1 - \phi) \times d_1 \cdot N_1}$$

Pitch circle diameter of gear 1,

$$d_1 = \frac{p_{c1} \times T_1}{\pi} = \frac{p_N}{\cos \alpha_1} \times \frac{T_1}{\pi}$$

Pitch circle diameter of gear 2,

$$d_2 = \frac{p_{c2} \times T_2}{\pi} = \frac{p_N}{\cos \alpha_2} \times \frac{T_2}{\pi}$$

$$\therefore \frac{d_2}{d_1} = \frac{T_2 \cos \alpha_1}{T_1 \cos \alpha_2} \quad \dots\dots\dots(2)$$

$$\frac{N_2}{N_1} = \frac{T_1}{T_2} \quad \dots\dots\dots(3)$$

Multiplying equation (2) and (3) we get

$$\frac{d_2 N_2}{d_1 N_1} = \frac{\cos \alpha_1}{\cos \alpha_2}$$

Substituting this value in equation (1)

$$\eta = \frac{\cos(\alpha_2 + \phi) \times \cos \alpha_1}{\cos(\alpha_1 - \phi) \times \cos \alpha_2} \quad \dots\dots\dots(4)$$

$$= \frac{\cos(\alpha_1 + \alpha_2 + \phi) + \cos(\alpha_1 - \alpha_2 - \phi)}{\cos(\alpha_1 + \alpha_2 - \phi) + \cos(\alpha_1 - \alpha_2 + \phi)}$$

$$\left(\because \cos A \cdot \cos B = \frac{1}{2} [\cos(A+B) + \cos(A-B)] \right)$$

$$= \frac{\cos(\theta + \phi) + \cos(\alpha_1 - \alpha_2 - \phi)}{\cos(\theta - \phi) + \cos(\alpha_1 - \alpha_2 + \phi)} \quad \dots\dots\dots(5)$$

$$(\because \theta = \alpha_1 + \alpha_2)$$

Since the angle θ and ϕ are constants, therefore the efficiency will be maximum, when $\cos(\alpha_1 - \alpha_2 + \phi)$ is maximum *i.e.*

$$\cos(\alpha_1 - \alpha_2 + \phi) = 1$$

$$\therefore \alpha_1 - \alpha_2 + \phi = 0$$

$$\therefore \alpha_1 = \alpha_2 - \phi \quad \text{and} \quad \alpha_2 = \alpha_1 + \phi$$

Since $\alpha_1 + \alpha_2 = \theta$ therefore

$$\alpha_1 = \theta - \alpha_2 = \theta - \alpha_1 + \phi \quad \text{OR} \quad \alpha_1 = \frac{\theta + \phi}{2}$$

Similarly

$$\alpha_2 = \frac{\theta - \phi}{2}$$

Substituting $\alpha_1 = \alpha_2 + \phi$ and $\alpha_2 = \alpha_1 - \phi$ in equation (5) we get

$$\eta_{\max} = \frac{\cos(\theta + \phi) + 1}{\cos(\theta - \phi) + 1}$$

EXAMPLES

Example 5.1: Two spur gears have a velocity ratio of 1/3 the driven gear has 72 teeth of 8 mm module and rotates at 300 rpm. Calculate the number of teeth and Speed of driver. What will be the pitch line velocity?

Solution:

Given data	Find
VR = 1/3	$V_p = ?$
=	
$T_2 = 72$ teeth	$T_1 = ?$
$m = 8$ mm	
$N_2 = 300$	

$$VR = \frac{N_2}{N_1} = \frac{T_1}{T_2}$$

$$\therefore \frac{1}{3} = \frac{300}{N_1} = \frac{T_1}{72}$$

$$\therefore T_1 = 24 \text{ \& } N_1 = 900 \text{ rpm}$$

Pitch line velocity

$$V_p = r_1 \omega_1 = r_2 \omega_2$$

$$= \frac{2\pi N_1}{60} \times \frac{d_1}{2}$$

$$= \frac{2\pi N_1}{60} \times \frac{mT_1}{2}$$

$$= \frac{2\pi \times 900}{60} \times \frac{8 \times 24}{2}$$

$$= 9047.78 \text{ mm / sec}$$

Example 5.2: The number of teeth of a spur gear is 30 and it rotates at 200 rpm. What will be its circular pitch and the pitch line velocity if it has a module of 2 mm?

Solution:

Given data	Find:
$T = 30$	$P_c = ?$
$N = 200 \text{ rpm}$	$V_p = ?$
$m = 2 \text{ mm}$	

Circular pitch	$P_c = \pi \cdot m$
	$= \pi \cdot 2$
	$= 6.28 \text{ mm}$

Pitch line velocity	$V_p = \omega \cdot r$
	$= \frac{2\pi N}{60} \times \frac{d}{2}$
	$= \frac{2\pi \times 200}{60} \times \frac{2 \times 30}{2}$
	$= 628.3 \text{ mm/s}$

Example 5.3: The following data relate to two meshing gears velocity ratio = 1/3, module = 1 mm, Pressure angle 20° , center distance = 200 mm. Determine the number of teeth and the base circle radius of the gear wheel.

Solution:

Given data	Find:
$VR = 1/3$	$T_1 = ?$
$\phi = 20^\circ$	$T_2 = ?$
$C = 200 \text{ mm}$	Base circle radius of gear wheel = ?
$m = 1 \text{ mm}$	

$$(1) \quad VR = \frac{N_2}{N_1} = \frac{1}{3} = \frac{T_1}{T_2}$$

$$\therefore T_2 = 3T_1 \quad \dots\dots\dots(1)$$

$$\text{Centre distance } C = \frac{d_1 + d_2}{2}$$

$$\therefore 200 = \frac{m(T_1 + T_2)}{2} \quad \left(m = \frac{d}{T} \right)$$

$$\therefore 200 = \frac{4(T_1 + T_2)}{2}$$

$$\therefore T_1 + T_2 = 100 \quad \dots\dots\dots(2)$$

By solving equation (1) & (2)

$$T_1 = 25$$

$$T_2 = 75$$

(2) No of teeth of gear wheel $T_2 = 75$

$$\text{But } m = \frac{d_2}{T_2}$$

$$\therefore d_2 = mT_2$$

$$\therefore d_2 = 300\text{mm}$$

$$\text{Base circle radius } d_{b2} = \frac{d_2}{2} \cos \phi$$

$$= \frac{300}{2} \times \cos 20^\circ$$

$$= 141\text{mm}$$

Example 5.4: Each of the gears in a mesh has 48 teeth and a module of 8 mm. The teeth are of 20° involute profile. The arc of contact is 2.25 times the circular pitch. Determine the addendum.

Solution:

Given data

$$T = t = 48$$

$$m = 8 \text{ mm}$$

$$\phi = 20^\circ$$

$$\text{Arc of contact} = 2.25 P_c$$

$$\text{Arc of contact} = 2.25P_c$$

$$= 2.25 \times \pi m$$

$$= 2.25 \times \pi \times 8$$

$$= 56.55 \text{ mm}$$

$$\text{Let } m = \frac{d}{t} = \frac{2r}{T}$$

$$\therefore R = r = \frac{mT}{2} = \frac{8 \times 48}{2}$$

$$\therefore R = r = 192 \text{ mm}$$

$$\text{Also } R_a = r_a$$

(:tooth sizes same)

$$\frac{\text{L.A.C}}{\text{L.P.C}} = \frac{\cos \phi}{\cos \phi}$$

$$\therefore 56.55 = \frac{\text{L.P.}}{\cos^2 \phi}$$

$$\therefore \text{L.P.C} = 53.14 \text{ mm}$$

$$\text{L.P.C} = \left(\sqrt{R_a^2 - (R \cos \phi)^2} - R \sin \phi \right) + \left(\sqrt{r_a^2 - (r \cos \phi)^2} - r \sin \phi \right)$$

$$\therefore 53.14 = 2 \left[\sqrt{R_a^2 - (R \cos \phi)^2} \right] - (R+r) \sin \phi \quad (\because R_a = r_a)$$

$$\therefore 53.14 = 2 \left[\sqrt{R_a^2 - (192 \cos 20^\circ)^2} \right] - (192 + 192) \sin 20^\circ$$

$$\therefore 53.14 = 2 \left[\sqrt{R_A^2 - 32551.73} \right] - 131.33$$

$$\therefore \sqrt{R_A^2 - 32551.73} = 92.23 \text{ mm}$$

$$\therefore R_A = 202.63 \text{ mm}$$

No $R_A = R + \text{Addendum}$
w

$$\therefore \text{Addendum} = R_A - R$$

$$\therefore \text{Addendum} = 10.63 \text{ mm}$$

Example 5.5: Two involute gears in mesh have 20° pressure angle. The gear ratio is 3 and the number of teeth on the pinion is 24. The teeth have a module of 6 mm. The pitch line velocity is 1.5 m/s and the addendum equal to one module. Determine the angle of action of pinion (the angle turned by the pinion when one pair of teeth is in the mesh) and the maximum velocity of sliding.

Solution:

Given data

$$\phi = 20^\circ$$

$$G = T/t = 3$$

$$t = 24$$

$$m = 6 \text{ mm}$$

$$V_p = 1.5 \text{ m/s}$$

$$\text{Addendum} = 1 \text{ module}$$

Find:

Angle of action of the pinion = ?

Max. velocity of sliding = ?

$$r = \frac{mt}{2} = \frac{6 \times 24}{2} = 72 \text{ mm}$$

$$(\because T = 24 \times 3 = 72)$$

$$R = \frac{mT}{2} = \frac{6 \times 72}{2} = 216 \text{ mm}$$

$$r_a = r + \text{Add.} = 72 + (1 \times 6) = 78 \text{ mm}$$

$$R_A = R + \text{Add.} = 216 + (1 \times 6) = 222 \text{ mm}$$

Let the length of path of contact $KL = KP + PL$

$$KP = \left(\sqrt{R_A^2 - (R \cos \phi)^2} - R \sin \phi \right)$$

$$= \left(\sqrt{222^2 - (216 \cos 20^\circ)^2} - 216 \sin 20^\circ \right)$$

$$= 16.04 \text{ mm}$$

$$PL = \left(\sqrt{r_A^2 - (r \cos \phi)^2} - r \sin \phi \right)$$

$$= \left(\sqrt{78^2 - (72 \cos 20^\circ)^2} - 72 \sin 20^\circ \right)$$

$$= 14.18 \text{ mm}$$

$$\text{Arcofcontact} = \frac{\text{Pathofcontact}}{\cos \phi}$$

$$= \frac{16.04 + 14.18}{\cos 20^\circ}$$

$$= 32.16 \text{ mm}$$

$$\text{Angle turned through by pinion } (\theta) = \frac{\text{Length of arc of contact} \times 360^\circ}{\text{circumference of pinion}}$$

$$= \frac{32.16 \times 360}{2\pi \times 72}$$

$$= 25.59$$

$$\text{Max. velocity of sliding} = (\omega_p + \omega_g) \times KP$$

$$= \left(\frac{V}{r} + \frac{V}{r} \right) \times KP \quad (\because V = r\omega)$$

$$= \left(\frac{1500}{72} + \frac{1500}{216} \right) \times 16.04$$

$$= 445.6 \text{ mm/sec}$$

Example 5.6: Two involute gears in a mesh have a module of 8mm and pressure angle of 20° . The larger gear has 57 while the pinion has 23 teeth. If the addendum on pinion and gear wheels are equal to one module, Determine

- i. Contact ratio (No. of pairs of teeth in contact)
- ii. Angle of action of pinion and gear wheel

- iii. Ratio of sliding to rolling velocity at the
- Beginning of the contact.
 - Pitch point.
 - End of the contact.

Solution:

Given data

$$\phi = 20^\circ$$

$$m = 8 \text{ mm}$$

$$T = 57$$

$$t = 23$$

$$\text{Addendum} = 1 \text{ module}$$

$$= 8 \text{ mm}$$

Find:

$$1. \text{ Contact ratio} = ?$$

$$2. \text{ Angle of action of pinion and gear} = ?$$

$$3. \text{ Ratio of sliding to rolling velocity at the}$$

$$a. \text{ Beginning of contact}$$

$$b. \text{ Pitch point}$$

$$c. \text{ End of contact}$$

- i. Let the length of path of contact $KL = KP + PL$

$$\begin{aligned} KP &= \left(\sqrt{R_A^2 - (R \cos \phi)^2} - R \sin \phi \right) \\ &= \left(\sqrt{236^2 - (228 \cos 20^\circ)^2} - 228 \sin 20^\circ \right) \\ &= 20.97 \text{ mm} \end{aligned}$$

$$\begin{aligned} PL &= \left(\sqrt{r_A^2 - (r \cos \phi)^2} - r \sin \phi \right) \\ &= \left(\sqrt{100^2 - (92 \cos 20^\circ)^2} - 92 \sin 20^\circ \right) \\ &= 18.79 \text{ mm} \end{aligned}$$

$$\text{Arcofcontact} = \frac{\text{Path of contact}}{\cos \phi}$$

$$= \frac{KP + PL}{\cos \phi}$$

$$= \frac{20.97 + 18.79}{\cos 20^\circ}$$

$$= 42.29 \text{ mm}$$

$$\begin{aligned}\text{Contact ratio} &= \frac{\text{Length of arc of contact}}{P_c} \\ &= \frac{42.21}{\pi m} = 1.68 \quad \text{say } 2\end{aligned}$$

i.

$$\begin{aligned}\text{Angle of action of pinion } (\delta_p) &= \frac{\text{Length of arc of contact} \times 360^\circ}{\text{circumference of pinion}} \\ &= \frac{42.31 \times 360^\circ}{2\pi \times 92} \\ &= 26.34^\circ\end{aligned}$$

$$\begin{aligned}\text{Angle of action of pinion } (\delta_g) &= \frac{\text{Length of arc of contact} \times 360^\circ}{\text{circumference of gear}} \\ &= \frac{42.31 \times 360^\circ}{2\pi \times 228} \\ &= 10.63^\circ\end{aligned}$$

ii. Ratio of sliding to rolling velocity:

a. Beginning of contact

$$\begin{aligned}\frac{\text{Sliding velocity}}{\text{Rolling velocity}} &= \frac{(\omega_p + \omega_g)KP}{\omega_p r} \\ &= \frac{\left(\omega_p + \frac{92}{228} \omega_p \right) \times 20.97}{\omega_p \times 92} \\ &= 0.32\end{aligned}$$

b. Pitch point

$$\begin{aligned} \frac{\text{Sliding velocity}}{\text{Rolling velocity}} &= \frac{(\omega_p + \omega_g)KP}{\omega_p r} \\ &= \frac{(\omega_p + \omega_g) \times 0}{\omega_p r} \\ &= 0 \end{aligned}$$

c. End of contact

$$\begin{aligned} \frac{\text{Sliding velocity}}{\text{Rolling velocity}} &= \frac{(\omega_p + \omega_g)PL}{\omega_p r} \\ &= \frac{\left(\omega_p + \frac{92}{228} \omega_p \right) \times 18.79}{\omega_p \times 92} \\ &= 0.287 \end{aligned}$$

Example 5.7: Two 20° gears have a module pitch of 4 mm. The number of teeth on gears 1 and 2 are 40 and 24 respectively. If the gear 2 rotates at 600 rpm, determine the velocity of sliding when the contact is at the tip of the tooth of gear 2. Take addendum equal to one module. Also, find the maximum velocity of sliding.

Solution:

Given data

$$\phi = 20^\circ$$

$$m = 4 \text{ mm}$$

$$N_p = 600 \text{ rpm}$$

$$T = 40$$

$$t = 24$$

$$\text{Addendum} = 1 \text{ module}$$

$$= 4 \text{ mm}$$

Find:

$$\text{Velocity of sliding} = ?$$

$$\text{Max. velocity of sliding} = ?$$

$$r = \frac{mt}{2} = \frac{4 \times 24}{2} = 48 \text{ mm}$$

$$R = \frac{mT}{2} = \frac{4 \times 40}{2} = 80 \text{ mm}$$

$$r_a = r + \text{Add.} = 48 + (1 \times 4) = 52 \text{ mm}$$

$$R_A = R + \text{Add.} = 80 + (1 \times 4) = 84 \text{ mm}$$

(Note: The tip of driving wheel is in contact with a tooth of driving wheel at the end of engagement. So it is required to find path of recess.)

Path of recess

$$\begin{aligned}
 PL &= \sqrt{r_A^2 - (r \cos \phi)^2} - r \sin \phi \\
 &= \left(\sqrt{52^2 - (48 \cos 20^\circ)^2} - 48 \sin 20^\circ \right) \\
 &= 9.458 \text{ mm}
 \end{aligned}$$

Velocity of sliding

$$\begin{aligned}
 &= (\omega_p + \omega_g) \times PL \\
 &= \frac{2\pi}{60} (600 + 360) \times 9.458 \\
 \left(\begin{array}{l} N_g = \frac{t}{N_p} \Rightarrow N_g = 600 \times \frac{24}{40} = 360 \text{ rpm} \\ \therefore \frac{N_p}{T} = \frac{N_g}{40} \end{array} \right)
 \end{aligned}$$

$$= 956.82 \text{ mm/sec}$$

Path of recess

$$\begin{aligned}
 \therefore KP &= \sqrt{R_A^2 - (R \cos \phi)^2} - R \sin \phi \\
 &= \left(\sqrt{84^2 - (80 \cos 20^\circ)^2} - 80 \sin 20^\circ \right) \\
 &= 10.108 \text{ mm}
 \end{aligned}$$

Max. Velocity of sliding

$$\begin{aligned}
 &= (\omega_p + \omega_g) \times KP \\
 &= \frac{2\pi}{60} (600 + 360) \times 10.108 \\
 &= 1016.16 \text{ mm/sec}
 \end{aligned}$$

Example 5.8: Two 20° involute spur gears mesh externally and give a velocity ratio of 3. The module is 3 mm and the addendum is equal to 1.1 module. If the pinion rotates at the 120 rpm, determine

- I. Minimum no of teeth on each wheel to avoid interference
- II. Contact ratio

Solution:

Given data

$$\phi = 20^\circ$$

$$VR = 3$$

$$m = 3$$

$$N_p = 120$$

$$\text{Addendum} = 1.1 \text{ module}$$

Find:

$$t_{\min} \text{ \& } T_{\min} = ?$$

$$\text{Contact ratio} = ?$$

I.

$$T = \frac{2A_w}{\sqrt{1 + \frac{1}{G} \left(\frac{1}{3} + 2 \right) \sin^2 \phi - 1}}$$

$$\therefore T = \frac{2 \times 1.1}{\sqrt{1 + \frac{1}{3} \left(\frac{1}{3} + 2 \right) \sin^2 20^\circ - 1}}$$

$$\therefore T = 49.44 \text{ teeth}$$

$$\therefore T = 51 \text{ teeth}$$

And

$$t = \frac{T}{3} = \frac{51}{3} = 17 \text{ teeth}$$

II

$$r = \frac{mt}{2} = \frac{3 \times 17}{2} = 25.5 \text{ mm} \quad R = \frac{mT}{2} = \frac{3 \times 51}{2} = 76.5 \text{ mm}$$

$$r_a = r + \text{Add.} = 25.5 + (1.1 \times 3) = 28.8 \text{ mm} \quad R_A = R + \text{Add.} = 76.5 + (1.1 \times 3) = 28.8 \text{ mm}$$

$$\text{Contact ratio} = \frac{\text{Length of path of contact}}{\cos \phi \times P_c}$$

$$= \frac{\left(\sqrt{R_A^2 - (R \cos \phi)^2} - R \sin \phi\right) + \left(\sqrt{r_A^2 - (r \cos \phi)^2} - r \sin \phi\right)}{\cos 20^\circ \times \pi \times 3}$$

$$= \frac{\left(\sqrt{79.8^2 - (76.5 \cos 20^\circ)^2} - 76.5 \sin 20^\circ\right) + \left(\sqrt{28.8^2 - (25.5 \cos 20^\circ)^2} - 25.5 \sin 20^\circ\right)}{\cos 20^\circ \times \pi \times 3}$$

$$= 1.78$$

Thus 1 pair of teeth will always remain in contact whereas for 78 % of the time, 2 pairs of teeth will be in contact.

Example 5.9: Two involute gears in a mesh have a velocity ratio of 3. The arc of approach is not to be less than the circular pitch when the pinion is the driver. The pressure angle of the involute teeth is 20° . Determine the least no of teeth on the each gear. Also find the addendum of the wheel in terms of module.

Solution:

Given data

$$\phi = 20^\circ$$

$$VR = 3$$

Find:

least no of teeth on the each gear = ?

Addendum = ?

Arc of approach = circular pitch

$$= \pi \cdot m$$

\therefore Path of approach = Arc of approach $\times \cos 20^\circ$

$$= \pi \cdot m \cdot \cos 20^\circ$$

$$= 2.952m \quad \dots\dots\dots(1)$$

Let the max length of path of approach = $r \sin \phi$

$$= \frac{mt}{2} \sin 20^\circ$$

$$= 0.171mt \quad \dots\dots\dots(2)$$

From eq. 1. And 2.

$$\therefore 0.171mt = 2.952m$$

$$\therefore t = 17.26 \cong 18 \text{ teeth}$$

$$T = 18 \times 3 = 54 \text{teeth}$$

Max. Addendum of the wheel

$$\begin{aligned} A_{w\max} &= \frac{mt}{2} \left[\sqrt{1 + \frac{1}{G(G+2)} \sin^2 \phi} - 1 \right] \\ &= \frac{m \times 54}{2} \left[\sqrt{1 + \frac{1}{3(3+2)} \sin^2 20^\circ} - 1 \right] \\ &= 1.2m \end{aligned}$$

Example 5.10: Two 20° involute spur gears have a module of 10 mm. The addendum is equal to one module. The larger gear has 40 teeth while the pinion has 20 teeth will the gear interfere with the pinion?

Solution:

Given data

$$\phi = 20^\circ$$

$$m = 10 \text{ mm}$$

Addendum = 1 module

$$= 1 \times 10$$

$$= 10 \text{ mm}$$

Find:

Interference or not?

Let the pinion is the driver

$$t = 20 \text{ teeth}$$

$$T = 40 \text{ teeth}$$

$$r = \frac{mt}{2} = \frac{10 \times 20}{2} = 100 \text{ mm}$$

$$R = \frac{mT}{2} = \frac{10 \times 40}{2} = 200 \text{ mm}$$

$$r_a = r + \text{Add.} = 100 + 10 = 110 \text{ mm} \quad R_A = R + \text{Add.} = 200 + 10 = 210 \text{ mm}$$

$$\begin{aligned} \text{Path of approach} &= \left(\sqrt{R_A^2 - (r \sin \phi)^2} - R \sin \phi \right) \\ &= \left(\sqrt{210^2 - (100 \sin 20^\circ)^2} - 200 \sin 20^\circ \right) \\ &= 25.29 \text{ mm} \end{aligned}$$

To avoid the interference.....

$$\begin{aligned} \text{Max length of path of approach} &= r \sin \phi \\ &= 100 \times \sin 20^\circ \\ &= 34.20 \text{ mm} > 25.29 \text{ mm} \end{aligned}$$

So Interference will **not occur**.

Example 5.11: Two 20° involute spur gears have a module of 10 mm. The addendum is one module. The larger gear has 50 teeth and the pinion has 13 teeth. Does interference occur? If it occurs, to what value should the pressure angle be change to eliminate interference?

Solution:

Given data

$$\begin{aligned} \phi &= 20^\circ \\ m &= 10 \text{ mm} \\ \text{Addendum} &= 1 \text{ module} = 10 \text{ mm} \\ T &= 50 \quad \text{and} \quad t = 13 \end{aligned}$$

$$r = \frac{mt}{2} = \frac{10 \times 13}{2} = 65 \text{ mm} \qquad R = \frac{mT}{2} = \frac{10 \times 50}{2} = 250 \text{ mm}$$

$$r_a = r + \text{Add.} = 65 + 10 = 75 \text{ mm} \quad R_a = R + \text{Add.} = 250 + 10 = 260 \text{ mm}$$

$$\begin{aligned} R_{a \max} &= \sqrt{(R \cos \phi)^2 + (R \sin \phi + r \sin \phi)^2} \\ &= \sqrt{(250 \cos 20^\circ)^2 + (250 \sin 20^\circ + 65 \sin 20^\circ)^2} \\ &= 258.45 \text{ mm} \end{aligned}$$

Here actual addendum radius R_a (260 mm) $>$ $R_{a \max}$ value

So interference will

occur. The new value of ϕ can be found by

comparing

$$R_{a \max} = R_a$$

$$\therefore R_a = R_{a \max}$$

$$\therefore R_a = \sqrt{(R \cos \phi)^2 + (R \sin \phi + r \sin \phi)^2}$$

$$\therefore 260 = \sqrt{(250 \cos \phi)^2 + (250 \sin \phi + 65 \sin \phi)^2}$$

$$\therefore 260^2 = (250 \cos \phi)^2 + (250 \sin \phi + 65 \sin \phi)^2$$

$$\therefore \cos^2 \phi = 0.861$$

$$\therefore \phi = 21.88^\circ$$

Note: If pressure angle is increased to 21.88° interference can be avoided

Example 5.12: The following data related to meshing involute gears:

No. of teeth on gear wheel = 60

Pressure angle = 20°

Gear ratio = 1.5

Speed of gear wheel = 100 rpm

Module = 8 mm

The addendum on each wheel is such that the path of approach and path of recess on each side are 40 % of the maximum possible length each. Determine the addendum for the pinion and the gear and the length of arc of contact.

Solution:

Given data

$$T = 60$$

$$\phi = 20^\circ$$

$$G = 1.5$$

$$N_g = 100$$

$$\text{rpm } m = 8$$

$$\text{mm}$$

Find:

Addendum for gear and pinion=?

Length of arc of contact=?

Let pinion is driver...

Max. Possible length of path of approach = $r \sin \phi$

\therefore Actual length of path of approach = $0.4 r \sin \phi$ (Given in data)

Same way...

Actual length of path of recess = $0.4 R \sin \phi$ (Given in data)

$$\therefore 0.4 r \sin \phi = \left(\sqrt{R^2 - (R \cos \phi)^2} - R \sin \phi \right)$$

$$\therefore 0.4 \times 160 \sin 20 = \left(\sqrt{R_a^2 - (240 \cos 20)^2} - 240 \sin 20 \right)$$

$$\therefore R_a = 248.33 \text{ mm}$$

$$\therefore \text{Addendum of wheel} = 248.3 - 240 = 8.3 \text{ mm}$$

Also

$$0.4 R \sin \phi = \sqrt{r_a^2 - (r \cos \phi)^2} - r \sin \phi$$

$$\therefore 0.4 \times 240 \times \sin 20 = \sqrt{r_a^2 - (160 \cos 20)^2} - 160 \sin 20$$

$$\therefore r_a = 173.98 = 174 \text{ mm}$$

$$\therefore \text{Addendum of pinion} = 174 - 160 = 14 \text{ mm}$$

$$\begin{aligned} \text{Length of Arc of contact} &= \frac{\text{Path of contact}}{\cos \phi} \\ &= \frac{(r \sin \phi + R \sin \phi) \times 0.4}{\cos \phi} \\ &= \frac{(160 + 240) \times \sin 20 \times 0.4}{\cos 20} \\ &= 58.2 \text{ mm} \end{aligned}$$

Example 5.13: A pinion of 20° involute teeth rotating at 274 rpm meshes with a gear and provides a gear ratio of 1.8. The no. of teeth on the pinion is 20 and the module is 8mm .If interference is just avoided

- Determine:
1. Addendum on wheel and pinion
 2. Path of contact
 3. Max. Velocity of sliding on both side of pitch point

Solution:

Given data

$$\begin{aligned}\phi &= 20^\circ \\ m &= 8 \text{ mm} \\ N_p &= 275 \text{ rpm} \\ T &= 36 \\ t &= 20\end{aligned}$$

Find:

1. Addendum on wheel and pinion = ?
2. Path of contact = ?
3. Max. velocity of sliding on both side of pitchpoint = ?

Max. Addendum on wheel

$$\begin{aligned}\therefore A_{w \max} &= R \left[\sqrt{1 + \frac{1}{G} \left(\frac{1}{G} + 2 \right) \sin^2 \phi} - 1 \right] \\ \therefore A_{w \max} &= 144 \left[\sqrt{1 + \frac{1}{1.8} \left(\frac{1}{1.8} + 2 \right) \sin^2 20} - 1 \right] \\ &= 11.5 \text{ mm}\end{aligned}$$

Max. Addendum on pinion

$$\begin{aligned}\therefore A_{p \max} &= r \left[\sqrt{1 + G(G+2) \sin^2 \phi} - 1 \right] \\ \therefore A_{p \max} &= 80 \left[\sqrt{1 + 1.8(1.8+2) \sin^2 20} - 1 \right] \\ &= 27.34 \text{ mm}\end{aligned}$$

Path of contact when interference is just avoided

$$\begin{aligned}&= \text{Max. path of approach} + \text{Max. path of recess} \\ &= r \sin \phi + R \sin \phi \\ &= 80 \sin 20 + 144 \sin 20 \\ &= 27.36 + 49.25 \\ &= 76.6 \text{ mm}\end{aligned}$$

Velocity of sliding ononesideof approach

$$= (\omega_p + \omega_g) \text{Path of approach}$$

$$\left(\begin{array}{l} \omega = \frac{2\pi \times 275}{60} = 28.8 \text{ rad / sec} \\ \omega = \frac{28.8}{1.8 - G} = 16 \text{ rad / sec} \end{array} \right)$$

$$= (28.8 + 16) \times 27.36$$

$$= 1225.72 \text{ mm / sec}$$

Velocity of sliding on side of path of recess

$$= (\omega_p + \omega_g) \text{Path of recess}$$

$$= (28.8 + 16) \times 49.25$$

$$= 2206 \text{ mm / sec}$$

Example 5.14: A pinion of 20 involute teeth and 125 mm pitch circle diameter drives a rack. The addendum of both pinion and rack is 6.25 mm. What is the least pressure angle which can be used to avoid interference? With this pressure angle, find the length of the arc of contact and the minimum number of teeth in contact at a time.

Solution:

Given data

$$T = 20$$

$$d = 125 \text{ mm}$$

$$r = OP = 62.5 \text{ mm}$$

Addendum for rack / pinion, LH = 6.25 mm

Find:

1. Least pressure angle to avoid interference = ?

2. Length of arc of contact = ?

3. Min. no. of teeth in contact = ?

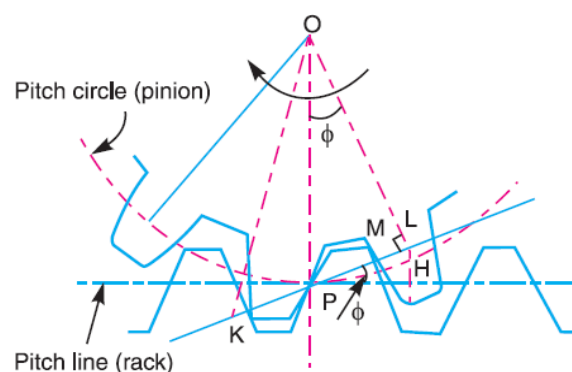

Least pressure angle to avoid interference

Let ϕ = Least pressure angle to avoid interference.

We know that for no interference, rack addendum,

$$\begin{aligned} \text{From fig.....} \quad LH &= PL \sin \phi \\ &= r \sin \phi \times \sin \phi \\ &= r \sin^2 \phi \\ \therefore \sin^2 \phi &= \frac{LH}{r} = \frac{6.25}{62.5} \\ \therefore \phi &= (18.4349)^\circ \end{aligned}$$

Length of arc of contact

$$\begin{aligned} \text{Now,} \quad KL &= \sqrt{OK^2 -} \\ &= \sqrt{(OP + 6.25)^2 - (r \cos \phi)^2} \\ &= \sqrt{(62.5 + 6.25)^2 - (62.5 \times \cos 18.439^\circ)^2} \\ &= 34.8 \text{ mm} \end{aligned}$$

$$\text{Length of Arc of Contact} = \frac{KL}{\cos \phi} = \frac{34.8}{\cos 18.439^\circ} = 36.68 \text{ mm}$$

Min. No. of teeth in contact

$$\begin{aligned} \text{Min. no. of teeth in contact} &= \frac{\text{Length of arc of contact}}{p_c} \\ &= \frac{\text{Length of arc of contact}}{\pi \cdot m} \\ &= \frac{36.68}{19.64} \\ &= 1.87 \\ &\cong 2 \end{aligned}$$

Example 5.15: In a spiral gear drive connecting two shafts, the approximate center distance is 400 mm and the speed ratio = 3. The angle between the two shafts is 50° and the normal pitch is 18 mm. The spiral angles for the driving and driven wheels are equal.

- Find :
1. Number of teeth on each wheel,
 2. Exact center distance, and
 3. Efficiency of the drive, if friction angle = 6° .
 4. Maximum efficiency.

Solution:

Given data:

$$L = 400 \text{ mm} \quad \theta = 50^\circ \quad G = \frac{T_2}{T_1} = 3$$

$$\phi = 6 \quad P_N = 18 \text{ mm}$$

1. No. of teeth on wheel:

$$L = \frac{P \cdot T}{2\pi} \left[\frac{1}{\cos\alpha_1} + \frac{G}{\cos\alpha_2} \right]$$

$$\therefore 400 = \frac{P_N \cdot T_1}{2\pi} \times \frac{1+G}{\cos\alpha_1}$$

$$\therefore 400 = \frac{18 \cdot T_1}{2\pi} \times \frac{1+3}{\cos 25^\circ}$$

$$\therefore T_1 = 31.64 \square 32$$

$$\therefore T_2 = 3T_1 = 96$$

$$\left(\begin{array}{l} \therefore \alpha_1 = \alpha_2 \\ \theta = \alpha_1 + \alpha_2 \\ \therefore 50 = 2\alpha_1 \\ \therefore \alpha_1 = 25^\circ \end{array} \right)$$

2. Exact center distance (L):

$$L = \frac{P \cdot T}{2\pi} \left[\frac{1}{\cos\alpha_1} + \frac{G}{\cos\alpha_2} \right]$$

$$= \frac{P \cdot T}{2\pi} \left[\frac{1+G}{\cos\alpha_1} \right] \quad (\because \alpha_1 = \alpha_2)$$

$$= \frac{18 \cdot 32}{2\pi} \left[\frac{1+3}{\cos 25^\circ} \right]$$

$$= 404.600 \text{ mm}$$

3. Efficiency of drive:

$$\eta = \frac{\cos(\alpha_2 + \phi) \times \cos\alpha_1}{\cos(\alpha_1 - \phi) \times \cos\alpha_2}$$

$$= \frac{\cos(\alpha_1 + \phi)}{\cos(\alpha_1 - \phi)} \quad (\because \alpha_1 = \alpha_2)$$

$$= \frac{\cos(25+6)}{\cos(25-6)}$$

$$= 90.655 \%$$

4. Maximum efficiency:

$$\begin{aligned}\eta_{\max} &= \frac{\cos(\theta + \phi) + 1}{\cos(\theta - \phi) + 1} \\ &= \frac{\cos(50 + 6) + 1}{\cos(50 - 6) + 1} \\ &= 90.685 \%\end{aligned}$$

Example 5.16: A drive on a machine tool is to be made by two spiral gear wheels, the spirals of which are of the same hand and has normal pitch of 12.5 mm. The wheels are of equal diameter and the center distance between the axes of the shafts is approximately 134 mm. The angle between the shafts is 80° and the speed ratio 1.25.

Determine : 1. the spiral angle of each wheel,

2. The number of teeth on each wheel,

3. The efficiency of the drive, if the friction angle is 6° , and

4. The maximum efficiency.

Solution:

Given data:

$$P_N = 12.5 \text{ mm}$$

$$L = 134 \text{ mm}$$

$$G = 1.25$$

$$\theta = 80^\circ$$

1. Spiral angle of each wheel

We know that.....

$$\therefore \frac{d_2}{d_1} = \frac{T_2 \cos \alpha_1}{T_1 \cos \alpha_2}$$

$$\therefore T_1 \cos \alpha_2 = T_2 \cos \alpha_1 \quad (\because d_1 = d_2)$$

$$\therefore \cos \alpha_1 = 1.25 \cos \alpha_2 \quad (\because \frac{T_1}{1.25} = G = T_2)$$

$$\therefore \cos \alpha_1 = 1.25 \cos(\theta - \alpha_1) \quad (\because \alpha_1 + \alpha_2 = \theta)$$

$$\therefore \cos \alpha_1 = 1.25 \cos(80 - \alpha_1)$$

)

$$\therefore \cos \alpha_1 = 1.25 (\cos 80 \cdot \cos \alpha_1 + \sin 80 \cdot \sin \alpha_1)$$

$$(\because \cos(A - B) = \cos A \cdot \cos B + \sin A \cdot \sin B)$$

By solving.....

$$\tan\alpha_1 = 0.636$$

$$\therefore \alpha_1 = 32.46^\circ$$

and $\alpha_2 = 80^\circ - 32.46^\circ = 47.54^\circ$

2. No. of teeth on wheel:

$$L = \frac{d_1 + d_2}{2}$$

$$\therefore 134 = \frac{2d_1}{2} \quad (\because d_1 = d_2)$$

$$\therefore d_1 = 134 \text{ mm}$$

$$\text{Let } p_{c1} = \frac{\pi d_1}{T_1} \Rightarrow d_1 = \frac{p_{c1} \cdot T_1}{\pi}$$

$$\therefore d_1 = \frac{P_N}{\cos\alpha_1} \times \frac{T_1}{\pi}$$

$$\therefore T_1 = \frac{d_1 \cdot \cos\alpha_1 \cdot \pi}{P_N}$$

$$\therefore T_1 = \frac{134 \times \cos 32.24 \times \pi}{12.5}$$

$$\therefore T_1 = 28.4 \approx 30 \text{ nos.}$$

$$\text{Now, } G \equiv \frac{T_1}{T_2} = 1.25 \quad T_2 = \frac{T_1}{G} = \frac{30}{1.25}$$

$$\Rightarrow T_2 = 24 \text{ nos.}$$

3. Efficiency of drive:

$$\eta = \frac{\cos(\alpha_2 + \phi) \times \cos\alpha_1}{\cos(\alpha_1 - \phi) \times \cos\alpha_2}$$

$$= \frac{\cos(47.24 + 6) \times \cos 32.46}{\cos(32.46 - 6) \times \cos 47.24}$$

$$= 83 \%$$

4. Maximum efficiency:

$$\eta_{\max} = \frac{\cos(\theta + \phi) + 1}{\cos(\theta - \phi) + 1}$$

$$= \frac{\cos(80 + 6) + 1}{\cos(80 - 6) + 1}$$

$$= 83.8 \%$$

Example 5.17: Find the minimum no. of teeth on gear wheel and the arc of contact(in term of module) to avoid the interference in the following cases:

- I. The gear ratio is unity
- II. The gear ratio is 3
- III. Pinion gear with a rack

Addendum of the teeth is 0.84 module and the power component is 0.95 times the normal thrust.

Solution:

$$\begin{aligned} \text{Here } A_w &= 0.84 \\ \cos\phi &= 0.95 \Rightarrow \phi = 18.19 \\ \therefore \sin\phi &= 0.3122 \end{aligned}$$

I. Gear ratio is unity

- Let min. no of teeth on gear wheel T

$$\begin{aligned} \therefore T &= \left[\frac{2A_w}{\sqrt{1 + \frac{1}{G} \left(\frac{1}{G} + 2 \right) \sin^2 \phi} - 1} \right] \\ &= \left[\frac{2A_w \cdot G}{\sqrt{G^2 + (1 + 2G) \sin^2 \phi} - G} \right] \\ &= \left[\frac{2 \times 0.84 \times 1}{\sqrt{1^2 + (1 + 2)(0.3122)^2} - 1} \right] \\ &= 12.73 \\ \therefore T &\cong 13 \text{ teeth} \\ \therefore t &\cong 13 \text{ teeth} \end{aligned}$$

- Length of arc of contact:

$$\begin{aligned} \text{L.P.C} &= \left(\sqrt{R_A^2 - (R \cos \phi)^2} - R \sin \phi \right) + \left(\sqrt{r_A^2 - (r \cos \phi)^2} - r \sin \phi \right) \\ &= 2 \left(\sqrt{r^2 - (r \cos \phi)^2} - r \sin \phi \right) \quad \left\{ \begin{array}{l} \because r = \frac{m \cdot t}{2} = \frac{m \cdot 13}{2} = 6.5m \\ r = r + \text{addendum} \\ = 6.5m + 0.84m \\ = 7.34m \end{array} \right. \\ &= 2m \left(\sqrt{(7.34)^2 - (6.5 \times 0.95)^2} - (6.5 \times 0.3122) \right) \\ &= 3.876m \end{aligned}$$

$$\text{L.A.C} = \frac{3.876\text{m}}{\cos \phi} = \frac{3.876\text{m}}{0.95}$$

$$\therefore \text{L.A.C} = 4.08\text{m}$$

II. Gear ratio $G = 3$

- Let min. no of teeth on gear wheel T

$$\begin{aligned} \therefore T &= \left[\frac{2A_w}{\sqrt{1 + \frac{1}{G} \left(\frac{1}{G} + 2 \right) \sin^2 \phi} - 1} \right] \\ &= \left[\frac{2A_w \cdot G}{\sqrt{G^2 + (1 + 2G) \sin^2 \phi} - G} \right] \\ &= \left[\frac{2 \times 0.84 \times 3}{\sqrt{3^2 + (1 + 2 \times 3)(0.3123)^2} - 3} \right] \\ &= 45.11 \end{aligned}$$

$$\therefore T \cong 45 \text{ teeth}$$

$$\therefore t \cong 15 \text{ teeth}$$

- Length of arc of contact:

$$\text{L.P.C} = \left(\sqrt{R_A^2 - (R \cos \phi)^2} - R \sin \phi \right) + \left(\sqrt{r_A^2 - (r \cos \phi)^2} - r \sin \phi \right) \dots \dots \dots (1)$$

$$\left(\begin{array}{l} m \cdot t \quad m \cdot 15 \\ \therefore r = \frac{\quad}{2} = \frac{\quad}{2} = 7.5m \\ r_A = r + \text{addendum} \\ \quad = 7.5m + 0.84m \\ \quad = 8.34m \\ R = \frac{mT}{2} = \frac{m \times 45}{2} = 22.5m \\ R_A = R + \text{addendum} \\ \quad = 22.5m + 0.84m \\ \quad = 23.34m \end{array} \right)$$

putting all values in equation (1)

$$= \left(\sqrt{(23.34\text{m})^2 - (22.5\text{m} \times 0.95)^2} - 22.5\text{m} \times 0.3122 \right) + \left(\sqrt{(8.34\text{m})^2 - (7.5\text{m} \times 0.95)^2} - 7.5\text{m} \times 0.3122 \right)$$

$$= 4.343\text{m}$$

$$\text{L.A.C} = \frac{4.343\text{m}}{\cos \phi} = \frac{3.876\text{m}}{0.95}$$

$$\therefore \text{L.A.C} = 4.57\text{m}$$

III. Pinion gear with a rack

- Min. no. of teeth on pinion t

$$t = \frac{2 A_R}{\sin^2 \phi} = \frac{2 \times 0.84}{(0.3123)^2}$$

$$\therefore t = 17.23$$

$$\therefore t \cong 18$$

- Length of arc of contact:

$$\text{L.P.C} = \left(\sqrt{R_A^2 - (R \cos \phi)^2} - R \sin \phi \right) + \left(\sqrt{r_A^2 - (r \cos \phi)^2} - r \sin \phi \right)$$

$$= 2 \left(\sqrt{r_A^2 - (r \cos \phi)^2} - r \sin \phi \right) \quad (\text{:assume rack and pinion same dimension})$$

$$= 2 \left(\sqrt{(9.84)^2 - (9\text{m} \times 0.95)^2} - 9\text{m} \times 0.3123 \right)$$

$$= 4.12\text{m}$$

$$\left. \begin{array}{l} \therefore r = \frac{mt}{2} = \frac{18\text{m}}{2} = 9\text{m} \\ r = r + \text{addendum} \\ = 9\text{m} + 0.84\text{m} \\ = 9.84\text{m} \end{array} \right\}$$

$$\text{L.A.C} = \frac{4.12\text{m}}{\cos \phi} = \frac{4.12\text{m}}{0.95}$$

$$\therefore \text{L.A.C} = 4.337\text{m}$$

Gear Train

Introduction

Definition

- When two or more gears are made to mesh with each other to transmit power from one shaft to another. Such a combination is called gear train or train of toothed wheels.
- The nature of the train used depends upon the velocity ratio required and the relative position of the axes of shafts. A gear train may consist of spur, bevel or spiral gears.

Types of Gear Trains

1. Simple gear train
2. Compound gear train
3. Reverted gear train
4. Epicyclic gear train
5. Compound epicyclic gear train

Simple gear train.

- When there is only one gear on each shaft, as shown in Fig. , it is known as **simple gear train**. The gears are represented by their pitch circles.
- When the distance between the two shafts is small, the two gears 1 and 2 are made to mesh with each other to transmit motion from one shaft to the other, as shown in Fig.
- Since the gear 1 drives the gear 2, therefore gear 1 is called the **driver** and the gear 2 is called the **driven** or **follower**. It may be noted that the motion of the driven gear is opposite to the motion of driving gear.

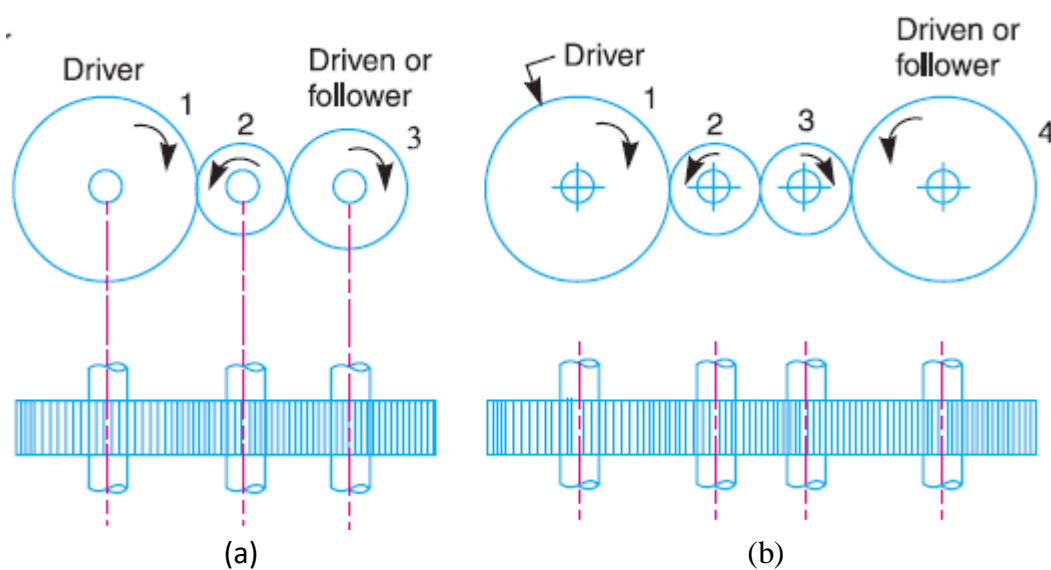

Fig.5.2.1 Simple gear train

Let

N_1 = Speed of driver rpm

N_2 = Speed of intermediate wheel rpm

N_3 = Speed of follower rpm

T_1 = Number of teeth on driver

T_2 = Number of teeth on intermediate wheel T_3

= Number of teeth on follower

- Since the driving gear 1 is in mesh with the intermediate gear 2, therefore speed ratio for these two gears is

$$\frac{N_1}{N_2} = \frac{T_2}{T_1} \quad \dots\dots\dots(1)$$

- Similarly, as the intermediate gear 2 is in mesh with the driven gear 3, therefore speed ratio for these two gears is

$$\frac{N_2}{N_3} = \frac{T_3}{T_2} \quad \dots\dots\dots(2)$$

- The speed ratio of the gear train as shown in Fig. (a) is obtained by multiplying the equations (1) and (2).

$$\begin{aligned} \frac{N_1}{N_2} \times \frac{N_2}{N_3} &= \frac{T_2}{T_1} \times \frac{T_3}{T_2} \\ \therefore \frac{N_1}{N_3} &= \frac{T_3}{T_1} \end{aligned}$$

- Sometimes, the distance between the two gears is large. The motion from one gear to another, in such a case, may be transmitted by either of the following two methods:
 1. By providing the large sized gear, or
 - A little consideration will show that this method (i.e. providing large sized gears) is very inconvenient and uneconomical method.
 2. By providing one or more intermediate gears.
 - This method (i.e. providing one or more intermediate gear) is very convenient and economical.
 - It may be noted that when the number of intermediate gears are **odd**, the motion of both the gears (i.e. driver and driven or follower) is like as shown in Fig. (a).
 - If the numbers of intermediate gears are **even**, the motion of the driven or follower will be in the **opposite direction** of the driver as shown in Fig (b).
-

- **speed ratio** (or velocity ratio) of gear train is the ratio of the speed of the driver to the speed of the driven or follower and ratio of speeds of any pair of gears in mesh is the inverse of their number of teeth.

$$\text{Speedratio} = \frac{N_1}{N_2} = \frac{T_2}{T_1}$$

- **Train value** of the gear train is the ratio of the speed of the driven or follower to the speed of the driver.

$$\text{Trainvalue} = \frac{N_2}{N_1} = \frac{T_1}{T_2}$$

Compound Gear Train

- When there is more than one gear on a shaft, as shown in Fig., it is called a **compound train of gear**.
- The idle gears, in a simple train of gears do not affect the speed ratio of the system. But these gears are useful in bridging over the space between the driver and the driven.
- But whenever the distance between the driver and the driven or follower has to be bridged over by intermediate gears and at the same time a great (or much less) speed ratio is required, then the advantage of intermediate gears is intensified by providing compound gears on intermediate shafts.
- In this case, each intermediate shaft has two gears rigidly fixed to it so that they may have the same speed. One of these two gears meshes with the driver and the other with the driven or follower attached to the next shaft as shown in Fig.

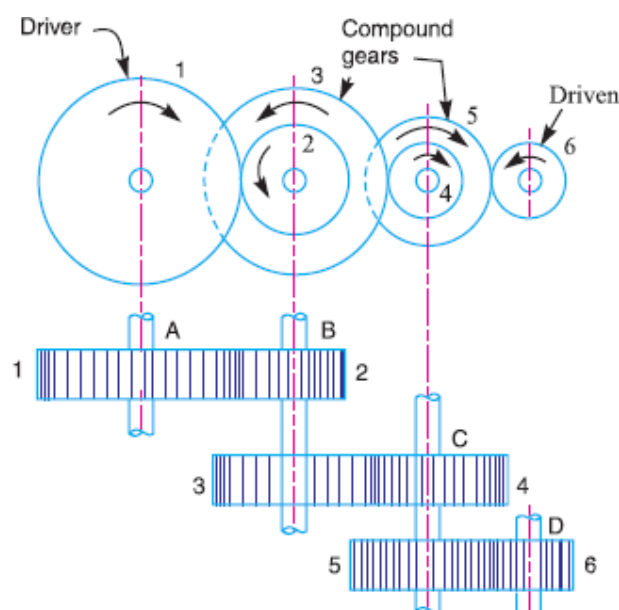

Fig. 5.2.2 compound gear train

- In a compound train of gears, as shown in Fig., the gear 1 is the driving gear mounted on shaft A; gears 2 and 3 are compound gears which are mounted on shaft B. The gears 4 and 5 are also compound gears which are mounted on shaft C and the gear 6 is the driven gear mounted on shaft D.

Let

N_1 = Speed of driving gear 1,

T_1 = Number of teeth on driving gear 1,

$N_2, N_3 \dots, N_6$ = Speed of respective gears in r.p.m.,

and $T_2, T_3 \dots, T_6$ = Number of teeth on respective gears.

Since gear 1 is in mesh with gear 2, therefore its speed ratio is

$$\frac{N_1}{N_2} = \frac{T_2}{T_1} \quad \dots\dots\dots(1)$$

Similarly, for gears 3 and 4, speed ratio is

$$\frac{N_3}{N_4} = \frac{T_4}{T_3} \quad \dots\dots\dots(2)$$

And for gears 5 and 6, speed ratio is

$$\frac{N_5}{N_6} = \frac{T_6}{T_5} \quad \dots\dots\dots(3)$$

The speed ratio of compound gear train is obtained by multiplying the equations (1), (2) and (3),

$$\frac{N_1}{N_2} \times \frac{N_3}{N_4} \times \frac{N_5}{N_6} = \frac{T_2}{T_1} \times \frac{T_4}{T_3} \times \frac{T_6}{T_5}$$

- The **advantage** of a compound train over a simple gear train is that a much larger speed reduction from the first shaft to the last shaft can be obtained with small gears.
 - If a simple gear train is used to give a large speed reduction, the last gear has to be very large.
 - Usually for a speed reduction in excess of 7 to 1, a simple train is not used and a compound train or worm gearing is employed.
-

Reverted Gear Train

- When the axes of the first gear (i.e. first driver) and the last gear (i.e. last driven or follower) are co-axial, then the gear train is known as **reverted gear train**.
- Gear 1 (i.e. first driver) drives the gear 2 (i.e. first driven or follower) in the opposite direction. Since the gears 2 and 3 are mounted on the same shaft, therefore they form a compound gear and the gear 3 will rotate in the same direction as that of gear 2. The gear 3 (which is now the second driver) drives the gear 4 (i.e. the last driven or follower) in the same direction as that of gear 1. Thus we see that in a reverted gear train, the motion of the first gear and the last gear is **like**.

Let

T_1 = Number of teeth on gear 1,

r_1 = Pitch circle radius of gear 1, and

N_1 = Speed of gear 1 in r.p.m.

T_2

=

Similarly,

T_3 , T_4 = Number of teeth on respective gears,

r_2

r_3 , r_4 = Pitch circle radii of respective gears, and

N_2 , N_3 , N_4 = Speed of respective gears in r.p.m.

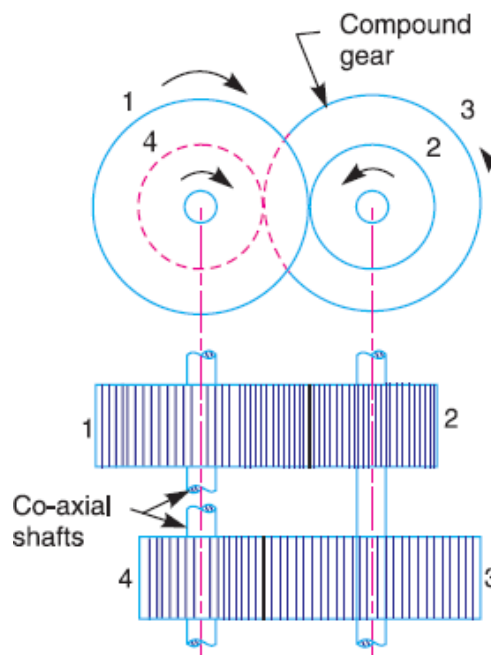

Fig. 5.2.3 Reverted gear train

- Since the distance between the centers of the shafts of gears 1 and 2 as well as gears 3 and 4 is same, therefore

$$r_1 + r_2 = r_3 + r_4$$

- Also, the circular pitch or module of all the gears is assumed to be same; therefore number of teeth on each gear is directly proportional to its circumference or radius.

$$T_1 + T_2 = T_3 + T_4$$

$$\text{Speedratio} = \frac{\text{Product of number of teeth on drivers}}{\text{Product of number of teeth on driven}}$$

$$\frac{N_1}{N_4} = \frac{T_2 \times T_4}{T_1 \times T_3}$$

Application

- The reverted gear trains are used in automotive transmissions, lathe back gears, industrial speed reducers, and in clocks (where the minute and hour hand shafts are co-axial).

Epicyclic Gear Train

- In an epicyclic gear train, the axes of the shafts, over which the gears are mounted, may move relative to a fixed axis. A simple epicyclic gear train is shown in Fig. where a gear A and the arm C have a common axis at O₁ about which they can rotate. The gear B meshes with gear A and has its axis on the arm at O₂, about which the gear B can rotate.
- If the arm is fixed, the gear train is simple and gear A can drive gear B or **vice-versa**, but if gear A is fixed and the arm is rotated about the axis of gear A (i.e. O₁), then the gear B is forced to rotate **upon** and **around** gear A. Such a motion is called **epicyclic** and the gear trains arranged in such a manner that one or more of their members move upon and around another member is known as **epicyclic gear trains** (**epi.** means upon and **cylic** means around). The epicyclic gear trains may be **simple** or **compound**.

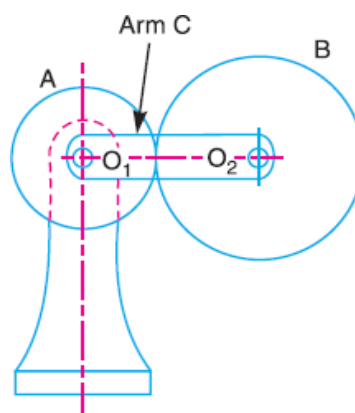

Fig. 5.2.4 Epicyclic gear train

Sr. No.	Condition of motion	Revolution of element		
		Arm C	Gear A	Gear B
1	Arm fixe, gear A rotates +1 revolution(anticlockwise)	0	+1	$-\frac{T_A}{T_B}$
2	Arm fixed gear A rotates through + x revolutions	0	+x	$-x \frac{T_A}{T_B}$
3	Add + y revolutions to all elements	+ y	+ y	+ y
4	Total motion	+ y	x + y	$y - x \frac{T_A}{T_B}$

Application

- The epicyclic gear trains are useful for transmitting high velocity ratios with gears of moderate size in a comparatively lesser space. The epicyclic gear trains are used in the back gear of lathe, differential gears of the automobiles, hoists, pulley blocks, wrist watches etc.

Compound Epicyclic Gear Train—Sun and Planet Gear

- A compound epicyclic gear train is shown in Fig. It consists of two co-axial shafts S1 and S2, an annulus gear A which is fixed, the compound gear (or planet gear) B-C, the sun gear D and the arm H. The annulus gear has internal teeth and the compound gear is carried by the arm and revolves freely on a pin of the arm H. The sun gear is co-axial with the annulus gear and the arm but independent of them.
- The annulus gear A meshes with the gear B and the sun gear D meshes with the gear C. It may be noted that when the annulus gear is fixed, the sun gear provides the drive and when the sun gear is fixed, the annulus gear provides the drive. In both cases, the arm acts as a follower.

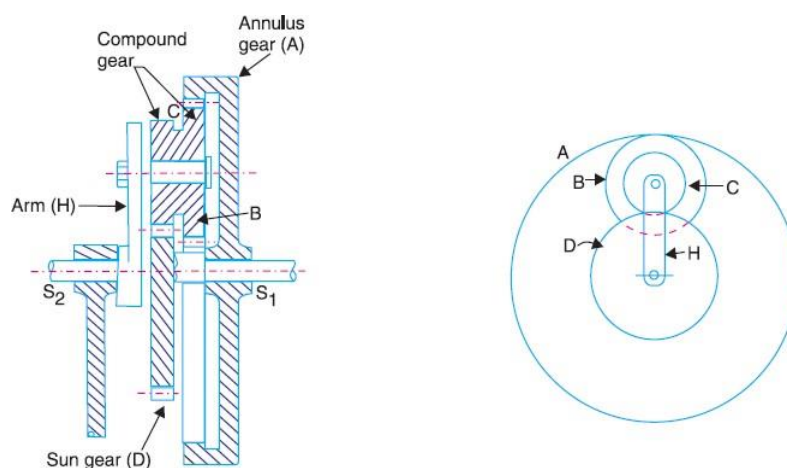

Fig. 5.2.5 Compound epicyclic gear train.

Note: The gear at the center is called the **sun gear** and the gears whose axes move are called **planet gears**.

Let T_A , T_B , T_C , and T_D be the teeth and N_A , N_B , N_C and N_D be the speeds for the gears A, B, C and D respectively. A little consideration will show that when the arm is fixed and the sun gear D is turned anticlockwise, then the compound gear B-C and the annulus gear A will rotate in the clockwise direction.

The motion of rotations of the various elements is shown in the table below.

Table of motions

Sr. No.	Condition of motion	Revolution of motion			
		Ar m	Gear D	Compound Gear (B-C)	Gear A
1	Arm fixe, gear D rotates +1 revolution(anticlockwise)	0	+1	$-\frac{T_D}{T_C}$	$-\frac{T_D}{T_B} \times \frac{T_C}{T_A}$
2	Arm fixed gear D rotates through + x revolutions	0	+x	$\frac{x T_D}{T_C}$	$-\frac{x T_D}{T_B} \times \frac{T_C}{T_A}$
3	Add + y revolutions to all elements	+y	+y	+y	+y
4	Total motion	+y	x + y	$y - x \frac{T_D}{T_C}$	$y - x \frac{T_D}{T_B} \times \frac{T_C}{T_A}$

EXAMPLES

Example 5.1. The gearing of a machine tool is shown in Fig.2.1. The motor shaft is connected to gear A and rotates at 975 rpm. The gear wheels B, C, D and E are fixed to parallel shafts rotating together. The final gear F is fixed on the output shaft. What is the speed of gear F? The number of teeth on each gear is as given below:

Gear	A	B	C	D	E	F
No. of teeth	20	50	25	75	26	65

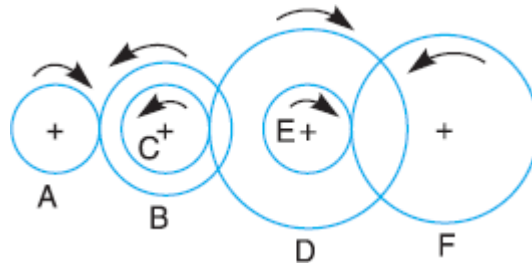

Fig. 6.1

Solution:

Given data

$$\begin{aligned}
 T_A &= 20 & N_F &=? \\
 T_B &= 50 \\
 T_C &= 25 \\
 T_D &= 75 \\
 T_E &= 26 \\
 T_F &= 65 \\
 N_A &= 975 \text{ rpm}
 \end{aligned}$$

$$\frac{N_F}{N_A} = \frac{T_A}{T_B} \times \frac{T_C}{T_D} \times \frac{T_E}{T_F}$$

$$\therefore \frac{N_F}{975} = \frac{20}{50} \times \frac{25}{75} \times \frac{26}{65}$$

$$\boxed{\therefore N_F = 52 \text{ rpm}}$$

Example 5.2 In an epicyclic gear train, an arm carries two gears A and B having 36 and 45 teeth respectively. If the arm rotates at 150 rpm in the anticlockwise direction about the center of the gear A which is fixed, determine the speed of gear B. If the gear A instead of being fixed makes 300 rpm in the clockwise direction, what will be the speed of gear B?

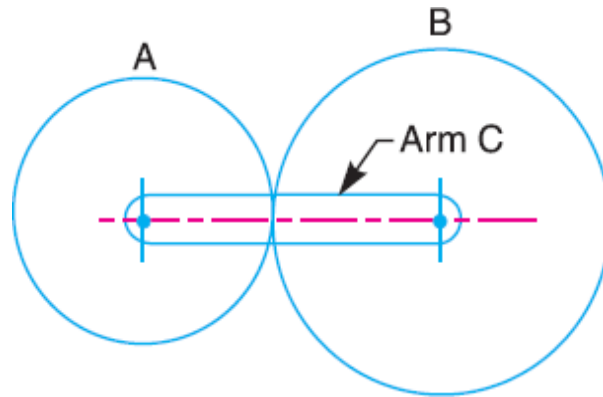

Fig.6.2

Solution :

Given data

$$T_A = 36$$

$$T_B = 45$$

$$? N_C = 150 \text{ (Anticlockwise)}$$

Find

$$\text{Gear A fixed} \Rightarrow N_B = ?$$

$$N_A = -300 \text{ (Clockwise)} \Rightarrow N_B = ?$$

Sr. No.	Condition of motion	Revolution of element		
		Arm C	Gear A	Gear B
1	Arm fixe, gear A rotates +1 revolution(anticlockwise)	0	+1	$-\frac{T_A}{T_B}$
2	Arm fixed gear A rotates through + x revolutions	0	+x	$-\frac{T_A}{T_B} x$
3	Add + y revolutions to all elements	+ y	+ y	+ y
4	Total motion	+ y	x + y	$y - x \frac{T_A}{T_B}$

1. Speed of gear B (N_B) when gear A is fixed

Here, gear A fixed

$$\Rightarrow x + y = 0$$

$$\Rightarrow x + 150 = 0$$

$$\Rightarrow x = -150$$

$$\begin{aligned}
 \text{Speed of gear B} &= y - x \frac{T_A}{T_B} \\
 (N_B) &= y - (-150) \frac{36}{45} \\
 &= +270 \text{rpm (Anticlockwise)}
 \end{aligned}$$

2. Speed of gear B (N_B) when gear $N_A = -300$ (Clockwise)

Here given

$$\begin{aligned}
 x + y &= -300 \\
 \therefore x + 150 &= -300 \\
 \therefore x &= -450 \text{ rpm}
 \end{aligned}$$

Speed of gear B (N_B)

$$\begin{aligned}
 &= y - x \frac{T_A}{T_B} \\
 &= 150 - (-450) \frac{36}{45} \\
 &= +510 \text{ rpm (Anti clockwise)}
 \end{aligned}$$

Example 5.3 In a reverted epicyclic gear train, the arm A carries two gears B and C and a compound gear D - E. The gear B meshes with gear E and the gear C meshes with gear D. The number of teeth on gears B, C and D are 75, 30 and 90 respectively. Find the speed and direction of gear C when gear B is fixed and the arm A makes 100 rpm clockwise.

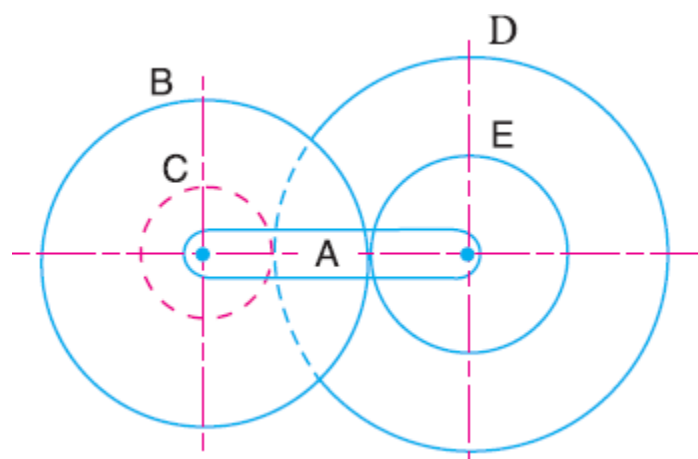

Fig. 6.3

Solution Given data find

$$\begin{aligned}
 T_B &= 75 & \text{Gear B fixed} &\Rightarrow N_C = ? \\
 T_C &= 30 & N_A &= -100 \Rightarrow N_C = ? \\
 T_D &= 90 \\
 N_A &= -100 \text{ (Clockwise)}
 \end{aligned}$$

$$\begin{aligned}
 \text{Let } d_C + d_D &= d_B + d_E & (r_C + r_D &= r_B + r_E) \\
 \therefore T_C + T_D &= T_B + T_E \\
 \therefore 30 + 90 &= 75 + \\
 &T_E \\
 \therefore T_E &= 45
 \end{aligned}$$

Sr. No.	Condition of motion	Revolution of element			
		Arm C	Gear A	Gear B	Gear C
1	Arm fixe, gear A rotates +1 revolution(anticlockwise)	0	+1	$-\frac{T_E}{T_B}$	$-\frac{T_D}{T_C}$
2	Arm fixed gear A rotates through + x revolutions	0	+x	$-x \frac{T_E}{T_B}$	$-x \frac{T_D}{T_C}$
3	Add + y revolutions to all elements	+ y	+ y	+ y	+ y
4	Total motion	+ y	x + y	$y - x \frac{T_E}{T_B}$	$y - x \frac{T_D}{T_C}$

$$\begin{aligned}
 \text{Gear B is fixed} &\Rightarrow y - x \frac{T_E}{T_B} = 0 \\
 &\Rightarrow -100 - x \frac{45}{75} = 0 \\
 &\Rightarrow x = -166.67
 \end{aligned}$$

$$\begin{aligned}
 \text{Speed of gear C } (N_C) &= y - x \frac{T_D}{T_C} \\
 &= -100 - (-166.67) \times \frac{90}{30} \\
 &= +400 \text{ rpm (Anti clockwise)}
 \end{aligned}$$

Sr. No.	Condition of motion	Revolution of element			
		Arm C	Gear A	Gear B	Gear C
1	Arm fixe, gear A rotates +1 revolution(anticlockwise)	0	+1	$-\frac{T_B}{T_E}$	$+\frac{T_B}{T_E} \times \frac{T_D}{T_C}$
2	Arm fixed gear A rotates through +x revolutions	0	+x	$x \frac{T_B}{T_E}$	$+x \frac{T_B}{T_E} \times \frac{T_D}{T_C}$
3	Add +y revolutions to all elements	+y	+y	+y	+y
4	Total motion	+y	x+y	$y - x \frac{T_B}{T_E}$	$y + x \frac{T_B}{T_E} \times \frac{T_D}{T_C}$

From fig $(r_C + r_D = r_B + r_E)$

$$\therefore T_C + T_D = T_B + T_E$$

$$\therefore T_E = 90 + 30 - 75$$

$$\therefore T_E = 45$$

When gear B is fixed

$$\therefore x + y = 0$$

$$\therefore x + (-100) = 0$$

$$\therefore x = 100$$

$$\begin{aligned} \text{Now } N_C &= y + x \frac{T_B}{T_E} \times \frac{T_D}{T_C} \\ &= -100 + 100 \times \frac{75}{45} \times \frac{90}{30} \end{aligned}$$

$$\boxed{N_C = 400 \text{ rpm (Anticlockwise)}}$$

Example 5.4 An epicyclic gear consists of three gears A, B and C as shown in Fig. The gear A has 72 internal teeth and gear C has 32 external teeth. The gear B meshes with both A and C and is carried on an arm EF which rotates about the centre of A at 18 rpm. If the gear A is fixed, determine the speed of gears B and C.

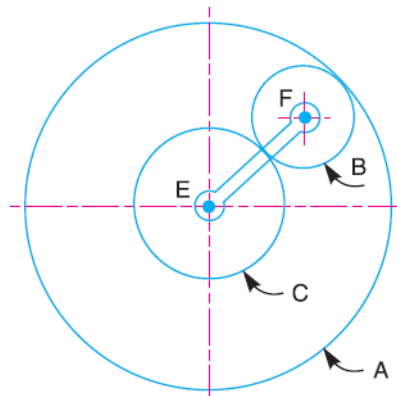

Fig. 6.4

Solution:

$$T_B = 72 \text{ (Internal)}$$

$$T_C = 32$$

(External) Arm

$$EF = 18 \text{ rpm}$$

$$\text{Gear A fixed} \Rightarrow N_B = ?$$

$$\Rightarrow N_C = ?$$

From the geometry of fig.

$$r_A = r_C + 2r_B$$

$$\therefore T_A = T_C + 2T_B$$

$$\therefore T_B = 20$$

Sr. No.	Condition of motion	Revolution of element			
		Arm C	Gear A	Gear B	Gear C
1	Arm fixe, gear A rotates +1 revolution(anticlockwise)	0	+1	$-\frac{T_C}{T_B}$	$-\frac{T_C}{T_B} \times \frac{T_B}{T_A} = -\frac{T_C}{T_A}$
2	Arm fixed gear A rotates through +x revolutions	0	+x	$-x \frac{T_C}{T_B}$	$-x \frac{T_C}{T_A}$
3	Add +y revolutions to all elements	+y	+y	+y	+y
4	Total motion	y	x+y	$y - x \frac{T_C}{T_B}$	$y - x \frac{T_C}{T_A}$

1. Speed of gear C (N_C)

$$\text{Gear A is fixed} \Rightarrow y - x \frac{T_C}{T_A} = 0$$

$$\Rightarrow -18 - x \frac{32}{72} = 0$$

$$\Rightarrow x = -40.5$$

$$\text{Speed of gear C } (N_C) = x + y$$

$$= 40.5 + 18$$

$$= 58.5 \text{ rpm (in the direction of arm)}$$

2. Speed of gear B (N_B)

$$\text{Speed of gear B} = y - x \frac{T_C}{T_B}$$

$$= -18 - 40.5 \times \frac{32}{20}$$

$$= -46.8 \text{ rpm}$$

$$= 46.8 \text{ rpm (in the opposite direction of arm)}$$

Example 5.5 Two shafts A and B are co-axial. A gear C (50 teeth) is rigidly mounted on shaft A. A compound gear D-E gears with C and an internal gear G. D has 20 teeth and gears with C and E has 35 teeth and gears with an internal gear G. The gear G is fixed and is concentric with the shaft axis. The compound gear D-E is mounted on a pin which projects from an arm keyed to the shaft B. Sketch the arrangement and find the number of teeth on internal gear G assuming that all gears have the same module. If the shaft A rotates at 110 rpm, find the speed of shaft B.

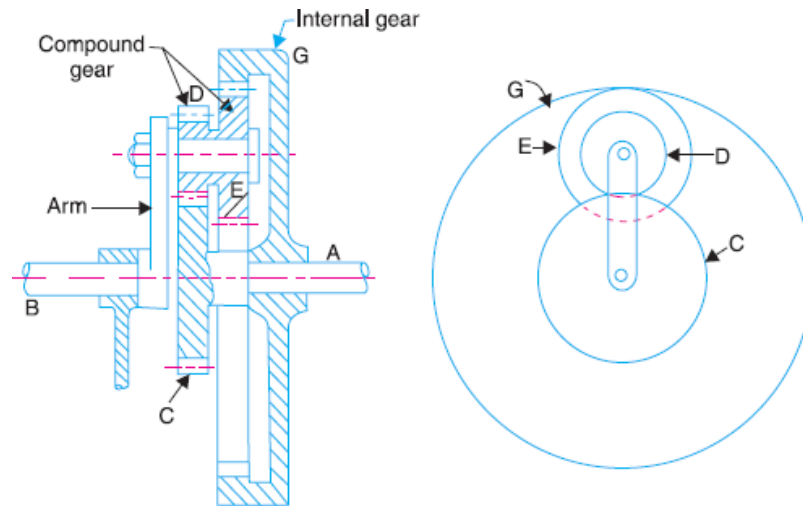

Fig 6.5

Solution:

$$T_C = 50$$

No. of teeth on internal gear = ?

$$T_D = 20$$

Speed of shaft B = ?

$$T_E = 35$$

$$N_C = 110 \text{ (Rotation of shaft)}$$

From the geometry of fig.

$$\frac{d_G}{2} = \frac{d_C}{2} + \frac{d_D}{2} + \frac{d_E}{2}$$

$$\therefore d_G = d_C + d_D + d_E$$

$$\therefore T_G = T_C + T_D + T_E$$

$$\therefore T_G = 50 + 20 + 35$$

$$\therefore T_G = 105$$

Sr. No.	Condition of motion	Revolution of element			
		Arm C	Gear C (Shaft A)	Compound Gear (D-E)	Gear G
1	Arm fixe, gear A rotates +1 revolution(anticlockwise)	0	+1	$-\frac{T_C}{T_D}$	$-\frac{T_C \times T_E}{T_D \times T_G}$
2	Arm fixed gear A rotates through + x revolutions	0	+x	$-x \frac{T_C}{T_D}$	$-x \frac{T_C \times T_E}{T_D \times T_G}$
3	Add + y revolutions to all elements	+y	+y	+y	+y
4	Total motion	y	x+y	$y - x \frac{T_C}{T_D}$	$y - x \frac{T_C \times T_E}{T_D \times T_G}$

Speed of shaft B

Here given gear G is fixed

$$\therefore y - x \frac{T_C}{T_D} \times \frac{T_E}{T_G} = 0$$

$$\therefore y - x \frac{50}{20} \times \frac{35}{105} = 0$$

$$\therefore y - x \times \frac{5}{6} = 0 \quad \dots\dots\dots(1)$$

Also given gear C is rigidly mounted on shaft A

$$\therefore x + y = 110 \quad \dots\dots\dots(2)$$

Solving eq. (1) & (2)

$$x = 60$$

$$y = 50$$

Speed of shaft B = Speed of arm = + y = 50 rpm

Example 6.6: In an epicyclic gear train, as shown in Fig.13.33, the number of teeth on wheels A, B and C are 48, 24 and 50 respectively. If the arm rotates at 400 rpm, clockwise,

- Find:** 1. Speed of wheel C when A is fixed, and
 2. Speed of wheel A when C is fixed

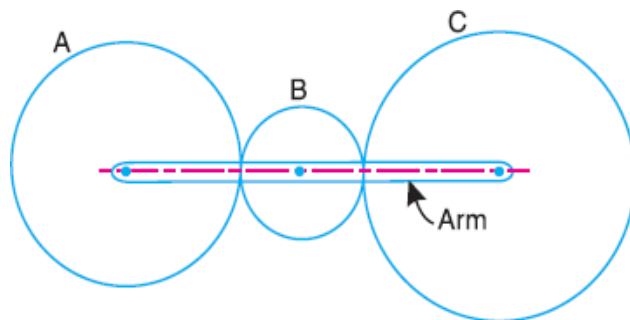

Fig. 6.6

Solution:

$$T_A = 48$$

$$T_B = 24$$

$$T_C = 50$$

$$\text{Gear A fixed} \Rightarrow N_C = ?$$

$$\text{Gear C fixed} \Rightarrow N_A = ?$$

$$y = -400 \text{ rpm (Arm rotation clockwise)}$$

Sr. No.	Condition of motion	Revolution of element			
		Arm C	Gear A	Gear B	Gear C
1	Arm fixed, gear A rotates +1 revolution (anticlockwise)	0	+1	$-\frac{T_A}{T_B}$	$\left(-\frac{T_A}{T_B}\right) \times \left(-\frac{T_B}{T_C}\right) = +\frac{T_A}{T_C}$
2	Arm fixed gear A rotates through +x revolutions	0	+x	$-x \frac{T_A}{T_B}$	$+x \frac{T_A}{T_C}$
3	Add +y revolutions to all elements	+y	+y	+y	+y
4	Total motion	y	x+y	$y - x \frac{T_A}{T_B}$	$y + x \frac{T_A}{T_C}$

1. Speed of wheel C when A is fixed

When A is fixed

$$\Rightarrow x + y = 0$$

$$\Rightarrow x - 400 = 0$$

$$\Rightarrow x = 400$$

$$N_C = y + x \frac{T_A}{T_C}$$

$$= -400 + 400 \times \frac{48}{50}$$

$$= -16 \text{ rpm}$$

$$N_C = 16 \text{ rpm (Clockwise direction)}$$

2. Speed wheel A when C is fixed

When C is fixed

$$\therefore N_C = 0$$

$$\therefore y + x \frac{T_A}{T_C} = 0$$

$$\therefore -400 + x \frac{48}{50} = 0$$

$$\therefore x = 416.67$$

$$N_A = x + y$$

$$= 416.67 - 400$$

$$N_A = 16.67$$

Example 5.7: An epicyclic gear train, as shown in Fig. 13.37, has a sun wheel *S* of 30 teeth and two planet wheels *P-P* of 50 teeth. The planet wheels mesh with the internal teeth of a fixed annulus *A*. The driving shaft carrying the sunwheel transmits 4 kW at 300 rpm. The driven shaft is connected to an arm which carries the planet wheels. Determine the speed of the driven shaft and the torque transmitted, if the overall efficiency is 95%.

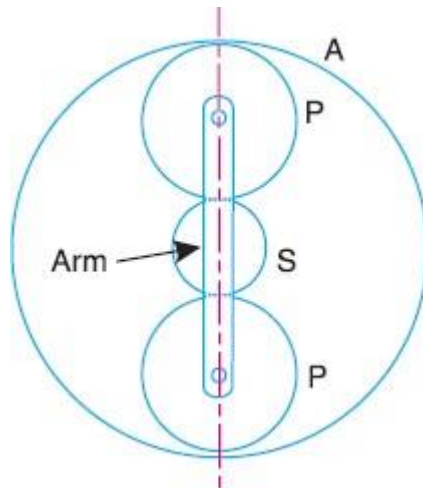

Fig.6.7

Solution

$$T_S = 30 \quad T_P = 50 \quad T_A = 130$$

$$N_S = 300 \text{ rpm} \quad P = 4 \text{ KW}$$

From the geometry of fig.

$$r_A = 2r_p + r_s$$

$$\therefore T_A = 2T_p + T_s$$

$$= 2 \times 50 + 30$$

$$= 130$$

Sr. No.	Condition of motion	Revolution of element			
		Arm C	Gear A	Gear B	Gear C
1	Arm fixe, gear A rotates +1 revolution(anticlockwise)	0	+1	$-\frac{T_S}{T_P}$	$\begin{pmatrix} -T_S \\ T_P \end{pmatrix} \times \begin{pmatrix} T_P \\ T_A \end{pmatrix} = +\frac{T_S}{T_A}$
2	Arm fixed gear A rotates through + x revolutions	0	+x	$-x\frac{T_S}{T_P}$	$-x\frac{T_S}{T_A}$
3	Add + y revolutions to all elements	+ y	+ y	+ y	+ y
4	Total motion	y	x + y	$y - x\frac{T_S}{T_P}$	$y - x\frac{T_S}{T_A}$

Here,

$$N_s = 300 \text{ rpm}$$

$$\therefore x + y = 300 \quad \dots\dots\dots(1)$$

Also, Annular gear A is fixed

$$\therefore y - x \frac{T_s}{T_A} = 0$$

$$\therefore y - x \times \frac{30}{130} = 0$$

$$\therefore y = 0.23x \quad \dots\dots\dots(2)$$

Solving equation eq. (1) & (2)

$$x = 243.75$$

$$y = 56.25$$

Speed of Arm = Speed of driven shaft = $y = 56.25 \text{ rpm}$

Here, $P = 4 \text{ KW}$ $\eta = 95\%$

&

$$\therefore \eta = \frac{P_{\text{out}}}{P_{\text{in}}}$$

$$\therefore P_{\text{out}} = \eta \times P_{\text{in}}$$

$$= \frac{95}{100} \times 4$$

$$= 3.8 \text{ KW}$$

Also,

$$P_{\text{out}} = \frac{2\pi N T}{60}$$

$$\therefore 3.8 \times 10^3 = \frac{2\pi \times 56.30 T}{60}$$

$$\therefore T = 644.5 \text{ N}\cdot\text{m}$$

Example 6.8 An epicyclic gear train is shown in fig. Find out the rpm of pinion D if arm A rotate at 60 rpm in anticlockwise direction. No of teeth on wheels are given below.

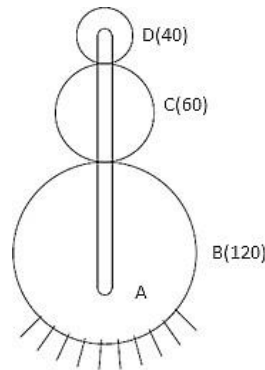

Fig.6.8

Solution:

$$T_D = 40 \quad N_D = ?$$

$$T_C = 60$$

$$T_B = 120$$

$$N_A = +60 \text{ rpm (Anticlockwise)}$$

Sr. No.	Condition of motion	Revolution of element			
		Arm C	Gear B	Gear C	Gear D
1	Arm fixe, gear A rotates +1 revolution(anticlockwise)	0	+1	$-\frac{T_B}{T_C}$	$\frac{T_B}{T_C} \times \frac{T_C}{T_D} = +\frac{T_B}{T_D}$
2	Arm fixed gear A rotates through + x revolutions	0	+x	$-x \frac{T_B}{T_C}$	$+x \frac{T_B}{T_D}$
3	Add + y revolutions to all elements	+ y	+ y	+ y	+ y
4	Total motion	y	x + y	$y - x \frac{T_B}{T_C}$	$y + x \frac{T_B}{T_D}$

From fig. Gear B is fixed

$$\therefore x + y = 0$$

$$\therefore x + 60 = 0 \quad (\therefore \text{rpm of arm A} = 60 = y)$$

$$\therefore x = -60$$

Now motion of gear D

$$= y + x \frac{T_B}{T_D}$$

$$= 60 - 60 \times \frac{120}{40}$$

$$= -120 \text{ rpm}$$

D rotates 120 rpm in clockwise direction.

Note: By fixing any gear C OR B this problem can be solved

Example 6.9 An epicyclic gear train for an electric motor is shown in Fig. The wheel *S* has 15 teeth and is fixed to the motor shaft rotating at 1450 rpm. The planet *P* has 45 teeth, gears with fixed annulus *A* and rotates on a spindle carried by an arm which is fixed to the output shaft. The planet *P* also gears with the sun wheel *S*. Find the speed of the output shaft. If the motor is transmitting 1.5 kW, find the torque required to fix the annulus *A*.

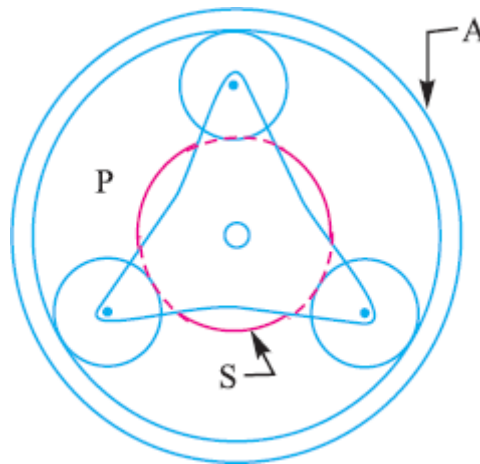

Fig. 6.9

Solution:

$T_s = 15$ Speed of output shaft = ?
 $T_p = 45$ Torque = ?

From fig.

$$r_A = r_s + 2r_p$$

$$\therefore T_A = T_s + 2T_p$$

$$\therefore T_A = 105$$

Sr. No.	Condition of motion	Revolution of element			
		Spindle	Gear S	Gear P	Gear A
1	Sector/Spindle fixed, gear S rotates +1 revolution (anticlockwise)	0	+1	$-\frac{T_s}{T_p}$	$-\frac{T_s}{T_p} \times \frac{T_p}{T_A} = -\frac{T_s}{T_A}$
2	Spindle fixed gear S rotates through + x revolutions	0	+x	$-x \frac{T_s}{T_p}$	$-x \frac{T_s}{T_A}$
3	Add + y revolutions to all elements	+ y	+ y	+ y	+ y
4	Total motion	y	x + y	$y - x \frac{T_s}{T_p}$	$y - x \frac{T_s}{T_A}$

Motor shaft is fixed with gear S

$$\therefore x + y = 1450 \quad \dots\dots\dots(1)$$

And Annular A is fixed

$$\begin{aligned} \therefore y - x \frac{T_S}{T_A} &= 0 \\ \therefore y - x \frac{15}{105} &= 0 \\ \therefore y &= x \frac{15}{105} \quad \dots\dots\dots(2) \end{aligned}$$

By solving equation (1) & (2)

$$x = 1268.76$$

$$y = 181.25$$

Speed of output shaft $y = 181.25$ rpm

- Torque on sun wheel (S) (input torque)

$$\begin{aligned} P &= \frac{2\pi N T_i}{60} \\ \therefore T_i &= \frac{P \times 60}{2\pi N} \\ &= \left(\frac{2 \times 10^3}{1.35} \right) \times \frac{60}{2\pi \times 1450} \quad \left(\begin{array}{l} \therefore 1.35 \text{ HRW} \Rightarrow 2 \\ \text{KW} \end{array} \right) \\ &= 9.75 \text{ N}\cdot\text{m} \end{aligned}$$

- Torque on output shaft (with 100% mechanical efficiency)

$$\begin{aligned} \therefore T_o &= \frac{P \times 60}{2\pi N} \\ &= \left(\frac{2 \times 10^3}{1.35} \right) \times \frac{60}{2\pi \times 181.25} \\ &= 78.05 \text{ N}\cdot\text{m} \end{aligned}$$

- Fixing torque

$$\begin{aligned} &= T_o - T_i \\ &= 78.05 - 9.75 \\ &= 68.3 \text{ N}\cdot\text{m} \end{aligned}$$

Example 6.10: If wheel D of gear train as shown in fig. is fixed and the arm A makes 140 revolutions in a clockwise direction. Find the speed and direction of rotation of B & E. C is a compound wheel.

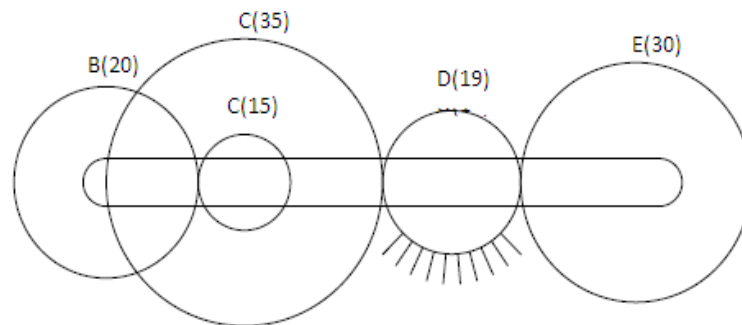

Fig.6.10

Solution:

$$T_B = 20 \quad T_C = 15 \quad T_D = 19 \quad T_E = 30$$

Sr. No.	Condition of motion	Revolution of element			
		Spindle	Gear S	Gear P	Gear A
1	Arm fixed, gear A rotates +1 revolution (anticlockwise)	0	+1	$-\frac{20}{15}$	$\left(-\frac{20}{15}\right) \times \left(-\frac{35}{19}\right) \times \left(-\frac{19}{30}\right)$
2	Arm fixed gear A rotates through +x revolutions	0	+x	-1.33x	-1.555x
3	Add +y revolutions to all elements	+y	+y	+y	+y
4	Total motion	y	x+y	y-1.33x	y-1.555x

- When gear D is fixed

$$y + 2.456x = 0$$

$$\therefore -140 + 2.456x = 0$$

$$(\because y = -140 \text{ rpm given})$$

$$\therefore x = 57$$

- Speed of gear B

$$N_B = x + y$$

$$= +57 - 140$$

$$= -83 \text{ rpm (Clockwise)}$$

- Speed of gear E

$$N_E = y - 1.555x$$

$$= -140 - 1.555(57)$$

$$= -228.63 \text{ rpm (Clockwise)}$$

Example 6.11: The epicyclic train as shown in fig. is composed of a fixed annular wheel A having 150 teeth. Meshing with A is a wheel b which drives wheel D through an idle wheel C, D being concentric with A. Wheel B and C are carried on an arm which revolve clockwise at 100 rpm about the axis of A or D. If the wheels B and D are having 25 teeth and 40 teeth respectively, Find the no. of teeth on C and speed and sense of rotation of C.

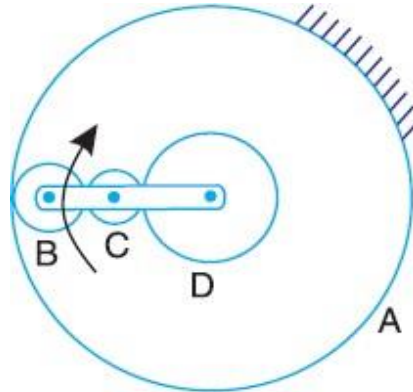

Fig. 6.11

Solution:

From the geometry of fig.

$$r_A = 2r_B + 2r_C + r_D$$

$$\therefore T_A = 2T_B + 2T_C + T_D$$

$$\therefore 150 = 50 + 2T_C + 40$$

$$\therefore T_C = 30$$

Sr. No.	Condition of motion	Revolution of element				
		Arm	Gear D	Gear C	Gear B	Gear A
1	Arm fixe, gear D rotates +1 revolution (anticlockwise)	0	+1	$-\frac{T_D}{T_C}$	$+\frac{T_D}{T_B}$	$+\frac{T_D}{T_A}$
2	Arm fixed gear D rotates through + x revolutions	0	+x	$-x\frac{T_D}{T_C}$	$+x\frac{T_D}{T_B}$	$+x\frac{T_D}{T_A}$
3	Add + y revolutions to all elements	+ y	+ y	+ y	+ y	+ y
4	Total motion	+ y	x + y	$y - x\frac{T_D}{T_C}$	$y + x\frac{T_D}{T_B}$	$y + x\frac{T_D}{T_A}$

Now

$$N_A = 0$$

$$\therefore y + x \frac{T_D}{T_A} = 0$$

$$\therefore -100 + x \times \frac{40}{150} = 0$$

$$\therefore x = 375$$

Let

$$N_C = y - x \frac{T_D}{T_C}$$

$$= -100 - 375 \times \frac{40}{30}$$

$$= -600 \text{rpm}$$

Example 6.12: Fig. 13.24 shows a differential gear used in a motor car. The pinion A on the propeller shaft has 12 teeth and gears with the crown gear B which has 60 teeth. The shafts P and Q form the rear axles to which the road wheels are attached. If the propeller shaft rotates at 1000 rpm and the road wheel attached to axle Q has a speed of 210 rpm. while taking a turn, find the speed of road wheel attached to axle P.

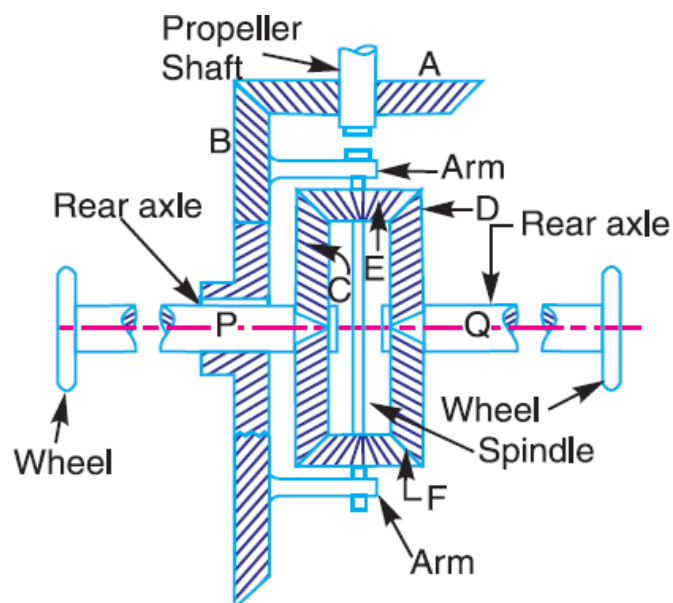

Fig. 6.12

Solution:

$$T_A = 12$$

$$T_B = 60$$

$$N_Q = N_D = 210 \text{rpm}$$

$$N_A = 1000 \text{rpm}$$

Let

$$\begin{aligned} N_A \times T_A &= N_B T_B \\ \therefore N_B &= N_A \times \frac{T_A}{T_B} \\ &= 1000 \times \frac{12}{60} \\ &= 200 \text{rpm} \end{aligned}$$

Sr. No.	Condition of motion	Revolution of element			
		Gear B	Gear C	Gear E	Gear D
1	Gear B is fixed, gear C rotates +1 revolution(anticlockwise)	0	+1	$+\frac{T_C}{T_E}$	-1
2	Gear B is fixed gear C rotates through + x revolutions	0	+x	$+\frac{x T_C}{T_E}$	-x
3	Add + y revolutions to all elements	+ y	+ y	+ y	+ y
4	Total motion	+ y	x + y	$y + x \frac{T_C}{T_E}$	y - x

Let here speed of gear B is 200 rpm

$$N_B = 200 = y$$

From table

$$N_D = y - x = 210$$

$$\therefore x = y - 210$$

$$\therefore x = 200 - 210$$

$$\therefore x = -10 \text{rpm}$$

Let speed of road wheel attached to the axle P = Speed of gear C

$$= x + y$$

$$= -10 + 200$$

$$= 180 \text{rpm}$$

Example 6.13: Two bevel gears A and B (having 40 teeth and 30 teeth) are rigidly mounted on two co-axial shafts X and Y. A bevel gear C (having 50 teeth) meshes with A and B and rotates freely on one end of an arm. At the other end of the arm is welded a sleeve and the sleeve is riding freely loose on the axes of the shafts X and Y. Sketch the arrangement. If the shaft X rotates at 100 rpm. clockwise and arm rotates at 100 rpm. anticlockwise, find the speed of shaft Y.

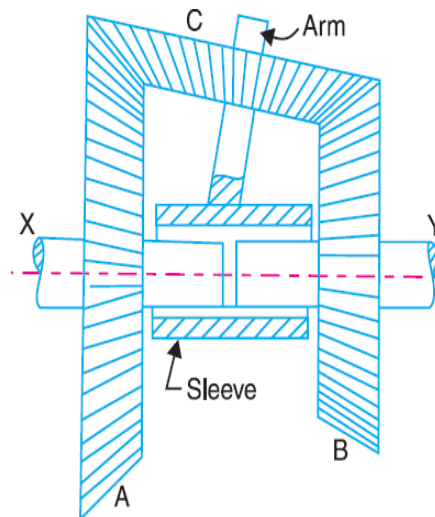

Fig.
6.13

Solution

:

$$T_A = 40 \quad T_C = 50 \quad T_B = 30$$

$$N_X = N_A = -100 \text{ rpm (Clockwise)}$$

$$\text{Speed of arm} = 100 \text{ rpm}$$

Sr. No.	Condition of motion	Revolution of element			
		Arm	Gear A	Gear C	Gear B
1	Arm fixe, gear A rotates +1 revolution(anticlockwise)	0	+1	$\pm \frac{T_A}{T_C}$	$-\frac{T_A}{T_B}$
2	Arm fixed gear A rotates through + x revolutions	0	+x	$\pm x \frac{T_A}{T_C}$	$-x \frac{T_A}{T_B}$
3	Add + y revolutions to all elements	+ y	+ y	+ y	+ y
4	Total motion	+ y	x + y	$y \pm x \frac{T_A}{T_C}$	$y - x \frac{T_A}{T_B}$

Here speed of arm = $y = +100$ rpm (given)

$$\text{Also given } N_A = N_X = -100 \text{ rpm}$$

$$\therefore N_A = x + y$$

$$\therefore -100 = x + 100$$

$$\therefore x = -200$$

Speed of shaft Y =

N_B

$$= y - x \frac{T_A}{T_B}$$

$$= 100 + 200 \times \frac{40}{30}$$

$$= +366.7 \text{ rpm (Anticlockwise)}$$

Example 6.14. An epicyclic train of gears is arranged as shown in Fig. How many revolutions does the arm, to which the pinions B and C are attached, make: 1. when A makes one revolution clockwise and D makes half a revolution anticlockwise, and 2. when A makes one revolution clockwise and D is stationary? The number of teeth on the gears A and D are 40 and 90 respectively.

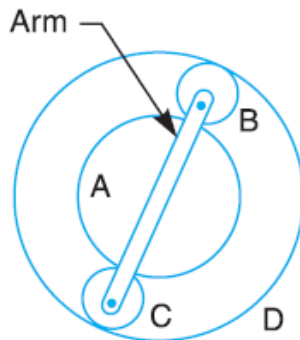

Fig. 6.14

Solution:

$$T_A = 40$$

$$T_D = 90$$

First of all, let us find the number of teeth on gear B and C (i.e. T_B and T_C). Let d_A, d_B, d_C, d_D be the pitch circle diameter of gears A, B, C, and D respectively. Therefore from the geometry of fig,

$$d_A + d_B + d_C = d_D \quad \text{or} \quad d_A + 2d_B = d_D \quad \dots (d_B = d_C)$$

Since the number of teeth are proportional to their pitch circle diameters, therefore,

$$T_A + 2T_B = T_D \quad \text{or} \quad 40 + 2T_B = 90$$

$$\therefore T_B = 25, \text{ and } T_C = 25 \quad \dots (T_B = T_C)$$

Sr. No.	Conditions of motion	Revolutions of elements			
		Arm	Gear A	Compound Gear B-C	Gear D
1	Arm fixe, gear A rotates -1 revolution(clockwise)	0	-1	$+\frac{T_A}{T_B}$	$\left(+\frac{T_A}{T_B}\right) \times \left(+\frac{T_B}{T_D}\right) = +\frac{T_A}{T_D}$
2	Arm fixed gear A rotates through - x revolutions	0	-x	$+x \frac{T_A}{T_B}$	$+x \frac{T_A}{T_D}$
3	Add - y revolutions to all elements	-y	-y	-y	-y
4	Total motion	-y	-x-y	$x \frac{T_A}{T_B} - y$	$x \frac{T_A}{T_D} - y$

1. Speed of arm when A makes 1 revolution clockwise and D makes half revolution anticlockwise

Since the gear A makes 1 revolution clockwise, therefore from the fourth row of the table,

$$-x - y = -1 \quad \text{or} \quad x + y = 1 \quad \dots(1)$$

Also, the gear D makes half revolution anticlockwise, therefore

$$\begin{aligned}
 x \times \frac{T_A}{T_D} - y &= \frac{1}{2} \\
 \therefore x \times \frac{40}{90} - y &= \frac{1}{2} \\
 \therefore 40x - 90y &= 45 \\
 \therefore x - 2.25y &= 1.125 \quad \dots(2)
 \end{aligned}$$

From equations (1) and (2),

$$x = 1.04 \quad \text{and} \quad y = -0.04$$

Speedofarm = $-y = -(-0.04) = +0.04$

$$\boxed{=0.04 \text{ revolution(Anticlockwise)}}$$

2. Speed of arm when A makes 1 revolution clockwise and D is stationary

Since the gear A makes 1 revolution clockwise, therefore from the fourth row of the table,

$$\begin{aligned}
 -x - y &= -1 \\
 \therefore x + y &= 1 \quad \dots(3)
 \end{aligned}$$

Also the gear D is stationary, therefore

$$\begin{aligned}
 x \times \frac{T_A}{T_D} - y &= 0 \\
 \therefore x \times \frac{40}{90} - y &= 0 \\
 \therefore 40x - 90y &= 0 \\
 \therefore x - 2.25y &= 0 \quad \dots(4)
 \end{aligned}$$

From equations (3) and (4),

$$\therefore \text{Speedof arm} = -y = -0.308$$

$$\boxed{\therefore \text{Speedof arm} = 0.308 \text{ revolution (Clockwise)}}$$

Example 6.15. In an epicyclic gear train, the internal wheels A and B and compound wheels C and D rotate independently about axis O. The wheels E and F rotate on pins fixed to the arm G. E gears with A and C and F gears with B and D. All the wheels have the same module and the number of teeth is: $T_C = 28$; $T_D = 26$; $T_E = T_F = 18$. 1. Sketch the arrangement; 2. Find the number of teeth on A and B; 3. If the arm G makes 100 r.p.m. clockwise and A is fixed, find the speed of B; and 4. If the arm G makes 100 r.p.m. clockwise and wheel A makes 10 r.p.m. counter clockwise; find the speed of Wheel B.
Solution:

$$\text{Given: } T_C = 28 ; T_D = 26 ; T_E = T_F = 18$$

1. Sketch the arrangement

The arrangement is shown in Fig.

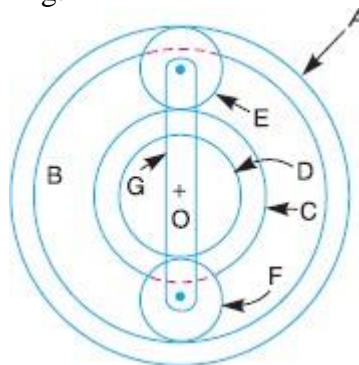

Fig. 6.15

2. Number of teeth on wheels A and B

T_A = Number of teeth on wheel A, and

T_B = Number of teeth on wheel B.

If d_A, d_B, d_C, d_D, d_E and d_F are the pitch circle diameters of wheels A, B, C, D, E and F respectively, then from the geometry of Fig.

$$d_A = d_C + 2 d_E$$

$$\text{And } d_B = d_D + 2 d_F$$

Since the number of teeth are proportional to their pitch circle diameters, for the same module, therefore

$$T_A = T_C + 2 T_E = 28 + 2 = 64$$

$$\text{And } T_B = T_D + 2 T_F = 26 + 2 = 62$$

3. Speed of wheel B when arm G makes 100 r.p.m. clockwise and wheel A is fixed

First of all, the table of motions is drawn as given below:

Sr. No	Conditions of motion	Revolutions of elements					
		Arm G	Wheel A	Wheel E	Compound wheel C-D	Wheel F	Wheel B
1	Arm fixe, A rotates +1 revolution (Anti clockwise)	0	+1	$+\frac{T_A}{T_E}$	$-\frac{T_A}{T_E} \times \frac{T_E}{T_C}$ $= -\frac{T_A}{T_C}$	$+\frac{T_A}{T_C} \times \frac{T_D}{T_F}$	$+\frac{T_A}{T_C} \times \frac{T_D}{T_F} \times \frac{T_F}{T_B}$ $= +\frac{T_A}{T_C} \times \frac{T_D}{T_B}$
2	Arm fixed A rotates through + x revolutions	0	+x	$+x \frac{T_A}{T_E}$	$-x \frac{T_A}{T_C}$	$+x \times \frac{T_A}{T_C} \times \frac{T_D}{T_F}$	$+x \times \frac{T_A}{T_C} \times \frac{T_D}{T_B}$
3	Add +y revolutions to all elements	+y	+y	+y	+y	+y	+y
4	Total motion	+y	x + y	$x \frac{T_A}{T_E} + y$	$y - x \frac{T_A}{T_C}$	$y + x \times \frac{T_A}{T_C} \times \frac{T_D}{T_F}$	$+y + x \times \frac{T_A}{T_C} \times \frac{T_D}{T_B}$

Since the arm G makes 100 r.p.m. clockwise, therefore from the fourth row of the table

$$y = -100$$

Also, the wheel A is fixed, therefore from the fourth row of the table,

$$x + y = 0 \quad \text{or} \quad x = -y = 100$$

$$\begin{aligned} \text{Speed of wheel B} &= y + x \times \frac{T_A}{T_C} \times \frac{T_D}{T_B} \\ &= -100 + 100 \times \frac{64}{28} \times \frac{26}{62} \\ &= -100 + 95.8 \text{ r.p.m.} = -4.2 \text{ r.p.m} \end{aligned}$$

Speed of wheel B = 4.2 r.p.m

4. Speed of wheel B when arm G makes 100 r.p.m. clockwise and wheel A makes 10 r.p.m. counter clockwise

Since the arm G makes 100 r.p.m. clockwise, therefore from the fourth row of the table

$$y = -100 \quad \dots(3)$$

Also the wheel A makes 10 r.p.m. counter clockwise, therefore from the fourth row of the table,

$$\begin{aligned} x + y &= 10 \\ \therefore x &= 10 - y \\ \therefore x &= 10 + 100 \\ \therefore x &= 110 \quad \dots(4) \end{aligned}$$

$$\begin{aligned} \therefore \text{Speed of wheel B} &= y + x \times \frac{T_A}{T_C} \times \frac{T_D}{T_B} \\ &= -100 + 110 \times \frac{64}{28} \times \frac{26}{62} \\ &= -100 + 105.4 \text{ r.p.m} \\ &= +5.4 \text{ r.p.m} \end{aligned}$$

\therefore Speed of wheel B = 5.4 r.p.m

Example 6.16. Fig. shows diagrammatically a compound epicyclic gear train. Wheels A , D and E are free to rotate independently on spindle O , while B and C are compound and rotate together on spindle P , on the end of arm OP . All the teeth on different wheels have the same module. A has 12 teeth, B has 30 teeth and C has 14 teeth cut externally. Find the number of teeth on wheels D and E which are cut internally. If the wheel A is driven clockwise at 1 r.p.s. while D is driven counter clockwise at 5 r.p.s., determine the magnitude and direction of the angular velocities of arm OP and wheel E .

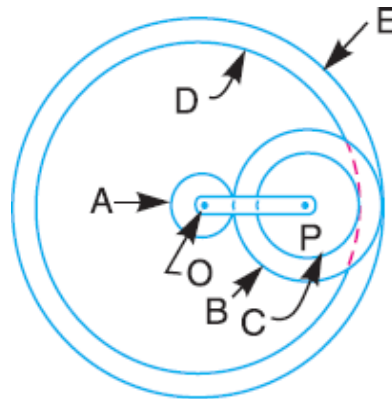

Fig. 6.16

Solution:

Given: $T_A=12$; $T_B= 30$; $T_C=14$; $N_A=1$ r.p.s.; $N_D=5$ r.p.s

Number of teeth on wheels D and E

Let T_D and T_E be the number of teeth on wheels D and E respectively. Let d_A , d_B , d_C , d_D and d_E be the pitch circle diameters of wheels A, B, C, D and E respectively. From the geometry of the figure,

$$d_E = d_A + 2d_B \quad \text{and} \quad d_D = d_E - (d_B - d_C)$$

Since the number of teeth are proportional to their pitch circle diameters for the same module, therefore

$$T_E = T_A + 2T_B \qquad T_D = T_E - (T_B - T_C)$$

$$\therefore T_E = 12 + 2 \times 30 \qquad \therefore T_D = 72 - (30 - 14)$$

$$\boxed{\therefore T_E = 72} \qquad \boxed{\therefore T_D = 56}$$

Magnitude and direction of angular velocities of arm OP and wheel

The table of motions is drawn as follows:

Sr. No.	Condition of motion	Revolutions of elements				
		Arm	Wheel A	Compound wheel B-C	Wheel D	Wheel E
1	Arm fixe, gear A rotates -1 revolution(clockwise)	0	-1	$+\frac{T_A}{T_B}$	$+\frac{T_A}{T_B} \times \frac{T_C}{T_D}$	$+\frac{T_A}{T_B} \times \frac{T_B}{T_E} = +\frac{T_A}{T_E}$
2	Arm fixed gear A rotates through - x revolutions	0	-x	$+x \frac{T_A}{T_B}$	$+x \frac{T_A}{T_B} \times \frac{T_C}{T_D}$	$+x \frac{T_A}{T_E}$
3	Add - y revolutions to all elements	-y	-y	-y	-y	-y
4	Total motion	-y	-x-y	$x \frac{T_A}{T_B} - y$	$x \frac{T_A}{T_B} \times \frac{T_C}{T_D} - y$	$x \frac{T_A}{T_E} - y$

Since the wheel A makes 1 r.p.s. clockwise, therefore from the fourth row of the table,

$$-x - y = -1$$

$$\therefore x + y = 1 \quad (1)$$

Also, the wheel D makes 5 r.p.s. counter clockwise, therefore

$$x \frac{T_A}{T_B} \times \frac{T_C}{T_D} - y = 5$$

$$\therefore x \frac{T_B}{T_A} \times \frac{T_D}{T_C} - y = 5$$

$$\therefore x \frac{12}{30} \times \frac{14}{56} - y = 5$$

$$\therefore 0.1x - y = 5 \quad (2)$$

From equations (1) and (2),

$$x = 5.45 \quad \text{and} \quad y = -4.45$$

Angular velocity of arm OP

$$= -y = -(-4.45) = 4.45 \text{ r.p.s}$$

$$= 4.45 \times 2\pi = 27.964 \text{ rad/sec (Anti clockwise)}$$

And angular velocity of wheel E

$$= x \frac{T_A}{y T_E}$$

$$= 5.45 \times \frac{12}{72} - (-4.45)$$

$$= 5.36 \text{ r.p.s}$$

$$= 5.36 \times 2\pi$$

$$= 33.68 \text{ rad/sec (Anti)}$$

Example 6.17. Fig shows an epicyclic gear train known as Ferguson's paradox. Gear A is fixed to the frame and is, therefore, stationary. The arm B and gears C and D are free to rotate on the shaft S . Gears A , C and D have 100, 101 and 99 teeth respectively. The planet gear has 20 teeth. The pitch circle diameters of all are the same so that the planet gear P meshes with all of them. Determine the revolutions of gears C and D for one revolution of the arm B .

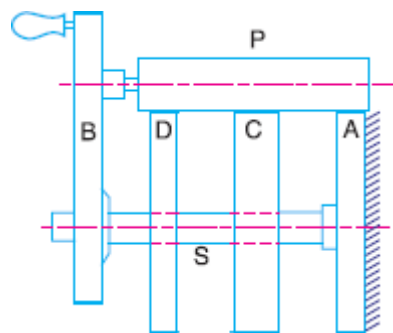

Fig. 6.17

Solution:

$$\text{Given : } T_A = 100 ; T_C = 101 ; T_D = 99 ; T_P = 20$$

The table of motions is given below:

Sr. No.	Condition of motion	Revolutions of elements			
		Arm B	Gear A	Gear C	Gear D
1	Arm B fixe, gear A rotates +1 revolution(anticlockwise)	0	+1	$+\frac{T_A}{T_C}$	$+\frac{T_A}{T_C} \times \frac{T_C}{T_D} = \frac{T_A}{T_D}$
2	Arm B fixed gear A rotates through + x revolutions	0	+x	$+\frac{x T_A}{T_C}$	$x \frac{T_A}{T_D}$
3	Add + y revolutions to all elements	+ y	+ y	+ y	+ y
4	Total motion	+ y	x + y	$y + x \frac{T_A}{T_C}$	$y + x \frac{T_A}{T_D}$

The arm B makes one revolution, therefore

$$y = 1$$

Since the gear A is fixed, therefore from the fourth row of the table,

$$x + y = 0$$

$$\therefore x = -y = -1$$

Let N_C and N_D = Revolutions of gears C and D respectively.

From the fourth row of the table, the revolutions of gear C,

$$\begin{aligned} N_C &= y + x \frac{T_A}{T_C} \\ &= 1 - 1 \times \frac{100}{101} \end{aligned}$$

$$\therefore N_C = +\frac{1}{101}$$

And the revolutions of gear D,

$$N_D = y + x \frac{T_A}{T_D} = 1 - \frac{100}{99}$$

$$\therefore N_D = -\frac{1}{99}$$

From above we see that for one revolution of the arm B, the gear C rotates through 1/101 Revolution in the same direction and the gear D rotates through 1/99 revolutions in the opposite direction.

Example 6.18. Fig. shows an epicyclic gear train. Pinion A has 15 teeth and is rigidly fixed to the motor shaft. The wheel B has 20 teeth and gears with A and also with the annular

fixed wheel E. Pinion C has 15 teeth and is integral with B (B, C being a compound gear wheel). Gear C meshes with annular wheel D, which is keyed to the machine shaft. The arm rotates about the same shaft on which A is fixed and carries the compound wheel B,

C. If the motor runs at 1000 r.p.m., find the speed of the machine shaft. Find the torque exerted on the machine shaft, if the motor develops a torque of 100 N-m.

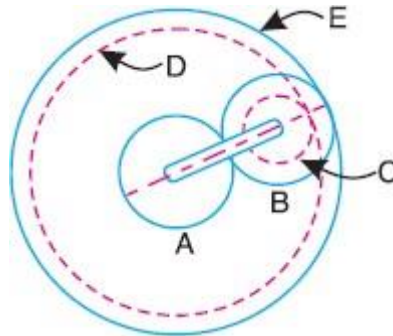

Fig. 6.18

Solution:

Given : $T_A = 15$; $T_B = 20$; $T_C = 15$; $N_A = 1000$ r.p.m.;

Torque developed by motor (or pinion A) = 100 N-m

1. Speed of the machine shaft

The table of motions is given below:

Sr. No.	Condition of motion	Revolution of element				
		Arm	Pinion A	Compound wheel D-C	Wheel D	Wheel E
1	Arm fixed, gear A rotates +1 revolution (anticlockwise)	0	+1	$-\frac{T_A}{T_B}$	$-\frac{T_A}{T_B} \times \frac{T_C}{T_D}$	$-\frac{T_A}{T_B} \times \frac{T_B}{T_E} = -\frac{T_A}{T_E}$
2	Arm fixed gear A rotates through +x revolutions	0	+x	$-x \frac{T_A}{T_B}$	$-x \frac{T_A}{T_B} \times \frac{T_C}{T_D}$	$-x \frac{T_A}{T_E}$
3	Add +y revolutions to all elements	+y	+y	+y	+y	+y
4	Total motion	+y	x+y	$y - x \frac{T_A}{T_B}$	$y - x \frac{T_A}{T_B} \times \frac{T_C}{T_D}$	$y - x \frac{T_A}{T_E}$

First of all, let us find the number of teeth on wheels D and E. Let T_D and T_E be the number of teeth on wheels D and E respectively. Let d_A , d_B , d_C , d_D and d_E be the pitch circle diameters of wheels A, B, C, D and E respectively. From the geometry of the figure,

$$d_E = d_A + 2d_B \quad \text{and} \quad d_D = d_E - (d_B - d_C)$$

Since the number of teeth are proportional to their pitch circle diameters, therefore,

$$T_E = T_A + 2 T_B = 15 + 2 \times 20 = 55$$

$$T_D = T_E - (T_B - T_C) = 55 - (20 - 15) = 50$$

We know that the speed of the motor or the speed of the pinion A is 1000 r.p.m.

Therefore

$$x + y = 1000 \quad \dots(1)$$

Also, the annular wheel E is fixed, therefore

$$y - x \frac{T_A}{T_E} = 0$$

$$\therefore y = x \frac{T_A}{T_E}$$

$$\therefore y = x \frac{15}{55}$$

$$\therefore y = 0.273x \quad \dots(2)$$

From equations (1) and (2),

$$x = 786 \quad \text{and} \quad y = 214$$

\therefore Speed of machine shaft = Speed of wheel D

$$\begin{aligned} N_D &= y - x \frac{T_A}{T_B} \times \frac{T_C}{T_D} \\ &= 214 - 786 \times \frac{15}{20} \times \frac{15}{50} \\ &= + 37.15 \text{ r.p.m.} \end{aligned}$$

$$\therefore N_D = 37.15$$

Torque exerted on the machine shaft

We know that

Torque developed by motor \times Angular speed of motor

= Torque exerted on machine shaft \times Angular speed of machine shaft

$$\therefore 100 \times \omega_A = \text{Torque exerted on machine shaft} \times \omega_D$$

$$\begin{aligned} \therefore \text{Torque exerted on machine shaft} &= 100 \times \frac{\omega_A}{\omega_D} \\ &= 100 \times \frac{N_A}{N_D} = 100 \times \frac{1000}{37.5} \end{aligned}$$

$$\therefore \text{Torque exerted on machine shaft} = 2692 \text{ N}\cdot\text{m}$$

Example 6.19. An epicyclic gear train consists of a sun wheel S , a stationary internal gear E and three identical planet wheels P carried on a star-shaped planet carrier C . The sizes of different toothed wheels are such that the planet carrier C rotates at 1/5th of the speed of the sun wheel S . The minimum number of teeth on any wheel is 16. The driving torque on

the sun wheel is 100 N-m. Determine: 1. Number of teeth on different wheels of the train, and 2. torque necessary to keep the internal gear stationary.

Solution:

$$\text{Given } N = \frac{N_s}{5}$$

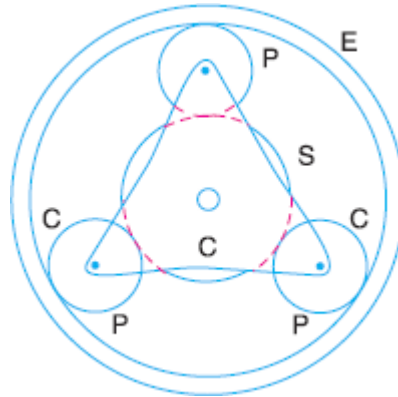

Fig. 6.19

1. Number of teeth on different wheels

The arrangement of the epicyclic gear train is shown in Fig.. Let T_S and T_E be the number of teeth on the sun wheel S and the internal gear E respectively. The table of motions is given below:

Sr. No.	Conditions of motion	Revolutions of elements			
		Plant carrier C	Sun wheel S	Planet Wheel P	Internal Gear E
1	Planet carrier C fixed, sun wheel S rotates through + 1 revolution (anticlockwise)	0	+1	$-\frac{T_S}{T_P}$	$-\frac{T_S}{T_P} \times \frac{T_P}{T_E} = -\frac{T_S}{T_E}$
2	Planet carrier C fixed, sun wheel S rotates through + x revolutions	0	+ x	$-x \frac{T_S}{T_P}$	$-x \frac{T_S}{T_E}$
3	Add + y revolutions to all elements	+ y	+ y	+ y	+ y
4	Total motion	+ y	+ $x + y$	$y - x \frac{T_S}{T_P}$	$y - x \frac{T_S}{T_E}$

We know that when the sun wheel S makes 5 revolutions, the planet carrier C makes 1 revolution. Therefore from the fourth row of the table,

$$y = 1, \quad \text{and} \quad x + y = 5$$

$$\therefore x = 4$$

Since the gear E is stationary, therefore from the fourth row of the table,

$$y - x \frac{T_S}{T_E} = 0$$

$$\therefore 1 - 4 \frac{T_S}{T_E} = 0$$

$$\therefore T_E = 4T_S$$

Since the minimum number of teeth on any wheel is 16, therefore let us take the number of teeth on sun wheel,

$$T_S = 16$$

$$\therefore T_E = 4 \times 16 = 64$$

Let d_S , d_P and d_E be the pitch circle diameters of wheels S , P and E respectively. Now from the geometry of Fig

$$d_S + 2 d_P = d_E$$

Assuming the module of all the gears to be same, the number of teeth are proportional to their pitch circle diameters.

$$T_S + 2 T_P = T_E$$

$$\therefore 16 + 2T_P = 64$$

$$\therefore T_P = 24$$

2. Torque necessary to keep the internal gear stationary

We know that

Torque on $S \times$ Angular speed of $S =$ Torque on $C \times$ Angular speed of C

$$100 \times \omega_S = \text{Torque on } C \times \omega_C$$

$$\therefore \text{Torque on } C = 100 \times \frac{\omega_S}{\omega_C}$$

$$= 100 \times \frac{N_S}{N_C}$$

$$= 100 \times 5$$

$$\therefore \text{Torque on } C = 500 \text{ N}\cdot\text{m}$$

\therefore Torque necessary to keep the internal gear stationary

$$= 500 - 100$$

$$= 400 \text{ N}\cdot\text{m}$$

References

1. Theory of Machines by S.S.Rattan, Tata McGraw Hill
 2. Theory of Machines by R.S. Khurmi & J.K.Gupta,S.Chand
 3. Theory of machines and mechanisms by P.L.Ballaney by Khanna Publishers
-

Question Bank

Unit I

1. What is meant by inversion of a mechanism? Describe with the help of suitable sketches the inversion of (a) Slider crank chain and (b) double slider chain. What are the different forms of quadric cycle chain?
2. What is a Kinematic pair? State different methods of classifying them and state the salient features of each method of classification
3. What is the difference between quick return motion of crank and slotted lever type and that of Whitworth type? What is the ratio of time taken on cutting and return strokes?
4. What are resistant bodies? Is it necessary that the resistant bodies be rigid? Give reasons for your answer.(b) Describe elliptical trammels. How does it enable you to describe a true ellipse?
5. Using kutzbach Criterion, find the number of degrees of freedom of the two mechanisms M1 & M2 shown below.

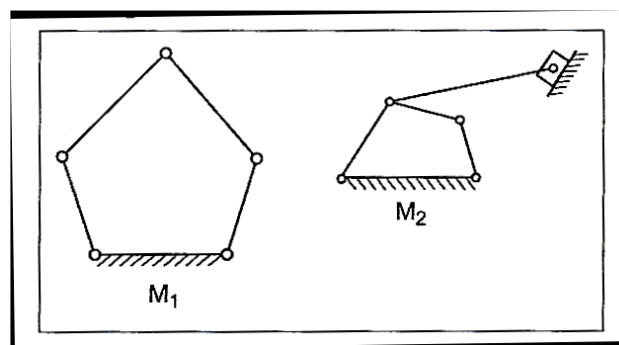

Unit II

1. a) Prove that the tracing point, giving the horizontal straight line motion in Tchebicheff mechanism, lies at the midpoint of the coupler.
b) Prove that a point on one of links of a Hart mechanism traces a straight line on the movement of its links?
2. a) Under what conditions Scott-Russell mechanism traces out a straight line and an ellipse? State the limitations of Scott-Russell mechanism.
b) Sketch a pantograph, explain its working and show that it can be used to reproduce to an enlarged scale a given figure.
3. a) Show that the Peaucellier mechanism generates an exact straight line as its path.
b) A circle has OR as its diameter and a point Q lies on its circumference. Another point P lies on the line OQ produced. If OQ turns about O as centre and the product $OQ \times OP$ remains constant, show that the point P moves along a straight line perpendicular to the diameter OR.
4. a) Sketch a Peaucellier mechanism. Show that it can be used to trace a straight line.
b) How can you show that a Watt mechanism traces an approximate straight line?
5. An Ackermann steering gear does not satisfy the fundamental equation of steering gear at all positions. Yet it is widely used. Why?
6. Two shafts are to be connected by a Hooke's joint. The driving shaft rotates at a uniform speed of 500 rpm and the speed of the driven shaft must lie between 475 and 525 rpm. Determine the maximum permissible angle between the shafts.

7. In a Whitworth quick return motion, a crank AB rotates about the fixed centre A. The end B operates a slider reciprocating in a slotted link, rotating about a fixed centre D, 5 cm vertically above A. The crank AB which is 10 cm long, rotates in a clockwise direction at a speed of 100 r.p.m. Find the angular acceleration of the slotted link for the configuration in which AB has turned through an angle of 45 degrees past its lowest position.
8. Derive an expression for the ratio of angular velocities of the shafts of a Hooke's joint.
9. Using Davis steering gear, find the inclination of the track arms to the longitudinal axis of the car if the length of car between axles is 2.3 m, and the steering pivots are 1.3 m apart. The car is moving in a straight path.
10. What conditions must be satisfied by the steering mechanism of a car in order that the wheels may have a pure rolling motion when rounding a curve? Deduce the relationship connecting the inclinations of the front stub axles to the rear axle, the distance between the pivot centres for the front axles and wheel base of the car.

Unit III

1. State and prove the Kennedy's theorem as applicable to instantaneous centres of rotation of three bodies. How is it helpful in locating various instantaneous centres of a mechanism?
2. In a four bar chain ABCD, AD is the fixed link 12 cm long, crank AB is 3 cm long and rotates uniformly at 100 r.p.m. clockwise while the link CD is 6 cm long and oscillates about D. Link BC is equal to link AD. Find the angular velocity of link DC when angle BAD is 60°.
3. Refer to Figure.1. The following dimensions are given. $O_2A = 4\text{cm}$, $AB = 7\text{cm}$, $AO_2B = 450$, $\omega_2 = 25\text{ rad/s cw}$. Determine the angular velocity of the connecting rod and velocity of piston. Also, determine the velocity of the center of gravity of the connecting rod which is at a distance of 3 cm from the crank pin A. Use the Instantaneous center method.

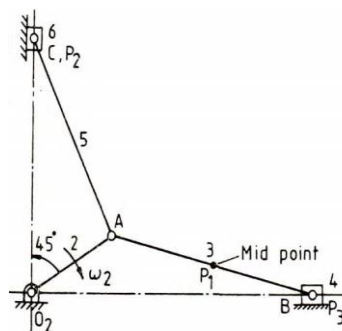

4. In a four link mechanism, the dimensions of links are as under; $AB=50\text{ mm}$; $BC=66\text{ mm}$; $CD=56\text{ mm}$ and $AD=100\text{ mm}$. At the instant when $\angle DAB=60^\circ$, the link 'AB' has angular Velocity of 10.5 rad/Sec in counter clock wise direction and has a retardation of 26 rad/Sec . Determine
 - (i) Velocity of point 'C'.
 - (ii) Velocity of point 'E' on link 'BC' when $BE=40\text{ mm}$.
 - (iii) Angular Velocities of link 'BC' and 'CD'.
 - (iv) Velocity of an offset point 'F' on link 'BC' if $BF=45\text{ mm}$, $CF=30\text{ mm}$ and BCF is read clock wise.

- (v) Velocity of an offset point 'G' on link 'CD' if $CG=24$ mm, $DG=44$ mm and DCG is read clock wise.
 (vi) Velocity of rubbing at pins A, B, C and D when rods of pins are 30, 40, 25 and 35 mm respectively.
 (vii) Angular acceleration of links 'BC' and 'CD'.
 (viii) Linear acceleration of points 'E', 'F' and 'G'.

5. An engine crank shaft drives a retroaction pump through a mechanism a shown in fig. The crank rotates at 160 rpm in clock wise direction diameter of pump piston at 'F' is 200 mm, Dimensions of various link are $OA=170$ mm, $AB=660$, $BC=510$ mm, $CD=170$ mm, $DE=830$ mm for the position of crank shown in diagram determine.

- (i) Velocity of cross head at E.
 (ii) Velocity of rubbing at ins A,B,C & D, the diameters being 40,30,30 and 50 mm respectively.
 (iii) Forque required at shaft 'O' to overcome a pressure of 300 km/m^2 at pump piston 'F'.

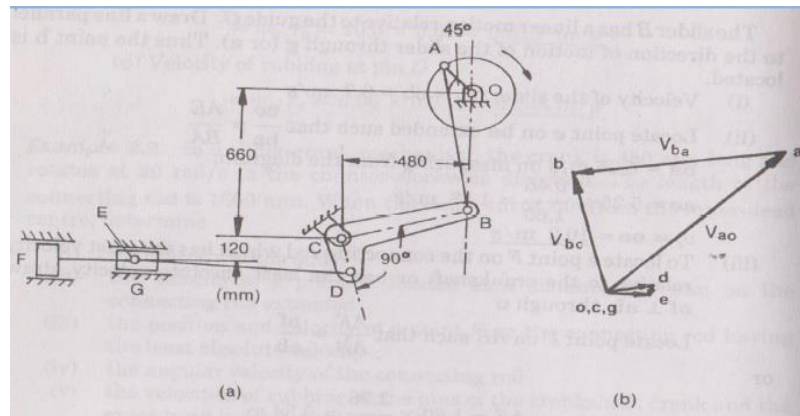

6. For the crank slotted lever mechanism shown in fig. determine acceleration of ram 'D' of crank rotates at 120 rpm in anti clock wise direction. Also determine angular acceleration of slotted link given $AB=150$ mm, slotted are $OC=700$ mm, link $CD=200$ mm.

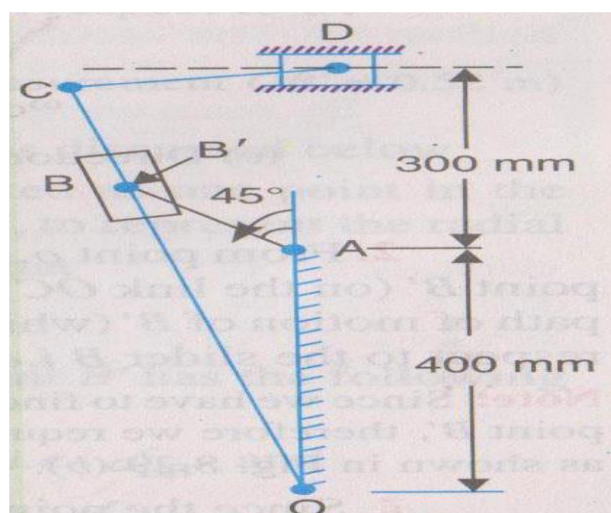

Unit IV

- Explain the procedure to layout the cam profile for a reciprocating follower.
 - Derive relations for velocity and acceleration for a convex cam with a flat faced follower

2. Draw a cam profile which would impart motion to a flat faced follower in the following desired way. The stroke of the follower being 5 cm. (i) The follower to move with uniform acceleration upward for 900°, dwell for next 900°, (ii) The follower to return downward with uniform retardation for 1200° and dwell for next 600°. The minimum radius of the cam being 3 cm.
3. Compare the performance of Knife –edge, roller and mushroom followers.
 - (b) A knife edged follower for the fuel valve of a four stroke diesel engine has its centre line coincident with the vertical centre line of the cam. It rises 2.5 cm with SHM during 600° rotation of cam, then dwells for 200° rotation of cam and finally descends with uniform acceleration and deceleration during 450° rotation of cam, the deceleration period being half the acceleration period. The least radius of the cam is 5 cm. Draw the profile of the cam to full size.
4. A cam profile consists of two circular arcs of radii 24 mm and 12 mm joined by straight lines giving the follower a lift of 12 mm. The follower is a roller of 24 mm radius and its line of action is a straight line passing through the cam shaft axis. When the cam shaft has a uniform speed of 500 r.p.m., find the maximum velocity and acceleration of the follower while in contact with the straight flank of the cam.
5. A cam with 30mm as minimum diameter is rotating clockwise at a uniform speed of 1200rpm and has to give the following motion to a roller follower 10mm in diameter:
 - (i) Follower to complete outward stroke of 25mm during 120° of cam rotation with equal uniform acceleration and retardation.
 - (ii) Follower to dwell for 60° of cam rotation.
 - (iii) Follower to return to its initial position during 90° of cam rotation with equal uniform acceleration and retardation.
 - (iv) Follower to dwell for remaining 90° of cam rotation.
 Draw the cam profile if the axis of the roller follower passes through the axis of the cam.
6. Draw the cam profile for the following data: Basic circle radius of cam = 50mm, Lift = 40mm, Angle of ascent with cycloidal = 60°, angle of dwell = 90°, angle of descent with uniform velocity = 90°, speed of cam = 300rpm, Follower offset = 10mm, Type of follower = knife – Edge.
7. Draw the cam profile for the following data:

Basic circle radius of cam = 50mm, Lift = 40mm, Angle of ascent with SHM = 90°, Angle of Dwell = 90°, Angle of descent with uniform acceleration and deceleration = 90°, speed of cam = 300 rpm, Type of follower = Roller follower (With roller radius = 10mm).

Unit V

1. a) Make a comparison of cycloidal and involute tooth forms. b) Two 200 pressure angle involute gears in mesh have a module of 10mm. Addendum is 1 module. Large gear has 50 teeth and the pinion has 13 teeth. Does interference occur? If it occurs, to what value should the pressure angle be changed to eliminate interference?
 2. Sketch two teeth of a gear and show the following: face, flank, top land, bottom land, addendum, dedendum, tooth thickness, space width, face width and circular pitch.
 - (b) Derive a relation for minimum number of teeth on the gear wheel and the pinion to avoid interference
-

3. Two gears in mesh have a module of 10 mm and a pressure angle of 25° . The pinion has 20 teeth and the gear has 52. The addendum on both the gears is equal to one module. Determine (i) The number of pairs of teeth in contact (ii) The angles of action of the pinion and the wheel (iii) The ratio of the sliding velocity to the rolling velocity at the pitch point and at the beginning and end of engagement.
4. What is a worm and worm wheel? Where is it used?
 (b) Two 200 involute spur gears mesh externally and give a velocity ratio of 3. Module is 3 mm and the addendum is equal to 1.1 module. If the pinion rotates at 120 r.p.m. find: (i) The minimum number of teeth on each wheel to avoid interference. (ii) The number of pairs of teeth in contact
5. Two involute gears of 20° pressure angle are in mesh. The number of teeth on pinion is 20 and the gear ratio is 2. If the pitch expressed in module is 5 mm, and the pitch line speed is 1.2 m/s, assuming addendum as standard and equal to one module, find (i) the angle turned through by pinion when one pair of teeth is in mesh; and (ii) the maximum velocity of sliding
6. An epicyclic gear train shown in figure below.

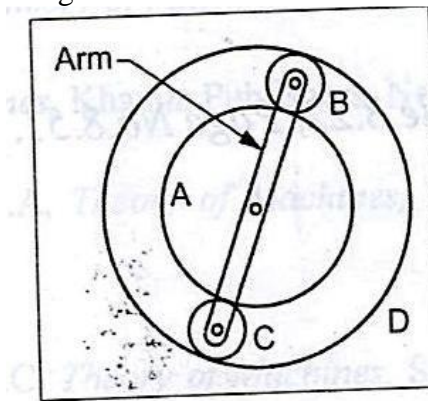

- The internal gear D has 90 teeth and the sun gear A has 40 teeth. The two planet gears B & C are identical and they are attached to an arm as shown. How many revolutions does the arm makes, (i) When 'A' makes one revolution in clockwise and 'D', makes one revolution in clockwise and 'D' makes $\frac{1}{2}$ revolutions in opposite sense.
 (ii) When 'A' makes one revolution in clockwise and 'D' remains stationary.
7. Two mating gears have 20 and 40 involute teeth of module 10mm and 20° pressure angle. The addendum on each wheel is to be made of such a length that the line of contact on each side of the pitch point has half of the maximum possible length. Determine the addendum height for each gear wheel, length of the path of contact, arc of contact and contact ratio.
-

KOM-Group Project

1. Development of air compressor using crank and slotted link mechanism
 2. Design and analysis of scott-russell's straight-line mechanism using solid works
 3. Design and development of double acting hacksaw using scotch yoke mechanism
 4. Design, fabrication and analysis of four bar walking machine based on chebyshev's parallel motion mechanism
 5. Analysis of radial cam with roller follower
 6. Design and analysis of an epicyclic gear train mechanism
 7. Study and sectional view of differential gear
 8. Kinematic design and fabrication of four bar mechanism to steer a human-powered vehicle
 9. Slider-crank mechanism for demonstration and experimentation
-