

COURSE MATERIAL

II Year B. Tech I- Semester
MECHANICAL ENGINEERING

AY: 2024-25



Materials Engineering

R22A0305



Prepared by:
Dr. Srikar Potnuru
Assoc. Professor

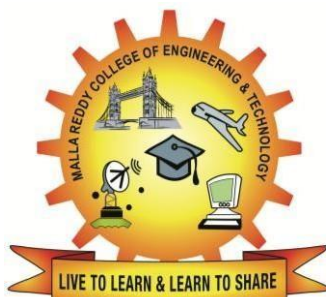

MALLA REDDY COLLEGE OF ENGINEERING & TECHNOLOGY

DEPARTMENT OF MECHANICAL ENGINEERING

(Autonomous Institution-UGC, Govt. of India)
Secunderabad-500100, Telangana State, India.

www.mrcet.ac.in

MALLA REDDY COLLEGE OF ENGINEERING AND TECHNOLOGY

II Year B.Tech. ME- I Sem

L/T/P/C
3/-/-/3**(R22A0305) Materials Engineering****COURSE OBJECTIVES:**

1. To understand the basic structure, properties of metals, mechanism of crystallization and imperfections in crystals.
2. To study the importance of binary phase diagrams.
3. To acquire knowledge on properties and structure of ferrous and nonferrous alloys and to select suitable materials for various engineering applications.
4. To learn various methods of heat treatment processes.
5. To gain knowledge on advanced materials and concepts of metallurgy.

UNIT I

Structure of Metals: Bonds in Solids – Metallic bond - crystallization of metals, imperfections, grain and grain boundaries, effect of grain boundaries on the properties of metal / alloys – determination of grain size.

Constitution of Alloys: Necessity of alloying, types of solid solutions, Hume Rotherys rules, intermediate alloy phases, and electron compounds.

UNIT II**Equilibrium Diagrams**

Experimental methods of construction of equilibrium diagrams, Isomorphous alloy systems, equilibrium cooling and heating of alloys, Lever rule, eutectic systems, congruent melting intermediate phases, peritectic reaction. Transformations in the solid state, allotropy, eutectoid, peritectoid reactions, phase rule, relationship between equilibrium diagrams and properties of alloys. Study of binary phase diagram of Fe-Fe₃C.

UNIT III

Cast Iron & Steel: Structure and properties of White Cast iron, Malleable Cast iron, Grey cast iron, Spheroidal graphite cast iron, Alloy cast irons. Classification of steels, structure and properties of plain carbon steels, Low alloy steels, Had field manganese steels, tool and die steels.

Nonferrous metals & Alloys: Structure and properties of copper and its alloys, Aluminium and its alloys, Titanium and its alloys.

UNIT IV

Heat treatment of Alloys: Effect of alloying elements on Iron – Iron carbon system, Annealing, normalizing, Hardening, TTT diagrams, tempering, Harden ability, surface - hardening methods, Age hardening

Ceramic Materials: Crystalline ceramics, glasses, cermets.

UNIT V

Composite Materials: Classification of composites, various methods of component manufacture of composites, particle – reinforced materials, fiber reinforced materials, metal ceramic mixtures, metal – matrix composites and Carbon– Carbon composites.

Metallurgy: Steel Making - Introduction, Methods of steelmaking – crucible process, Bessemer converter process, Open Hearth Process, Introduction to Powder metallurgy.

TEXT BOOKS:

1. Kodgire, Material Science and Metallurgy, 42nd edition Everest Publishing House 2017.
2. Donald R. Askeland, Essential of Materials Science and Engineering. Thomson Publications 2014.
3. V. Raghavan, Material Science and Engineering, Prentice –Hall of India Pvt. Ltd., 2007
4. Sidney H. Avner, Introduction to physical metallurgy, Tata Mc-Graw-Hill, Inc. 1997.

REFERENCES:

1. Sidney H. Avener, Introduction to Physical Metallurgy, TMH
2. William and collister, Materials Science and Engineering, wiley pub. 2014.
3. V. Raghavan, Material science and engineering, PH Pub. 2015.
4. R.K. Rajput, Engineering materials and metallurgy. S.Chand & Co. 2006.
5. O.P. Khanna, Material Science and Metallurgy. Dhanpatrai Pub. 2014

COURSE OUTCOMES:

1. Understand the mechanism of crystallization, methods of determining grain size and factors affecting the solid solubility.
2. Use the phase diagrams of binary systems and iron-carbide diagram to select the material composition.
3. Understand the structure and properties of various cast irons, steels and nonferrous alloys.
4. Apply the various heat treatment processes, TTT diagram, surface hardening methods & coatings depending on material requirements.
5. Understand the importance of ceramics, composites and concepts of metallurgy

Materials Engineering

Chapter 1. Introduction

1.1 Historical Perspective and Materials Science

1.1.1 Historical Perspective

Materials are so important in the development of human civilization that the historians have identified early periods of civilization by the name of most significantly used material, e.g.: Stone Age, Bronze Age. This is just an observation made to showcase the importance of materials and their impact on human civilization. It is obvious that materials have affected and controlling a broad range of human activities through thousands of decades.

From the historical point of view, it can be said that human civilization started with *Stone Age* where people used only natural materials, like stone, clay, skin, and wood for the purposes like to make weapons, instruments, shelter, etc. Thus the sites of deposits for better quality stones became early colonies of human civilization. However, the increasing need for better quality tools brought forth exploration that led to *Bronze Age*, followed by *Iron Age*. When people found copper and how to make it harder by alloying, the *Bronze Age* started about 3000 BC. The use of iron and steel, a stronger material that gave advantage in wars started at about 1200 BC. Iron was abundant and thus availability is not limited to the affluent. This commonness of the material affected every person in many aspects, gaining the name *democratic material*. The next big step in human civilization was the discovery of a cheap process to make steel around 1850 AD, which enabled the railroads and the building of the modern infrastructure of the industrial world. One of the most significant features of the *democratic material* is that number of users just exploded. Thus there has been a need for human and material resources for centuries, which still going strong. It's being said and agreed that we are presently in *Space Age* marked by many technological developments towards development materials resulting in

stronger and light materials like composites, electronic materials like semiconductors, materials for space voyage like high temperature ceramics, biomaterials, etc.

In summary, materials constitute foundation of technology. The history of human civilization evolved from the Stone Age to the Bronze Age, the Iron Age, the Steel Age, and to the Space Age (contemporaneous with the Electronic Age). Each age is marked by the advent of certain materials. The Iron Age brought tools and utensils. The Steel Age brought railroads, instruments, and the Industrial Revolution. The Space Age brought the materials for stronger and light structures (e.g., composite materials). The Electronic Age brought semiconductors, and thus many varieties of electronic gadgets.

1.1.2 Materials Science

As engineering materials constitute foundation of technology, it's not only necessary but a must to understand how materials behave like they do and why they differ in properties. This is only possible with the atomistic understanding allowed by quantum mechanics that first explained atoms and then solids starting in the 1930s. The combination of physics, chemistry, and the focus on the relationship between the properties of a material and its microstructure is the domain of Materials Science. The development of this science allowed designing materials and provided a knowledge base for the engineering applications (Materials Engineering).

Important components of the subject Materials Science are structure, properties, processing, and performance. A schematic interrelation between these four components is shown in figure 1.1.

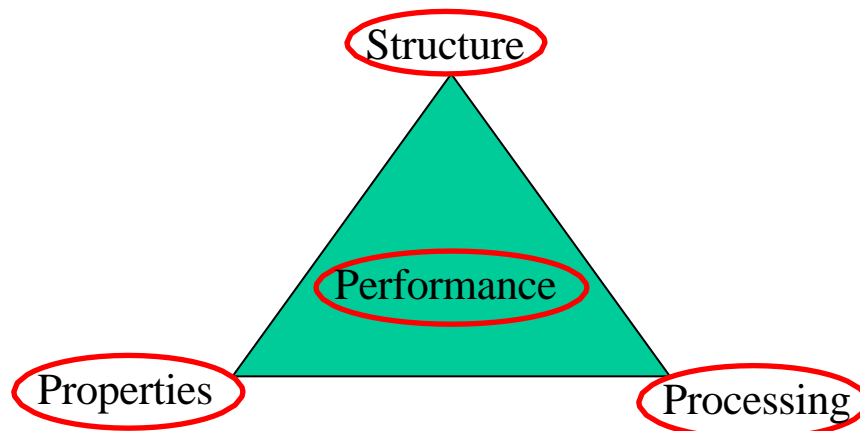

Figure 1.1: *Interrelation between four components of Materials Science.*

1.2 Why Study Materials Science and Engineering? and Classification of Materials?

1.2.1 Why Study Materials Science and Engineering?

All engineers need to know about materials. Even the most "immaterial", like software or system engineering depend on the development of new materials, which in turn alter the economics, like software-hardware trade-offs. Increasing applications of system engineering are in materials manufacturing (industrial engineering) and complex environmental systems.

Innovation in engineering often means the clever use of a new material for a specific application. For example: plastic containers in place of age-old metallic containers. It is well learnt lesson that engineering disasters are frequently caused by the misuse of materials. So it is vital that the professional engineer should know how to select materials which best fit the demands of the design - economic and aesthetic demands, as well as demands of strength and durability. Beforehand the designer must understand the properties of materials, and their limitations. Thus it is very important that every engineer must study and understand the concepts of Materials Science and Engineering. This enables the engineer

- To select a material for a given use based on considerations of cost and performance.
- To understand the limits of materials and the change of their properties with use.
- To be able to create a new material that will have some desirable properties.
- To be able to use the material for different application.

1.2.2 Classification of Materials

Like many other things, materials are classified in groups, so that our brain can handle the complexity. One can classify them based on many criteria, for example crystal structure (arrangement of atoms and bonds between them), or properties, or use. Metals, Ceramics, Polymers, Composites, Semiconductors, and Biomaterials constitute the main classes of present engineering materials.

Metals: These materials are characterized by high thermal and electrical conductivity; strong yet deformable under applied mechanical loads; opaque to light (shiny if polished). These characteristics are due to valence electrons that are detached from atoms, and spread in an *electron sea* that *glues* the ions together, i.e. atoms are bound together by metallic bonds and weaker van der Waalls forces. Pure metals are not good enough for many applications, especially structural applications. Thus metals are used in alloy form i.e. a metal mixed with another metal to improve the desired qualities. E.g.: aluminum, steel, brass, gold.

Ceramics: These are inorganic compounds, and usually made either of oxides, carbides, nitrides, or silicates of metals. Ceramics are typically partly crystalline and partly amorphous. Atoms (ions often) in ceramic materials behave mostly like either positive or negative ions, and are bound by very strong Coulomb forces between them. These materials are characterized by very high strength under compression, low ductility; usually insulators to heat and electricity. Examples: glass, porcelain, many minerals.

Polymers: Polymers in the form of thermo-plastics (nylon, polyethylene, polyvinyl chloride, rubber, etc.) consist of molecules that have covalent bonding within each molecule and van der Waals forces between them. Polymers in the form of thermo-sets (e.g., epoxy, phenolics, etc.) consist of a network of covalent bonds. They are based on H, C and other non-metallic elements. Polymers are amorphous, except for a minority of thermoplastics. Due to the kind of bonding, polymers are typically electrical and thermal insulators. However, conducting polymers can be obtained by doping, and conducting polymer-matrix composites can be obtained by the use of conducting fillers. They decompose at moderate temperatures (100 – 400 C), and are lightweight. Other properties vary greatly.

Composite materials: Composite materials are multiphase materials obtained by artificial combination of different materials to attain properties that the individual components cannot attain. An example is a lightweight brake disc obtained by embedding SiC particles in Al-alloy matrix. Another example is reinforced cement concrete, a structural composite obtained by combining cement (the matrix, i.e., the binder, obtained by a reaction known as hydration, between cement and water), sand (fine aggregate), gravel (coarse aggregate), and, thick steel fibers. However, there are some natural composites available in nature, for example – wood. In general, composites are classified according to their matrix materials. The main classes of composites are metal-matrix, polymer-matrix, and ceramic-matrix.

Semiconductors: Semiconductors are covalent in nature. Their atomic structure is characterized by the highest occupied energy band (the valence band, where the valence electrons reside energetically) full such that the energy gap between the top of the valence band and the bottom of the empty energy band (the conduction band) is small enough for some fraction of the valence electrons to be excited from the valence band to the conduction band by thermal, optical, or other forms of energy. Their electrical properties depend extremely strongly on minute proportions of contaminants. They are usually doped in order to enhance electrical conductivity. They are used in the form of single crystals without dislocations because grain boundaries and dislocations would degrade electrical behavior. They are opaque to visible light but transparent to the infrared. Examples: silicon (Si), germanium (Ge), and gallium arsenide (GaAs, a compound semiconductor).

Biomaterials: These are any type material that can be used for replacement of damaged or diseased human body parts. Primary requirement of these materials is that they must be biocompatible with body tissues, and must not produce toxic substances. Other important material factors are: ability to support forces; low friction, wear, density, and cost; reproducibility. Typical applications involve heart valves, hip joints, dental implants, intraocular lenses. Examples: Stainless steel, Co-28Cr-6Mo, Ti-6Al-4V, ultra high molecular weight poly-ethelene, high purity dense Al-oxide, etc.

1.3 Advanced Materials, Future Materials, and Modern Materials needs

1.3.1 Advanced Materials

These are materials used in *High-Tech* devices those operate based on relatively intricate and sophisticated principles (e.g. computers, air/space-crafts, electronic gadgets, etc.). These materials are either traditional materials with enhanced properties or newly developed materials with high-performance capabilities. Hence these are relatively expensive. Typical applications: integrated circuits, lasers, LCDs, fiber optics, thermal protection for space shuttle, etc. Examples: Metallic foams, inter-metallic compounds, multi-component alloys, magnetic alloys, special ceramics and high temperature materials, etc.

1.3.2 Future Materials

Group of new and state-of-the-art materials now being developed, and expected to have significant influence on present-day technologies, especially in the fields of medicine, manufacturing and defense. Smart/Intelligent material system consists some type of sensor (*detects an input*) and an actuator (*performs responsive and adaptive function*). Actuators may be called upon to change shape, position, natural frequency, mechanical characteristics in response to changes in temperature, electric/magnetic fields, moisture, pH, etc.

Four types of materials used as actuators: Shape memory alloys, Piezo-electric ceramics, Magnetostrictive materials, Electro-/Magneto-rheological fluids. Materials / Devices used as sensors: Optical fibers, Piezo-electric materials, Micro-electro-mechanical systems (MEMS), etc.

Typical applications: By incorporating sensors, actuators and chip processors into system, researchers are able to stimulate biological human-like behavior; Fibers for bridges, buildings, and wood utility poles; They also help in fast moving and accurate robot parts, high speed helicopter rotor blades; Actuators that control chatter in precision machine tools; Small microelectronic circuits in machines ranging from computers to photolithography prints; Health monitoring detecting the success or failure of a product.

1.3.3 Modern Materials needs

Though there has been tremendous progress over the decades in the field of materials science and engineering, innovation of new technologies, and need for better performances of existing technologies demands much more from the materials field. More over it is evident that new materials/technologies are needed to be environmental friendly. Some typical needs, thus, of modern materials needs are listed in the following:

- Engine efficiency increases at high temperatures: requires high temperature structural materials

- Use of nuclear energy requires solving problem with residues, or advances in nuclear waste processing.
- Hypersonic flight requires materials that are light, strong and resist high temperatures.
- Optical communications require optical fibers that absorb light negligibly.
- Civil construction – materials for unbreakable windows.
- Structures: materials that are strong like metals and resist corrosion like plastics.

References

1. M. F. Ashby and D. R. H. Jones, Engineering Materials 1, An introduction to Their Properties and Applications, second edition, Butterworth-Heinemann, Woburn, UK, 1996
2. William D. Callister, Jr, Materials Science and Engineering – An introduction, sixth edition, John Wiley & Sons, Inc. 2004.
3. V. Raghavan, Materials Science and Engineering, third edition, Prentice Hall of India Private Limited, New Delhi, 1990.

Chapter 2. Atomic Structure, Interatomic Bonding and Structure of Crystalline Solids

2.1 Atomic Structure and Atomic Bonding in Solids

2.1.1 Atomic Structure

Atoms are composed of electrons, protons, and neutrons. Electrons and protons are negative and positive charged particles respectively. The magnitude of each charged particle in an atom is 1.6×10^{-19} Coulombs.

The mass of the electron is negligible with respect to those of the proton and the neutron, which form the *nucleus* of the atom. The unit of mass is an atomic mass unit (*amu*) = 1.66×10^{-27} kg, and equals 1/12 the mass of a carbon atom. The Carbon nucleus has $Z=6$, and $A=6$, where Z is the number of protons, and A the number of neutrons. Neutrons and protons have very similar masses, roughly equal to 1 *amu* each. A neutral atom has the same number of electrons and protons, Z .

A *mol* is the amount of matter that has a mass in grams equal to the atomic mass in *amu* of the atoms. Thus, a mole of carbon has a mass of 12 *grams*. The number of atoms in a mole is called the Avogadro number, $N_{av} = 6.023 \times 10^{23}$. Note that $N_{av} = 1 \text{ gram}/1 \text{ amu}$.

Calculating n , the number of atoms per cm^3 of a material of density δ (g/cm^3):

$$n = N_{av} \frac{\delta}{M}$$

where M is the atomic mass in *amu* (*grams per mol*). Thus, for graphite (carbon) with a density $\delta = 1.8 \text{ g}/\text{cm}^3$, $M = 12$, we get $6 \times 10^{23} \text{ atoms/mol} \times 1.8 \text{ g}/\text{cm}^3 / 12 \text{ g/mol} = 9 \times 10^{22} \text{ C atoms}/\text{cm}^3$.

For a molecular solid like ice, one uses the molecular mass, $M_{(H_2O)} = 18$. With a density of 1 g/cm^3 , one obtains $n = 3.3 \times 10^{22} \text{ H}_2\text{O molecules/cm}^3$. Note that since the water molecule contains 3 atoms, this is equivalent to $9.9 \times 10^{22} \text{ atoms/cm}^3$.

Most solids have atomic densities around $6 \times 10^{22} \text{ atoms/cm}^3$. The cube root of that number gives the number of atoms per centimeter, about 39 million. The mean distance between atoms is the inverse of that, *or* 0.25 nm. This is an important number that gives the scale of atomic structures in solids.

2.1.2 Atomic bonding in solids

In order to understand the why materials behave like they do and why they differ in properties, it is necessary that one should look at atomic level. The study primarily concentrates on two issues: what made the atoms to cluster together, and how atoms are arranged. As mentioned in earlier chapter, atoms are bound to each other by number of bonds. These inter-atomic bonds are primarily of two kinds: Primary bonds and Secondary bonds. Ionic, Covalent and Metallic bonds are relatively very strong, and grouped as primary bonds, whereas van der Waals and hydrogen bonds are relatively weak, and termed as secondary bonds. Metals and Ceramics are entirely held together by primary bonds - the ionic and covalent bonds in ceramics, and the metallic and covalent bonds in metals. Although much weaker than primary bonds, secondary bonds are still very important. They provide the links between polymer molecules in polyethylene (and other polymers) which make them solids. Without them, water would boil at -80°C , and life as we know it on earth would not exist.

Ionic Bonding: This bond exists between two atoms when one of the atoms is negative (has an extra electron) and another is positive (has lost an electron). Then there is a strong, direct Coulomb attraction. Basically ionic bonds are non-directional in nature. An example is NaCl. In the molecule, there are more electrons around Cl, forming Cl^- and fewer electrons around Na, forming Na^+ . Ionic bonds are the strongest bonds. In real solids, ionic bonding is usually exists along with covalent bonding.

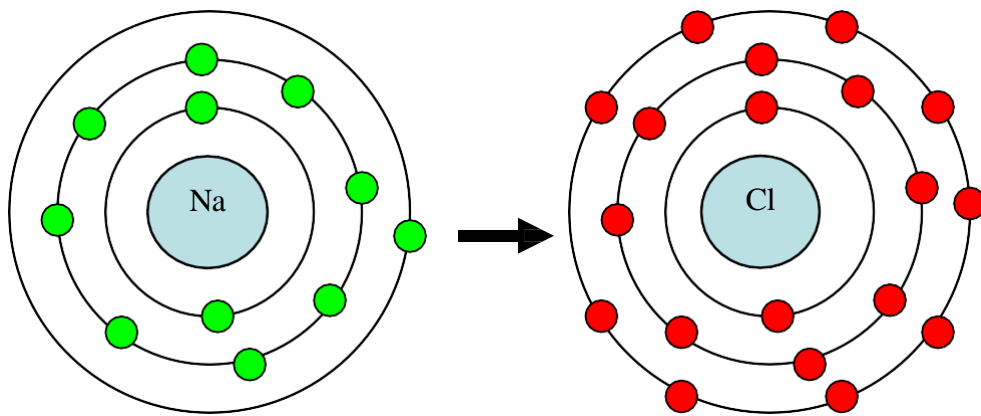

Fig.1 Schematic representation of ionic bonding. Here, Na is giving an electron to Cl to have stable structure

Covalent Bonding: In covalent bonding, electrons are shared between the atoms, to saturate the valency. The simplest example is the H₂ molecule, where the electrons spend more time in between the nuclei of two atoms than outside, thus producing bonding. Covalent bonds are stereo-specific i.e. each bond is between a specific pair of atoms, which share a pair of electrons (of opposite magnetic spins). Typically, covalent bonds are very strong, and directional in nature. The hardness of diamond is a result of the fact that each carbon atom is covalently bonded with four neighboring atoms, and each neighbor is bonded with an equal number of atoms to form a rigid three-dimensional structure.

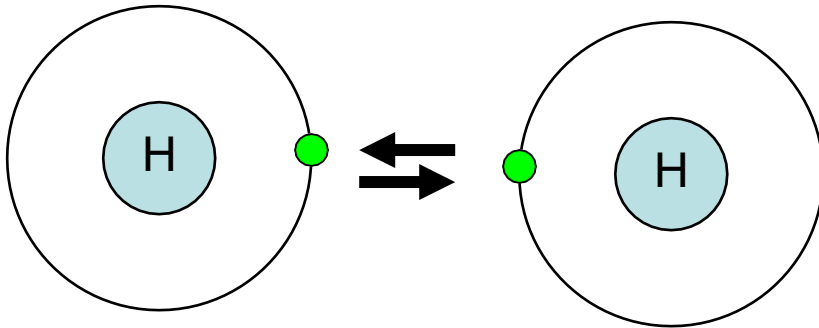

Figure 2. Schematic representation of covalent bond in Hydrogen molecule (sharing of electrons)

Metallic Bonding: Metals are characterized by high thermal and electrical conductivities. Thus, neither covalent nor ionic bondings are realized because both types of bonding localize the valence electrons and preclude conduction. However, strong bonding does occur in metals. The valence electrons of metals also are delocalized. Thus metallic bonding can be viewed as metal containing a periodic structure of positive ions surrounded by a sea of delocalized electrons. The attraction between the two provides the bond, which is non-directional.

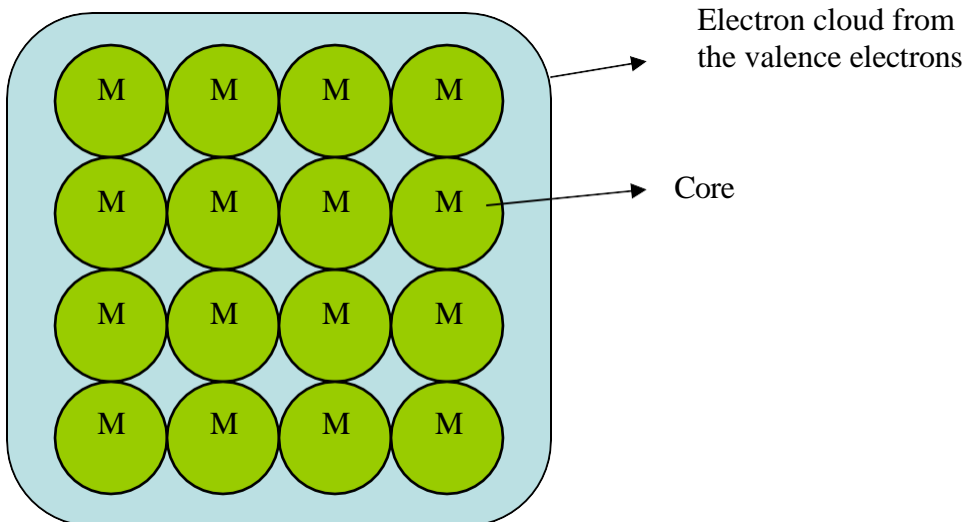

Figure 3. Metallic bonding

Fluctuating Induced Dipole Bonds: Since the electrons may be on one side of the atom or the other, a dipole is formed: the + nucleus at the center, and the electron outside. Since the electron moves, the dipole fluctuates. This fluctuation in atom A produces a fluctuating electric field that is felt by the electrons of an adjacent atom, B. Atom B then polarizes so that its outer electrons are on the side of the atom closest to the + side (or opposite to the – side) of the dipole in A.

Polar Molecule-Induced Dipole Bonds: Another type of secondary bond exists with asymmetric molecules, also called polar molecules because of positively and negatively charged regions. A permanent dipole moment arises from net positive and negative charges that are respectively associated with the hydrogen and chlorine ends of the HCl molecule, leading to bonding. The magnitude of this bond will be greater than for fluctuating induced dipoles.

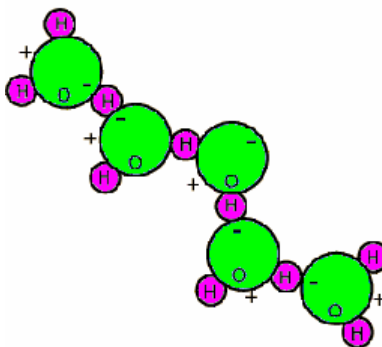

Figure 4. Dipole bond in water

These two kinds of bonds are also called van der Waals bonds. Third type of secondary bond is the hydrogen bond. It is categorized separately because it produces the strongest forces of attraction in this category.

Permanent Dipole Bonds / Hydrogen bonding: It occurs between molecules as covalently bonded hydrogen atoms – for example C-H, O-H, F-H – share single electron with other atom essentially resulting in positively charged proton that is not shielded any electrons. This highly positively charged end of the molecule is capable of strong attractive force with the negative end of an adjacent molecule. The properties of water are influenced significantly by the hydrogen bonds/bridges. The bridges are of sufficient strength, and as a consequence water has the highest melting point of any molecule of its size. Likewise, its heat of vaporization is very high.

2.2 Crystal Structures, Crystalline and Non-Crystalline materials

2.2.1 Crystal structures

All metals, a major fraction of ceramics, and certain polymers acquire crystalline form when solidify, i.e. in solid state atoms self-organize to form *crystals*. Crystals possess a long-range order of atomic arrangement through repeated periodicity at regular intervals in three dimensions of space. When the solid is not crystalline, it is called amorphous. Examples of crystalline solids are metals, diamond and other precious stones, ice, graphite. Examples of amorphous solids are glass, amorphous carbon (a-C), amorphous Si, most plastics.

There is very large number of different crystal structures all having long-range atomic order; these vary from relatively simple structures for metals to exceedingly complex structures for ceramics and some polymers. To discuss crystalline structures it is useful to consider atoms as being hard spheres, with well-defined radii. In this scheme, the shortest distance between two like atoms is one diameter. In this context, use of terms *lattice* and *unit cell* will be handy. *Lattice* is used to represent a three-dimensional periodic array of points coinciding with atom positions. *Unit cell* is smallest repeatable entity that can be used to completely represent a crystal structure. Thus it can be considered that a unit cell is the building block of the crystal structure and defines the crystal structure by virtue of its geometry and the atom positions within.

Important properties of the unit cells are

- The type of atoms and their radii R .
- Cell dimensions (Lattice spacing a , b and c) in terms of R and
- Angle between the axis α , β , γ
- a^* , b^* , c^* - lattice distances in reciprocal lattice , α^* , β^* , γ^* - angle in reciprocal lattice
- n , number of atoms per unit cell. For an atom that is shared with m adjacent unit cells, we only count a fraction of the atom, $1/m$.
- CN , the coordination number, which is the number of closest neighbors to which an atom is bonded.
- APF , the atomic packing factor, which is the fraction of the volume of the cell actually occupied by the hard spheres. $APF = \text{Sum of atomic volumes}/\text{Volume of cell}$.

Some very common crystal structures and relevant properties are listed in table 2.1.

Table 2.1: Common crystal structures and their properties.

Unit Cell	n	CN	a/R	APF
Simple Cubic	1	6	$4/\sqrt{4}$	0.52

Body-Centered Cubic	2	8	$4/\sqrt{3}$	0.68
Face-Centered Cubic	4	12	$4/\sqrt{2}$	0.74
Hexagonal Close Packed	6	12		0.74

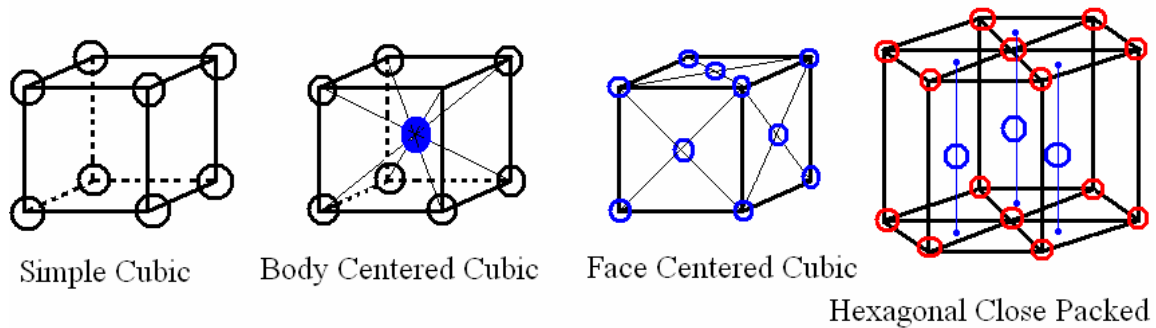

Figure 2.1: Common metallic crystal structures.

2.2.2 Crystalline and Non-crystalline materials

Single Crystals: Crystals can be *single crystals* where the whole solid is one crystal. Then it has a regular geometric structure with flat faces.

Polycrystalline Materials: A solid can be composed of many crystalline grains, not aligned with each other. It is called *polycrystalline*. The grains can be more or less aligned with respect to each other. Where they meet is called a *grain boundary*.

Non-Crystalline Solids: In amorphous solids, there is no long-range order. But amorphous does not mean random, since the distance between atoms cannot be smaller than the size of the hard spheres. Also, in many cases there is some form of short-range order. For instance, the tetragonal order of crystalline SiO_2 (quartz) is still apparent in amorphous SiO_2 (silica glass).

2.3 Miller Indices, Anisotropy, and Elastic behavior of composites

2.3.1 Miller indices:

It is understood that properties of materials depend on their crystal structure, and many of these properties are directional in nature. For example: elastic modulus of BCC iron is greater parallel to the body diagonal than it is to the cube edge. Thus it is necessary to characterize the crystal to identify specific directions and planes. Specific methods are employed to define crystal directions and crystal planes.

Methodology to define crystallographic directions in cubic crystal:

- a vector of convenient length is placed parallel to the required direction.
- the length of the vector projection on each of three axes are measured in unit cell dimensions.
- these three numbers are made to smallest integer values, known as indices, by multiplying or dividing by a common factor.
- the three indices are enclosed in square brackets, $[uvw]$. A family of directions is represented by $\langle uvw \rangle$.

Methodology to define crystallographic planes in cubic crystal:

- determine the intercepts of the plane along the crystallographic axes, *in terms of unit cell dimensions*. If plane is passing through origin, there is a need to construct a plane parallel to original plane.
- take the reciprocals of these intercept numbers.
- clear fractions.
- reduce to set of smallest integers.
- The three indices are enclosed in parenthesis, (hkl) . A family of planes is represented by $\{hkl\}$.

For example, if the x-, y-, and z- intercepts of a plane are 2, 1, and 3. The Miller indices are calculated as:

- take reciprocals: $1/2, 1/1, 1/3$.
- clear fractions (multiply by 6): 3, 6, 2.
- reduce to lowest terms (already there). \Rightarrow Miller indices of the plane are (362).

Figure 2.2 depicts Miller indices for number of directions and planes in a cubic crystal.

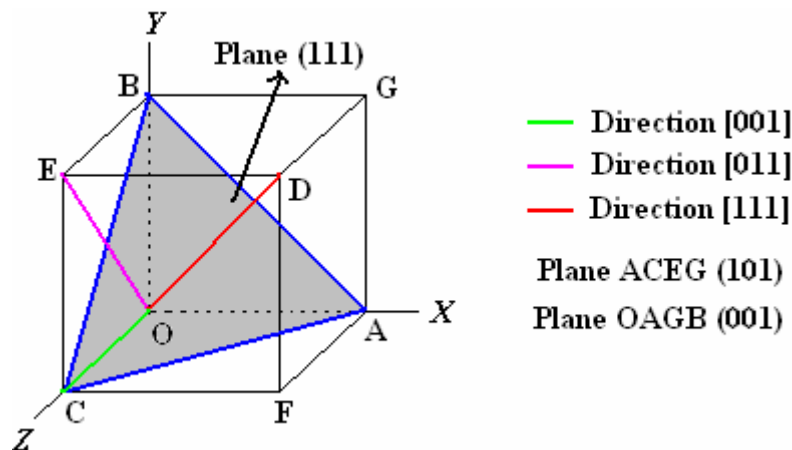

Figure 2.2: Miller indices in a cubic crystal.

Some useful conventions of Miller notation:

- If a plane is parallel to an axis, its intercept is at infinity and its Miller index will be zero.

- If a plane has negative intercept, the negative number is denoted by a bar above the number. *Never alter negative numbers.* For example, do not divide -1, -1, -1 by -1 to get 1,1,1. This implies symmetry that the crystal may not have!
- The crystal directions of a family are not necessarily parallel to each other. Similarly, not all planes of a family are parallel to each other.
- By changing signs of all indices of a direction, we obtain opposite direction. Similarly, by changing all signs of a plane, a plane at same distance in other side of the origin can be obtained.
- Multiplying or dividing a Miller index by constant has no effect on the orientation of the plane.
- The smaller the Miller index, more nearly parallel the plane to that axis, and vice versa.
- When the integers used in the Miller indices contain more than one digit, the indices must be separated by commas. E.g.: (3,10,13)
- By changing the signs of all the indices of (a) a direction, we obtain opposite direction, and (b) a plane, we obtain a plane located at the same distance on the other side of the origin.

More conventions applicable to cubic crystals only:

- $[uvw]$ is normal to (hkl) if $u = h, v = k,$ and $w = l$. E.g.: $(111) \perp [111]$.
- Inter-planar distance between family of planes $\{hkl\}$ is given by:

$$d_{\{hkl\}} = \frac{a}{\sqrt{h^2 + k^2 + l^2}}$$

- $[uvw]$ is parallel to (hkl) if $hu + kv + lw = 0$.
- Two planes $(h_1k_1l_1)$ and $(h_2k_2l_2)$ are normal if $h_1h_2 + k_1k_2 + l_1l_2=0$.
- Two directions $(u_1v_1w_1)$ and $(u_2v_2w_2)$ are normal if $u_1u_2 + v_1v_2 + w_1w_2=0$
- Angle between two planes is given by:

$$\cos\theta = \frac{h_1h_2 + k_1k_2 + l_1l_2}{\sqrt{h_1^2 + k_1^2 + l_1^2} \sqrt{h_2^2 + k_2^2 + l_2^2}}$$

The same equation applies for two directions.

Why Miller indices are calculated in that way?

- Using reciprocals spares us the complication of infinite intercepts.
- Formulas involving Miller indices are very similar to related formulas from analytical geometry.
- Specifying dimensions in unit cell terms means that the same label can be applied to any plane with a similar stacking pattern, regardless of the crystal class of the crystal. Plane (111) always steps the same way regardless of crystal system.

2.3.2 Miller-Bravis indices

Though Miller indices can describe all possible planes through any crystal, Miller-Bravis indices are used in hexagonal crystal systems. This is because they reveal hexagonal symmetry more clearly. Although partially redundant, they are used exclusively for hexagonal systems.

Direction indices are obtained as above where first three indices are representative of projections of the direction over three co-planar axes in the plane called basal plane while the last index denotes the projection over the axis perpendicular to the basal plane. Miller-Bravis indices for a plane are denoted as $[uvtw]$, where $t = -(u+v)$

In the same procedure, planes in a hexagonal crystal are denoted by $(hkil)$, where $i = -(h+k)$.

2.3.3 Anisotropy

It's been agreed that many of the materials properties depend on the crystal structure. However, crystals are not symmetric in all directions, or not the crystal planes same with respect to atomic density/packing. Different directions in the crystal have different packing. For instance, atoms along the edge of FCC crystals are more separated than along its face diagonal. This causes properties to be different in different directions. This directionality of properties is termed as *Anisotropy*.

Substances in which measured properties are independent of direction in which they are measured are called *isotropic*. Though, in polycrystalline materials, the crystallographic orientations of individual grains are random, specimen may behave isotropically.

2.3.4 Elastic Behavior of Composites

The idea is that by combining two or more distinct materials one can engineer a new material with the desired combination of properties (e.g., light, strong, corrosion resistant). The idea that a better combination of properties can be achieved is called the *principle of combined action*.

For example, Pearlitic steel that combines hard and brittle Cementite with soft and ductile ferrite to get a superior material.

A composite is defined as a artificially made multi-phase material, where constituent phases are chemically dissimilar and separated by a distinct interface. Thus, composites shall have at least two or more constituent phases. Many of the composites are made of two phases – one is termed as *matrix*, which is continuous and surrounds the other phase, called *dispersed phase*. Dispersed phase can exist in many forms like particulates, short-/long- fibers.

Properties of composites depend on

- Properties of the constituent phases.
- Geometry of dispersed phase (particle size, size distribution, orientation).
- Amount of each constituent phase.

Classification of composites based on geometry of dispersed phase:

- Particle-reinforced (large-particle and dispersion-strengthened)
- Fiber-reinforced (continuous (aligned) and short fibers (aligned or random))
- Structural (laminates and sandwich panels)

Classification of composites based on matrix phase:

- Metal Matrix Composites.
- Polymer Matrix Composites.
- Ceramic Matrix Composites.

Composite properties can be calculated using *rule of mixtures*. For example, elastic modulus of a particle reinforced composite bound by the limits given by

$$E_c(u) = E_m V_m + E_p V_p$$

$$E_c(l) = \frac{E_m E_p}{E_m V_p + E_p V_m}$$

where E and V denote the elastic modulus and volume fraction respectively; c , m , and p represent composite, matrix, and particulate phases.

However, in case of continuous fiber reinforced composites upper bound is applicable to condition of longitudinal loading, while the lower bound is applicable to transverse loading condition. The above equations can be simplified using the following relations:

$$V_m + V_p = 1$$

When fiber orientation is random, or short and discontinuous fibers are used, rule of mixtures will be modified as follows to take care of the randomness of fibers:

$$E_{cd} = E_m V_m + K E_f V_f$$

where K – is fiber efficiency parameter that depends on V_f and E_f/E_m ratio. K 's values are less than unity, usually attains a value in the range of 0.1 to 0.6.

Many applications, like in aircraft parts, there is a need for high strength per unit weight (specific strength). This can be achieved by composites consisting of a low-density (and soft) matrix reinforced with stiff fibers.

2.4 Structure and properties of polymers

Polymers are common in nature, in the form of wood, rubber, cotton, leather, wool, silk, proteins, enzymes, starches, cellulose. Artificial polymers are made mostly from oil. Their use has grown exponentially, especially after WW2 (World War-2). The key factor is the very low production cost and useful properties (e.g., combination of transparency and flexibility, long elongation, etc.).

Most polymers are organic, and formed from hydrocarbon molecules. These molecules can have single, double, or triple carbon bonds. A *saturated hydrocarbon* is one where all bonds are single, i.e. the number of atoms is maximum (or saturated). Among this type are the paraffin compounds, C_nH_{2n+2} . In contrast, non-saturated hydrocarbons contain some double and triple bonds.

Isomers are molecules that contain the same molecules but in a different arrangement. An example is butane and iso-butane. Some physical properties of hydrocarbons depend on the isomeric state.

2.4.1 Polymer molecules

Polymer molecules are huge, macromolecules that have internal covalent bonds. For most polymers, these molecules form very long chains. The backbone is a string of carbon atoms, often single bonded. Polymers are composed of basic structures called *mer* units. A molecule with just one mer is a monomer. Within each molecule / mer atoms are bonding together by strong covalent bonds. When many mers are together, they form polymer. Bi-functional monomers may bond with two other units in forming 2-D chain- like structures; while Tri-functional monomers can form three active bonds, and thus 3-D molecular network. Examples of polymers are polyvinyl chloride (PVC), poly-tetra- fluoro-ethylene (PTFE or Teflon), polypropylene, nylon and polystyrene. When all the mers are the same, the molecule is called a *homopolymer*. When there is more than one type of mer present, the molecule is a *copolymer*.

The mass of a polymer is not fixed, but is distributed around a mean value, since not all polymer chains will grow same extent. The average molecular weight can be obtained by averaging the masses with the fraction of times they appear (*number-average*) or with the weight fraction of the molecules (*weight-average*). Another representation of average chain size is *degree of polymerization* (n) – average number of mer units in a chain. It is obtained by dividing the average mass of the polymer by the mass of a mer unit. Numbers of polymer characteristics are affected by the magnitude of the molecular weight. Short chain polymers usually exist in form of gases or liquids at room temperature; where as medium range polymers are waxy solids and soft resins. Solid polymers are commonly having weights ranging between 10K and several million g/mol.

2.4.2 Polymer structures

Polymers consist of large number of molecular chains which are usually not linear; bending and rotations can occur around single C-C bonds (double and triple bonds are very rigid). Random kinks and coils in chains along with bending of chains lead to

intertwining and entanglement of neighboring chains, situation like in the spaghetti structure. These characteristic entanglements are responsible for a number of properties specific to polymers, e.g.: large elastic extension. However, physical properties of polymers depend not only on molecular weight and shape, but also on differences in structure of the chains. It should be remembered that polymers are not usually of only one distinctive structural type, though they are classified into different groups. Typical polymer chain structures are: (a) *linear*, where mer units are joined together end to end in single chains. E.g.: PVC, nylon. (b) *branched*, where side-branch chains are connected to main ones. Branching of polymers lowers polymer density because of lower packing efficiency. (c) *cross-linked*, where chains are joined one to another at various positions by covalent bonds. This cross-linking is usually achieved at elevated temperatures by additive atoms. E.g.: vulcanization of rubber. (d) *network*, trifunctional mer units with 3- D networks comes under this category. E.g.: epoxies, phenol-formaldehyde.

2.4.3 Polymer crystallinity

Crystallinity in polymers is more complex than in metals. Polymer molecules are often partially crystalline (*semicrystalline*), with crystalline regions dispersed within amorphous material. The degree of crystallinity may range from completely amorphous to almost entirely crystalline; on the other hand metals are almost always crystalline whereas ceramics are either completely crystalline or noncrystalline. The degree of crystallinity of a polymer depends on cooling path, and also on chain configuration. For copolymers, the more irregular and random the mer arrangement, the greater is probability for noncrystalline nature. Crystalline polymers are denser than amorphous polymers, so the degree of crystallinity can be obtained from the measurement of density.

Different models have been proposed to describe the arrangement of molecules in semicrystalline polymers. In the fringed-micelle model, the crystallites (micelles) are embedded in an amorphous matrix. Polymer single crystals grown are shaped in regular platelets (lamellae). Spherulites are chain-folded crystallites in an amorphous matrix that grow radially in spherical shape “grains”. These are considered to be the polymer analogue of grains in polycrystalline metals and ceramics. Many semicrystalline polymers form spherulites; each spherulite consists of a collection of ribbonlike chain- folded lamellar crystallites that radiate outward from its center. E.g.: polyethelene, PVC.

A polymer’s response to mechanical forces under elevated temperatures is related to its molecular structure. Based on this response, polymers are classified as: *thermoplasts* (soften when heated and harden when cooled), and *thermosets* (become permanently hard when heat is applied and do not soften upon subsequent heating). Thermosets are generally harder and stronger than thermoplasts, and have better dimensional stability. Most of the cross-linked and network polymers are thermosets; whereas linear and some branched polymers are thermoplasts.

2.4.4 Properties of polymers

Fluids and amorphous solids undergo viscous flow when external forces are applied. It is well known that polymers exhibit very high viscosity in order of 10^{12} Pa.s at room temperature. Polymers are non-Newtonian in nature, and formed into plastic products at a temperature above their glass-transition temperature. It is evident that temperature has very strong influence on mechanical behavior of polymers. Elastic strain occurs simultaneously with viscous flow, resulting in visco-elastic deformation of polymers under externally applied loads. Below the glass transition temperature elastic deformation dominates and the material behaves rigid. In the range of glass temperature, the materials is leathery; in the rubber plateau, polymers deform readily but quickly regain their previous shape if the stress is removed. At still higher temperatures, under sustained loads, the polymer deforms extensively by viscous flow. Figure below depicts temperature effect on deformation behavior of polymers.

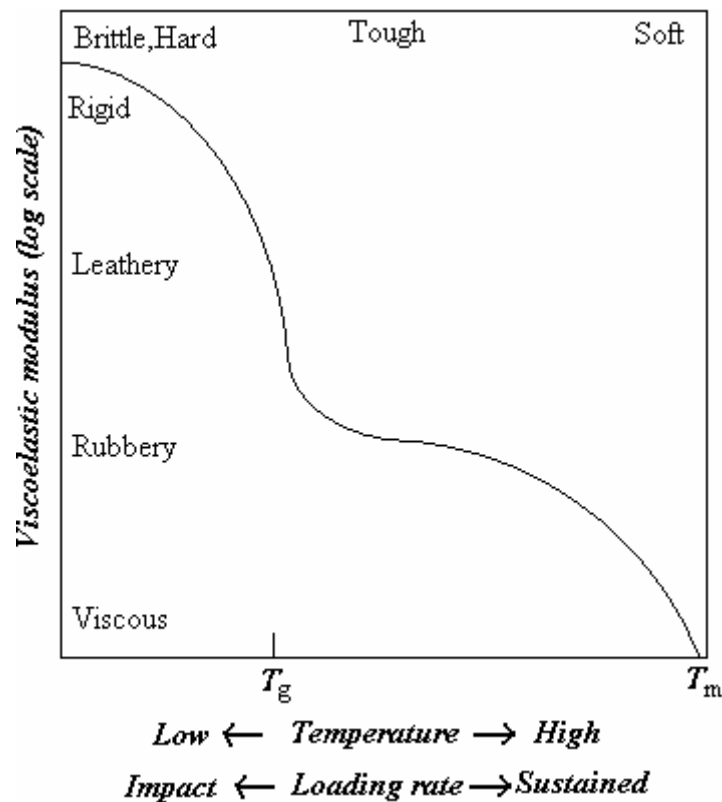

Figure 2.3: Dependence of polymer viscosity on temperature and/or loading rate.

2.5 Structure and properties of ceramics

Ceramics are inorganic and non-metallic materials that are commonly electrical and thermal insulators, brittle and composed of more than one element (e.g., two in Al_2O_3). As ceramics are composed of two or more elements, their crystal structures are generally more complex than those of metals. Ceramic bonds are mixed, ionic and covalent, with a proportion that depends on the particular ceramics. The ionic character is given by the difference of electronegativity between the cations (+) and anions (-). Covalent bonds involve sharing of valence electrons. Very ionic crystals usually involve cations which

are alkalis or alkaline-earths (first two columns of the periodic table) and oxygen or halogens as anions.

The building criteria for the ceramic crystal structure are as follows:

- maintain neutrality (charge balance dictates chemical formula)
- achieve closest packing

The crystal stability condition i.e. condition of minimum energy implies maximum attraction and minimum repulsion. This leads to contact and configurations such that anions have the highest number of cation neighbors (coordination number) and vice versa. The coordination number is dependent on cation-anion radius ratio, which can be determined from geometric relations. Table 2.2 presents relevant coordination numbers and radius ratios.

Table 2.2. Co-ordination number dependency on cation-anion radius ratio.

Cation-anion radius ratio (r_c/r_a)	< 0.155	0.155 – 0.225	0.225 – 0.414	0.414 – 0.732	0.732 – 1.000	> 1.000
Coordination number	2	3	4	6	8	12

Figure-2.4 presents schematic arrangement of cations and anions with respective coordinate positions for different radius ratios.

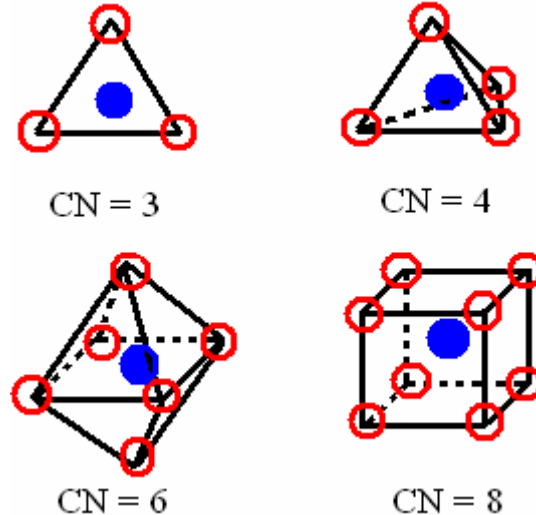

Figure 2.4: Ion arrangements for different coordination numbers.

2.5.1 Ceramic crystal structures

AX-type ceramic crystal structures: Most common ceramics are made of equal number of cations and anions, and are referred to as AX compounds (A-cation, and X-anion). These ceramics assume many different structures, named after a common material that possesses the particular structure.

Rock salt structure: here the coordination number is 6, i.e. $r_c/r_a = 0.414-0.732$. This structure can be viewed as an FCC of anions with cations occupying center of each edge and the center of the cell. Thus it can be said that lattice is made of two interpenetrating FCC lattices, one composed of cations, and the other of anions. E.g.: NaCl, MgO, FeO.

Cesium Chloride structure: here the coordination number is 8. Crystal structure consists of anions at corners of a cube while a cation occupies the center, and vice versa. E.g.: CsCl.

Zinc Blende structure: here the coordination number is 4. Unit cell is composed of one kind of ions occupying corners and face centers of a cube, while the other kind of ions occupies the interior tetrahedral positions. E.g.: ZnS, SiC.

A_mX_p -type structures: when the charges of cation and anions are not the same, to maintain the neutrality, ceramic structures with chemical formula would exist. For example – CaF_2 with $r_c/r_a = 0.8$, and thus coordination number of 8. It can be expected that crystal structure could be the same as that of CsCl. However cations are half many as anions, thus only half the center positions are occupied. One unit cell shall be made of eight cubes. E.g.: UO_2 , ThO_2 , PuO_2 .

$A_mB_nX_p$ -type structures: it is possible that ceramics do have more than one kind of cations. E.g.: $BaTiO_3$. unit cell is made of cube where Ba^{2+} ions occupies all eight corners, T^{4+} occupies cube center, while O^{2-} are at center of each face. This structure is called *perovskite crystal structure*.

It is worth to understand and know more about some common most common ceramic in nature. For example: silicates and carbon.

2.5.2 Silicates

Oxygen and Silicon are the most abundant elements in Earth's crust. Their combination (silicates) occurs in rocks, soils, clays and sand. The bond is weakly ionic, with Si^{4+} as the cation and O^{2-} as the anion. However the bonds in silicates are strongly of covalent character with strong directional Si-O bonds. Basic unit of silicates structures are thus is SiO_4^{4-} tetrahedron that consists of four oxygen atoms at corners of tetrahedron, and silicon atom at the center of it. Various silicate structures consists SiO_4^{4-} unit bonded in 1-, 2-, and 3- dimensions.

In silica (SiO_2) every oxygen atom is shared by adjacent tetrahedra. Silica can either be crystalline (e.g., quartz) or amorphous, as in glass. Crystalline forms of silica are known to be complicated and comparatively open, thus of low densities compared with amorphous glasses. Soda glasses melt at lower temperature than amorphous SiO_2 because the addition of Na_2O (soda) that act as *network modifier* breaks the tetrahedral network. Addition of *intermediates* such as Al_2O_3 , TiO_2 substitute of silicon atoms and become part of stabilized network. Addition of network modifiers and intermediates lowers melting point, and thus it is easy to form glass, for instance, bottles.

In complicated silicate structure, corner oxygen atom of basic unit is shared by other tetrahedra, resulting in formulas such as SiO_4^{4-} , $\text{Si}_2\text{O}_7^{6-}$, $\text{Si}_3\text{O}_9^{6-}$, etc. The repeating unit of 2-D sheet or layered structure is represented as $\text{Si}_2\text{O}_5^{2-}$. Such layered structures are characteristics of clays and other minerals.

2.5.3 Carbon

Carbon is not really a ceramic, but one of its allotropic form, diamond may be considered as a ceramic. *Diamond* has very interesting and even unusual properties such as:

- possesses diamond-cubic structure (like Si, Ge)
- consists covalent C-C bonds
- having highest hardness of any material known
- very high thermal conductivity (unlike ceramics)
- transparent in the visible and infrared, with high index of refraction
- semiconductor (can be doped to make electronic devices)
- meta-stable (transforms to carbon when heated)

Synthetic diamonds are made by application of high temperatures and pressures or by chemical vapor deposition. Future applications of this latter, cheaper production method include hard coatings for metal tools, ultra-low friction coatings for space applications, and microelectronics.

Graphite, another allotropic form of carbon, has a layered structure with very strong hexagonal bonding within the planar layers (using 3 of the 3 bonding electrons) and weak, van der Waals bonding between layers using the fourth electron. This leads to easy inter-planar cleavage and applications as a lubricant and for writing (pencils). Graphite is a good electrical conductor and chemically stable even at high temperatures. Applications include furnaces, rocket nozzles, electrodes in batteries, etc.

Recently (1985) discovered allotropic form of carbon is the C_{60} molecule, also known as *fullerene* or *bucky-ball* (after the architect Buckminster Fuller who designed the geodesic structure that C_{60} resembles.). Structure of this form resembles a hallow spherical cluster of 60 atoms, and is found to consist of 20 hexagons and 12 pentagons where no two pentagons share a common edge. Fullerenes and related structures like nanotubes are exceptionally stiff, strong, and ductile. Future applications of fullerenes are as a structural material and possibly in microelectronics, due to the unusual properties that result when fullerenes are doped with other atoms.

2.5.4 Imperfections in ceramics

Imperfections in ceramics include point defects and impurities. Their formation is strongly affected by the condition of charge neutrality (creation of unbalanced charges requires the expenditure of a large amount of energy). Both vacancies and interstitials are possible in ceramics as in metals; however as ceramics have more than one element these defects can be associated with each of these elements. Neutral charge defects include the Frenkel and Schottky defects. A *Frenkel-defect* is a vacancy- interstitial pair of cations

(placing large anions in an interstitial position requires a lot of energy in lattice distortion). A *Schottky-defect* is a pair of nearby cation and anion vacancies.

Non-stoichiometry refers to a change in composition so that the elements in the ceramic are not in the proportion appropriate for the compound (condition known as stoichiometry). To minimize energy, the effect of non-stoichiometry is a redistribution of the atomic charges. Introduction of impurity atoms in the lattice is likely in conditions where the charge is maintained. This is the case of electronegative impurities that substitute lattice anions or electropositive substitutional impurities. This is more likely for similar ionic radii since this minimizes the energy required for lattice distortion. Defects will appear if the charge of the impurities is not balanced.

2.5.5 Mechanical response of ceramics

Brittle Fracture of Ceramics: The brittle fracture of ceramics limits their engineering applications. It occurs due to the unavoidable presence of microscopic flaws (micro-cracks, internal pores, and atmospheric contaminants) that result during cooling from the melt. The flaws need to crack initiation, and crack propagation (perpendicular to the applied stress) is usually trans-granular, along cleavage planes. The flaws cannot be closely controlled in manufacturing; this leads to a large scatter in the fracture strength of ceramic materials.

Under compressive stresses, however, flaws do not associate with amplification of stress. Hence, the compressive strength of ceramics is typically ten times to their tensile strength. This makes ceramics good structural materials under compression (e.g., bricks in houses, stone blocks in the pyramids), but not in conditions of tensile stress, such as under flexure.

Plastic deformation in crystalline ceramics is by slip, which is difficult due to the structure and the strong local (electrostatic) potentials. There is very little plastic deformation before fracture. Non-crystalline ceramics, like common glass, deform by viscous flow (like very high-density liquids) as deformation can not occur by slip because of absence of regular atomic structure, which occurs in metals. Characteristic property of viscous flow, viscosity, is a measure of non-crystalline material's resistance to deformation. It was found to decrease with increasing temperature. At room temperature, the viscosity of many non-crystalline ceramics is extremely high.

References

1. William D. Callister, Jr, Materials Science and Engineering – An introduction, sixth edition, John Wiley & Sons, Inc. 2004.
2. B. D. Cullity and S. R. Stock, Elements of X-Ray Diffraction, Third Edition, Prentice Hall, Upper Saddle River, NJ, 2001
3. Lawrence H. Van Vlack, Elements of Materials Science and Engineering, sixth edition, Addison Wesley Longman, Inc. New York, 1998

Crystal Structure

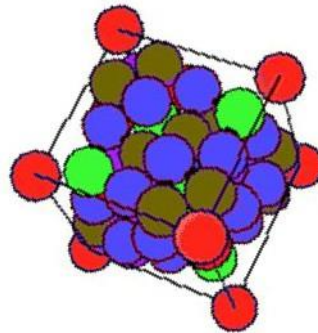

Preface

Crystal structure is one of the most important aspects of materials science and engineering as many properties of materials depend on their crystal structures. The basic principles of many materials characterization techniques such as X-ray diffraction (XRD), Transmission electron microscopy (TEM) are based on crystallography. Therefore, understanding the basics of crystal structures is of paramount importance.

Atomic arrangement

Crystalline SiO₂
(Quartz)

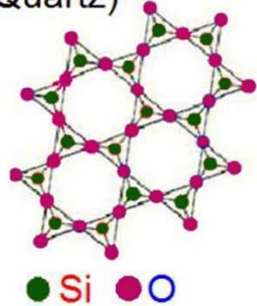

Solid

Crystalline

Amorphous

Amorphous SiO₂
(Glass)

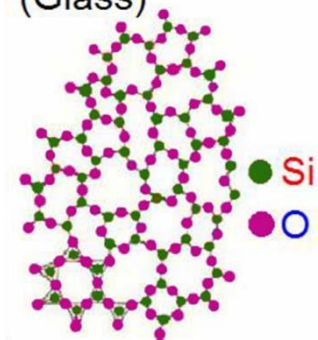

Crystalline – periodic arrangement of atoms: definite repetitive pattern

Non-crystalline or **Amorphous** – random arrangement of atoms.

The periodicity of atoms in crystalline solids can be described by a network of points in space called lattice.

Space lattice

- A space lattice can be defined as a three dimensional array of points, each of which has identical surroundings.
- If the periodicity along a line is a , then position of any point along the line can be obtained by a simple translation, $r_u = ua$.
- Similarly $r_{uv} = ua + vb$ will repeat the point along a 2D plane, where u and v are integers.

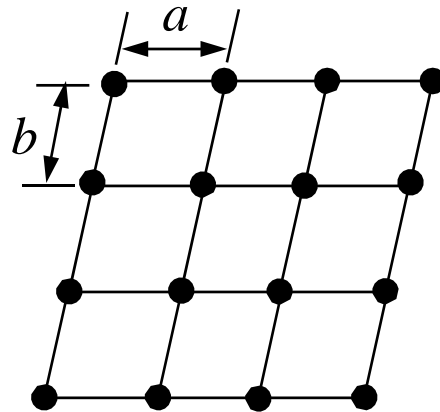

Symmetry

Symmetry

- Symmetry refers to certain pattern or arrangement. A body is symmetrical when it is reproduced by certain operation.

Symmetry

- The symmetry word (somewhat distorted) itself shows 2-fold rotation symmetry (restored by 180° rotation)
- In the picture below the plane looks identical after a 90° rotation. The plane has 4 fold rotation symmetry as it repeats itself 4 times (shown by the red dot) in a full 360° rotation.

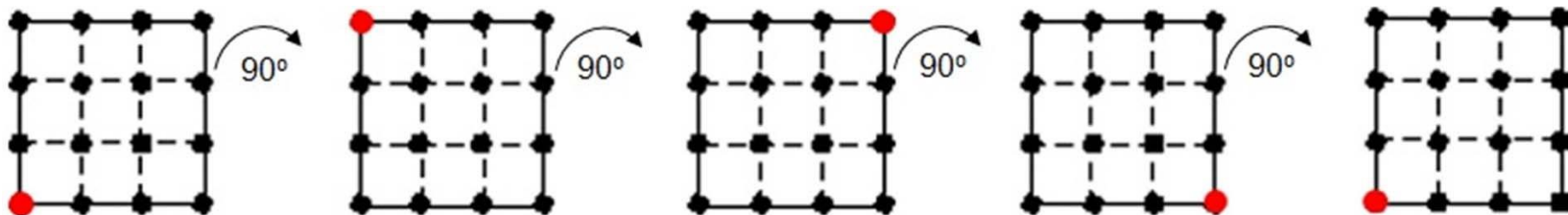

Symmetry operations

1. Translation
2. Rotation
3. Reflection
4. Inversion

Translation

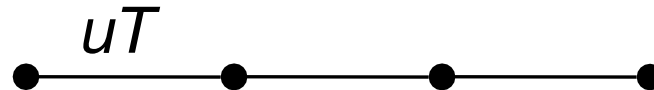

The first point is repeated at equal distances along a line by a translation uT , where T is the translation vector and u is an integer.

Translation on a point with coordinates $xyz \rightarrow x+a \ y+b \ z+c$ where, a , b and c are the unit vectors in x , y and z directions respectively.

Symmetry operations

Rotation

A rotation can be applied on the translation vector T in all directions, clock or anti-clock wise, through equal angles α in the 2D space.

If two rotation operations, one each in clock and anti-clock direction, are applied on the translation vector T , it will create two more lattice points. Because of the regular pattern, the translation between these two points will be some multiple of T (pT).

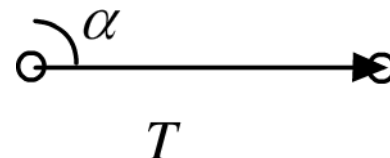
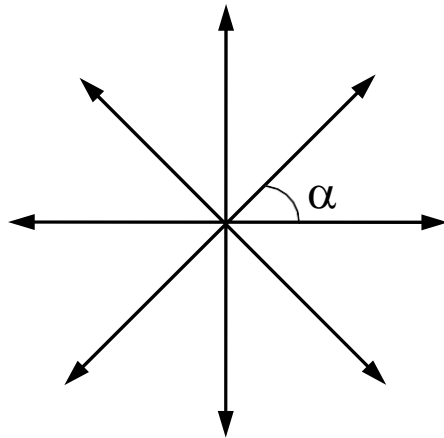

Symmetry operations

Rotation

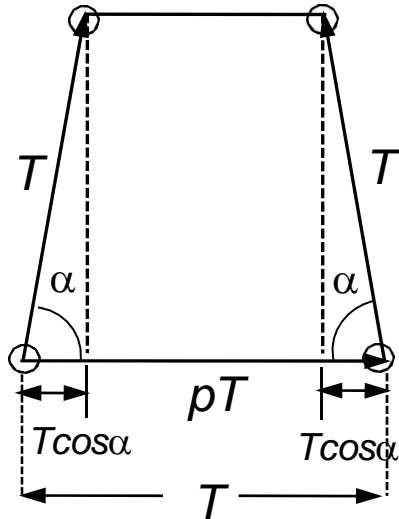

$$T = T \cos \alpha + pT + T \cos \alpha = pT + 2T \cos \alpha$$

$$\cos \alpha = (1 - p)/2$$

p	α°	n-fold	Symbol
0	60	6	⬡
1	90	4	■
2	120	3	▲
3	180	2	●
-1	0/360	1	

An n-fold rotation symmetry means rotation through an angle of $2\pi/n$ will repeat the object or motif n times in a full 360° rotation. $n = 1$ means no symmetry.

Rotation

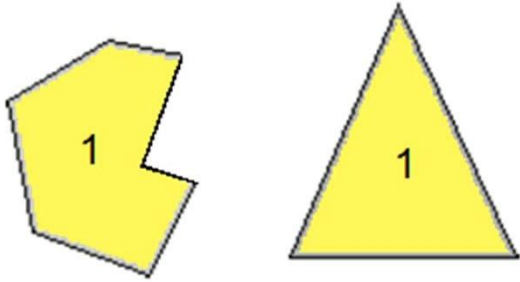

1-Fold Rotation Axis - An object that requires rotation of a full 360° to repeat itself has no rotational symmetry.

2-fold Rotation Axis - If an object appears identical after a rotation of 180° , that is twice in a 360° rotation, then it is said to have a 2-fold ($2\pi/180$) rotation symmetry

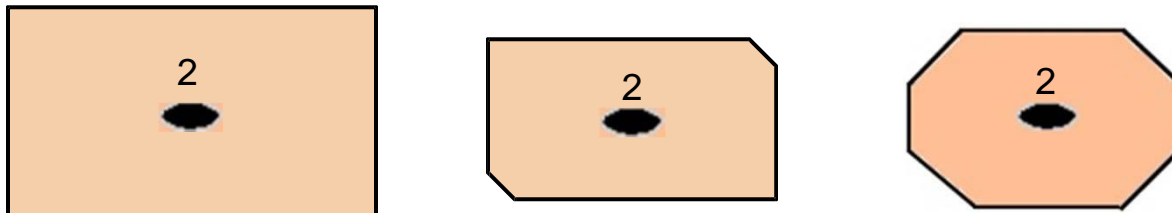

Rotation

Similarly we have 3, 4 and 6-fold rotational symmetry

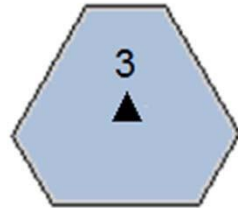
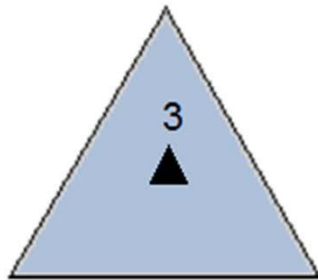

3 fold – $2\pi/120$

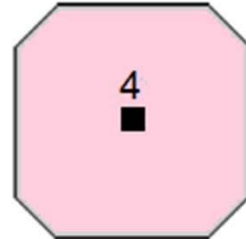
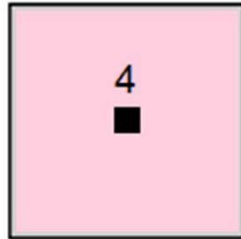

4 fold – $2\pi/90$

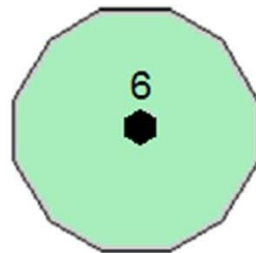
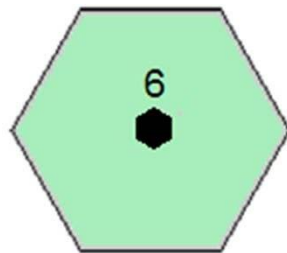

6 fold – $2\pi/60$

Rotation

Is it possible to have 5, 7 or 8-fold rotation symmetry?

Objects with 5, 7 and 8 or higher order symmetry do exist in nature, e.g. star fish (5-fold), flowers with 5 or 8-fold symmetry.



However, these are not possible in crystallography as they cannot fill the space completely

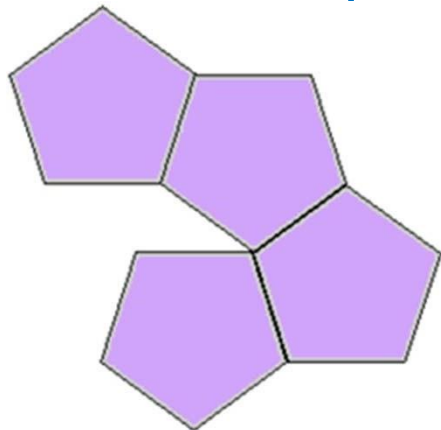

5 fold

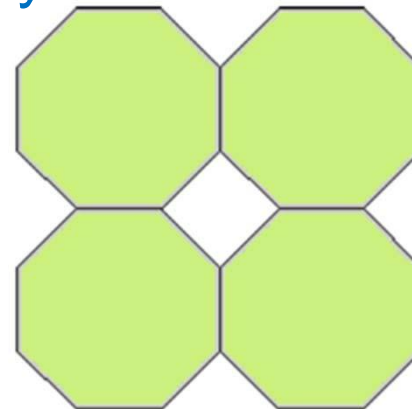

8 fold

Reflection or Mirror symmetry

An object with a reflection symmetry will be a mirror image of itself across a plane called mirror plane (m).

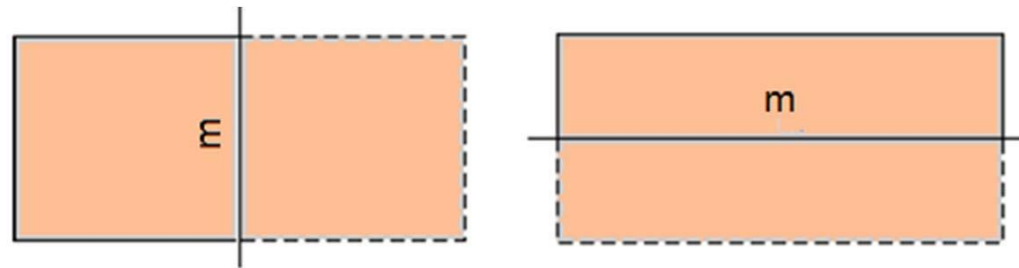

AMAN A PLAN A CANAL PANAMA

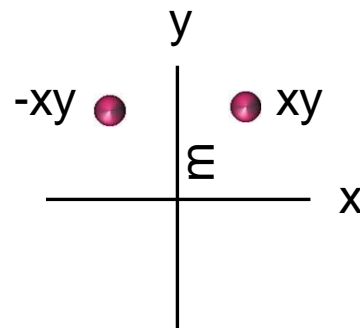

Reflection operation: $xyz \rightarrow -x y z$ ($\bar{x} y z$) across a mirror plane perpendicular to x axis

Symmetry and Space lattice

Symmetry elements discussed so far define five types of 2D space lattices. When a translation is applied to the third direction these lattices create a total of 7 crystal systems.

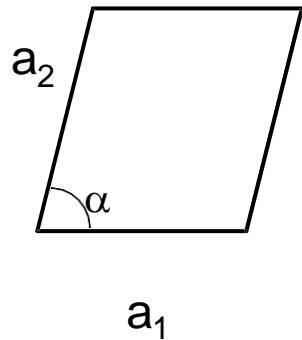

2-fold
Parallelogram

$a_1 \neq a_2, \alpha = \text{Any}$

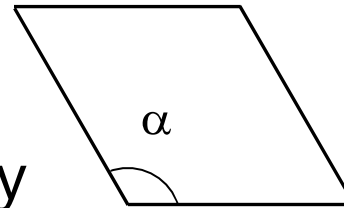

3, 6-fold
Hexagonal

$a_1 = a_2, \alpha = 120^\circ$

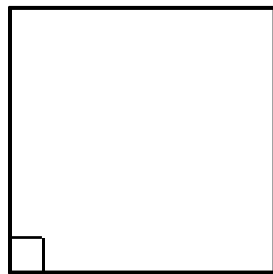

4-fold: Square
 $a_1 = a_2, \alpha = 90^\circ$

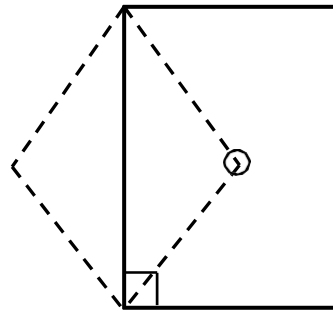

Centered-Rectangular
 $a_1 \neq a_2, \alpha = 90^\circ$

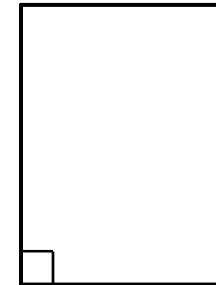

Primitive-Rectangular
 $a_1 \neq a_2, \alpha = 90^\circ$

Inversion – Center of symmetry

In this operation, every part of the object is reflected through an inversion center called center of symmetry which is denoted as i . The object is reproduced inverted from its original position.

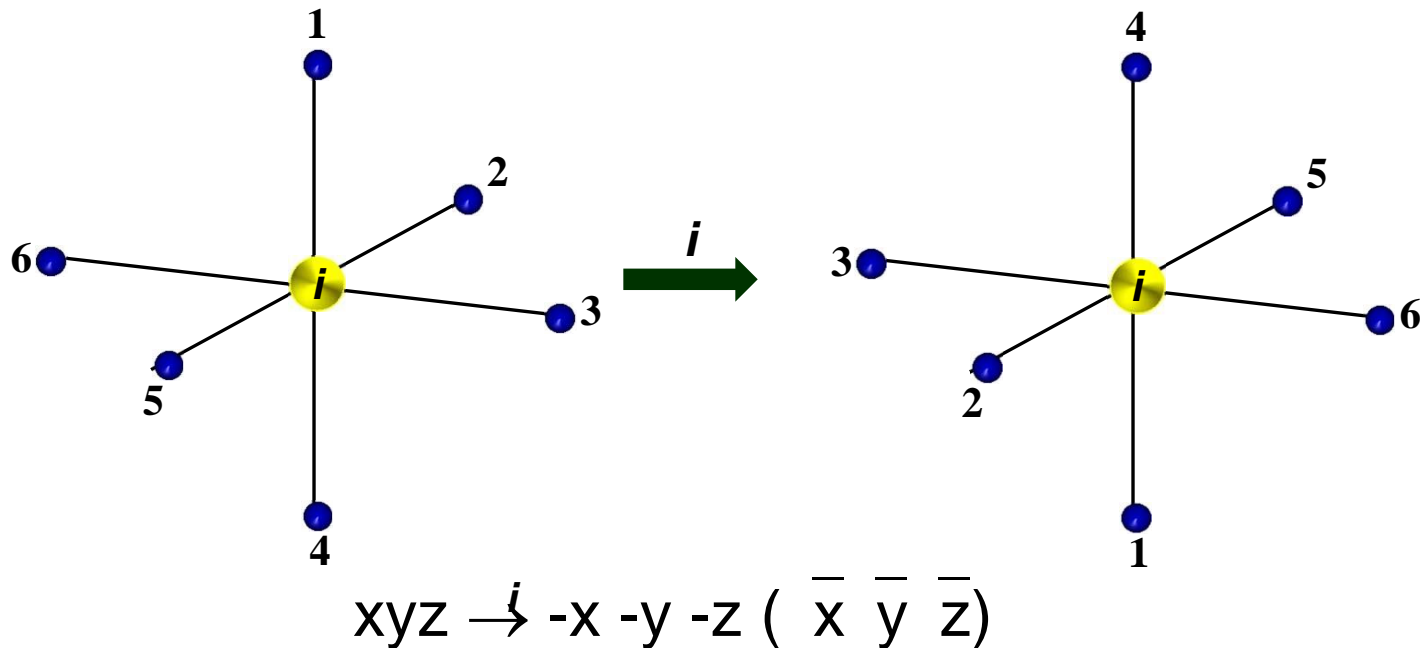

Combined operations

Combined symmetry operations also exist. For example, rotation can be combined with inversion which is called **roto-inversion**. The roto-inversion axis is denoted as \bar{n} . For example, a 6-fold roto-inversion ($\bar{6}$) involves rotating the object by 60° ($360/6$), and inverting through a symmetry center.

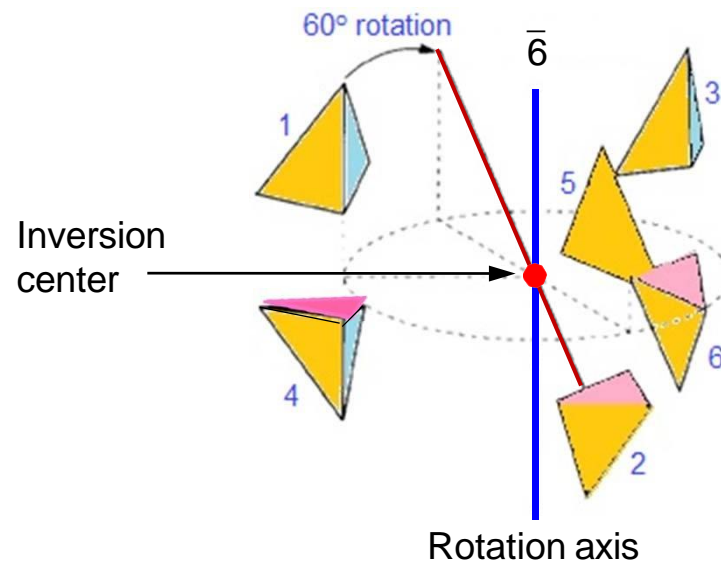

Point and Space groups

Symmetry operations generate a variety of arrangements of lattice points in three dimensions. There are **32** unique ways in which lattice points can be arranged in space. These non-translation elements are called ***point-groups***.

A large number of 3D structures are generated when translations [linear translation, translation + reflection (glide plane) and translation + rotation (screw axis)] are applied to the point groups. There are **230** unique shapes which can be generated this way. These are called ***space groups***.

Hermann-Mauguin Symbols

- The 32 point groups are denoted by notations called Hermann-Mauguin symbols. These symbols basically describe the unique symmetry elements present in a body.
- The shape in Fig.(a) contains 1 4-fold axis, 4 2-fold axes, 5 mirror planes. 3 mirror planes and 2 2-fold axes are unique as others can be produced by a symmetry operation. Therefore, point group symbol for this shape is $4/m2/m2/m$. The “/” between 4 or 2 and m indicates that they are perpendicular to each other.

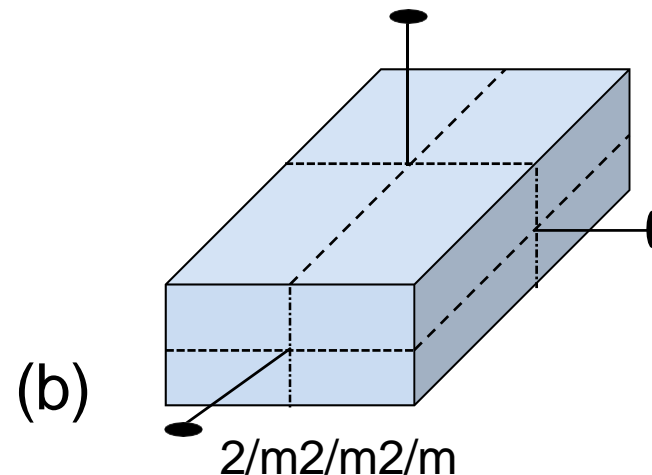
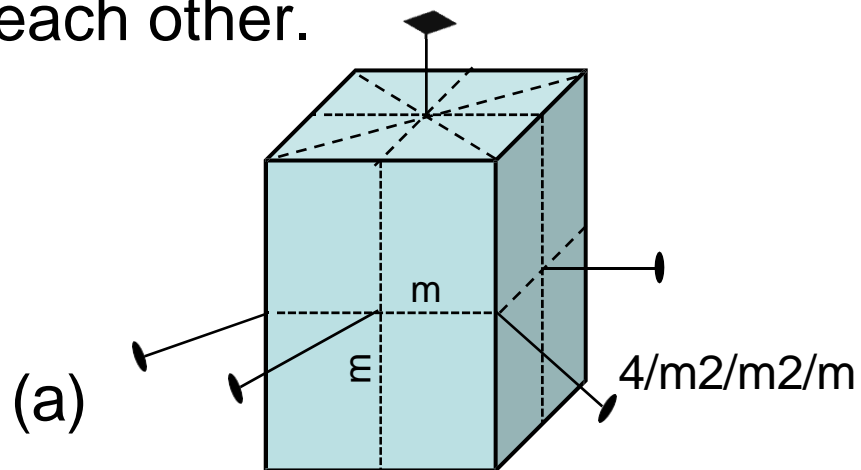

Summary

- ❑ Space lattice is arrangement of points with each point having exactly same surroundings.
- ❑ Symmetry operations restore a body to its original position.
- ❑ There are four symmetry operations – Translation, reflection, rotation and inversion.
- ❑ There are 32 point groups and 230 space groups.
- ❑ Hermann-Mauguin symbols are used to denote point groups.

References

<http://www.tulane.edu/~sanelson/eens211/index.html#Lecture Notes>

<http://www.tulane.edu/~sanelson/eens211/introsymmetry.pdf>

<http://www.tulane.edu/~sanelson/eens211/32crystalclass.pdf>

Crystal Systems

- The space lattice points in a crystal are occupied by atoms.
- The position of any atom in the 3D lattice can be described by a vector $r_{uvw} = ua + vb + wc$, where u , v and w are integers.

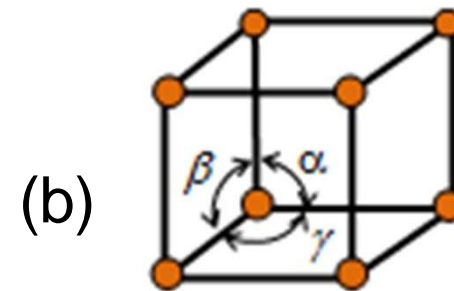
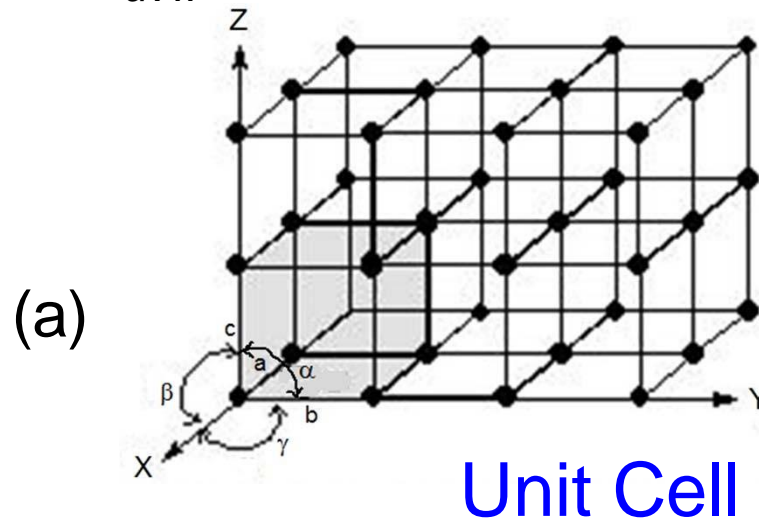

The three unit vectors, a , b , c can define a cell as shown by the shaded region in Fig.(a) This cell is known as unit cell (Fig. b) which when repeated in the three dimensions generates the crystal structure.

Crystal Systems

Bravais Lattice

The unit vectors a , b and c are called lattice parameters. Based on their length equality or inequality and their orientation (the angles between them, α , β and γ) a total of 7 crystal systems can be defined. With the centering (face, base and body centering) added to these, 14 kinds of 3D lattices, known as ***Bravais lattices***, can be generated.

Crystal Systems

Cubic: $a = b = c$, $\alpha = \beta = \gamma = 90^\circ$

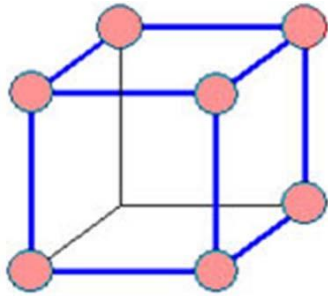

Simple
cubic

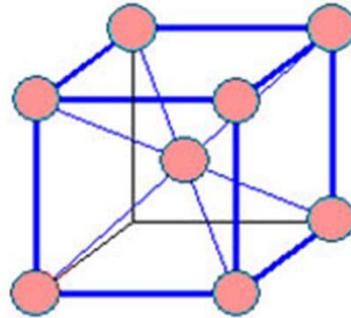

Body-centered
cubic (BCC)

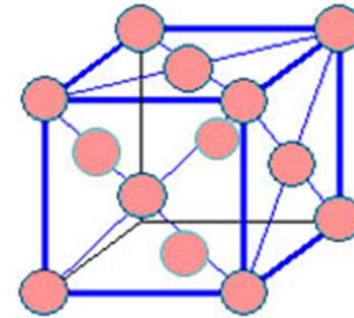

Face-centered
cubic (FCC)

Tetragonal: $a = b \neq c$, $\alpha = \beta = \gamma = 90^\circ$

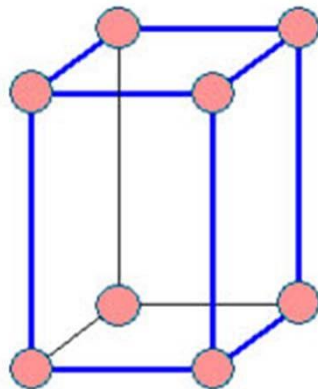

Simple
Tetragonal

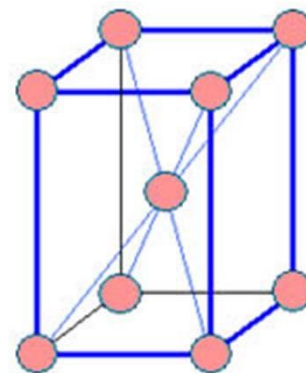

Body-centered
Tetragonal (BCT)

Crystal Systems

Orthorhombic: $a \neq b \neq c$, $\alpha = \beta = \gamma = 90^\circ$

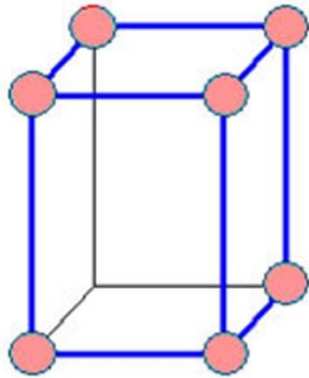

Simple

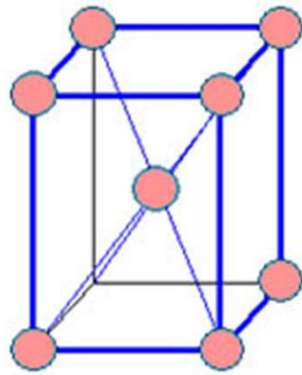

Body-centered

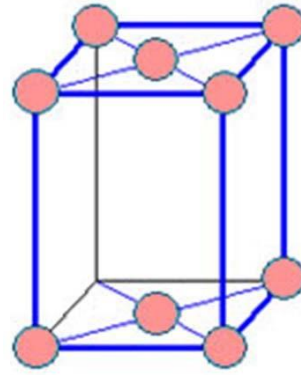

Base-centered

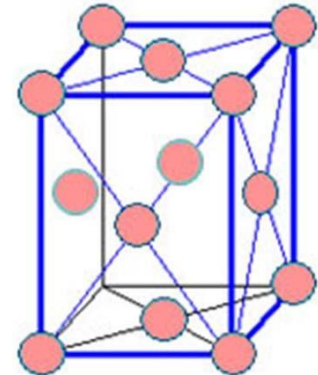

Face-centered

Monoclinic: $a \neq b \neq c$, $\alpha = \gamma = 90^\circ \neq \beta$

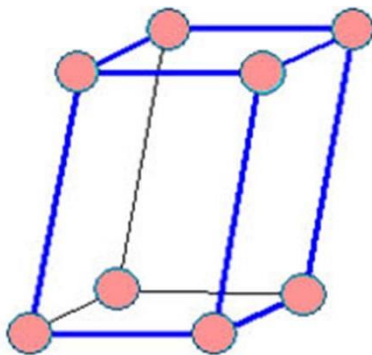

Simple
monoclinic

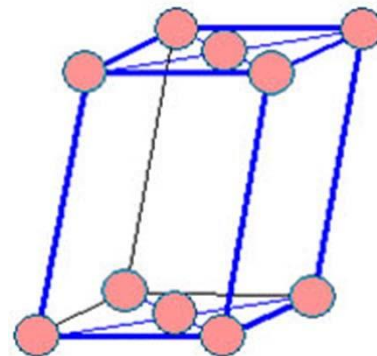

Base-centered
monoclinic

Crystal Systems

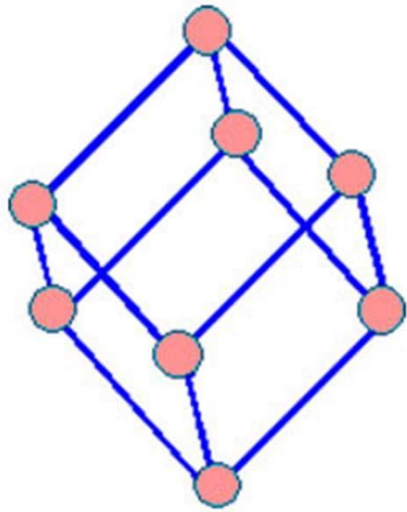

Rhombohedral
 $a = b = c$
 $\alpha = \beta = \gamma \neq 90^\circ$

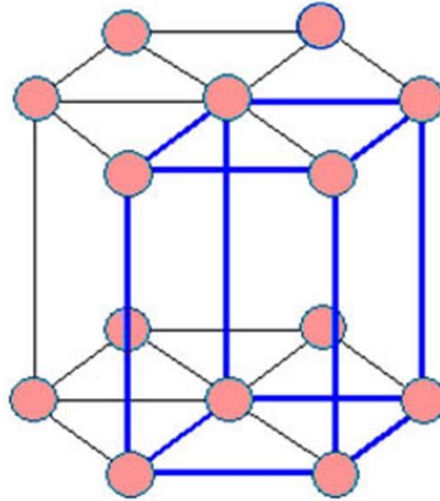

Hexagonal
 $a = b \neq c$
 $\alpha = \beta = 90^\circ \gamma = 120^\circ$

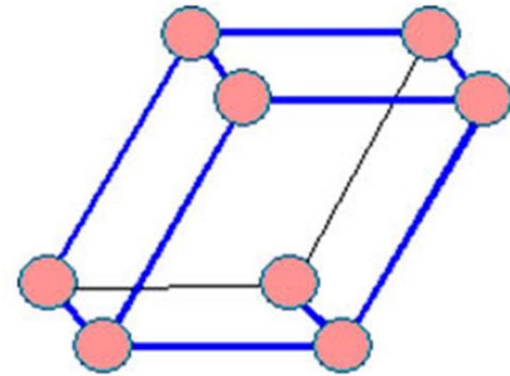

Triclinic
 $a \neq b \neq c$
 $\alpha \neq \beta \neq \gamma \neq 90^\circ$

Crystal Systems

Crystal system	Example
Triclinic	$K_2S_2O_8$, $K_2Cr_2O_7$
Monoclinic	As_4S_4 , KNO_2 , $CaSO_4 \cdot 2H_2O$, β -S
Rhombohedral	Hg, Sb, As, Bi, $CaCO_3$
Hexagonal	Zn, Co, Cd, Mg, Zr, NiAs
Orthorhombic	Ga, Fe_3C , α -S
Tetragonal	In, TiO_2 , β -Sn
Cubic	Au, Si, Al, Cu, Ag, Fe, NaCl

Point Coordinates

Position of any point in a unit cell is given by its coordinates or distances from the x, y and z axes in terms of the lattice vectors a, b and c.

Thus the point located at $a/2$ along x axis, $b/3$ along y axis and $c/2$ along z axis, as shown in the figure below, has the

coordinates $\frac{1}{2} \frac{1}{3} \frac{1}{2}$

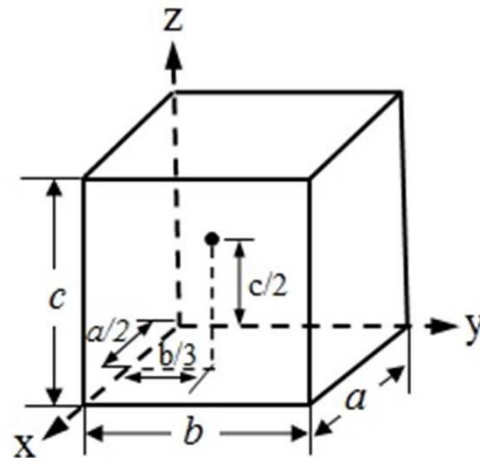

Crystal Planes

Miller Indices

Planes in a crystal are described by notations called Miller indices

- ❖ Miller indices of a plane, indicated by $h k l$, are given by the reciprocal of the intercepts of the plane on the three axes.
- ❖ The plane, which intersects X axis at 1 (one lattice parameter) and is parallel to Y and Z axes, has Miller indices $h = 1/1 = 1$, $k = 1/\infty = 0$, $l = 1/\infty = 0$. It is written as $(hkl) = (100)$.
- ❖ Miller indices of some other planes in the cubic system are shown in the figures in the next slide

Crystal Planes

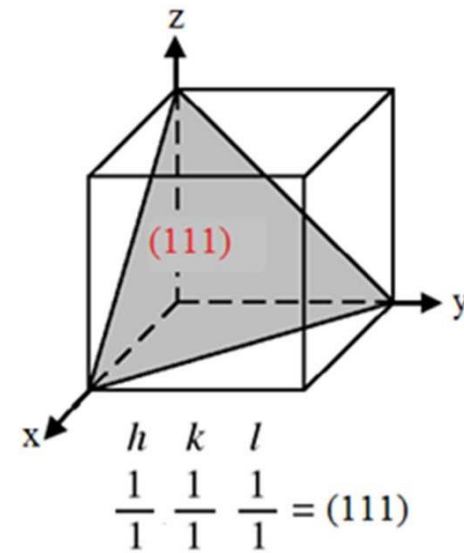
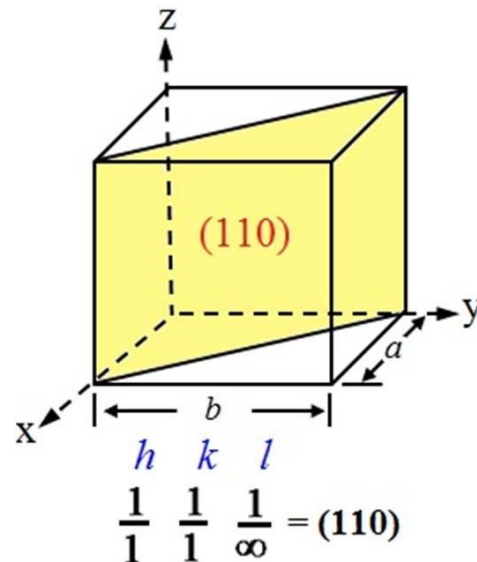
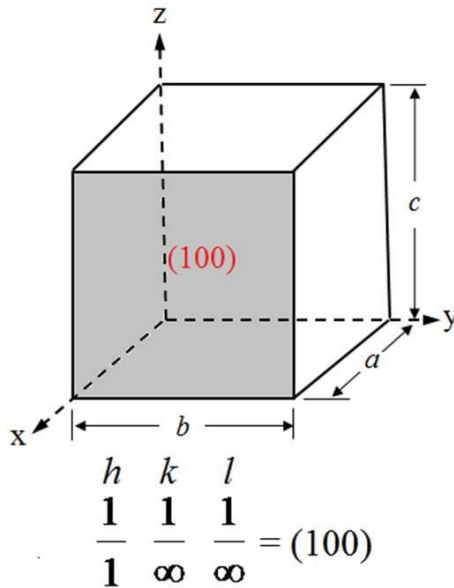

To find the Miller Indices of a plane, follow these steps:

- Determine the intercepts of the plane along the crystal axes
- Take the reciprocals
- Clear fractions
- Reduce to lowest terms and enclose in brackets ()

Ex: Intercepts on a, b, c : $\frac{3}{4}, \frac{1}{2}, \frac{1}{4}$ (h k l) = $(\frac{4}{3}, 2, 4) = (2 \ 3 \ 6)$

Crystal Planes

Planes can also have negative intercept e.g. 1, -1/2, 1

$h\ k\ l = 1\ -2\ 1$. This is denoted as $(\bar{1}21)$

Family of planes $\{hkl\}$

Planes having similar indices are equivalent, e.g. faces of the cube (100), (010) and (001). This is termed as a family of planes and denoted as $\{100\}$ which includes all the (100) combinations including negative indices. Some other equivalent planes are shown in the next slide.

Equivalent Planes

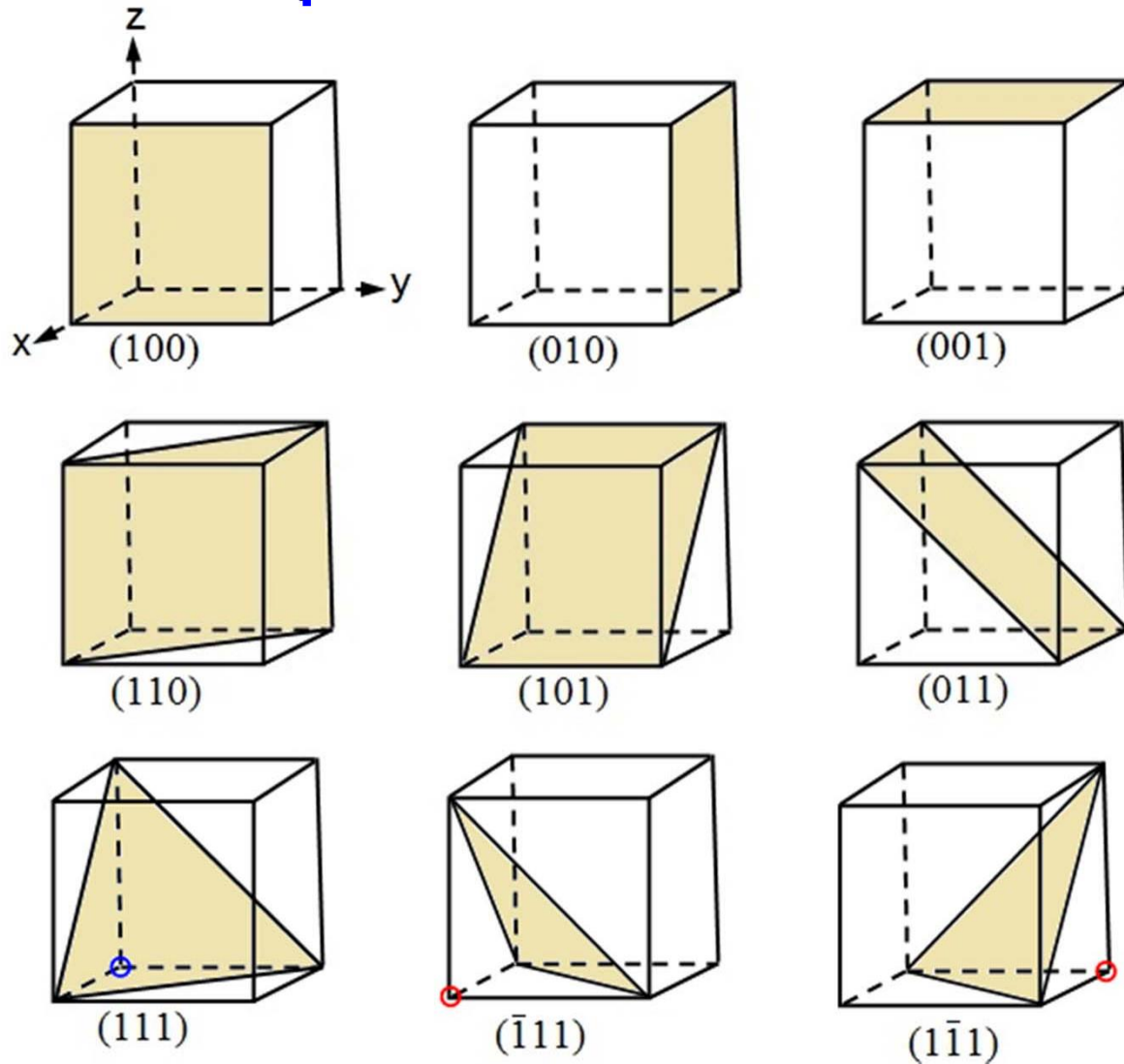

Note the shift of origin from blue to red circle for the negative indices

Planes in Hexagonal system

- In the cubic system all the faces of the cube are equivalent, that is, they have similar indices.
- However, this is not the case in the hexagonal system. The six prism faces for example have indices $(1\ 0\ 0)$, $(0\ 1\ 0)$, $(\bar{1}\ 1\ 0)$, $(\bar{1}\ 0\ 0)$, $(0\ \bar{1}\ 0)$, $(1\ \bar{1}\ 0)$, which are not same.

In order to address this, a fourth axis (a_3) which is opposite to the vector sum of a_1 and a_2 is used and a corresponding fourth index i is used along with hkl . Therefore the indices of a plane is given by $(hkil)$ where $i = -(h+k)$. Sometime i is replaced with a dot and written as $(h\ k\ .\ l)$

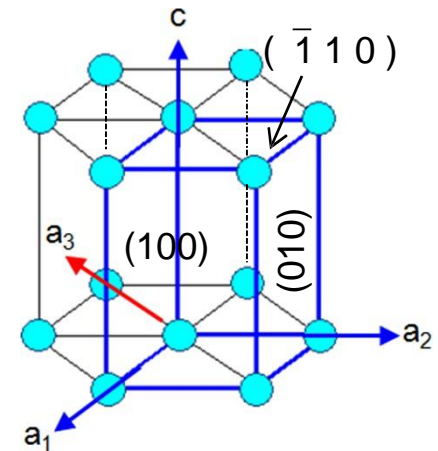

Planes in Hexagonal system

The indices of six faces now become $(1\ 0\ \bar{1}\ 0)$, $(0\ 1\ \bar{1}\ 0)$, $(\bar{1}\ 1\ 0\ 0)$, $(\bar{1}\ 0\ 1\ 0)$, $(0\ \bar{1}\ 1\ 0)$, $(1\ \bar{1}\ 0\ 0)$ which are now equivalent and belong to the $\{1\ 0\ \bar{1}\ 0\}$ family of planes.

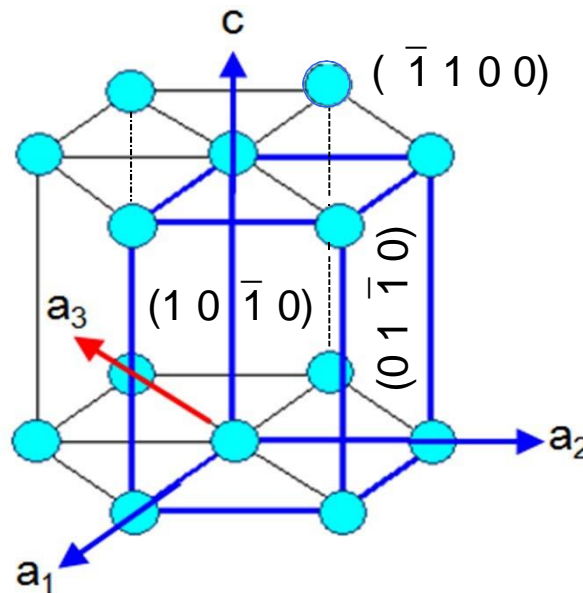

Interplanar spacing

The spacing between planes in a crystal is known as interplanar spacing and is denoted as d_{hkl}

In the cubic system spacing between the (hkl) planes is given as

$$\frac{1}{d^2} = \frac{1}{a^2} (h^2 + k^2 + l^2)$$

For example, d_{hkl} of {111} planes $d_{111} = \frac{a}{\sqrt{3}}$

In Tetragonal system $\frac{1}{d^2} = \frac{1}{a^2} (h^2 + k^2) + \frac{1}{c^2} l^2$

In Orthorhombic system $\frac{1}{d^2} = \frac{1}{a^2} h^2 + \frac{1}{b^2} k^2 + \frac{1}{c^2} l^2$

In Hexagonal system $\frac{1}{d^2} = \frac{4}{3a^2} (h^2 + k^2) + \frac{1}{c^2} l^2$

Crystal Directions

The directions in a crystal are given by specifying the coordinates (u, v, w) of a point on a vector (r_{uvw}) passing through the origin. $r_{uvw} = ua + vb + wc$. It is indicated as $[uvw]$. For example, the direction $[110]$ lies on a vector r_{110} whose projection lengths on x and y axes are one unit (in terms of unit vectors a and b).

Directions of a form or family like $[110]$, $[101]$, $[011]$ are written as $\langle 110 \rangle$

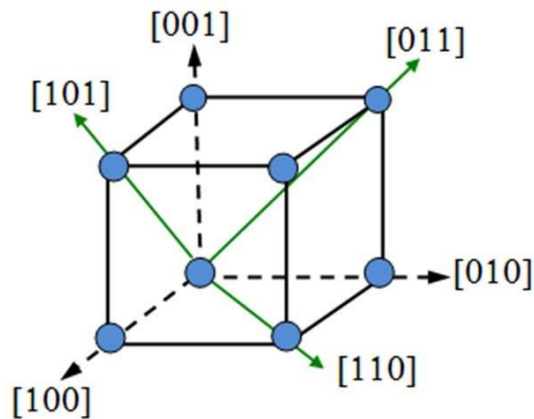

$\langle 100 \rangle$ and $\langle 110 \rangle$ family

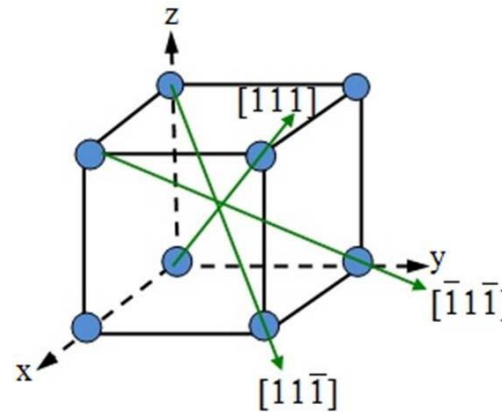

$\langle 111 \rangle$ family

Crystal Directions

- The line which passes through uvw will also pass through $2u2v2w$ and $\frac{1}{2}u \frac{1}{2}v \frac{1}{2}w$. Hence $[uvw]$, $[2u2v2w]$ and $[\frac{1}{2}u \frac{1}{2}v \frac{1}{2}w]$ are same and written as $[uvw]$.
- Fractions are converted in to integers (as shown in the figure below) and reduced to lowest terms.

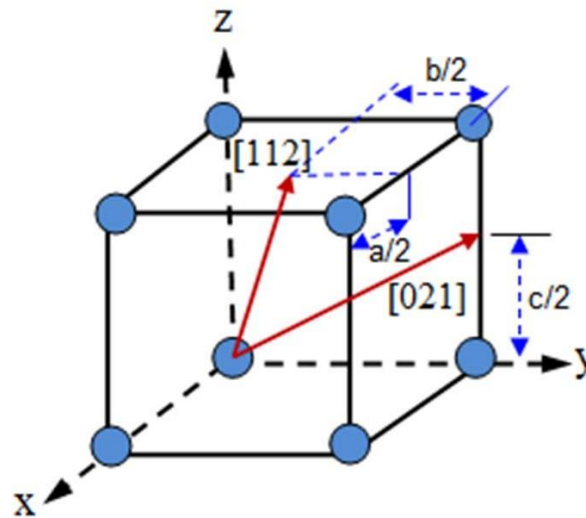

Crystal Directions

To determine a direction of a line in the crystal:

- ❑ Find the coordinates of the two ends of the line and subtract the coordinates (Head – Tail) OR draw a line from the origin parallel to the line and find its projection lengths on x, y and z axis in terms of the unit vectors a , b and c .
- ❑ Convert fractions, if any, in to integers and reduce to lowest term.
- ❑ Enclose in square brackets [uvw]

Directions in Hexagonal Crystal

Like planes, directions in the hexagonal system are also written in terms of four indices as $[uvtw]$.

If $[UVW]$ are indices in three axes then it can be converted to four-axis indices $[uvtw]$ using the following relations.

$$U = u - t \quad V = v - t \quad W = w$$

$$u = (2U - V)/3 \quad v = (2V - U)/3 \quad t = -(u + v) = -(U + V)/3$$

$$w = W$$

$$\text{Ex: } [100] = [2 \bar{1} \bar{1} 0], \quad [210] = [1 0 \bar{1} 0]$$

Relationship between direction and planes

In the cubic system planes and directions having same indices are perpendicular to each other i.e. if $[uvw]$ direction is perpendicular to (hkl) plane then $h = u, k = v$ and $l = w$
Ex: $\{100\}$ planes and $\langle 100 \rangle$ directions are perpendicular to each other.

If $[uvw]$ direction is parallel to (hkl) , that is if $[uvw]$ lies in the plane (hkl) then $hu + kv + lw = 0$. For example, $[\bar{1} 1 0]$ lies in the plane (111) since $1.(-1) + 1.1 + 1.0 = 0$

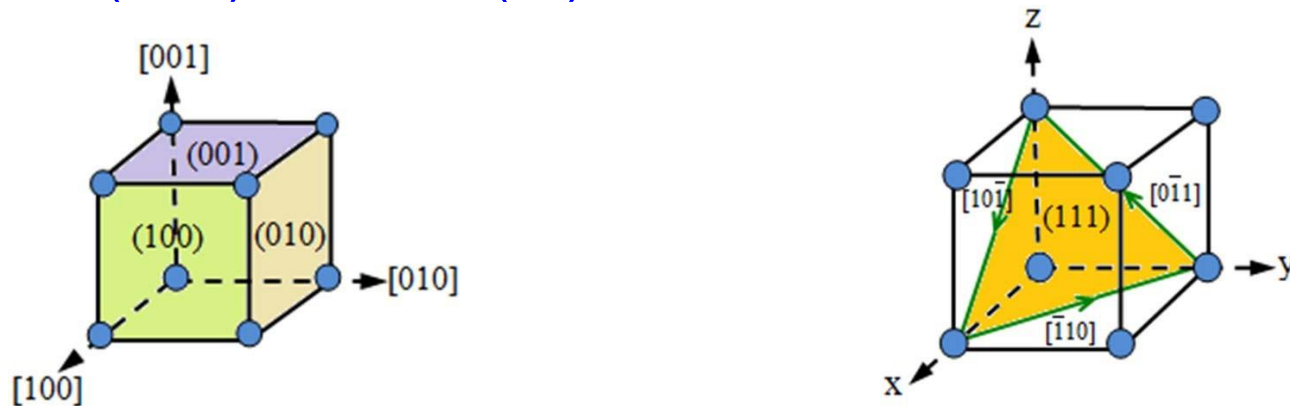

Coordination number

Coordination number is the number of nearest neighbor to a particular atom in the crystal

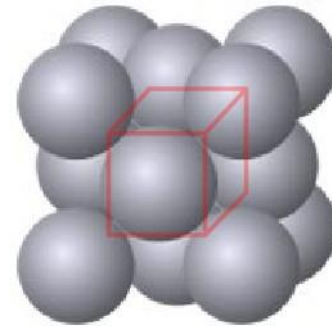
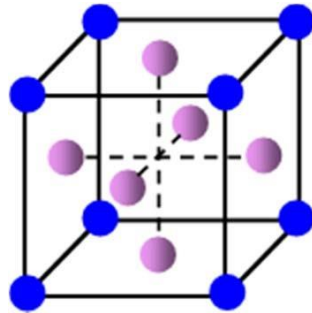
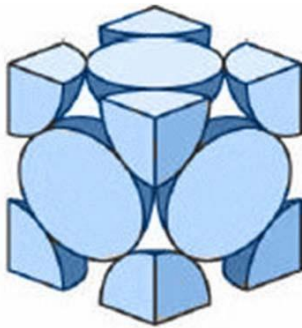

In the FCC lattice each atom is in contact with 12 neighbor atoms. **FCC coordination number $Z = 12$**

For example, the face centered atom in the front face is in contact with four corner atoms and four other face-centered atoms behind it (two sides, top and bottom) and is also touching four face-centered atoms of the unit cell in front of it.

Coordination number

The coordination number of BCC crystal is 8.

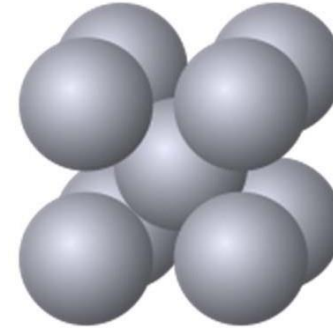
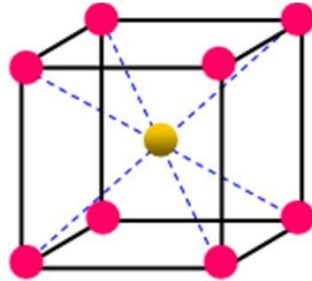
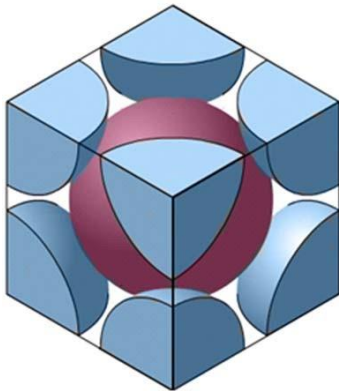

The body centered atom is in contact with all the eight corner atoms. Each corner atom is shared by eight unit cells and hence, each of these atoms is in touch with eight body centered atoms.

Coordination number

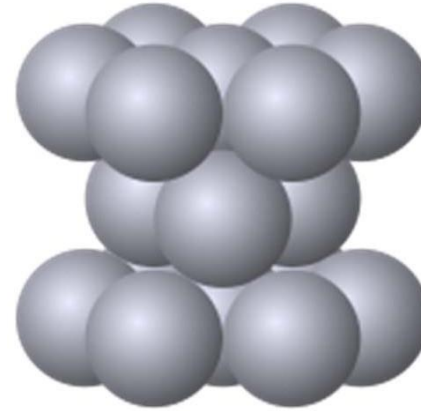
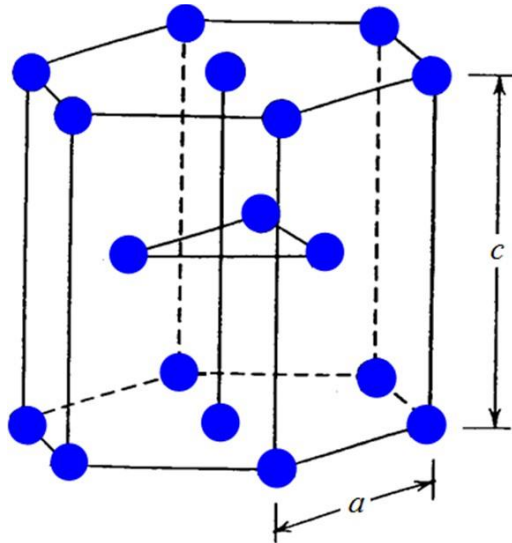

In Hexagonal lattice $Z = 12$. The center atom of the top face is in touch with six corner atoms, three atoms of the mid layer and other three atoms of the mid layer of the unit cell above it.

Atomic packing factor

Atomic packing factor (APF) or packing efficiency indicates how closely atoms are packed in a unit cell and is given by the ratio of volume of atoms in the unit cell and volume of the unit cell

$$F = \frac{\text{Volume of atoms in the unit cell}}{\text{Volume of the unit cell}}$$

Atomic packing factor

FCC lattice

In the FCC unit cell effective number of atoms = 8 corner atoms \times (1/8) (each atom is shared by 8 unit cells) + 6 face-centered atoms \times 1/2 (each shared by two unit cells) = 4

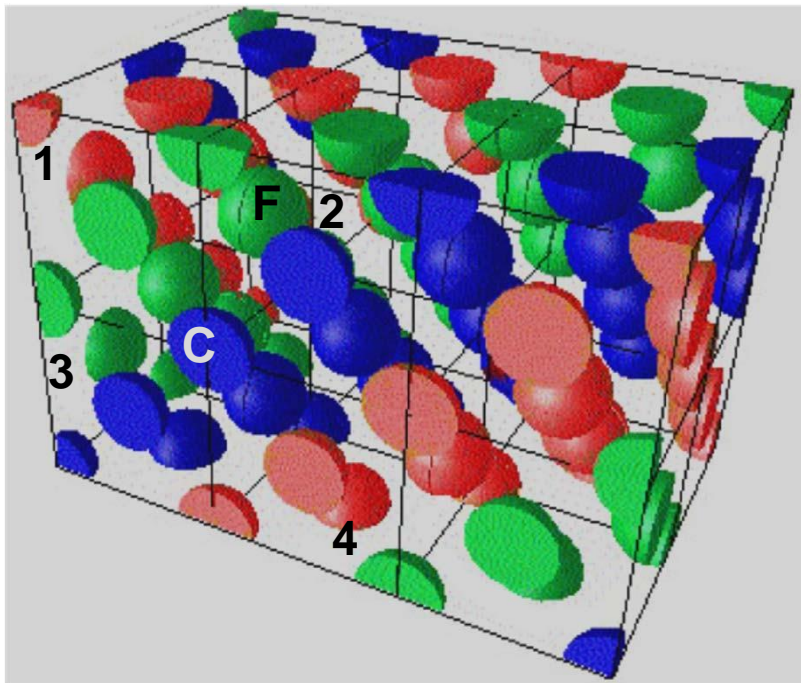

The corner atom **C** is shared by unit cells 1, 2, 3, 4 and four more in front of each of them. The face-centered atom, **F** is shared between cells 1 and 2.

[Click here for animation](#)

Atomic packing factor

FCC lattice

Considering the atoms as hard spheres of radius R

$$n \cdot v = 4 \times \frac{4}{3} \pi R^3$$

The relation between R and the FCC cell side a as shown in the figure below is $\sqrt{2}a = 4R$

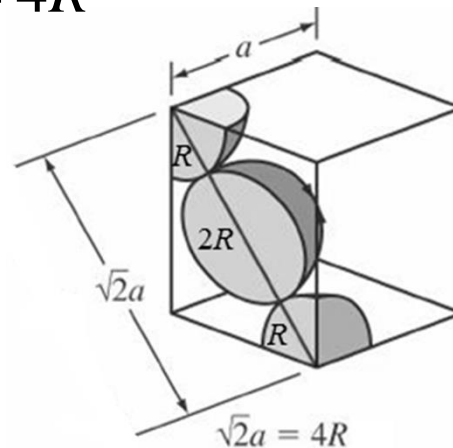
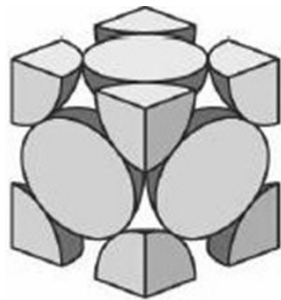

$$APF(FCC) = \frac{4 \times \frac{4}{3} \pi R^3}{a^3} = \frac{16 \times 2\sqrt{2}\pi a^3}{3 \times 64a^3} = 0.74$$

Atomic packing factor

BCC

For BCC crystals effective number of atoms per unit cell is $8 \times 1/8 + 1 = 2$ and the relation between R and a is

$$\sqrt{3}a = 4R$$

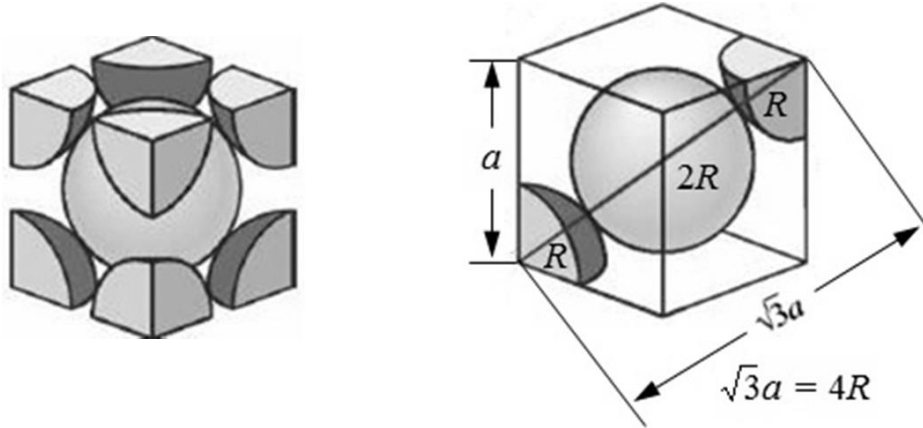

$$APF(BCC) = \frac{2 \times \frac{4}{3} \pi R^3}{a^3} = \frac{8 \times 3\sqrt{3}\pi a^3}{3 \times 64a^3} = 0.68$$

Atomic packing factor

Hexagonal lattice

In the Hexagonal unit cell, number of atoms = 12 corner atoms \times $1/6$ (shared by six unit cells) + Two face atoms \times $1/2$ + 3 interior = 6.

$$2R = a$$

Unit cell volume = $(6 \times \frac{1}{2} \times a \times h) \times c = (3 \times a \times a \sin 60^\circ) \times c$
 $= 3a^2 c \sin 60^\circ$

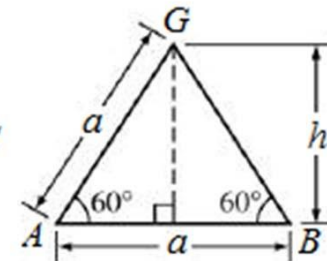
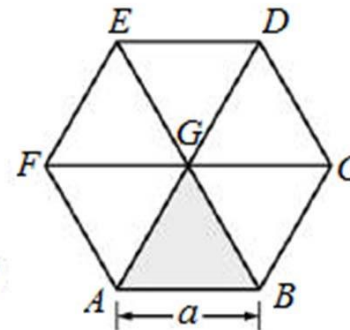
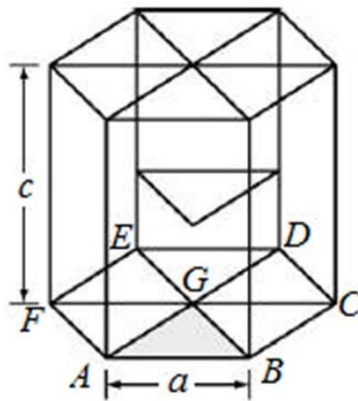
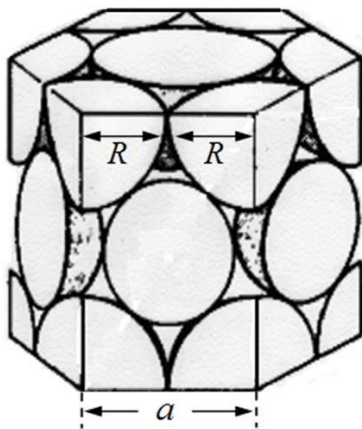

Atomic packing factor

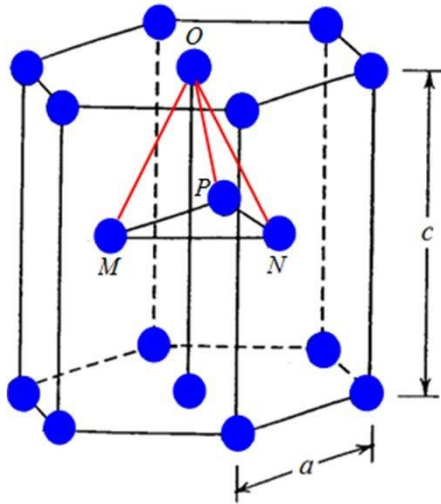

The face-centered atom and the three mid-layer atoms form a tetrahedron MNOP which has sides equal to a (as atoms at vertices touch each other) and height of $c/2$. Using this tetrahedron it can be shown that for an ideal hexagonal crystal c/a ratio = 1.633

$$APF(HCP) = \frac{6 \times \frac{4}{3} \pi R^3}{3a^2 c \sin 60^\circ} = \frac{8\pi R^3}{3 \times 8 \times 1.414 a^3} = 0.74$$

Planar density

Planar density (PD) refers to density of atomic packing on a particular plane.

$$PD = \frac{\text{Number of atoms in the plane}}{\text{Area of the plane}}$$

For example, there are 2 atoms ($1/4 \times 4$ corner atoms + $1/2 \times 2$ side atoms) in the $\{110\}$ planes in the FCC lattice. Planar density of $\{110\}$ planes in the FCC crystal

$$PD_{(110)} = \frac{2}{a\sqrt{2}a} = \frac{\sqrt{2}}{a^2}$$

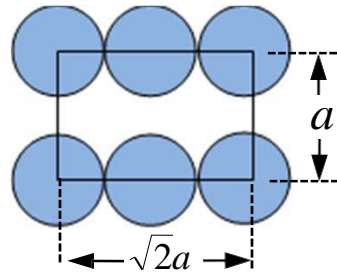
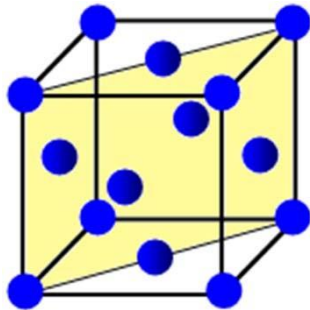

Planar density

In the {111} planes of the FCC lattice there are 2 atoms (1/6 x 3 corner atoms + 1/2 x 3 side atoms). Planar density of {111} planes in the FCC crystal

$$PD_{(111)} = \frac{2}{\frac{1}{2} \sqrt{2}a \times \sqrt{2}a \frac{\sqrt{3}}{2}} = \frac{4}{\sqrt{3}a^2}$$

This is higher than {110} and any other plane. Therefore, {111} planes are most densely packed planes in the FCC crystal

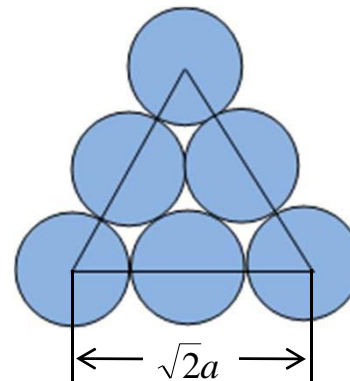
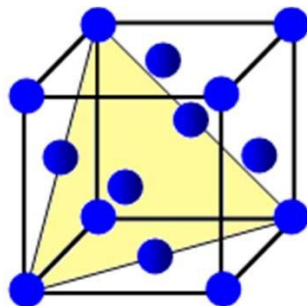

Linear Density

Linear density (LD) is the number of atoms per unit length along a particular direction

$$LD = \frac{\text{Number of atoms in the direction}}{\text{Length of the direction}}$$

$\langle 110 \rangle$ directions in the FCC lattice have 2 atoms (1/2 x 2 corner atoms + 1 center atom) and the length is $\sqrt{2}a$

$$LD_{[110]} = \frac{2}{\sqrt{2}a} = \frac{\sqrt{2}}{a}$$

This is the most densely packed direction in the FCC lattice

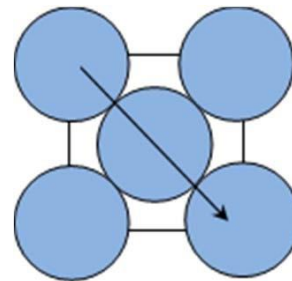
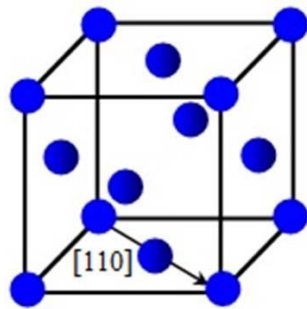

Close-Packed Structure

- FCC and hexagonal crystal structures are most highly packed with packing efficiency of 74% (APF= 0.74). Such structures can be described in terms of close-packed atomic planes.
- In FCC, $\{111\}$ planes are close-packed and the basal plane (0001) is the close-packed one in hexagonal close-packed (HCP) system. Therefore, both of these structures can be generated by stacking of these planes. A portion of such a stack is shown in the picture below.

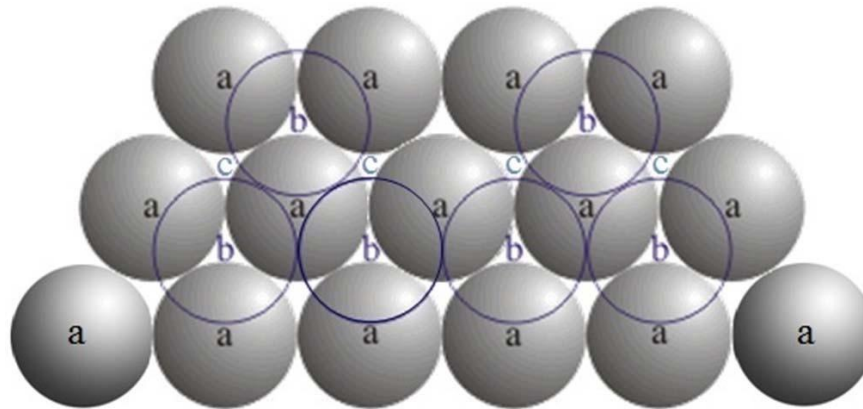

Close-Packed Structure

- There are two types of voids between the atoms – vertex up (*b*), and vertex down (*c*). The atoms in the next layer sit on the *b* sites (See animation below).
- In FCC, atoms in the third layer sit over the *c* sites and this repeats giving rise to ABC ABC ABC type of stacking.

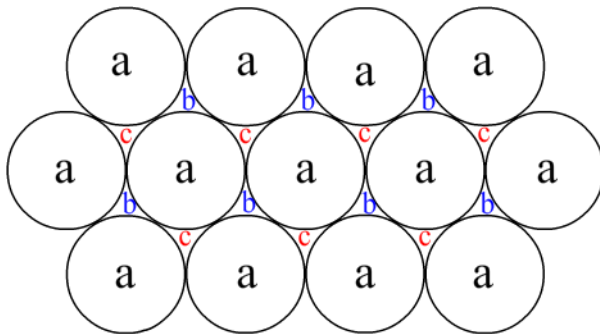

Close-Packed Structure

- In HCP system, centers of atoms of the third layer lie directly over centers of atoms of the first layer (a positions) giving rise to AB AB AB type of stacking.

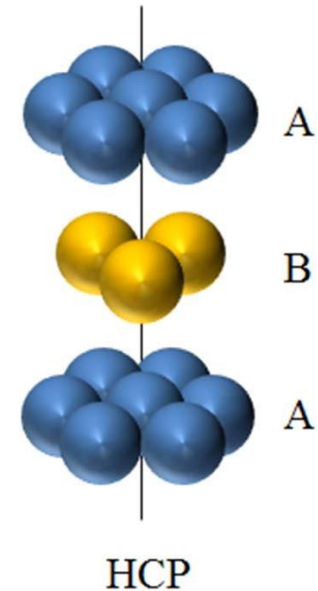
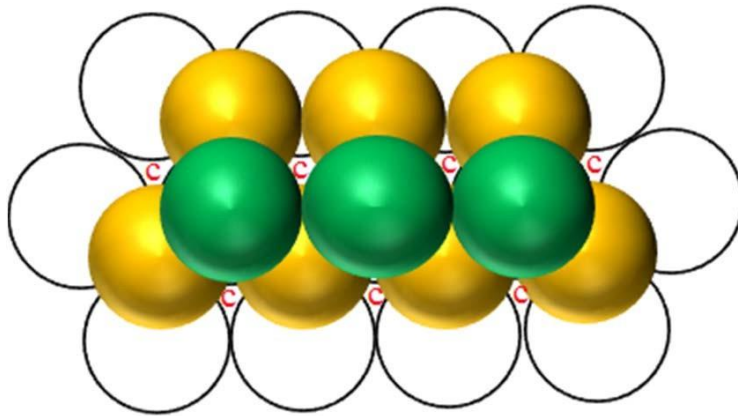

Structure-Property correlation

Aluminium (Al) is ductile while iron (Fe) and magnesium (Mg) are not. This can be explained from their crystal structures.

Al is FCC where as Fe is BCC and Mg is HCP.

Plastic deformation in metals takes place mainly by a process called slip. Slip can broadly be visualized as sliding of crystal planes over one another. Slip occurs on most densely packed planes in the most closely packed directions lying on that plane.

The slip plane and the direction together is called a **Slip system**

Structure-Property correlation

□ In FCC, $\{111\}$ planes are close-packed and there are four unique $\{111\}$ planes. Each of these planes contains three closely packed $\langle 110 \rangle$ directions. Therefore, there are $4 \times 3 = 12$ slip systems

□ In HCP, the basal plane, (0001) is the close-packed and it contains three $\langle 1\ 1\ \bar{2}\ 0 \rangle$ directions. Hence, number of slip system = $1 \times 3 = 3$

□ Slip in more number of slip systems allows greater plastic deformation before fracture imparting ductility to FCC materials

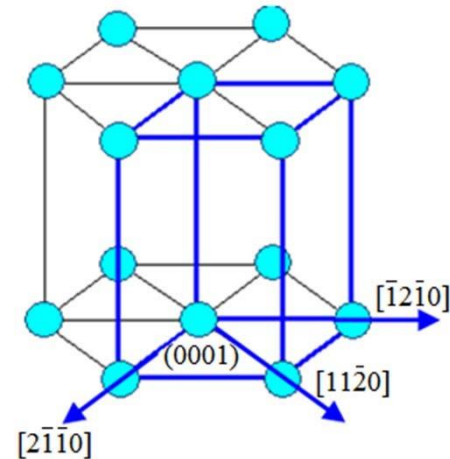
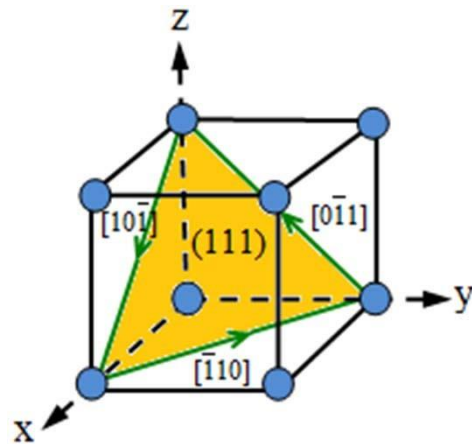

Structure-Property correlation

- ❑ Close-packed planes are also planes with greatest interplanar spacing and this allows slip to take place easily on these planes.
- ❑ BCC structure on the other hand has 48 possible slip systems. However, there is no close-packed plane. Hence, plastic deformation before fracture is not significant. Slip might occur in $\{110\}$, $\{112\}$ and $\{123\}$ planes in the $\langle 111 \rangle$ directions.

Evaluation

At the end of this chapter on crystallography, one should be able to

- Understand Space lattice, Unit cells, 7 crystal structure and 14 Bravais lattices.
- Understand atomic arrangement and packing in different unit cells.
- Derive point coordinates
- Find out miller indices of crystallographic planes and directions.
- Correlate some properties to crystal structure.

Web References

<http://www.youtube.com/watch?v=qh29mj6uXoM&feature=relmfu>

<http://www.youtube.com/watch?v=8zWySdeXB0M&feature=relmfu>

<http://www.youtube.com/watch?v=Rm-i1c7zr6Q&feature=related>

<http://www.youtube.com/watch?v=PWQ89UoxOK8&feature=related>

<http://www.youtube.com/watch?v=mQy2CdKYqX0&feature=related>

Key words: Symmetry; Space lattice; Crystal structure; Miller indices; Close pack structure; Slip system

Examples

Ex. 1: Theoretical density calculation from crystal structure.

$$\text{Theoretical density, } \rho = \frac{nA}{V_C N_A}$$

n = number of atoms in the unit cell

A = atomic weight

V_C = volume of unit cell

N_A = Avogadro's number (6.023×10^{23} atoms/mol)

Calculate the theoretical density of Al.

Al is FCC, lattice parameter, $a = 4.05 \text{ \AA}$, $n = 4$.

Atomic weight of Al is 26.98 g/mol

$$\rho = \frac{4 \times 26.98}{(4.05 \times 10^{-8})^3 \times 6.023 \times 10^{23}} = 2.697 \text{ g/cm}^3$$

Examples

Ex. 2: Show the point having coordinates $1/2, 1, 1/3$.

Solution: Select one of the corners of the unit cell as the origin. Move $a/2$ from the origin along the x axis and mark this point. From this point move b units along the y axis and then $c/3$ units along the z axis.

Ex. 3: Draw the plane $(3 \bar{1} 2)$ in a cubic unit cell.

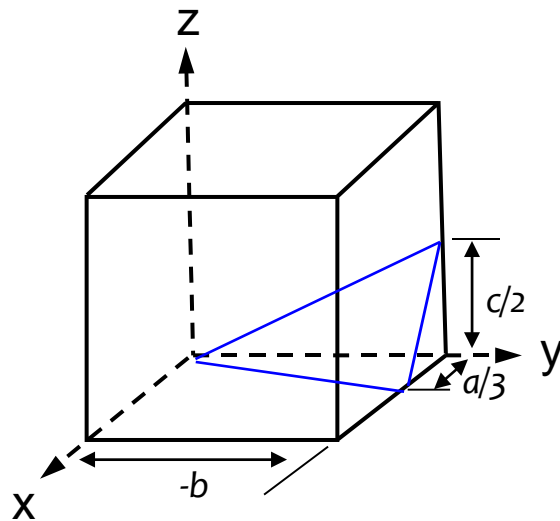

Examples

Ex. 4: Draw the directions $[236]$ and $[203]$ and $[2\bar{1}1]$ in a cubic unit cell.

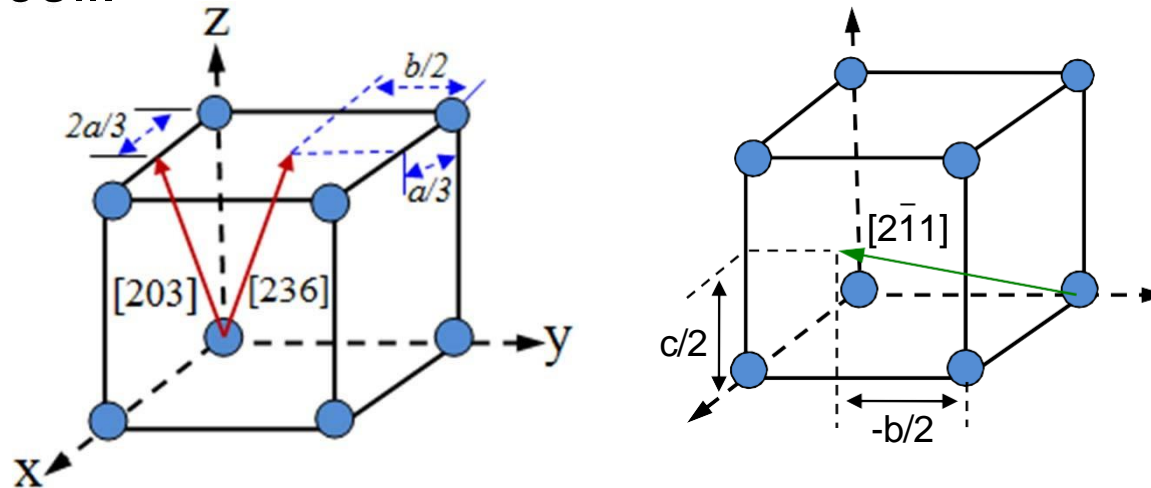

Ex. 5: The atomic radius of Fe is 0.124 nm. Find the lattice parameter of Fe.

Solution: Fe is BCC at room temperature. Therefore,

$$\sqrt{3} a = 4 r \quad \text{and} \quad a = \frac{4 r}{\sqrt{3}} = \frac{4 \times 0.124}{\sqrt{3}} = 0.286 \text{ nm}$$

Quiz

1. Show that only four types of rotational symmetry are possible.
2. Why it is not possible to have 5, 7 or higher order symmetry in crystallography?
3. What is point group? How many point-groups are possible?
4. Find out the Hermann-Mauguin symbol for a cube.
5. For a point at xyz write a translation, a reflection and an inversion operation.
5. What is unit cell? What is lattice parameter?
6. What is Bravais lattice? How are the Bravais lattices obtained from the primitive cell? How many types of Bravais lattices are there?
7. What is the effective number of atoms in a simple cubic unit cell?

Quiz

8. What is coordination number (CN)? Show that CN for FCC and HCP structure is 12 while it is 8 for BCC.
9. Show that packing efficiency of FCC is 74% and that of BCC is 68%.
10. Show that the ideal c/a ratio in a hexagonal unit cell is 1.633 and calculate the packing efficiency.
11. What are the coordinates of the center atom in the BCC unit cell.
12. What is miller index? How is it obtained?
13. Draw the planes $(\bar{1} \bar{1} 0)$, $(1 \bar{2} 1)$, $(2 \bar{3} 4)$, $(\bar{1} 12)$ and directions $[1 1 \bar{1}]$, $[123]$, $[120]$, $[1 \bar{2} 1]$ in a cubic unit cell.
14. Why it is necessary to include a fourth miller index in the hexagonal system?
15. Convert the directions $[112]$, $[1 \bar{2} 3]$, $[110]$, $[111]$, $[130]$ to four indices in a hexagonal lattice.

Quiz

16. What is family of planes? Draw the $\{111\}$ family of planes in cubic system?
17. What is linear density? What is planar density?
18. Find the planar of density $\{111\}$ planes and linear density of $\langle 110 \rangle$ directions in FCC system.
19. What is the linear density of $\langle 111 \rangle$ directions in the BCC crystal.
20. What is interplanar spacing? Find the interplanar spacing of the vertical planes in the HCP system?
21. What is the stacking sequence of FCC and HCP crystals?
22. What is slip system?
23. Why FCC metals are ductile while BCC and HCP metals are not?
24. Calculate the theoretical density of Cu from its crystal structure.

Quiz

25. Lattice constant of Al is 4.05 Å. What is the atomic radius of Al?
26. Calculate the theoretical density of Mg, Cu and Fe and compare them to the standard values.
27. A metal has a density of 10.22 g/cc, atomic weight of 95.94 and atomic radius of 0.136 nm. Is it BCC or FCC?
28. Calculate the volume of the unit cell of Zn crystal. a and c of Zn are 266.5 pm and 494.7 pm respectively.
29. Calculate the planar density of $\{110\}$ planes in α -Fe (BCC) crystal. $a = 0.287$ nm.
30. Calculate the linear density of $[110]$ direction in a Cu crystal. $a = 0.361$ nm.

Perovskites

The terms "perovskite" and "perovskite structure" are often used interchangeably. Technically, a perovskite is a type of mineral that was first found in the Ural Mountains and named after Lev Perovski who was the founder of the Russian Geographical Society. A perovskite structure is any compound that has the same structure as the perovskite mineral.

True perovskite (the mineral) is composed of calcium, titanium and oxygen in the form CaTiO_3 . Meanwhile, a perovskite structure is anything that has the generic form ABX_3 and the same crystallographic structure as perovskite (the mineral). However, since most people in the solar cell world aren't involved with minerals and geology, perovskite and perovskite structure are used interchangeably.

The perovskite lattice arrangement is demonstrated below. As with many structures in crystallography, it can be represented in multiple ways. The simplest way to think about a perovskite is as a large atomic or molecular cation (positively-charged) of type A in the centre of a cube. The corners of the cube are then occupied by atoms B (also positively-charged cations) and the faces of the cube are occupied by a smaller atom X with negative charge (anion).

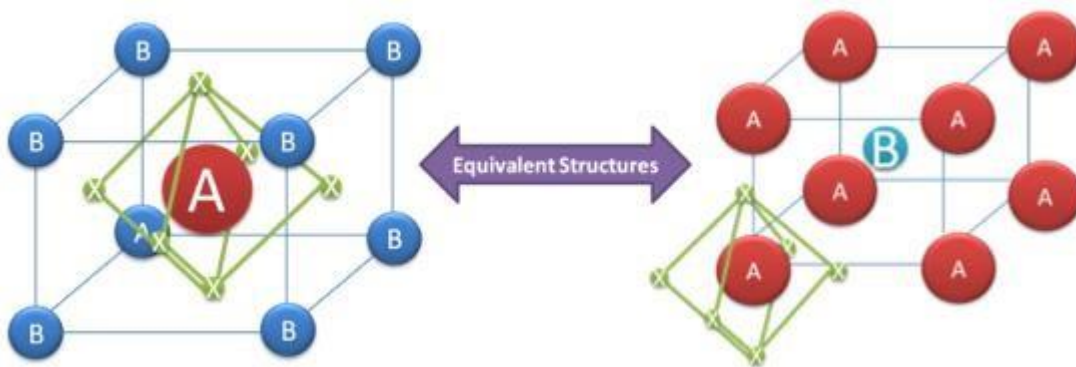

A generic perovskite crystal structure of the form ABX_3 . Note however that the two structures are equivalent – the left hand structure is drawn so that atom B is at the $\langle 0,0,0 \rangle$ position while the right hand structure is drawn so that atom (or molecule) A is at the $\langle 0,0,0 \rangle$ position. Also note that the lines are a guide to represent crystal orientation rather than bonding patterns.

Depending on which atoms/molecules are used in the structure, perovskites can have an impressive array of interesting properties including superconductivity, giant magnetoresistance, spin-dependent transport (spintronics) and catalytic properties. Perovskites therefore represent an exciting playground for physicists, chemists and material scientists.

In the case of perovskite solar cells, the most efficient devices so far have been produced with the following combination of materials in the usual perovskite form ABX_3 :

- A = An organic cation - methylammonium (CH_3NH_3)⁺
- B = A big inorganic cation - usually lead(II) (Pb^{2+})
- X_3 = A slightly smaller halogen anion – usually chloride (Cl^-) or iodide (I^-)

Since this is a relatively general structure, these perovskite-based devices can also be given a number of different names, which can either refer to a more general class of materials or a specific combination. As an example of this, we've created the below table to highlight how many names can be formed from one basic structure.

A	B	X_3
Organo	Metal	Trihalide (or trihalide)
Methylammonium	Lead	Iodide (or triiodide)
	Plumbate	Chloride (or trichloride)

Diamond Structure

Diamond Crystal Structure is a metastable allotrope of carbon where the each carbon atom is bonded covalently with other surrounding four carbon atoms and are arranged in a variation of the face centered cubic crystal structure called a diamond lattice. Diamond is a transparent crystal of tetrahedrally bonded carbon atoms (sp^3) that crystallizes into the diamond lattice which is a variation of the face centered cubic structure. Each carbon atom joins four other carbon atoms in regular tetrahedrons (triangular prisms). Based on the cubic form and its highly symmetrical arrangement of atoms, diamond crystals can develop into several different shapes, known as 'crystal habits'.

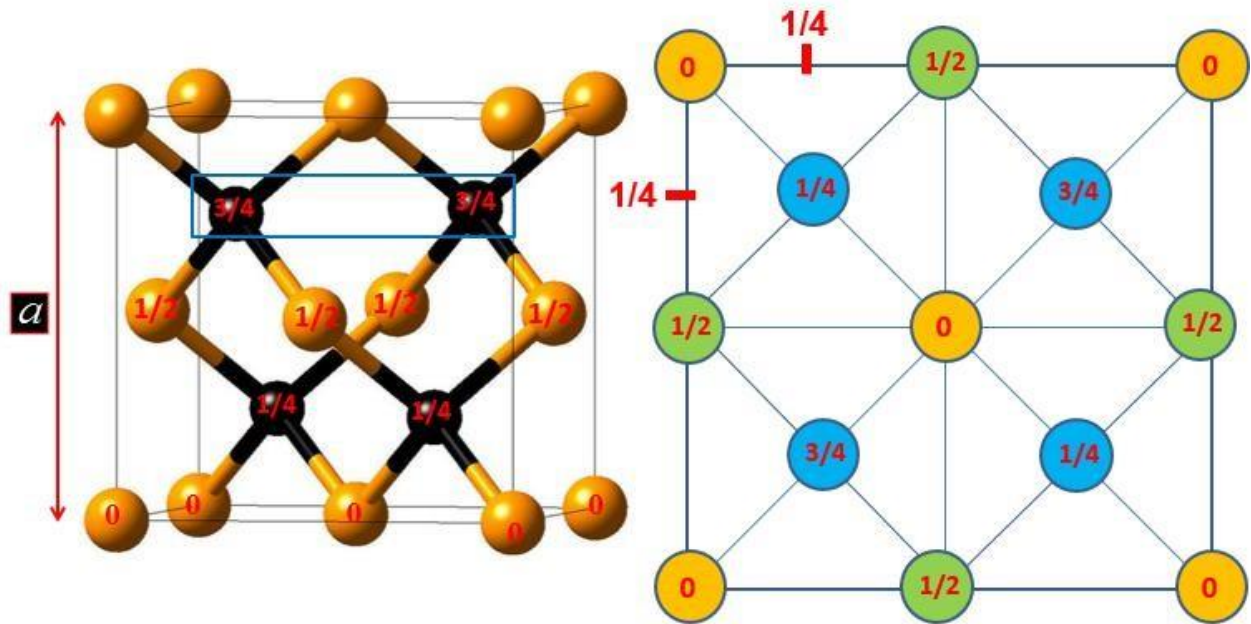

The number '0' and fractions ' $1/2$ ', ' $1/4$ ' and ' $3/4$ ' denote the height above the base.

Graphite Structure

Graphite is a greyish black opaque substance. It is lighter than diamond and is soft and slippery to touch. It conducts electricity. It is made up of carbon atoms only. The structure of graphite is very different from that of diamond. It consists of layers of carbon atoms or sheets of carbon atoms. Each carbon atom in a graphite layer is joined to three other carbon atoms by strong covalent bonds to form flat hexagonal rings. The various layers of carbon atoms in graphite are held together by weak van der Waals forces.

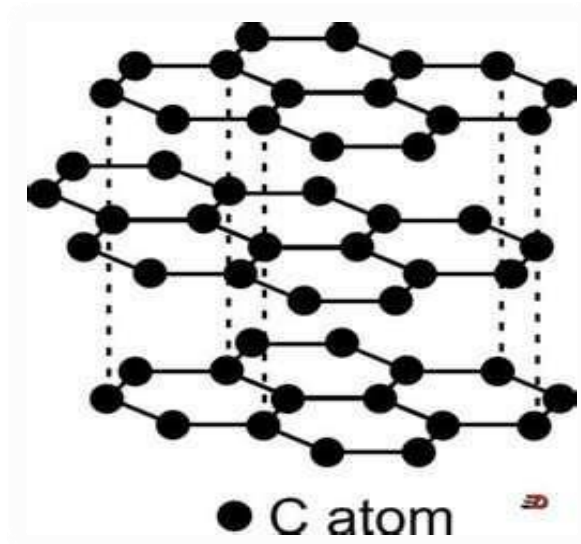

The structure of graphite is very different from that of diamond. It consists of layers of carbon atoms or sheet of carbon atoms. Each carbon atoms in a graphite layer is joined to three other carbon atoms by strong covalent bonds to form flat hexagonal rings. The various layers of carbon atoms in graphite are held together by weak van der waals forces. Due to the sheet like structure, graphite is comparatively soft substance. Graphite is good conductor of electricity because due to the presence of free electrons.

Uses of Graphite:

- Graphite can be used for lubricating those machine parts which operate at very high temperature.
- Graphite is used for making graphite electrodes in dry cells and electric arcs.
- Graphite is used for making the cores of our pencils called pencil leads.

Hexagonal Closed Packed Structure

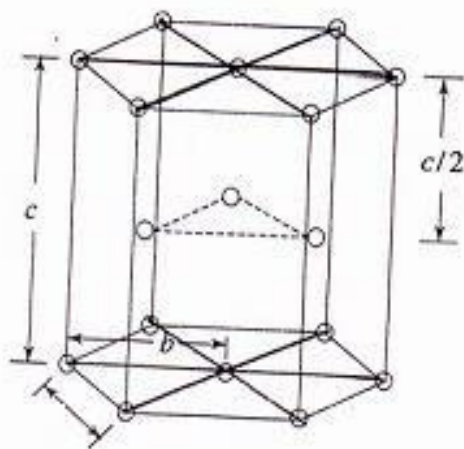
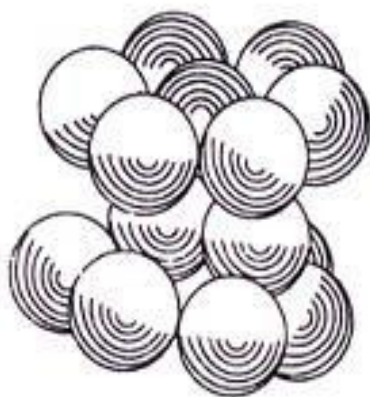

- It consists of three layers of atoms.
- The bottom layer has six corner atoms and one face centred atom.
- The middle layer has three full atoms.
- The upper layer has six corner atoms and one face centred atom.
- Each and every corner atom contributes $1/6$ of its part to one unit cell.
- The number of total atoms contributed by the corner atoms of both top and bottom layers is $1/6 \times 12 = 2$.

- The face centred atom contributes 1/2 of its part to one unit cell.
- Since there are 2 face centred atoms, one in the top and the other in the bottom layers, the number of atoms contributed by face centred atoms is $1/2 \times 2 = 1$.
- Besides these atoms, there are 3 full atoms in the middle layer.
- Total number of atoms present in an HCP unit cell is $2+1+3 = 6$.

CO-ORDINATION NUMBER (CN)

- The face centered atom touches 6 corner atoms in its plane.
- The middle layer has 3 atoms.
- There are three more atoms, which are in the middle layer of the unit cell.
- Therefore the total number of nearest neighbours is $6+3+3=12$.

ATOMIC RADIUS (R)

- Consider any two corner atoms.
- Each and every corner atom touches each other.

Therefore $a = 2r$. i.e., The atomic radius, $r = a/2$.

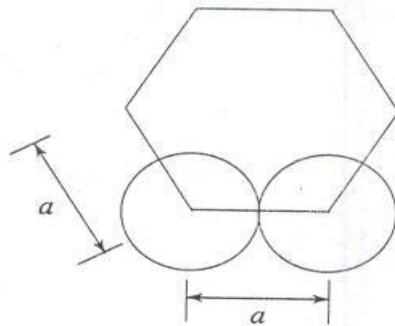

ATOMIC PACKING FACTOR (APF)

APF =

$$v = 6 \times \frac{4}{3} \pi r^3$$

Substitute $r = \frac{a}{2}$,

$$v = 6 \times \frac{4}{3} \pi \left(\frac{a}{2}\right)^3$$

$$v = \pi a^3$$

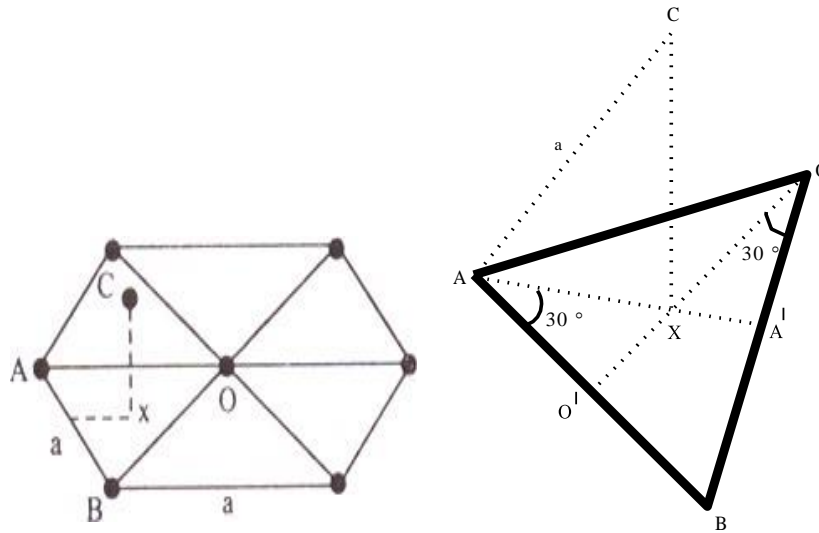

$AB = AC = BO = 'a'$. $CX =$ where $c \rightarrow$ height of the hcp unit cell.

Area of the base = $6 \times$ area of the triangle – ABO

$$= 6 \times \frac{1}{2} \times AB \times OO'$$

Area of the base = $6 \times \frac{1}{2} \times a \times OO'$

In triangle OBO' $\angle O'OB = 30^\circ$

$\cos 30^\circ =$

$$\therefore OO' = a \cos 30^\circ = a$$

Now, substituting the value of OO' ,

Area of the base = $6 \times 0.5 \times a \times 0.866 a$

$$= \frac{3\sqrt{3}a^2}{2}$$

$V =$ Area of the base \times height

CALCULATION OF c/a RATIO

In the triangle ABA' , $\angle A'AB = 30^\circ$

$$\cos 30^\circ = \frac{AA'}{AB}$$

$$\therefore AA' = AB \cos 30^\circ = a$$

But $AX = AA' =$

i.e. $AX = \frac{a}{\sqrt{3}}$

$$\frac{c^2}{4} = a^2 \begin{pmatrix} 1 & -1 \\ & 3 \end{pmatrix} \quad \frac{c^2}{a^2} = \frac{8}{3} \quad \frac{c}{a} = \sqrt{\frac{8}{3}}$$

Now substituting the value of c/a to calculate APF of an hcp unit cell,

$$APF = \frac{2\pi}{3\sqrt{3}} \sqrt{\frac{3}{8}}$$

$$= \frac{2\pi}{3\sqrt{3}} \frac{\sqrt{3}}{2\sqrt{2}}$$

$$\therefore APF = \frac{\pi}{3\sqrt{2}} = 0.74$$

Packing Fraction = 74%

IMPERFECTIONS
IN
CRYSTALS

IMPERFECTIONS IN CRYSTALS

➤ **ISSUES TO ADDRESS...**

- **How do defects affect material properties?**
- **What types of defects arise in solids?**
- **Are defects undesirable?**

Crystalline Imperfections

There is no such thing as a perfect crystal!

- Thermodynamically “impossible”
- *“defects” lower the energy of a crystal & make it more stable*
- always have vacancies and impurities, to some extent

Defect does not necessarily imply a bad thing

- addition of C to Fe to make steel
- addition of Cu to Ni to make thermocouple wires
- addition of Ge to Si to make thermoelectric materials
- addition of Cr to Fe for corrosion resistance
- introduction of grain boundaries to strengthen materials
- and so on

“Defect” (in this context) can be either desirable or undesirable.

In general, a defect simply refers to a disruption in the crystalline order of an otherwise periodic material.

Crystal imperfections are broadly classified into four major classes as below:

1) *Point defects (Zero dimensional)*

2) *Line defects (One dimensional)*

3) *Planar or surface defects (Two dimensional)*

4) *Volume defects*

1) Point Defects

- Atoms in solid possess vibrational energy, some atoms have sufficient energy to break the bonds which hold them in eqbm position. Hence once the atoms are free they give rise to **Point Defects**.

Classes of point defects:

1. Vacancy/Schottky
 2. Interstitial/Frenkel
- **Impurities**
 1. Substitution
 2. Interstitial

Vacancies

- A lattice position that is vacant because the atom is missing
- There are naturally occurring vacancies in all crystals
- The concentrations of vacancies increase with:
 - increasing temperature
 - decreasing activation energy

Vacancies

- -vacant atomic sites in a structure.

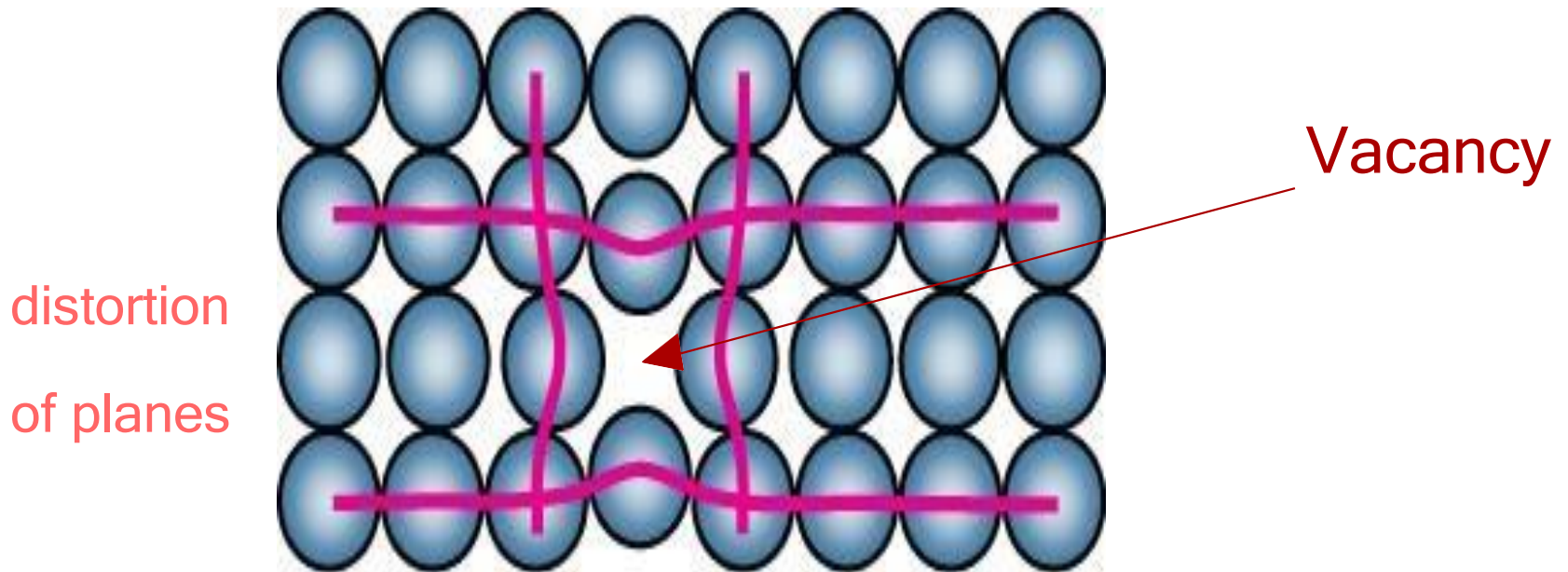

Self-Interstitial

- If the matrix atom occupies its own interstitial site, the defect is called Self Interstitial.
- Self-interstitials in metals introduce large distortions in the surrounding lattice.

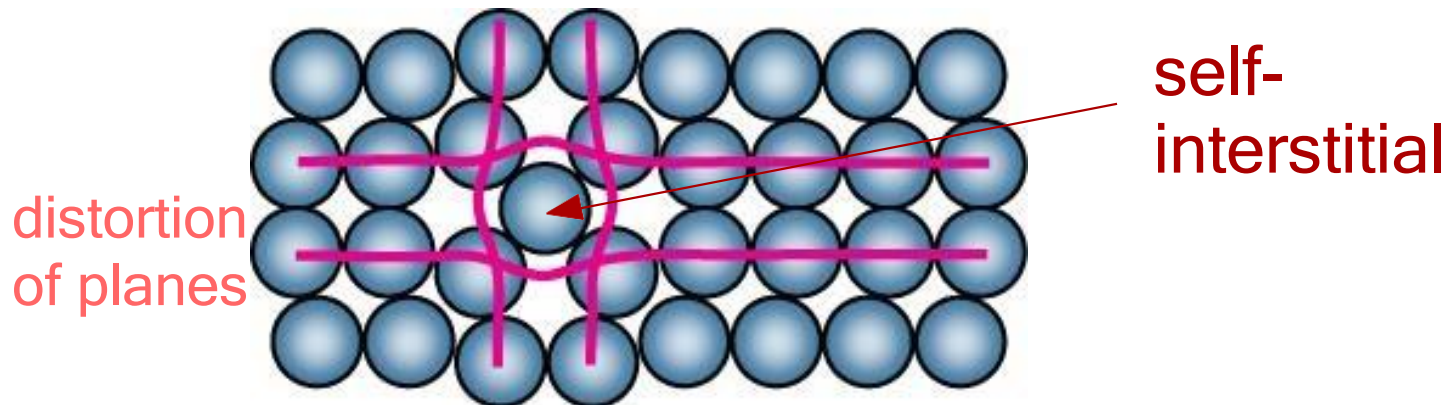

For Ionic Solids, Frenkel and Schottky defects are likely to form.

➤ *Schottky Defects*

When cation vacancy is associated with anion vacancy, the defect is called Schottky Defect.

➤ *Frenkel Defects*

When an atom leaves its regular site and occupy nearby interstitial site it gives rise to two defects i.e. one vacancy and other self interstitial these two defects are called as Frenkel Defects.

DEFECTS IN CERAMIC STRUCTURES

- Frenkel Defect
--a cation is out of place.
- Shottky Defect
--a paired set of cation and anion vacancies.

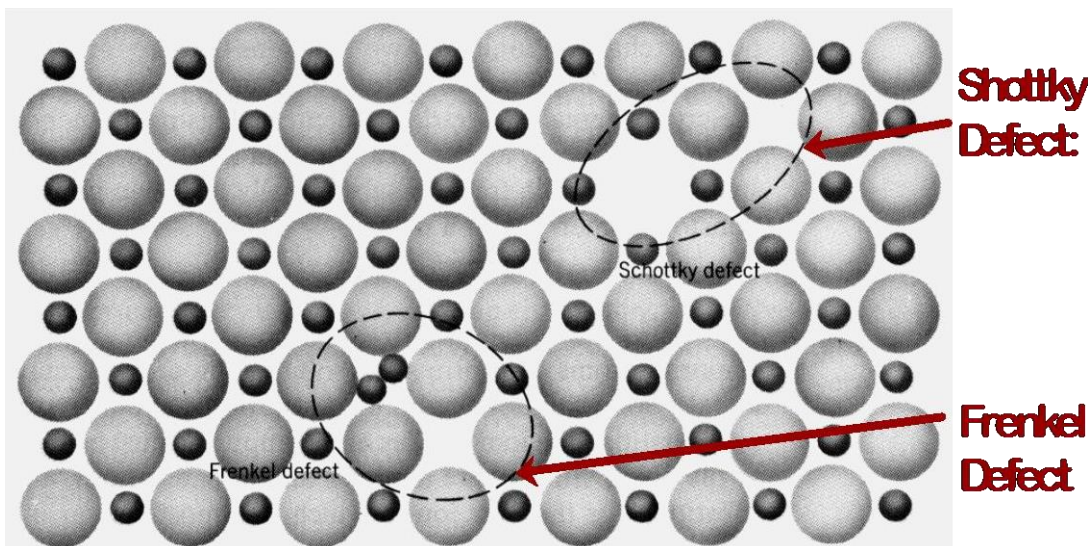

Adapted from Fig. 13.20, *Callister 5e*. (Fig. 13.20 is from W.G. Moffatt, G.W. Pearsall, and J. Wulff, *The Structure and Properties of Materials*, Vol. 1, *Structure*, John Wiley and Sons, Inc., p. 78.) See Fig. 12.21, *Callister 6e*.

$$\sim e^{-Q_D / kT}$$

- Equilibrium concentration of defects

2. Line Defects (*One dimensional*)

- A dislocation is a line discontinuity in the regular crystal structure.
- A part of the line will be missing from its regular site and this missing row is dislocation. The dislocation is centered along a line and hence the line defect is called dislocation.

The dislocation is a boundary between the slipped and unslipped region and lies in the slip plane

- The structure and behaviour of dislocations affect many of the properties of engineering materials.
- There are two basic types:

1) *Edge dislocations*

2) *Screw dislocations.*

1) Edge dislocation

- An *Edge dislocation* in a metal may be regarded as the insertion (or removal) of an extra half plane of atoms in the crystal structure.
- In Ionic and Covalent solids edge dislocations involve extra half planes of *unit cells*.
- If we consider a perfect crystal to be made up of vertical planes parallel to one another and to the side faces. If one of these vertical planes does not extend from the top to the bottom of crystals but ends part way within crystal, it is called as edge dislocation.

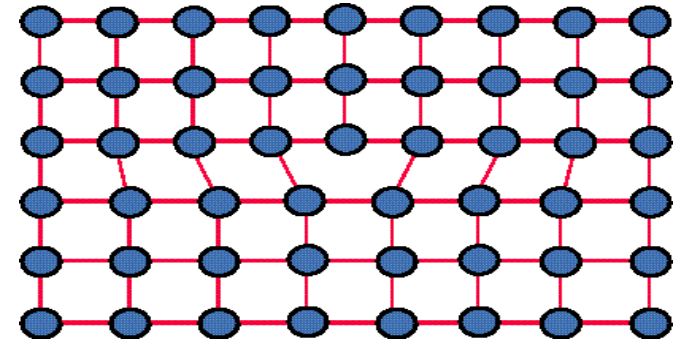

- Berger vector is perpendicular to dislocation line.

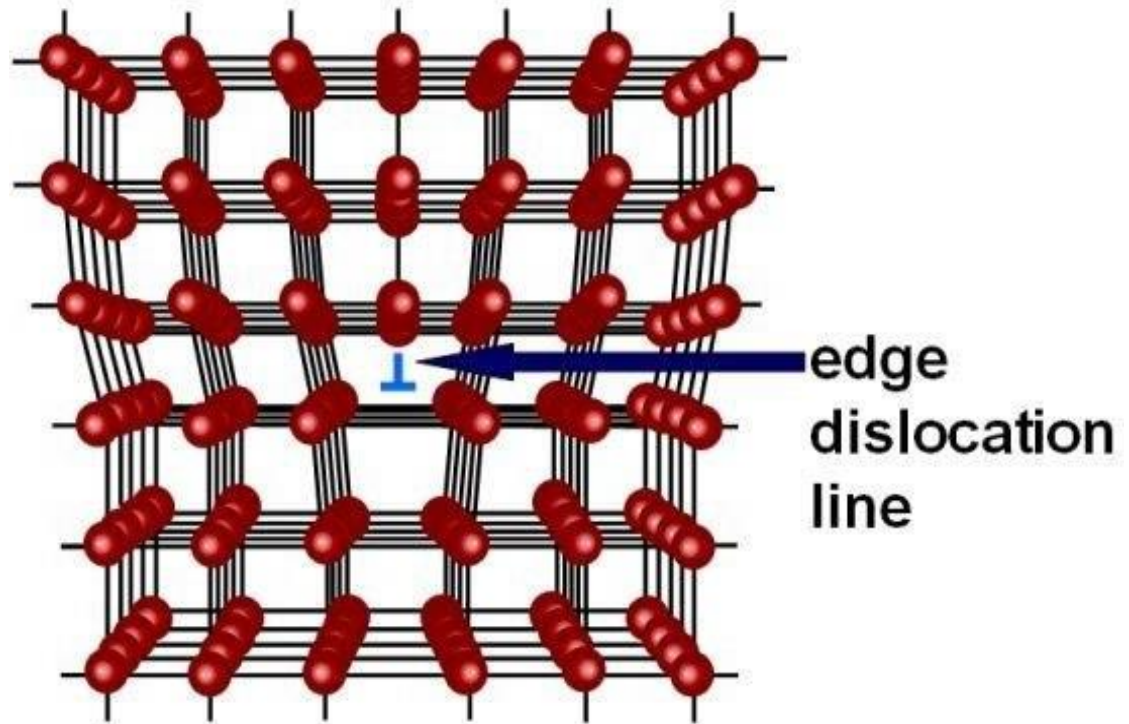

Movement of an Edge Dislocation

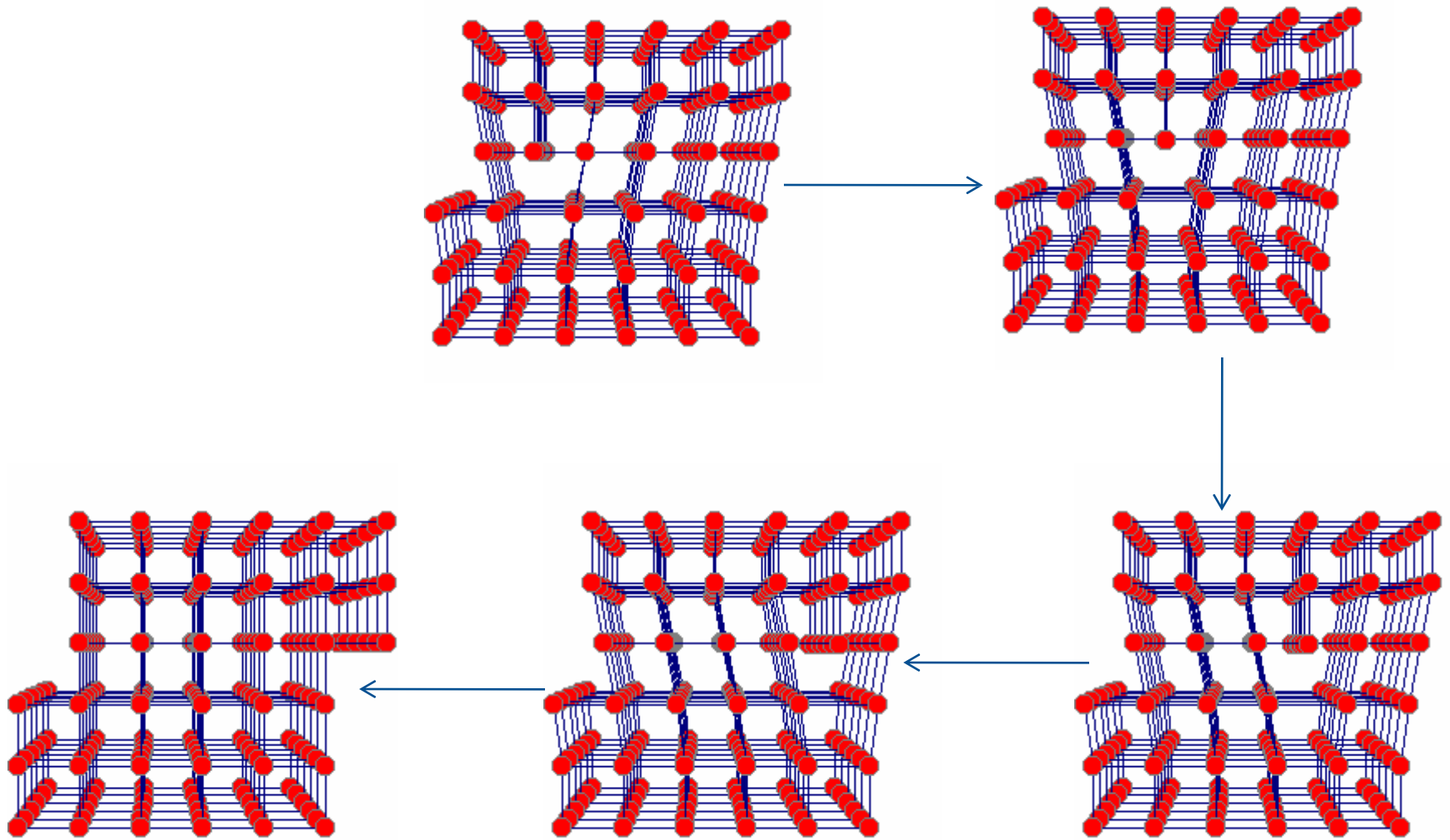

2) Screw dislocation

- In screw dislocation, there is transformation of successive atomic planes into the surface of helix around dislocation line due to shear stress i.e. it follows helical or screw path.
- A screw dislocation can be imagined as being produced by cutting the crystal partway through with a knife and then shearing one part of the crystal with respect to the other parallel to the cut.

- Berger vector is parallel to dislocation line.

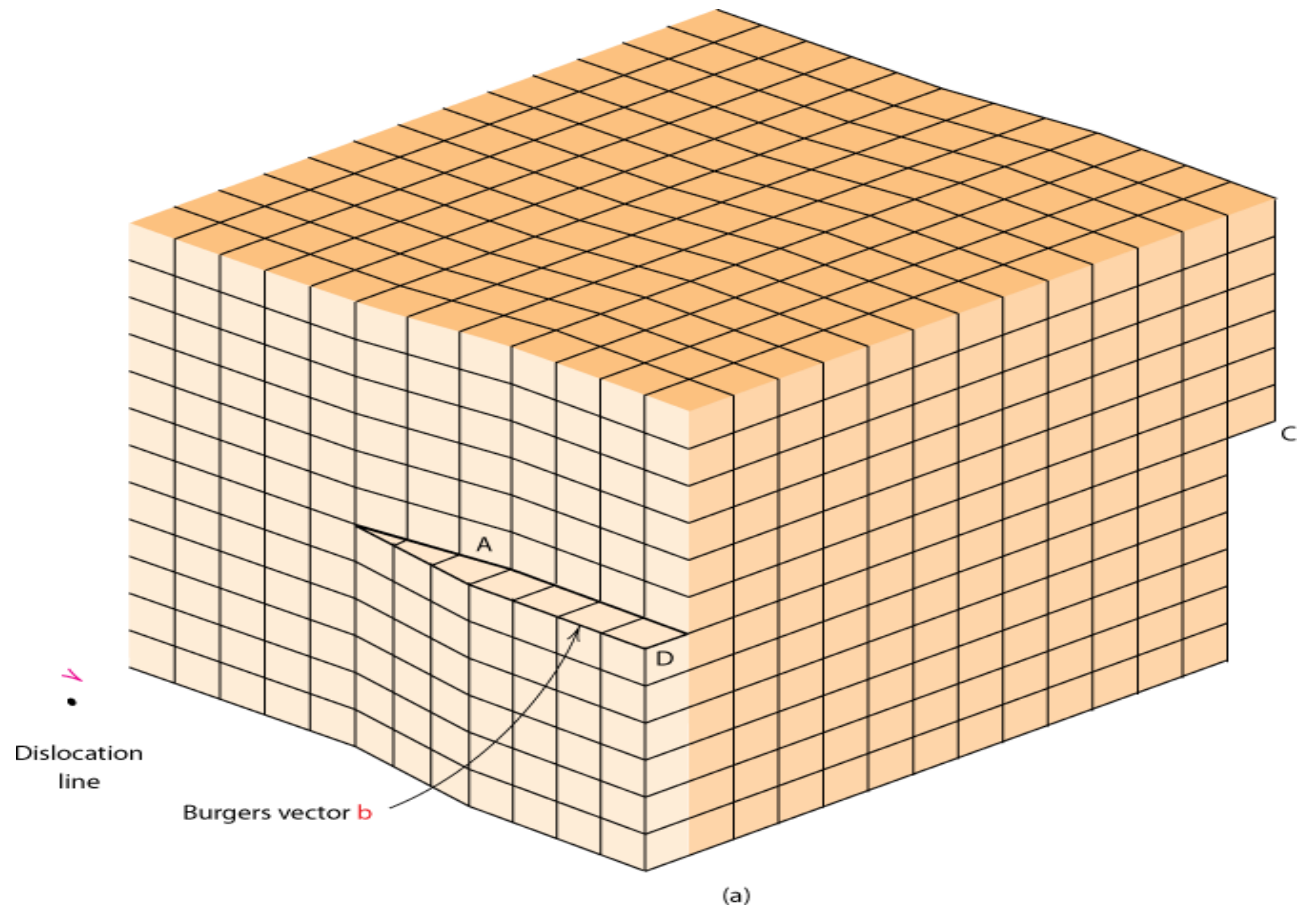

Linear/Line Defects - (Dislocations)

- Line imperfection or dislocation are defects that cause lattice distortions.

- Dislocation are created during:
 - Solidification
 - Permanent deformation of crystalline solid
 - Vacancy condensation
 - Atomic mismatch in solid solution

- Different types of line defects are:
 - Edge dislocation
 - Screw dislocation
 - Mixed dislocation



- An edge dislocation is created in a crystal by **insertion** of extra half planes of atoms. Edge Dislocation

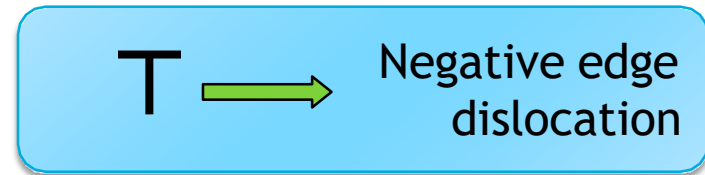

- In figure 4.18, a linear defect occurs in the region just above the inverted T, where an extra half plane of atoms has been wedged in.



Figure 4.18 : Positive edge dislocation in a crystalline lattice.

Screw Dislocation

- The screw dislocation can be formed in a perfect crystal by applying upward and downward **shear stresses** to regions of a perfect crystal that have been separated by a cutting plane as shown in Figure 4.20a.

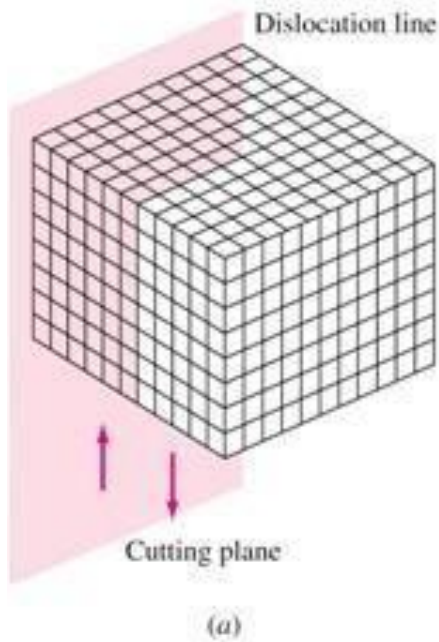
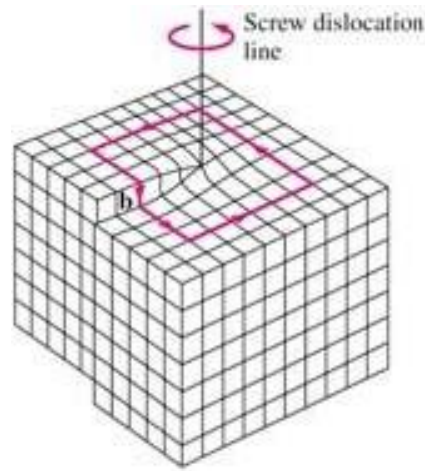

Figure 4.20a

Formation of a screw dislocation:

A perfect crystal is sliced by a cutting plane, and up and down shear stresses are applied parallel to the cutting plane to form the screw dislocation as in (b).

- These shear stresses introduce a region of distorted crystal lattice in the form of a spiral ramp of distorted atoms or screw dislocation as Figure 4.20b.



(b)

Figure 4.20b

Formation of a screw dislocation:

A screw dislocation is shown with its slip or Burgers vector \mathbf{b} parallel to the dislocation.

- The region of distorted crystal is not well defined and is at least several atoms in diameter.
- A region of shear strain is created around the screw dislocation in which energy stored.
- The slip or Burgers vector of the screw dislocation is *parallel* to the dislocation line as shown in Figure 4.20b.

- Most crystals have components of both edge and screw dislocation.
Mixed Dislocation

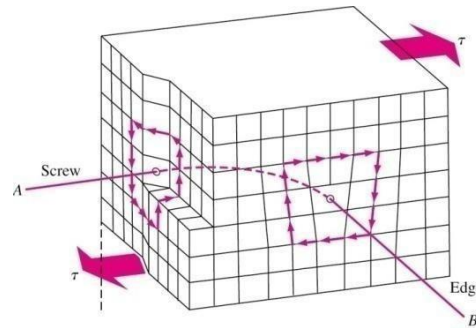

- Dislocation, since it has an irregular atomic arrangement, will appear as dark lines when observed in an electron microscope.

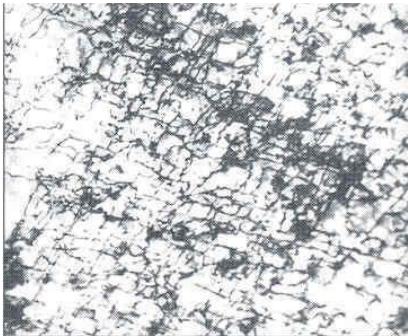

Dislocation structure of iron deformed 14% at -195°C

3. Planar or Surface defects

(Two dimensional)

- Planar defects arise due to change in the stacking of atomic planes during mechanical and thermal treatments. The change may be of the orientation or of the stacking sequence of the planes.

- Planar defects are of following types:
 - A. *Grain boundaries*
 - B. *Tilt boundaries*
 - C. *Twin boundaries*

A) Grain Boundaries

- A Grain Boundary is a general planar defect that separates regions of different crystalline orientation (i.e. *grains*) within a polycrystalline solid . Grain boundaries are usually the result of uneven growth when the solid is crystallizing.

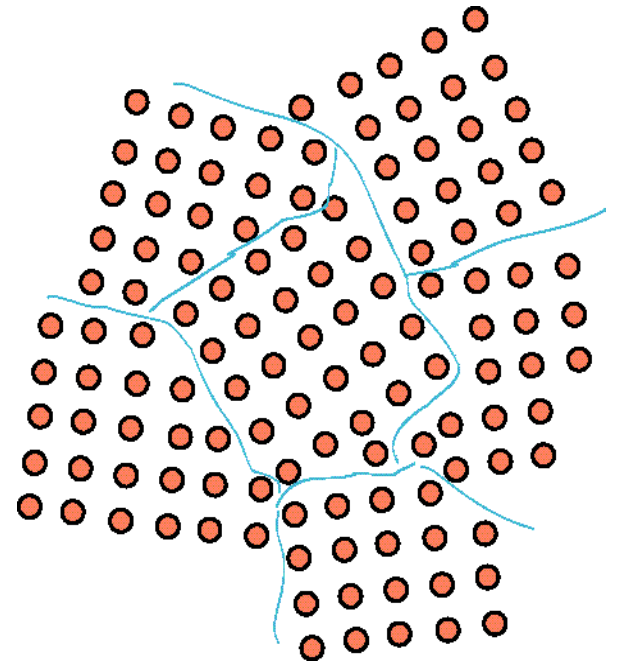

B) Tilt Boundaries

- When the angle between two crystals is less than 10° , the distortion is not so drastic as to be compared with a non crystalline material. They are also called low angle boundaries.
- It can be described as set of parallel, equally spaced edge dislocation of same sign located one above other.
- A Tilt Boundary, between two slightly mis-aligned grains appears as an array of edge dislocations.

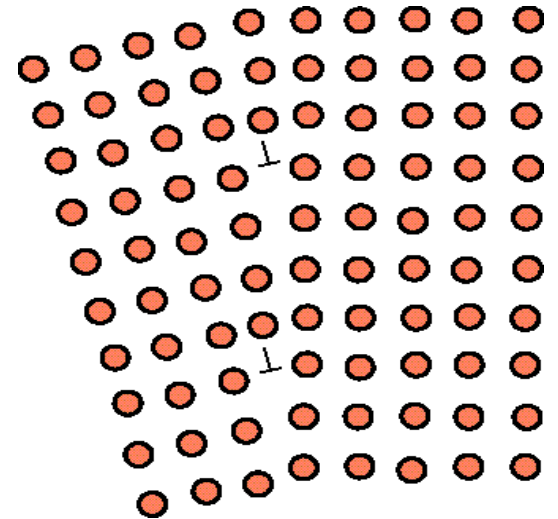

C) Twin Boundaries

- These are the boundaries in the grains at which the atomic arrangement on one side of the boundary is the mirror image of the atoms on the other side. The volume of material which has an orientation similar to the mirror image of the matrix orientation is called a twin.
- The plane is called twinning plane.

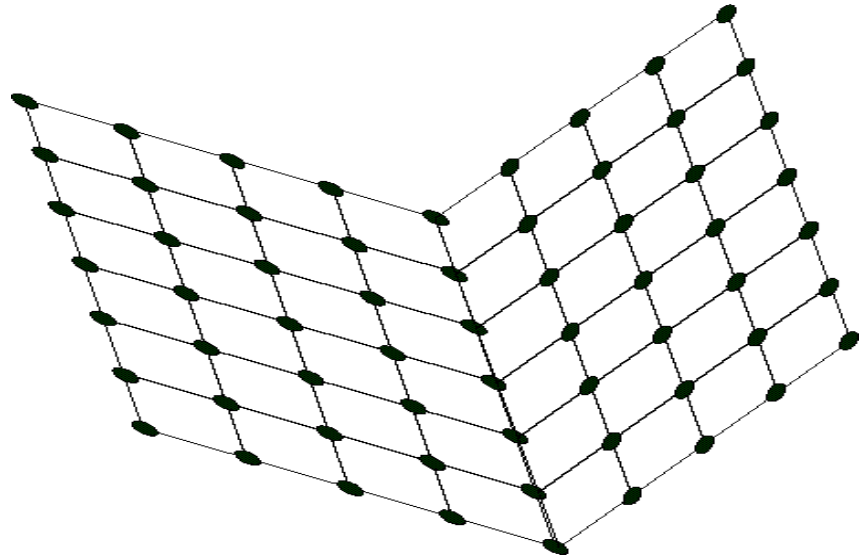

4. Volume Defects

- Volume defects such as stacking faults may arise when there is only small dissimilarity between the stacking sequence of close packed planes in FCC and HCP metals.
- Stacking faults are of two types called as intrinsic and extrinsic .Intrinsic fault results in one break whereas extrinsic fault results in two breaks in the sequence
- The volume defects may affect their mechanical, electrical and optical properties.

Solid Solutions

- Solid Solutions
- Substitutional Solid Solution
- Hume-Rothery Rules
- Interstitial Solid solution
- Intermediate Phases

- **Solid Solution or an Alloy is a phase, where two or more elements are completely soluble in each other.**
- **Solid solutions** have important commercial and industrial applications, as such mixtures often have superior properties to pure materials.
- Many metal alloys are solid solutions.
- *Ex: Cu-Ni, Au-Ag etc.*
- **In a solid solution, the metal in the major proportion is called the solvent (host or parent or matrix) and the metal in the minor proportion is called the solute**

- There are **two** types of Solid Solutions:
 - i. Substitutional Solid Solution
 - ii. Interstitial Solid Solution

Substitutional Solid Solution

▪ In this type of solid solution, the solute atoms substitute the atoms of solvent in the crystal structure of the solvent.

The substitutional solid solution are generally ordered at lower temperatures and at higher disordered temperatures.

▪ Temperature is the deciding factor.

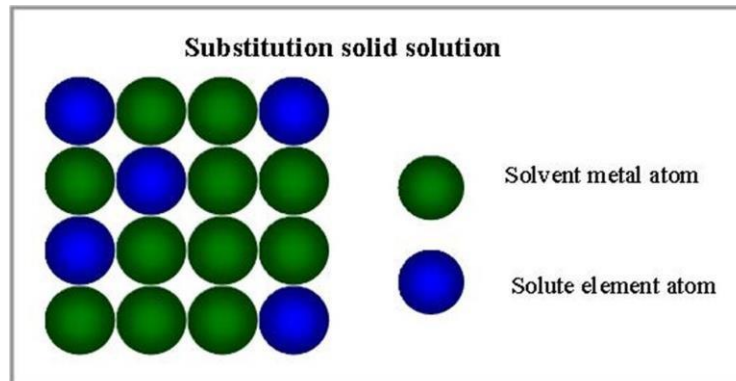

▪ There are **two** types of substitutional solid solutions:

- i. Ordered Substitutional Solid Solution (OSSS)
- ii. Disordered Substitutional Solid Solution (DSSS)

OSSS: In this type, the solute atoms substitute the solvent atoms in an orderly manner, taking up fixed positions of symmetry in lattice. This solid solution has uniform distribution of solute and solvent atoms.

DSSS: In this type, the solute atoms do not occupy any fixed positions but are distributed at random in the lattice structure of solvent. The concentration of solute atoms vary considerably through out lattice structure.

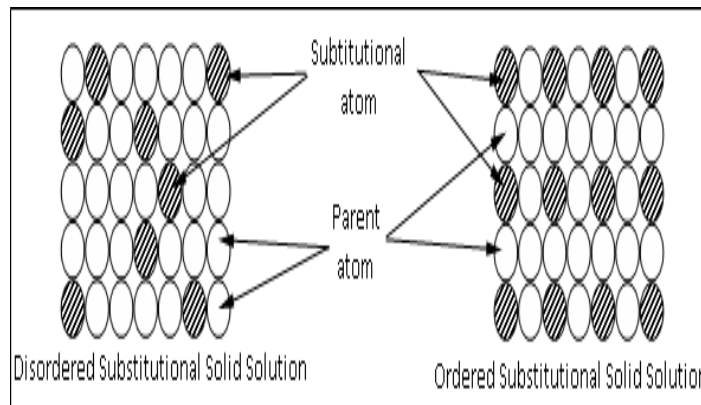

Ordered & Disordered substitutional solid solution

RULES FOR FORMATION OF SOLID SOLUTION

HUME-ROTHARY RULES:

- These are the rules which govern the formation of Solid Solutions.
- In other words, only when these rules are satisfied, a substitutional solid solution is formed.

1. Crystal Structure Factor:

- For complete solubility of two elements, they should have the same type of crystal lattice.
- For example, Au-Ag solution, both should have FCC structure.

2. Relative Size Factor:

- The atoms of the solute and solvent should have the same atomic size approximately.
- This factor is satisfied if the difference of atomic radii of two elements is less than 15%.

3. Electro-negativity:

- Higher the electro-negativity, greater is the chance of forming an intermediate phase rather than a solid solution.
- Electro-negativity is the tendency to acquire electrons.

4. Relative Valence Factor:

- Among two metals, which have satisfied all the above rules, the metal with lower valency tends to dissolve more of a metal of higher valency and vice-versa.

Interstitial Solid Solution

- These are formed when atoms of small atomic radii fit into the interstitial spaces of larger solvent atoms.
- Atoms of elements such as carbon, nitrogen, boron, hydrogen, etc. which have radii less than 1 \AA are likely to form interstitial solute atoms and may dissolve more readily in transition metals such as Fe, Ni, Mn, Cr, etc. than in other metals.

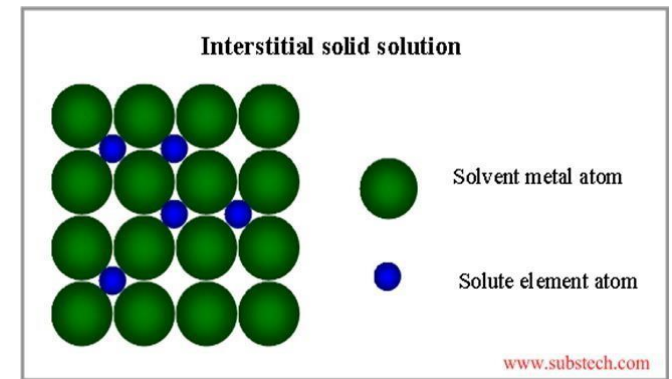

Intermediate Phases

- Intermediate phases are those phases whose chemical compositions are intermediate between the two pure metals and generally have crystal structure different from those of the base (parent) metals.
- An alloy can be made up of a solid solution phase entirely or can exist along with an intermediate phase.
- **An intermediate phase here is nothing but a compound and is made up of two or more elements of which at least one of them is a metal.**

- A compound is a chemical combination of positive and negative valence elements. i.e., atoms of different elements are combined in different proportions and are expressed by chemical formulae like H₂O, NaCl, etc.
- When a compound or intermediate phase is formed, the elements lose their individual identity and properties to a good extent and the compound will have its own characteristic physical, mechanical and chemical properties.

- There are **three** most common intermediate alloy phases:
 - i. Intermetallic or Valency Compounds
 - ii. Interstitial Compounds
 - iii. Electron Compounds

Intermetallic or Valence Compounds

- When alloy phase are exclusively metal-metal systems, they are called intermetallic compounds.
- These are formed between chemically dissimilar metals and are combined by following the rules of chemical valence.
- The combination is usually non-metallic and show poor ductility and poor electrical conductivity and have complex crystal structure.
- Examples for intermetallic compounds: $Mg_2Pb, Mg_2Sn, CaSe, Cu_2Se$

Interstitial Compounds

- These are similar to interstitial solid solutions except that they have more or less a fixed composition.
- Example: Fe_3C .
- The interstitial compounds are metallic in nature, have high melting points and are extremely hard.

Electron Compounds

- These are of variable compositions and do not obey the valence law, but have a definite electron to atom ratio.

Example: Cu_9Al_4

- Each Cu atom has 1 valence electron and each Al atom has 3 valence electrons.
- So 13 atoms which make up the compound have 21 valence electrons with electron to atom ratio being 21:13
- Electron compounds have properties same as those of solid solutions - wide range of compositions, high ductility and low hardness.

DEFINITION OF PHASE

Phase is Homogenous, physically distinct and mechanically separable part of the system

Phase diagram for pure substance

Pure substance- It is a substance constant Chemical composition through its mass . it may exist in one phase or more than one phase

If you look at the diagram, you will see that there are three lines, three areas marked "solid", "liquid" and "Vapour", and two special points marked "C" and "T".

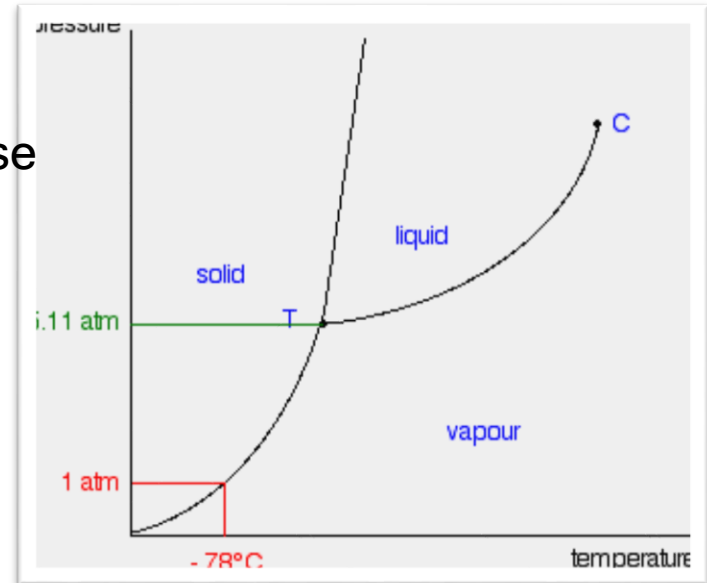

Three areas

At point 1 in the diagram, the substance would be a solid because it falls into that area of the phase diagram. At 2, it would be a liquid; and at 3, it would be a Vapour (a gas)

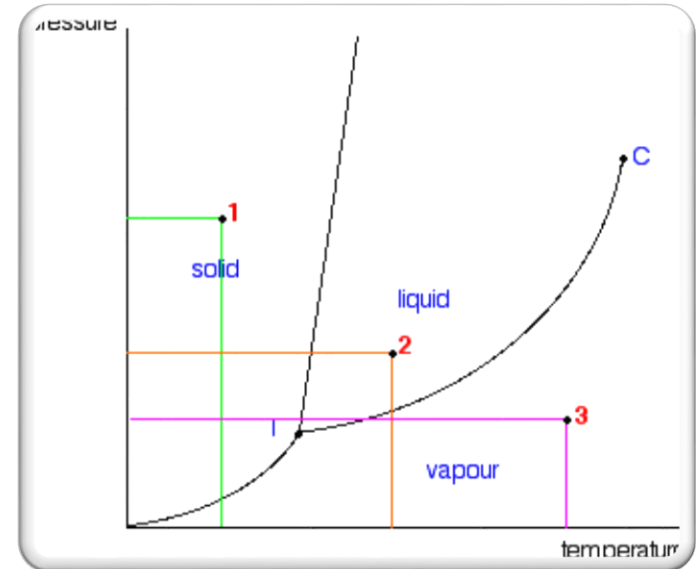

Moving from solid to liquid by changing the temperature:

(fusion line)

If increases the temperature while keeping the pressure constant - as shown in the figure. As the temperature increases to the point where it crosses the line, the solid will turn to liquid

(solid melts at higher temperature)

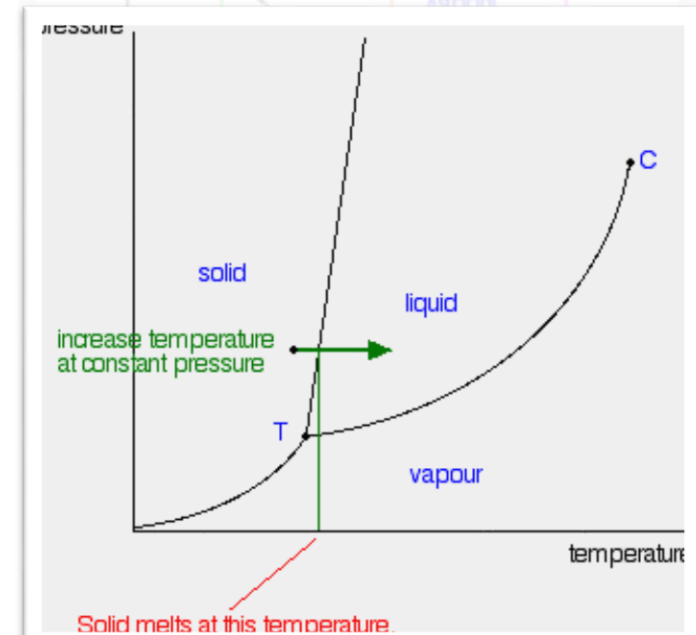

Moving from solid to liquid by changing the pressure:

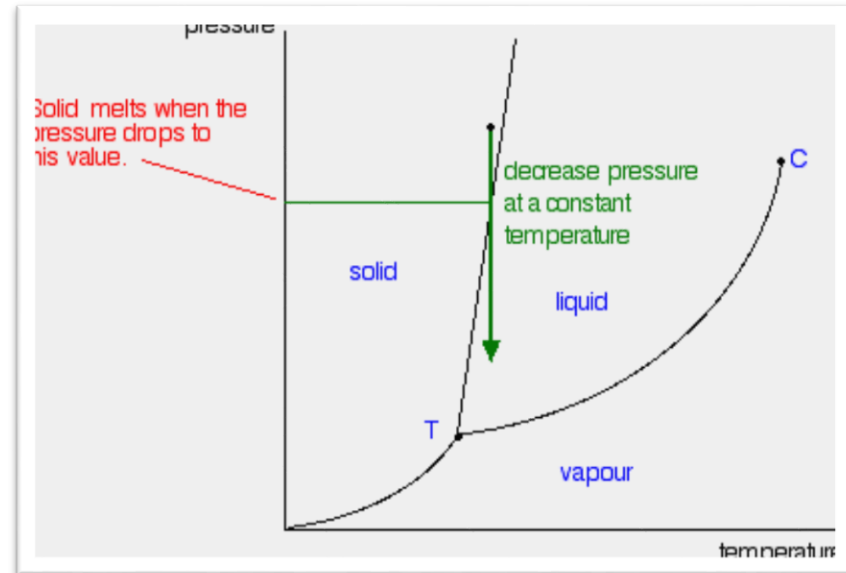

Moving from liquid to Vapour:

(Vapourisation line)

The liquid will change to a Vapour - it boils - when it crosses the boundary line between the two areas

As the pressure increases, so the boiling point increases.

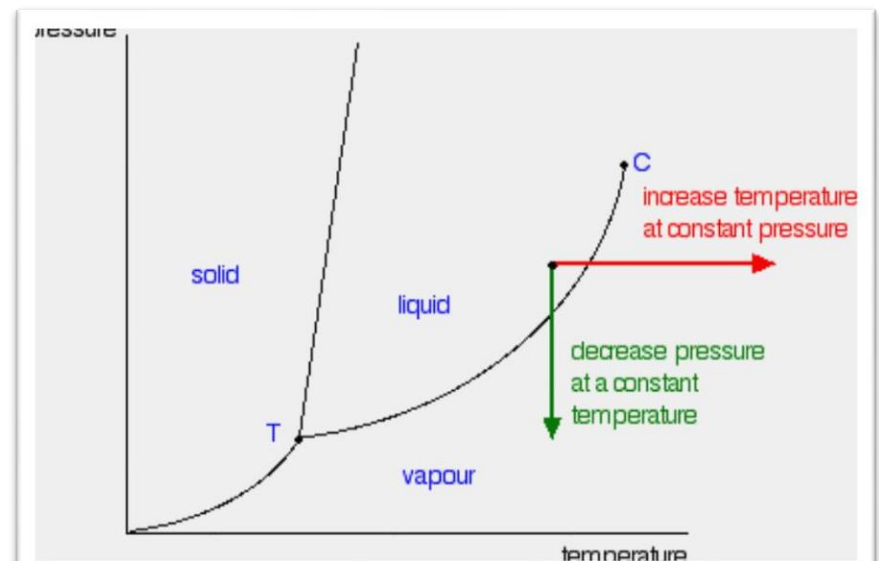

Critical point

In liquid-vapour equilibrium curve has a top limit at that point C in the phase diagram. It is called critical point. The temperature and pressure corresponding to this are known as the critical temperature and critical pressure.

If you increase the pressure on a gas (Vapour) at a temperature lower than the critical temperature, you will eventually cross the liquid-Vapour equilibrium line and the Vapour will condense to give a liquid

Shortcut Def

the intersection of saturated liquid line and saturated Vapour line

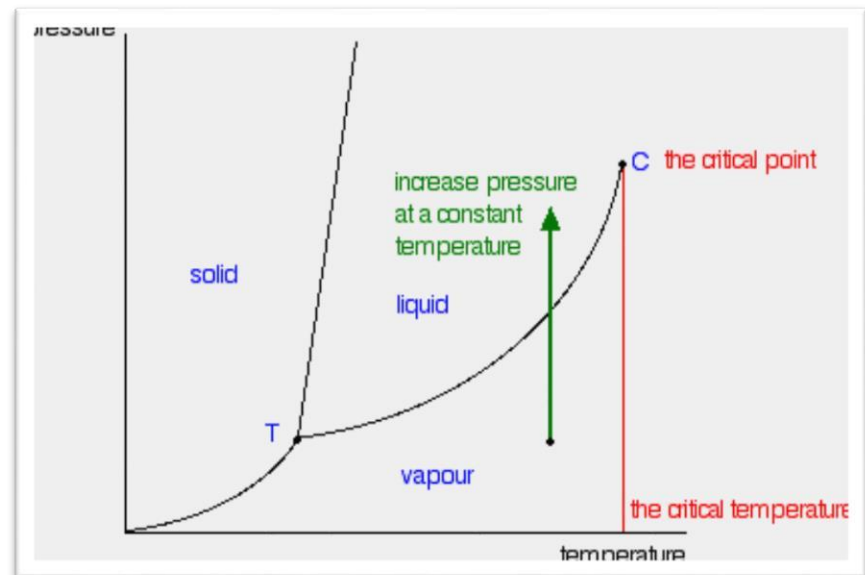

Moving from solid to Vapour (sublimation line)

If the temperature and pressure fell exactly on same line, there would be solid and Vapour in equilibrium with each other - the solid would be subliming. (Sublimation is the change directly from solid to Vapour or vice versa without going through the liquid phase.)

The triple point

At point T on the diagram is called the triple point.

The combination of temperature and pressure where all three phases are in equilibrium together. That's why it is called a triple point.

Def-

The intersection of fusion line, Vapourisation line and sublimation line is called triple point

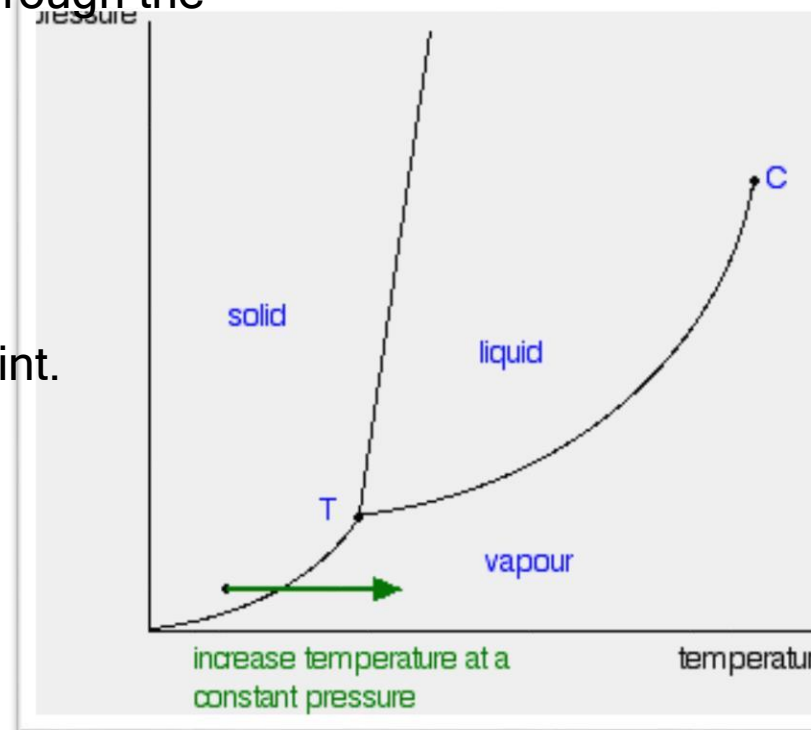

2-D Representation of phase diagram

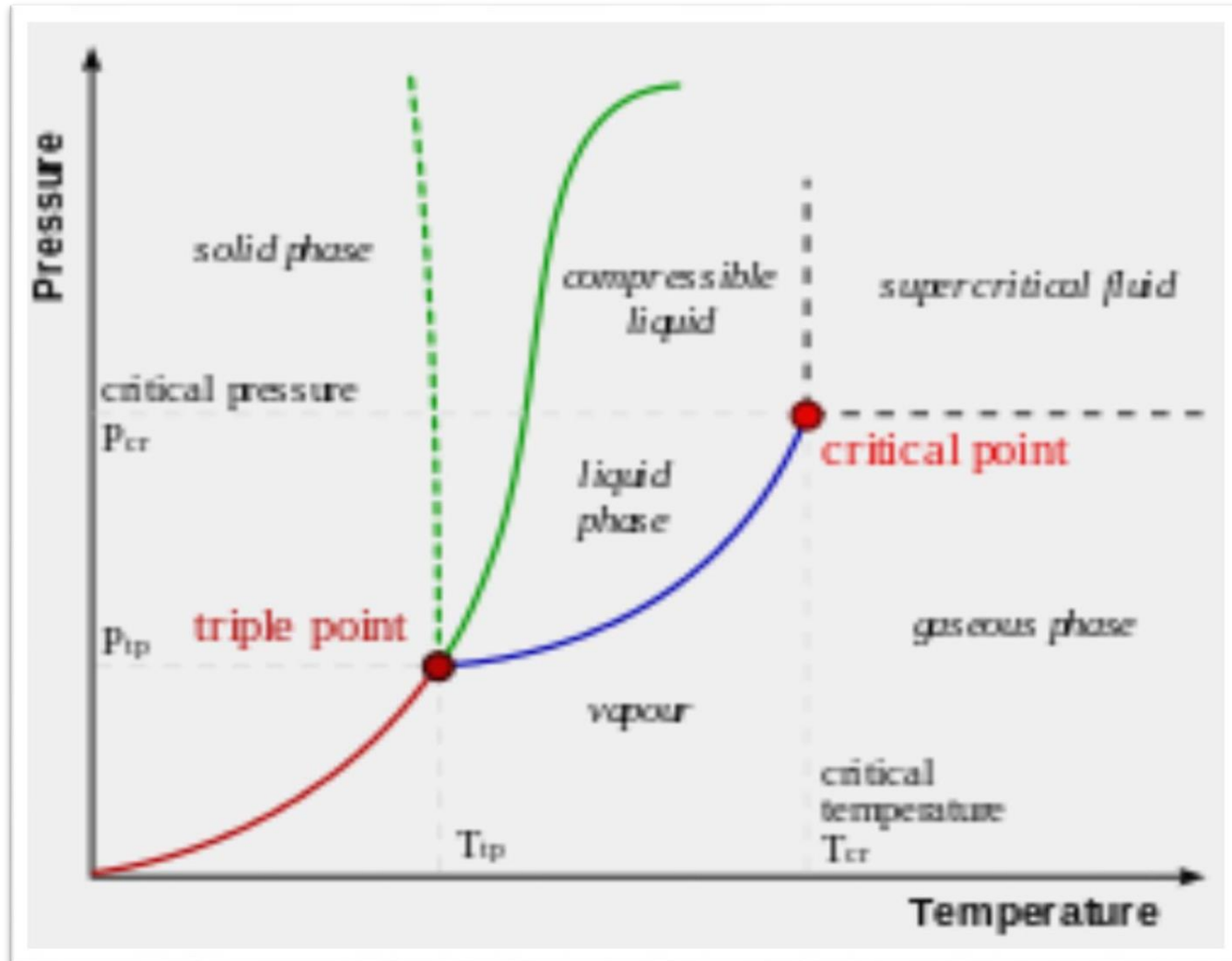

Phase Diagrams of Water and Carbon Dioxide

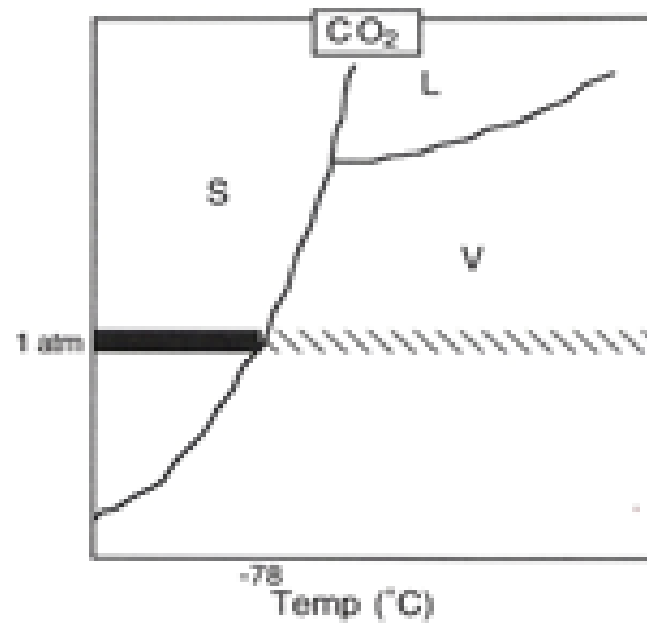
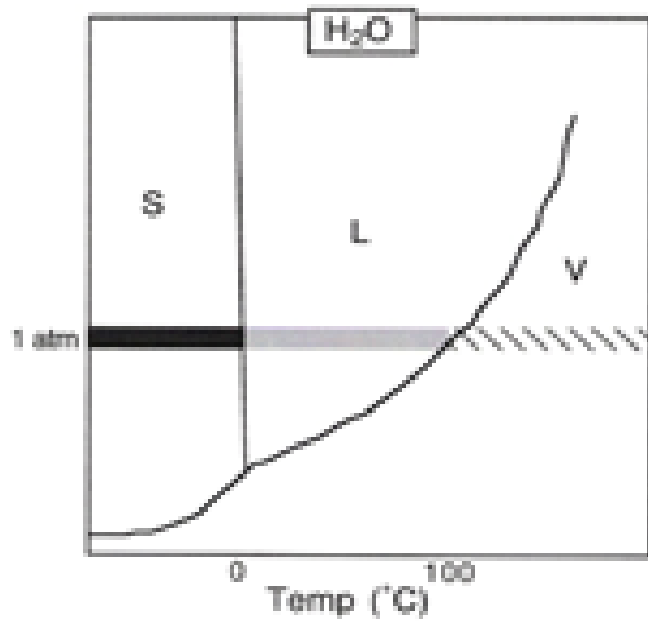

Types of phase diagrams

1) ISOMORPHOUS SYSTEMS

2) EUTECTIC SYSTEMS

1) ISOMORPHOUS SYSTEMS

THESE diagrams are loop type and are obtained for two metals
Having complete solubility in the liquid state as well as solid state

Ex - cu/Ni, au/ag

Examples

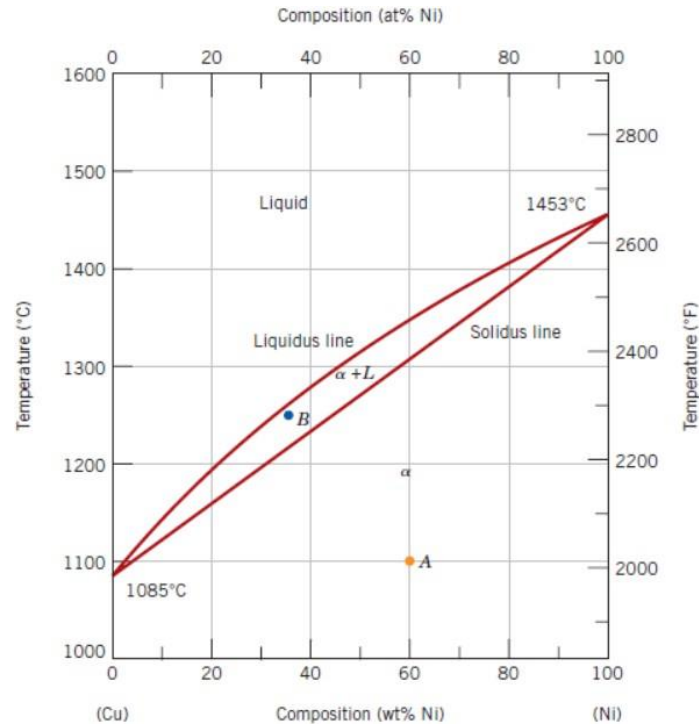

Cu-Ni phase diagram
Temperature- Composition
Binary isomorphous diagram

Lever rule

- Used to find the composition of phases.

- $$W_s = \frac{W_o - W_l}{W_s - W_l}$$
- $$W_l = \frac{W_s - W_o}{W_s - W_l}$$

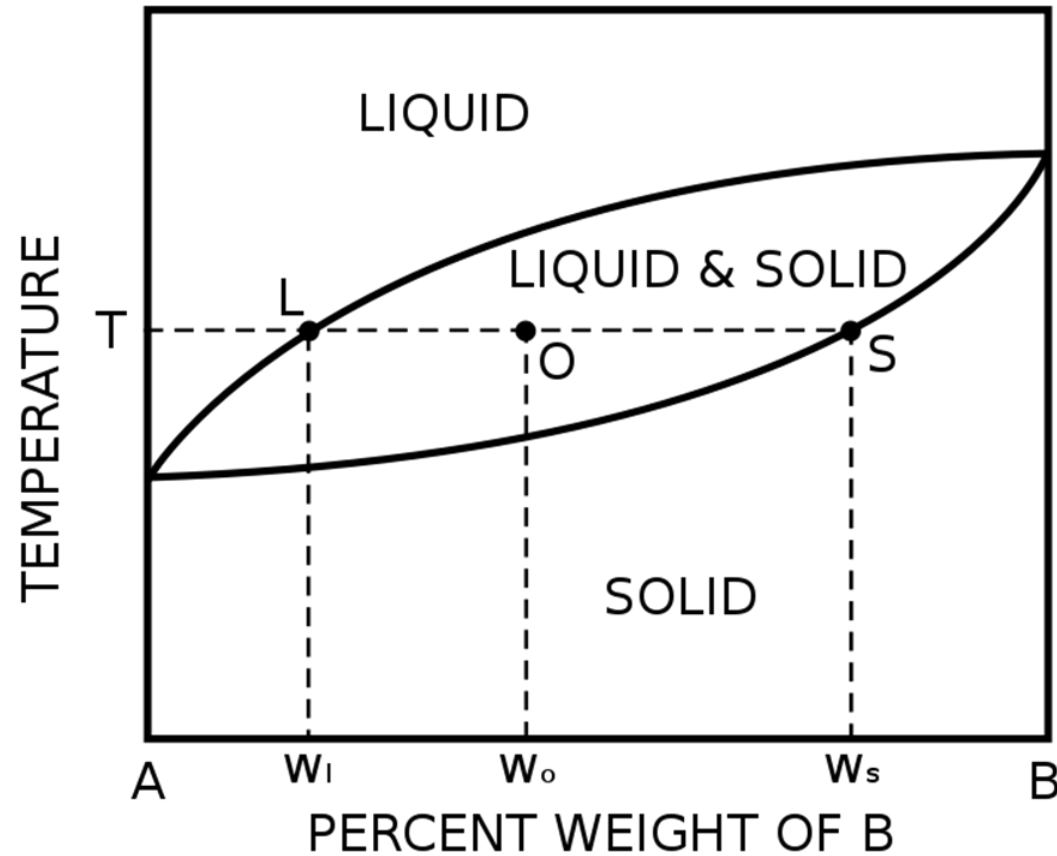

Binary phase diagram

On a two component or binary diagram three variables can be represented. These are generally pressure (P), temperature (T) and compositional changes (X)

To graphically represent a Binary diagram one variable must be kept constant, which is usually P, and the phase diagram is plotted as a T-X diagram for a specific Pressure. Ex- isomorphous systems

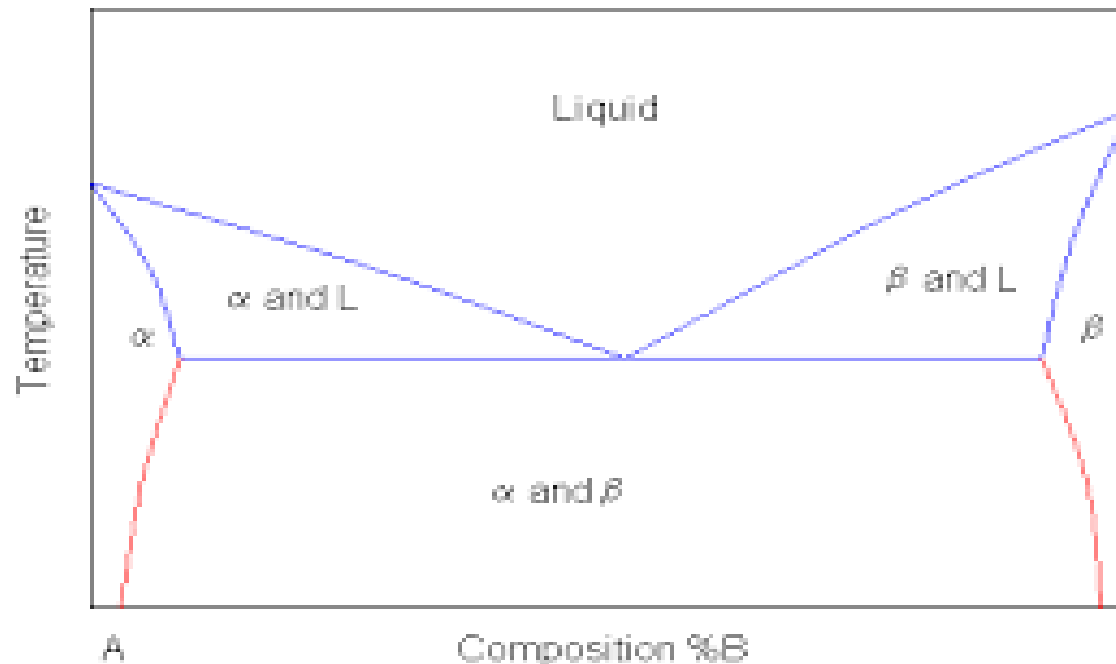

Eutectic systems –

These diagrams are obtained for having complete solubility in the liquid state and complete insolubility in the solid state

Ex- Pb/As ,bi-cd, th -ti

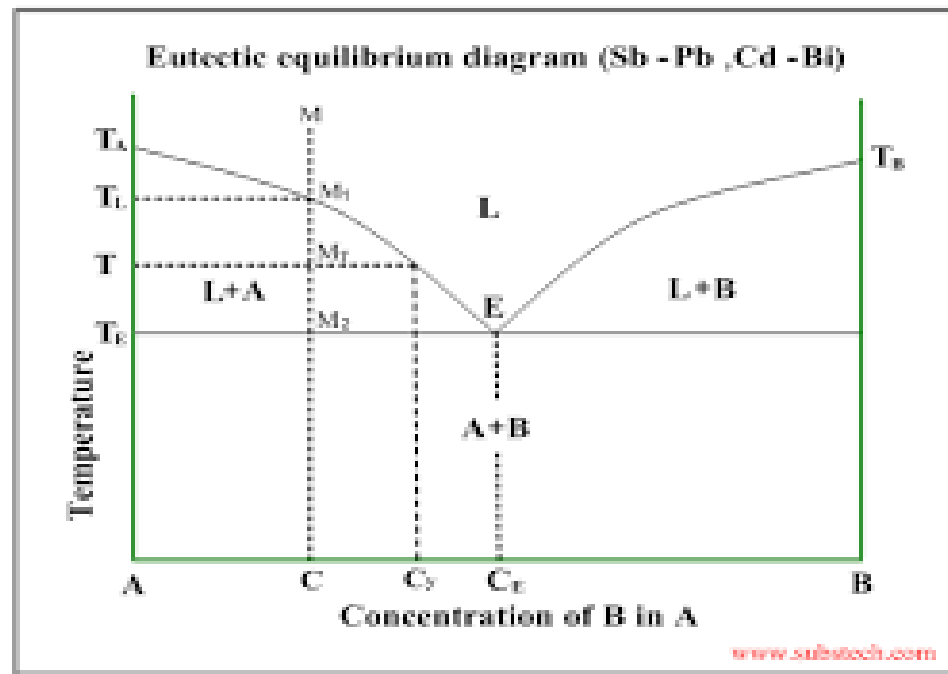

The Iron-Iron Carbide Diagram

- A map of the temperature at which different phase changes occur on very slow heating and cooling in relation to Carbon, is called Iron- Carbon Diagram.
- Iron- Carbon diagram shows
 - the type of alloys formed under very slow cooling,
 - proper heat-treatment temperature and
 - how the properties of steels and cast irons can be radically changed by heat-treatment.

Cooling curve for pure iron

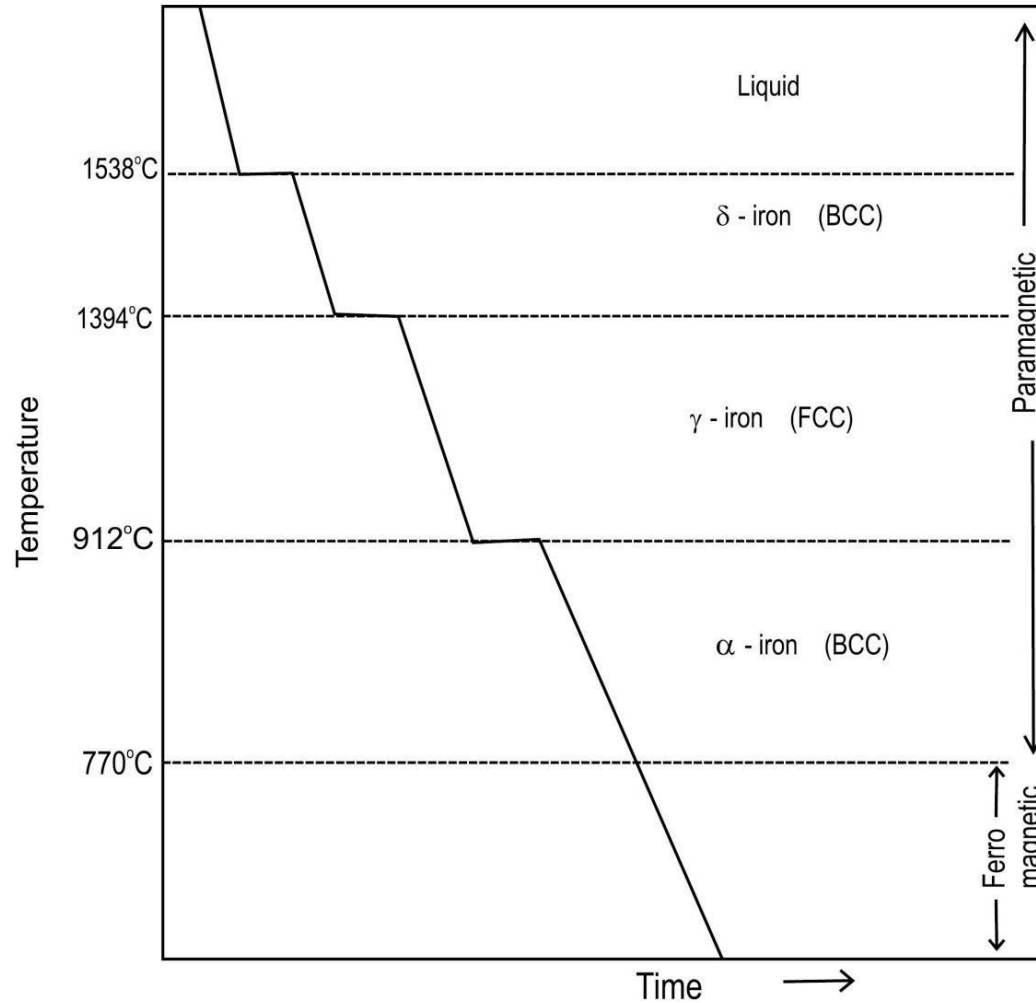

IRON-CARBON (Fe-C) PHASE DIAGRAM

Pure iron: 3 solid phases
 BCC ferrite (α)
 FCC Austenite (γ)
 BCC δ
 Beyond 6.7% C
 cementite (Fe_3C)
 Eutectic: 4.3% C
 $L - \gamma + \text{Fe}_3\text{C}$
 (L - solid + solid)
 Eutectoid: 0.76% C
 $\gamma + \alpha + \text{Fe}_3\text{C}$
 (solid - solid + solid)

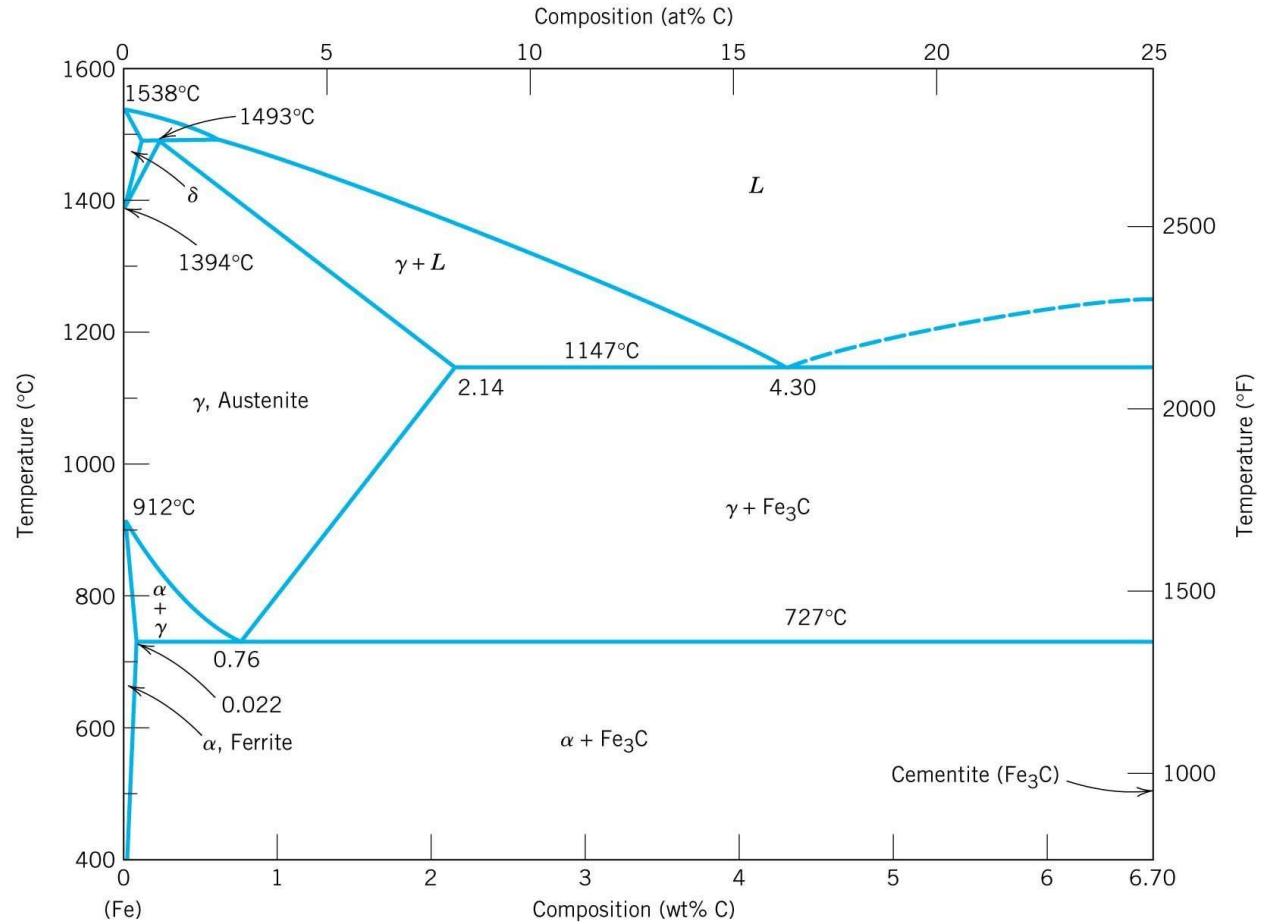
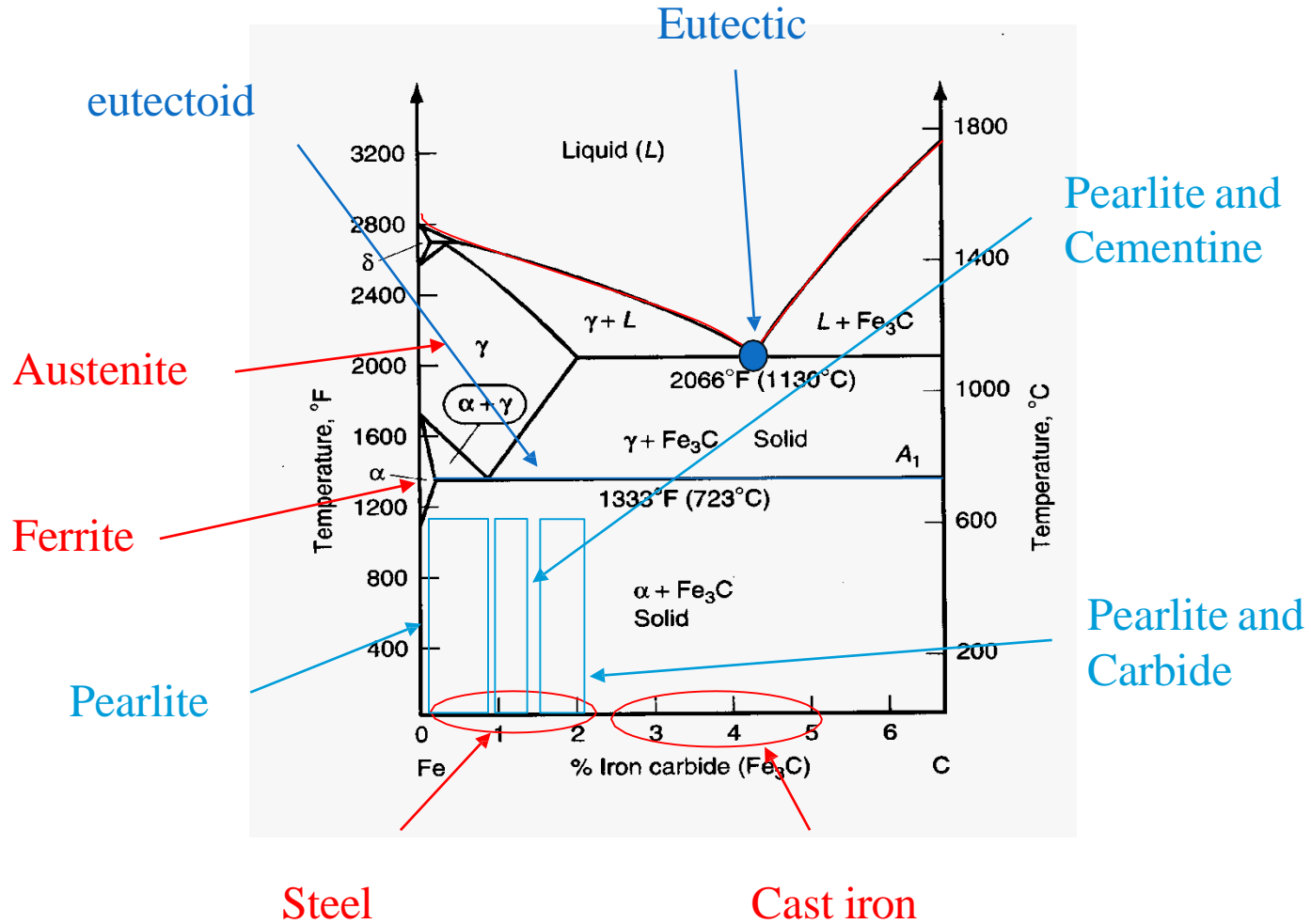

FIGURE 9.21 The iron-iron carbide phase diagram. [Adapted from *Binary Alloy Phase Diagrams*, 2nd edition, Vol. 1, T. B. Massalski (Editor-in-Chief), 1990. Reprinted by permission of ASM International, Materials Park, OH.]

How to read the Fe-C phase diagram



Definition of structures

Various phases that appear on the Iron-Carbon equilibrium phase diagram are as under:

- Ferrite
- Pearlite
- Austenite
- Cementite
- Ledeburite
- Martensite

Definition of structures

- **Ferrite** is known as α solid solution.
- It is an interstitial solid solution of a small amount of carbon dissolved in α (BCC) iron.
- stable form of iron below 912 deg.C
- The maximum solubility is 0.025 % C at 723°C and it dissolves only 0.008 % C at room temperature.
- It is the softest structure that appears on the diagram.

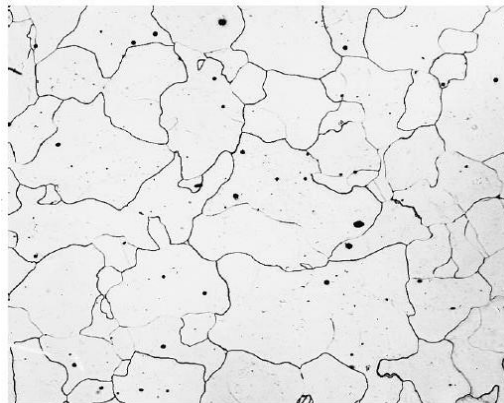

Definition of structures

- **Pearlite** is the eutectoid mixture containing 0.80 % C and is formed at 723°C on very slow cooling.
- It is a very fine platelike or lamellar mixture of ferrite and cementite.
- The white ferritic background or matrix contains thin plates of cementite (dark).

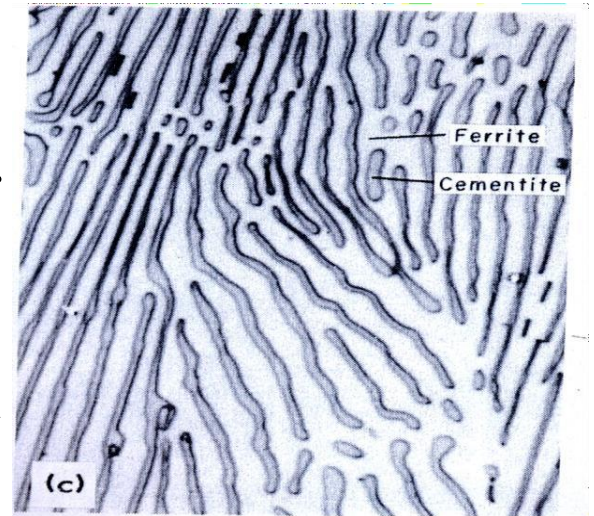

Definition of structures

- **Austenite** is an interstitial solid solution of Carbon dissolved in γ (F.C.C.) iron.
- Maximum solubility is 2.0 % C at 1130°C.
- High formability, most of heat treatments begin with this single phase.
- It is normally not stable at room temperature. But, under certain conditions it is possible to obtain austenite at room temperature.

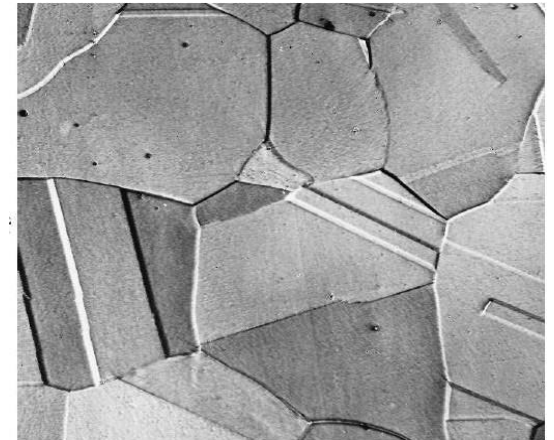

Definition of structures

- **Cementite** or iron carbide, is very hard, brittle intermetallic compound of iron & carbon, as Fe_3C , contains 6.67 % C.
- It is the hardest structure that appears on the diagram, exact melting point unknown.
- Its crystal structure is orthorhombic.
- It is has
 - low tensile strength (approx. 5,000 psi), but
 - high compressive strength.

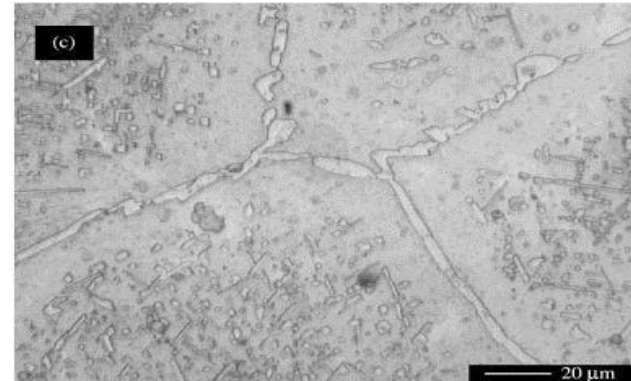

Definition of structures

- **Ledeburite** is the eutectic mixture of austenite and cementite.
- It contains 4.3 percent C and is formed at 1130°C.

Definition of structures

⑩ **Martensite** - a super-saturated solid solution of carbon in ferrite.

⑩ It is formed when steel is cooled so rapidly that the change from austenite to pearlite is suppressed.

⑩ The interstitial carbon atoms distort the BCC ferrite into a BC-tetragonal structure (BCT).; responsible for the hardness of quenched steel

Microstructure of different phases of steel

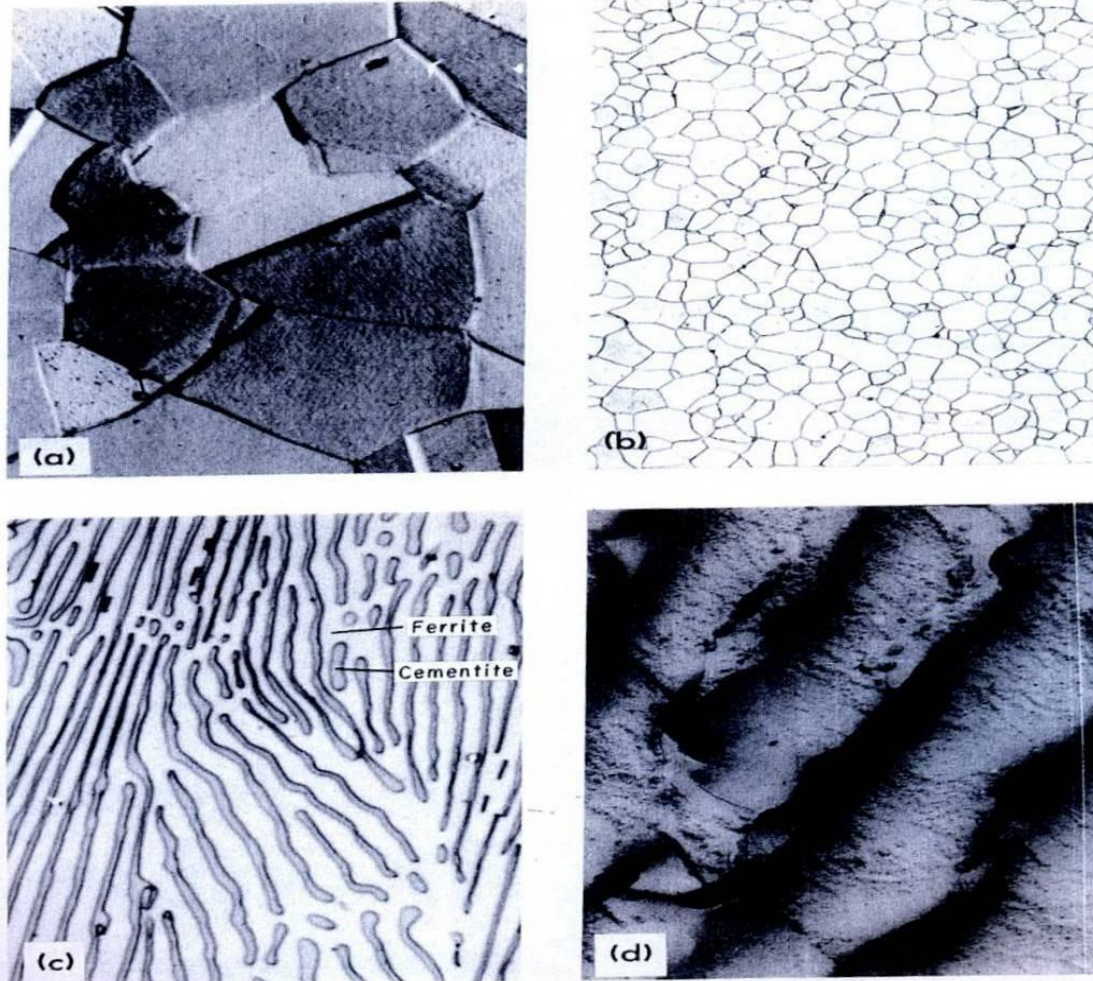
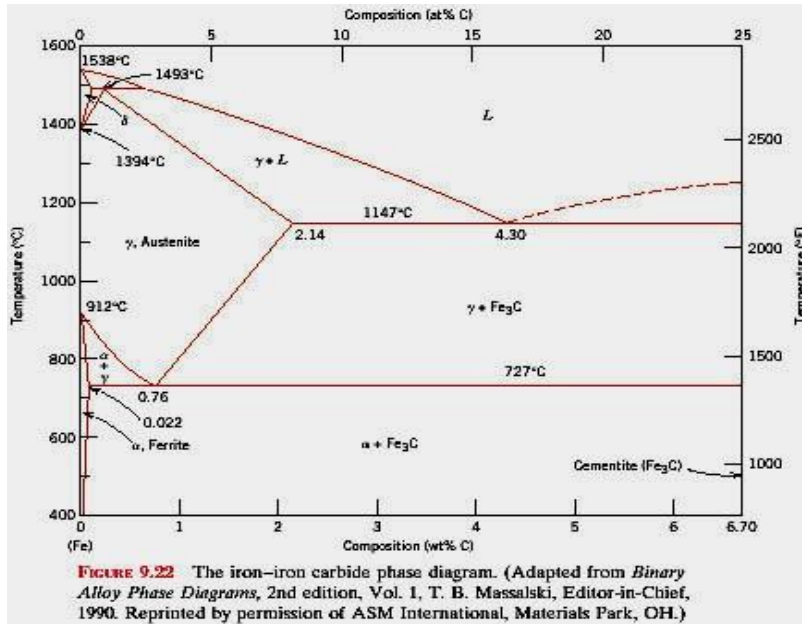

Fig. 7-8 The microstructure of (a) austenite, 500X; (b) ferrite, 100X; (c) pearlite, 2,500X; (d) pearlite, electron micrograph, 17,000X; enlarged 3X in printing. (a, b, and c, Research Laboratory, U.S. Steel Corporation.)

Various Features of Fe-C diagram



Phases present

- Liquid(l)
- δ : BCC structure, Paramagnetic
- α ferrite: BCC structure, Ferromagnetic, Fairly ductile
- γ austenite: FCC structure, Non-magnetic, Ductile
- Fe_3C cementite: Orthorhombic, Hard, brittle

Reactions

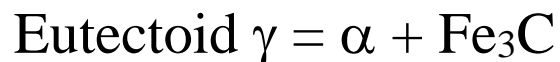
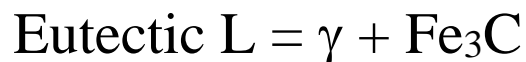

Max. solubility of C in ferrite=0.022%

Max. solubility of C in austenite=2.11%

Three Phase Reactions

A horizontal line always indicates an invariant reaction in binary phase diagrams

- Peritectic reaction at 1495°C and 0.18% C,
 - δ -ferrite + $L \leftrightarrow \gamma$ -iron (austenite)
 - (almost no engineering importance).
- Eutectic reaction at 1147°C and 4.3 % C,
 - $L \leftrightarrow \gamma$ -iron + Fe₃C (cementite) [ledeburite]
 - alloys called **cast irons**
- Eutectoid reaction at 727°C and 0.77% C,
 - γ -iron $\leftrightarrow \alpha$ -ferrite + Fe₃C (cementite) [pearlite]
 - They are **steels**

The Iron-Iron Carbide Diagram

The diagram shows **three horizontal lines** which indicate isothermal reactions (on cooling / heating):

- First horizontal line is **at 1490°C**, where peritectic reaction takes place:



- Second horizontal line is **at 1130°C**, where eutectic reaction takes place:



- Third horizontal line is **at 723°C**, where eutectoid reaction takes place:



Cast Irons

- Iron-Carbon alloys of 2.11% C or more are cast irons.
- Typical composition: 2.0-4.0% C, 0.5-3.0% Si, less than 1.0% Mn and less than 0.2% S.
- Si substitutes partially for C and promotes formation of graphite as the carbon rich component instead Fe₃C.

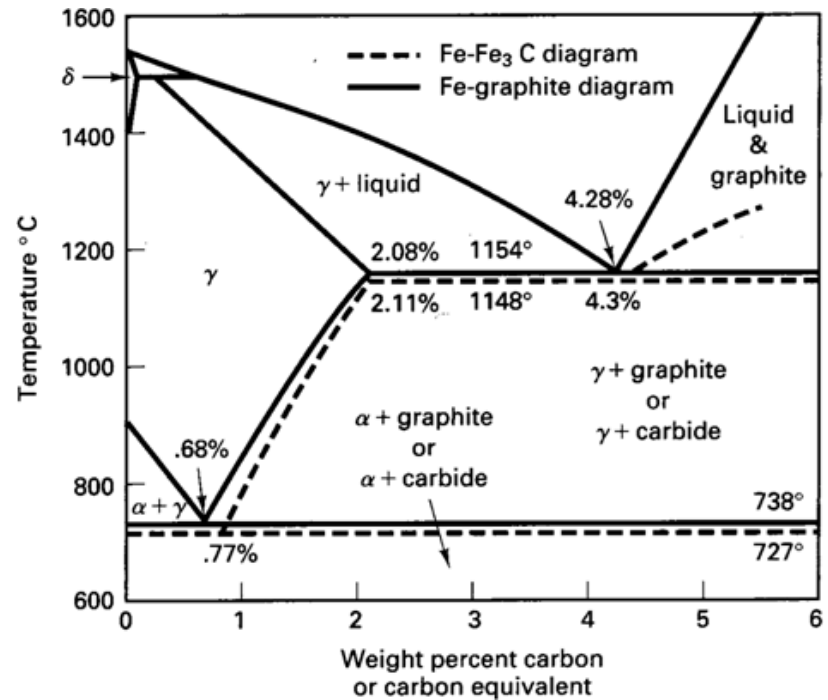

The Austenite to ferrite / cementite transformation in relation to Fe-C diagram

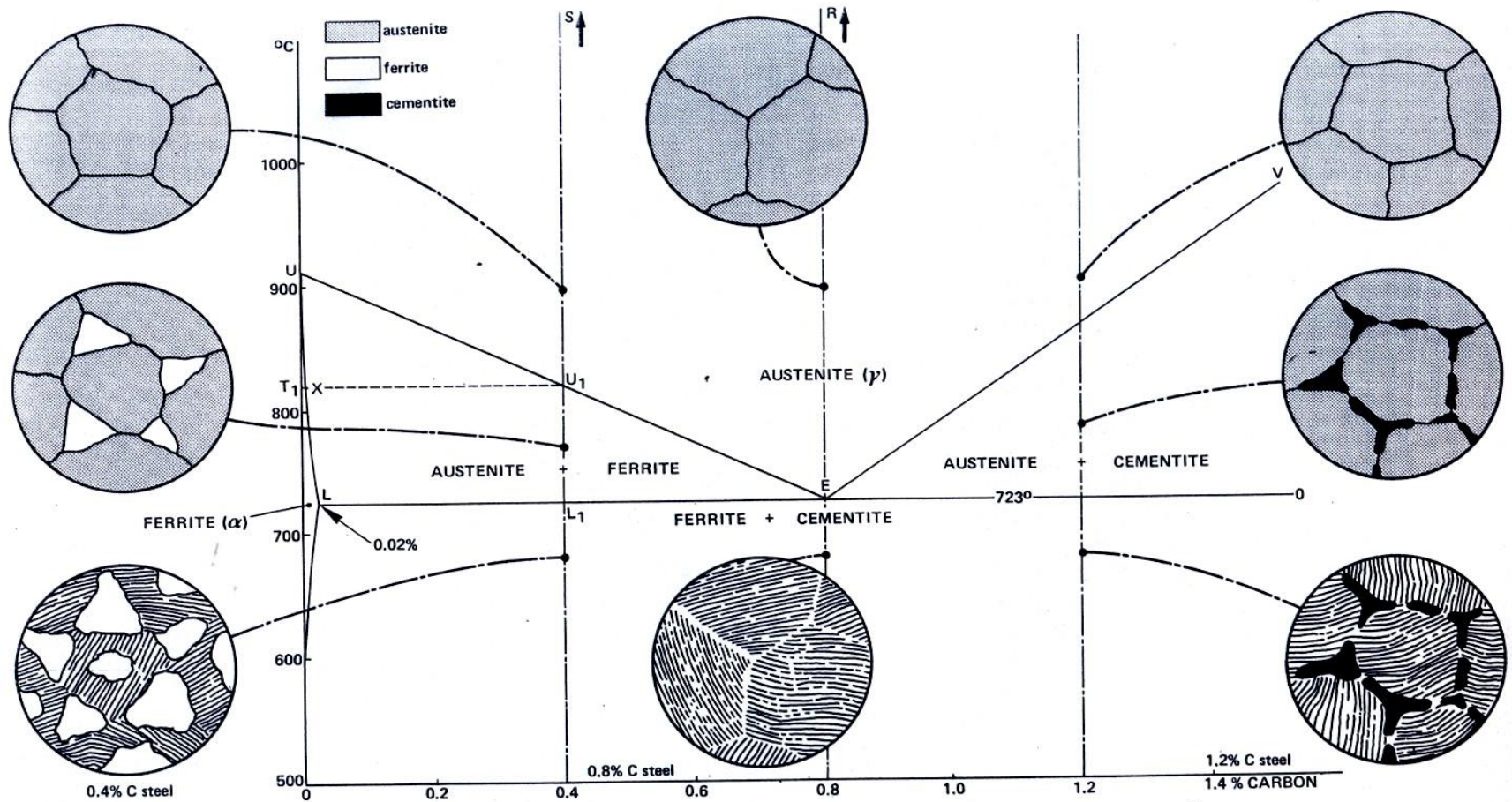

Fig. 9.3—The austenite → ferrite/cementite transformation in relation to the iron-carbon diagram.

The Austenite to ferrite / cementite transformation in relation to Fe-C diagram

- The iron wants to change crystal structure from the FCC austenite to the BCC ferrite, but the ferrite can only contain 0.02% carbon in solid solution.
- The excess carbon is rejected and forms the carbon-rich intermetallic known as cementite.

The Austenite to ferrite / cementite transformation in relation to Fe-C diagram



**Hypo-eutectoid steel showing primary cementite along grain boundaries
pearlite**

The Austenite to ferrite / cementite transformation in relation to Fe-C diagram

- **Hypo-eutectoid steels:** Steels having less than 0.8% carbon are called *hypo-eutectoid steels* (*hypo* means "less than").
- Consider the cooling of a typical hypo-eutectoid alloy along line $y-y'$.
- At high temperatures the material is entirely austenite.
- Upon cooling it enters a region where the stable phases are ferrite and austenite.
- The low-carbon ferrite nucleates and grows, leaving the remaining austenite richer in carbon.

The Austenite to ferrite / cementite transformation in relation to Fe-C diagram

- **Hyper-eutectoid steels** (*hyper* means "greater than") are those that contain more than the eutectoid amount of Carbon.
- When such a steel cools, as along line $z-z'$, the process is similar to the hypo-eutectoid steel, except that the primary or pro-eutectoid phase is now cementite instead of ferrite.

Principal phases of steel and their Characteristics

Phase	Crystal structure	Characteristics
Ferrite	BCC	Soft, ductile, magnetic
Austenite	FCC	Soft, moderate strength, non-magnetic
Cementite	Compound of Iron & Carbon Fe₃C	Hard & brittle

Applications

- It is used tailor properties of steel and to heat treat them.
- It is also used for comparison of crystal structures for metallurgists in case of rupture or fatigue

LECTURE NOTES

HEAT TREATMENT

Course Objective

The aim of this course is to gain an understanding of the role of heat treatment on the development of microstructure and properties of metallic materials. The course will highlight a number of commercially-significant applications where heat treatment are important.

Course Overview

This course covers the theory of heat treatment including the kinetic principles of solid state transformations. The influence of time on phase transformation is investigated. The interpretation of IT and CT diagrams to predict transformations and resulting microstructures is covered. Hardenability of steel is studied including factors influencing hardenability and the use of hardenability curves in the selection of steels for given applications. The effect of thermal gradients and phase transformations on distortion and residual stress in heat treated products is studied. With addition of this it covers heat treatment of some selected non-ferrous alloys and ferrous alloys.

Learning Outcomes

the course is to supply the student with a basic understanding of the modern heat treatment processes and reheating principles. Upon completing the required coursework, the student can explain the reasons for the heat treatment and its effects on the final properties of the product. With the help of a short theoretical background.

CONTENTS

Chapter	Chapter Name	Slide No
1	Foundation	6-55
2	Principles of heat treatment of steels	56-133
3	Heat treatment processes for steels	134-170
4	Hardenability	171-196
5	Quenching technology	197-231
6	Surface hardening treatment of steels	232-241
7	Thermo chemical treatments of steels	242-259
8	Thermo mechanical treatment	260-272
9	Cast irons	273-308
10	Heat treatment of selected steels	309-334
11	Heat treatment of non ferrous alloys	335-395

MM-15-015 HEAT TREATMENT

REFERENCES

- ❑ Steel heat treatment : Metallurgy and Technologies

Geroge E. Totten

CRC Press , Taylor & Francis Group

- ❑ Heat Treatment : Principles and Techniques

T.V.Rajan, C.P.Sharma and Ashok Sharma

PHI Learning Private Limited

- ❑ Heat Treatment of Materials

Vijendra Singh

Standard Publishers Distributors, Delhi

- ❑ Phase Transformations & Heat Treatment

Prof. M.P.Gururajan

NPTEL web course

- ❑ Practical Heat Treating

Howard E. Boyer

American society for metals

- ❑ Introduction to Physical Metallurgy

Sidney H. Avner

McGraw Hill Education (India) Pvt Ltd



Foundation

Objective

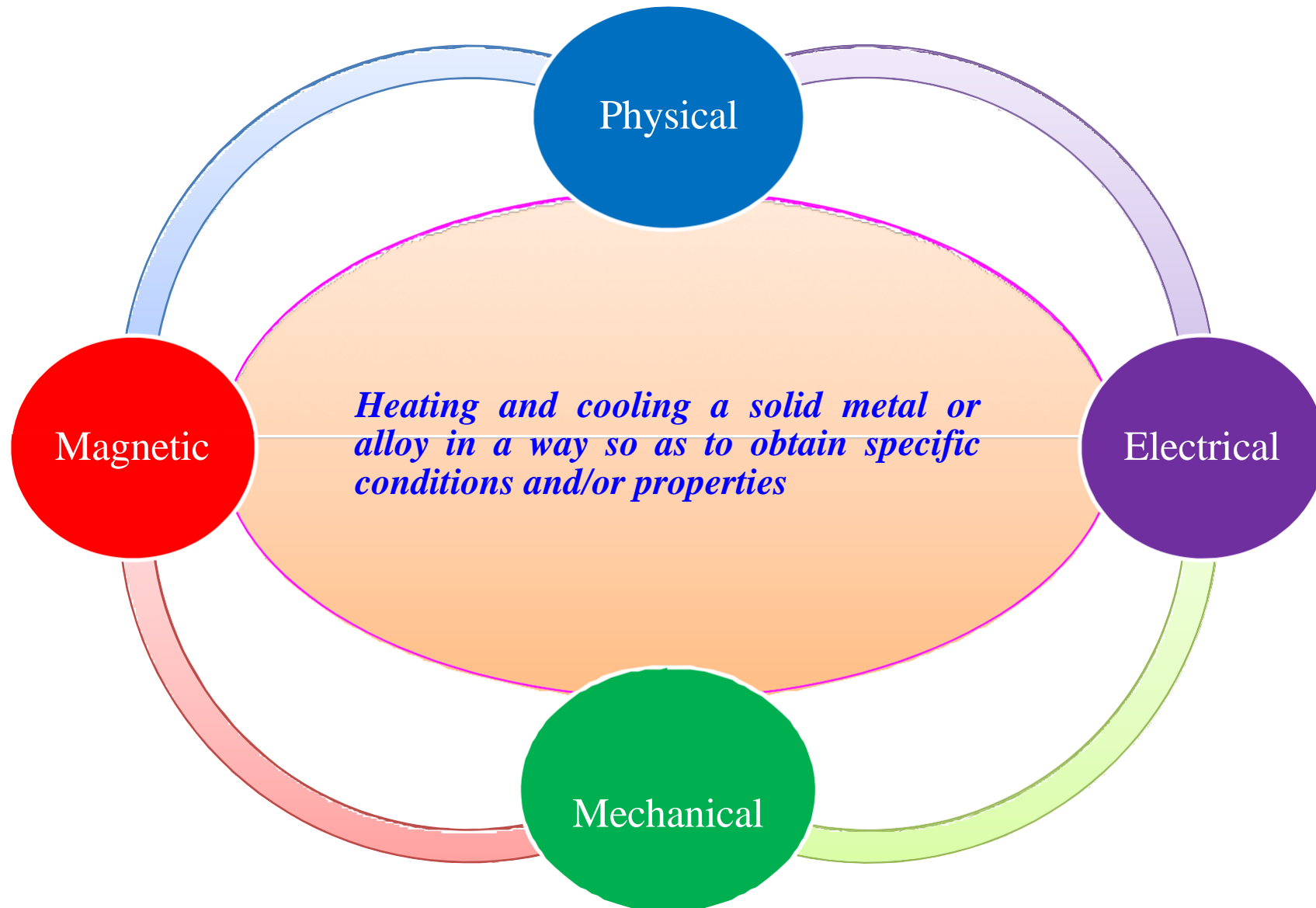

Objective

- ❑ To increase strength, hardness and wear resistance (*bulk hardening, surface hardening*)
- ❑ To increase ductility and softness (*Tempering, Recrystallization Annealing*)
- ❑ To increase toughness (*Tempering, Recrystallization annealing*)
- ❑ To obtain fine grain size (*Recrystallization annealing, Full annealing, Normalizing*)
- ❑ To remove internal stresses induced by differential deformation by cold working, non-uniform cooling from high temperature during casting and welding (*Stress relief annealing*)
- ❑ To improve machinability (*Full annealing and Normalizing*)
- ❑ To improve cutting properties of tool steels (*Hardening and Tempering*)
- ❑ To improve surface properties (*surface hardening, high temperature resistance-precipitation hardening, surface treatment*)
- ❑ To improve electrical properties (*Recrystallization, Tempering, Age hardening*)
- ❑ To improve magnetic properties (*Hardening, Phase transformation*)

Heat Treatment Process variables

Temperature

Holding time

Heating rate

Cooling rate

Furnace atmosphere

Classification of steels

- ❑ Compositions, such as carbon (or non alloy), low -alloy, and alloy steels
- ❑ Manufacturing methods , such as converter, electric furnace, or electroslag remelting methods
- ❑ Application or main characteristic, such as structural , tool, stainless steel, or heatresistant steels.
- ❑ Finishing methods, such as hot rolling, cold rolling, casting, or controlled rolling and controlled cooling.
- ❑ Product shape, such as bar, plate, strip, tubing, or structural shape
- ❑ Oxidation practice employed, such as rimmed, killed, semikilled, and capped steels.
- ❑ Microstructure, such as ferritic, pearlitic, martensitic, and austenitic
- ❑ Required strength level, as specified in the American Society for Testing and Materials (ASTM) standards.
- ❑ Heat treatment, such as annealing, quenching and tempering, air cooling (normalization), and thermo-mechanical processing.
- ❑ Quality descriptors and classifications, such as forging quality and commercial quality.

Classification of steels

Steels

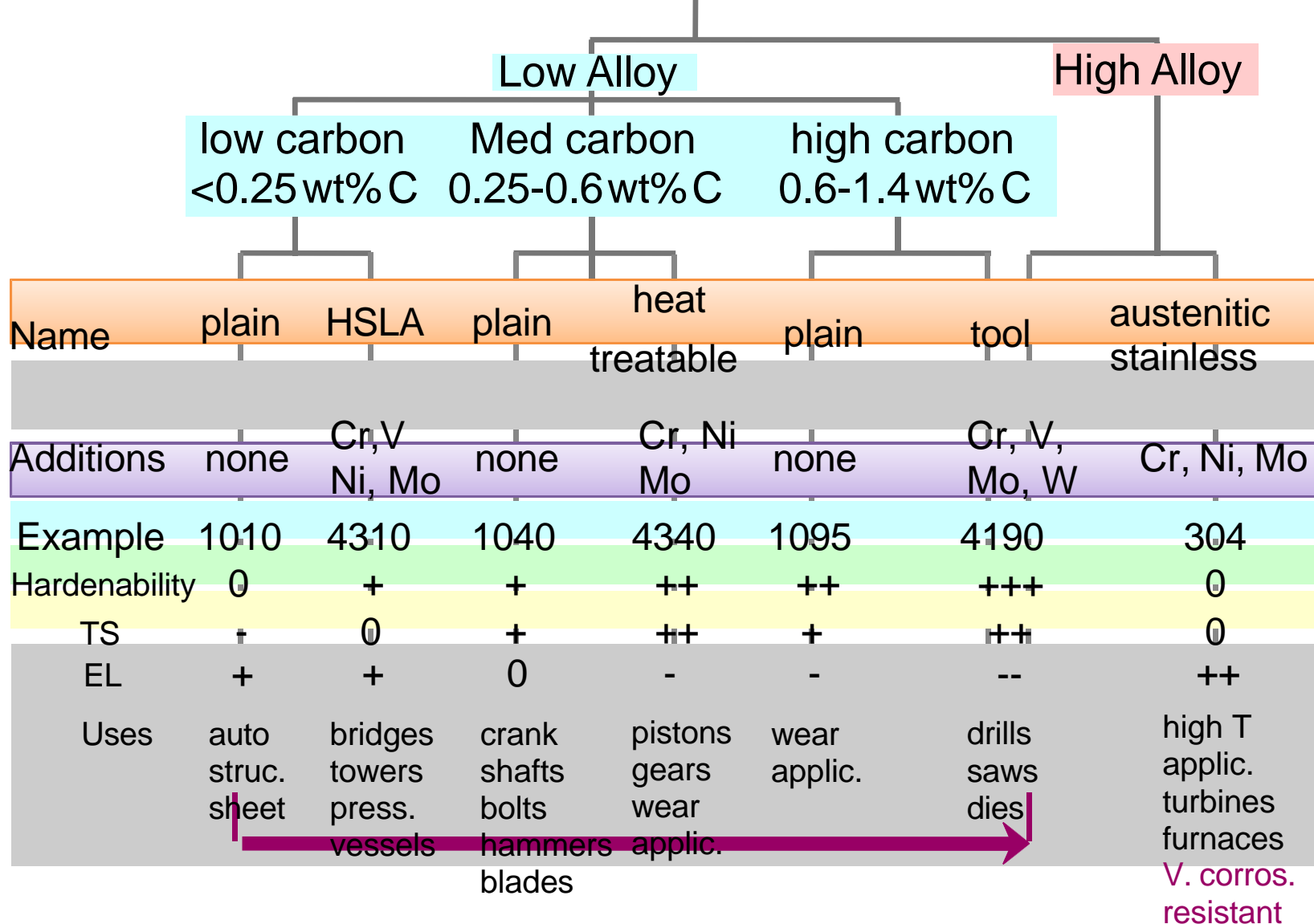

Allotropic Transformation in Iron

- Iron is an allotropic metal, which means that it can exist in more than one type of lattice structure depending upon temperature. A cooling curve for pure iron is shown below:

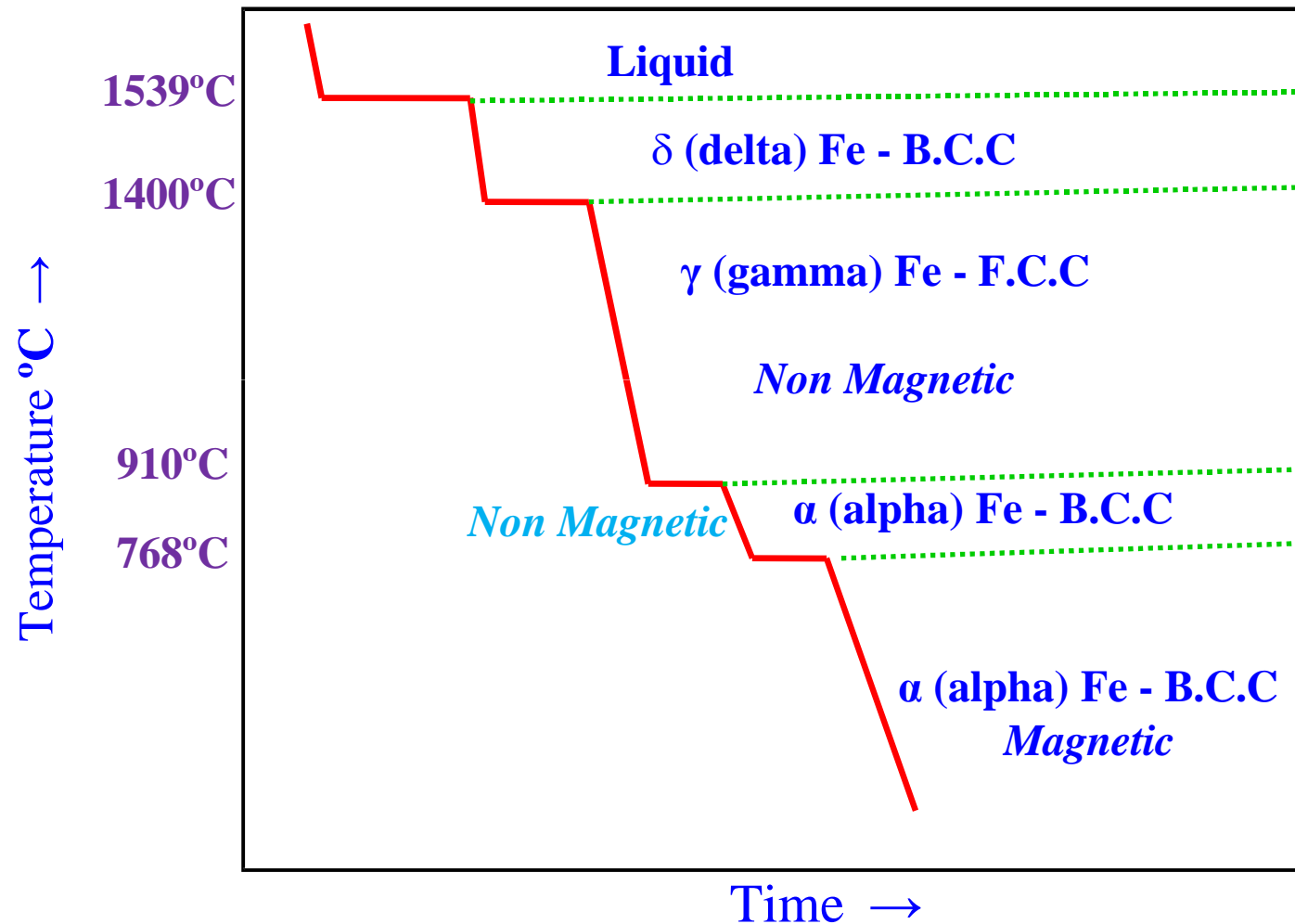

Can be other allotropic structures are possible....?

Effect of pressure on allotropy of Iron

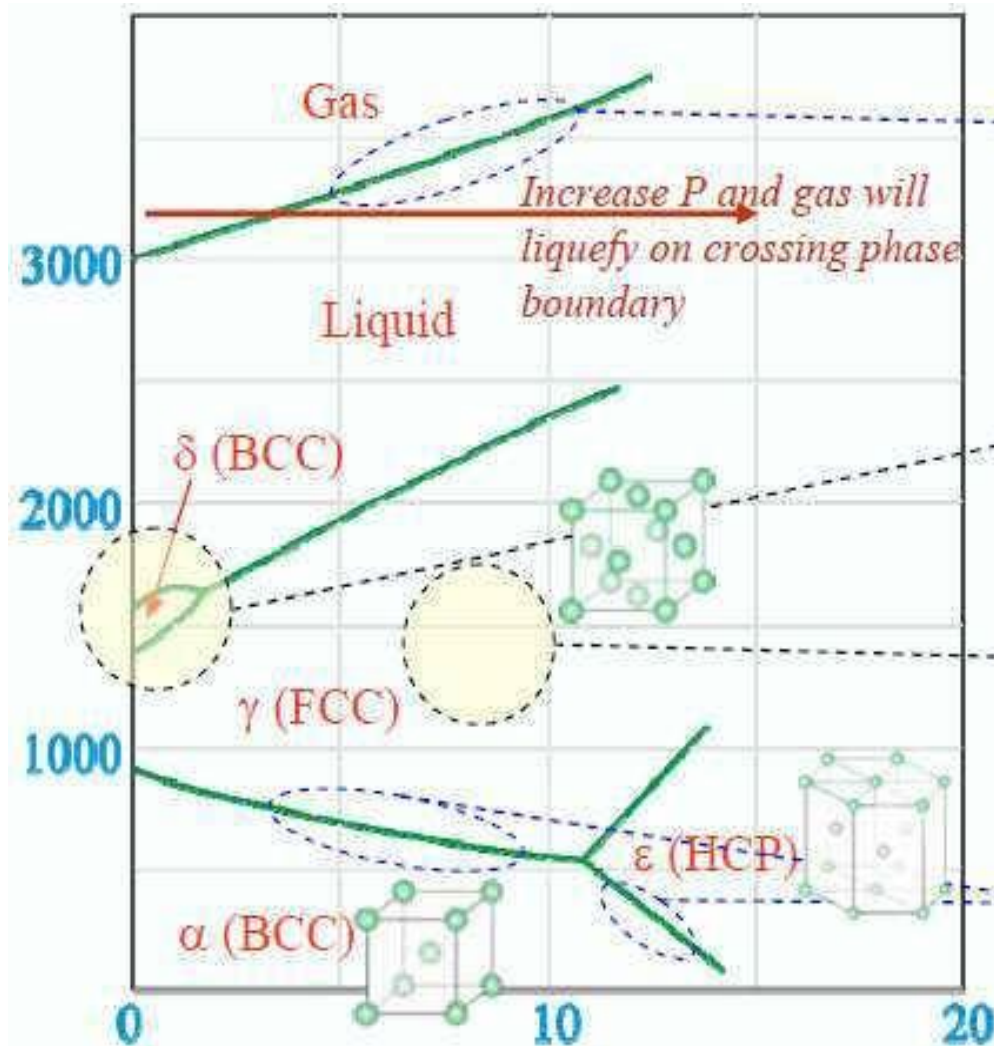

This line slopes upward as at constant T if we increase the P the gas will liquefy as liquid has lower volume (similarly the reader should draw horizontal lines to understand the effect of pressure on the stability of various phases- and rationalize the same).

Phase fields of non-close packed structures shrink under higher pressure

Phase fields of close packed structures expand under higher pressure

These lines slope downward as: Under higher pressure the phase with higher packing fraction (lower volume) is preferred

The face centered tetragonal (FCT) iron is coherently deposited iron grown as thin film on a {100} plane of copper substrate. Growing Trigonal iron on mis-fiting {111} surface of a face centered cubic copper substrate.

Iron - Cementite phase diagram

- ❑ The Fe-C (or more precisely the Fe-Fe₃C) diagram is an important one. Cementite is a metastable phase and ‘strictly speaking’ should not be included in a phase diagram. But the decomposition rate of cementite is small and hence can be thought of as ‘stable enough’ to be included in a phase diagram. Hence, we typically consider the Fe-Fe₃C part of the Fe-C phase diagram.
- ❑ In the phase diagram, temperature is plotted against composition. Any point on the diagram therefore represents a definite composition and temperature. The phase diagram indicates the phases present and the phase changes that occur during heating and cooling. The relative amounts of the phases that exist at any temperature can also be estimated with the help of lever rule.
- ❑ A portion of the Fe-C diagram – the part from pure Fe to 6.67 wt.% carbon (*corresponding to cementite, Fe₃C*) – *is technologically very relevant.*
- ❑ Cementite is not an equilibrium phase and would tend to decompose into Fe and graphite. This reaction is sluggish and for practical purpose (at the microstructural level) cementite can be considered to be part of the phase diagram. Cementite forms as it nucleates readily as compared to graphite.
- ❑ Compositions upto 2.1% C are called steels and beyond 2.1% are called cast irons. *In reality the classification should be based on ‘castability’ and not just on carbon content.*
- ❑ Heat treatments can be done to alter the properties of the steel by modifying the microstructure → we will learn about this in coming chapters.

Fe-Fe₃C metastable phase diagram

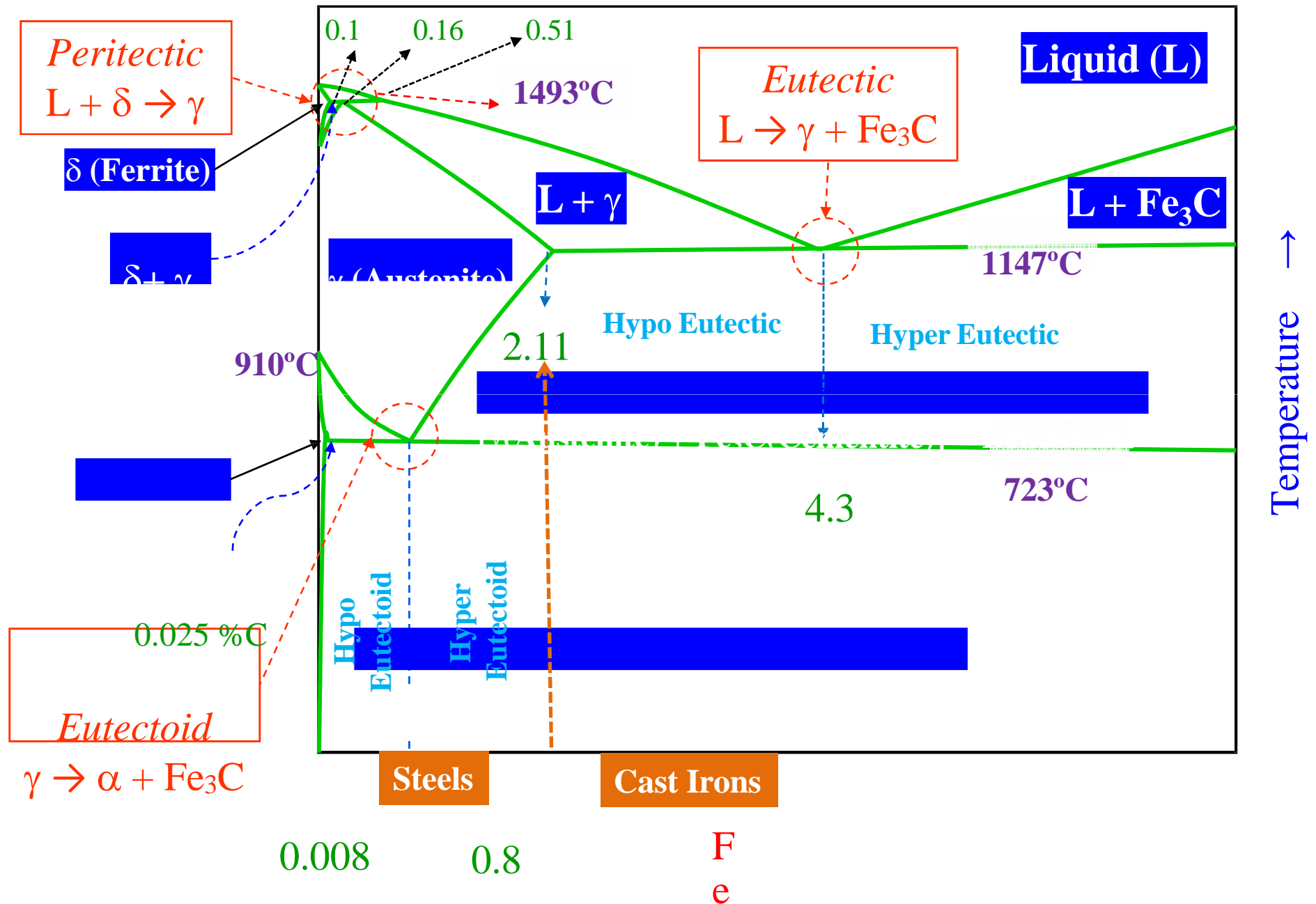

Fe-Fe₃C metastable phase diagram

% Carbon



6
7
F
e
3
C

1
4

Carbon Solubility in Iron



Solubility of carbon in Fe = f (structure, temperature)

Where is carbon located in iron lattice ?

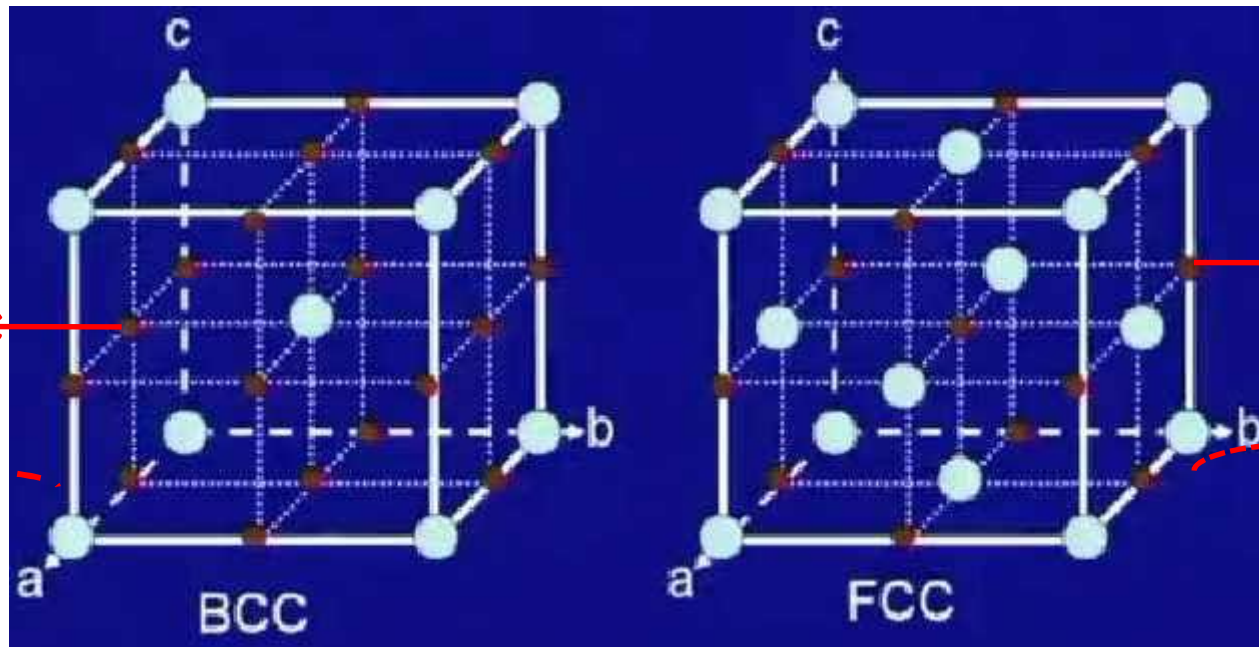

Octahedral sites

Octahedral sites

6 faces sharing with two sides $(6/2)=3$
12 edges sharing with four sides $(12/4)=3$
Total sites is $(3+3)$, 6 per unit cell
Every one Fe atom we have 3 interstitial sites

One interstitial site in center plus
12 edges sharing with four sides $(12/4)=3$
Total sites is $(1+3)$, 4 per unit cell
Every one Fe atom we have 1 interstitial site

Why concentration of carbon in α -Fe with BCC structure is less than γ -Fe with FCC structure?

- ❑ FIRST LET US CONSIDER FCC STRUCTURE (γ -Fe)
- ❑ Packing factor of FCC lattice 0.74
- ❑ This indicates the presence of voids. Let us discuss it more elaborately.
- ❑ In a FCC crystal there are mainly two types of voids:
- ❑ Tetrahedral: coordination number (CN) is 4. That means the void is surrounded by 4 atoms.
- ❑ Octahedral: CN is 6. That means the void is surrounded by 6 atoms.
- ❑ There are 8 tetrahedral voids in a unit cell. That means 2 voids per atom.
- ❑ There are 4 octahedral voids in a unit cell. That means 1 void per atom.
- ❑ However, impurities prefer to occupy octahedral voids.
- ❑ Because the ratio of the radius of the tetrahedral void to atom is 0.225 and the same for the octahedral void is 0.414.
- ❑ The ratio of the radius of the carbon atom (size is 77 pm) to Fe (when it has FCC crystal) is 0.596.
- ❑ So when a carbon atom occupies any void, lattice will be distorted to increase the enthalpy.
- ❑ Distortion will be less if it occupies the octahedral voids.
- ❑ Although it increases the enthalpy, carbon atoms will be present up to a certain extent because of the gain in entropy, as explained previously, which decreases the free energy.

Carbon Solubility in Iron

FCC

Size of Fe atom
CCP crystal

$$r_{FCC}^{Fe} = 1.292 \text{ \AA}$$

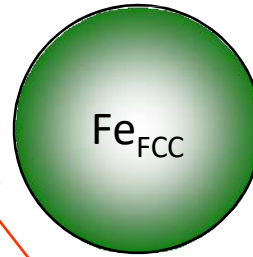

Void (Oct)

Void (Tet)

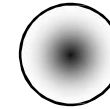
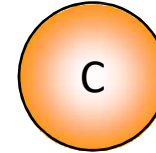

Size of the OV

$$x_{FCC}^{Fe} (oct) = 0.534 \text{ \AA}$$

Relative sizes of voids w.r.t atoms

Size of Carbon atom

$$r^C = 0.77 \text{ \AA}$$

Note the difference in size of the atoms

BCC

Size of Fe atom
BCC crystal

$$r_{BCC}^{Fe} = 1.258 \text{ \AA}$$

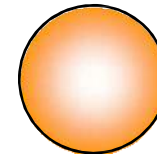
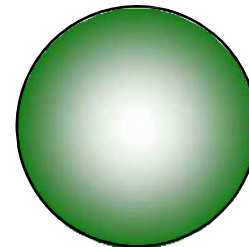

Void (Oct)

Void (Tet)

Size of the TV

$$x_{BCC}^{Fe} (d.tet) = 0.364 \text{ \AA}$$

Fe_{BCC}

C

Relative sizes of voids w.r.t atoms

Size of the OV

$$x_{BCC} (d.oct) = 0.195 \text{ \AA}$$



Remember

- ❑ **FCC** Size of the largest atom which can fit into the tetrahedral is 0.225 and octahedral void is 0.414
- ❑ **BCC** Size of the largest atom which can fit into the *d.tetrahedral* is 0.29 and *d.octahedral* void is 0.154

Why concentration of carbon in α -Fe with BCC structure is less than γ -Fe with FCC structure?

- ❑ NOW LET US CONSIDER THE BCC UNIT CELL (α - Fe)
- ❑ Packing factor of BCC lattice 0.68. So total void in a BCC unit cell is higher than FCC cell.
- ❑ However, there are 12 (6 per atom) tetrahedral and 6 (3 per atom) octahedral voids present. This number is higher than the number of voids present in a FCC unit cell.
- ❑ Unlike voids in FCC lattice, in a BCC lattice the voids are distorted. That means if an atom sits in a void, it will not touch all the host atoms.
- ❑ The ratio of the radius of tetrahedral void to atom is 0.29 and the radius of octahedral void to atom is 0.155.
- ❑ The ratio of the radius of the C atom (size is 77 pm) to Fe (when it has BCC crystal) is 0.612. So it is expected that in a BCC unit cell, impurities should prefer tetrahedral voids.
- ❑ However, although the octahedral void size is small, planar radius which has 4 atoms on the same plane is 79.6 pm, which is larger than the C atom size. That means it needs to distort only other two atoms.
- ❑ On the other hand if C sits in the tetrahedral void it has to distort all four atoms. So in α - Fe with BCC unit cell C occupies the octahedral voids
- ❑ Now the octahedral void size in γ -Fe (FCC) is higher than α -Fe (BCC). So naturally the distortion in a BCC cell will be higher and the activation energy for impurities to occupy a void in a BCC cell also will be higher.
- ❑ This is the reason that we find much lower solubility limit of C in α -Fe.

Why carbon preferentially sits in the apparently smaller octahedral void in BCC ?

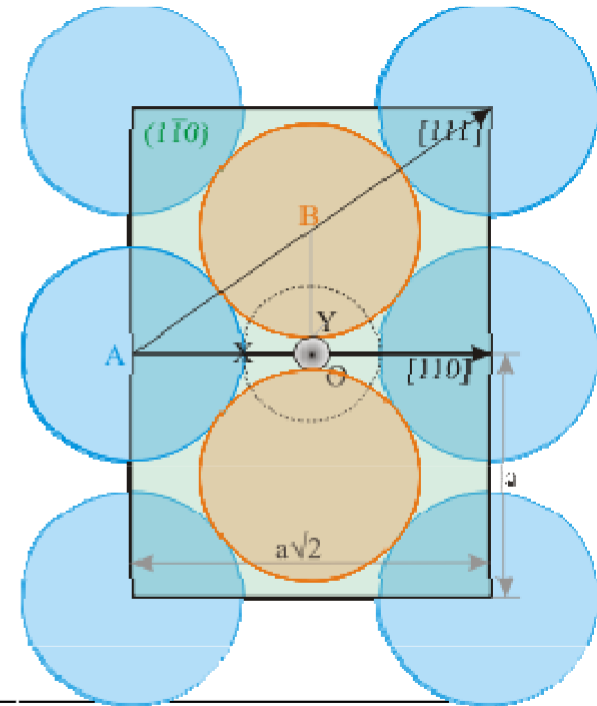
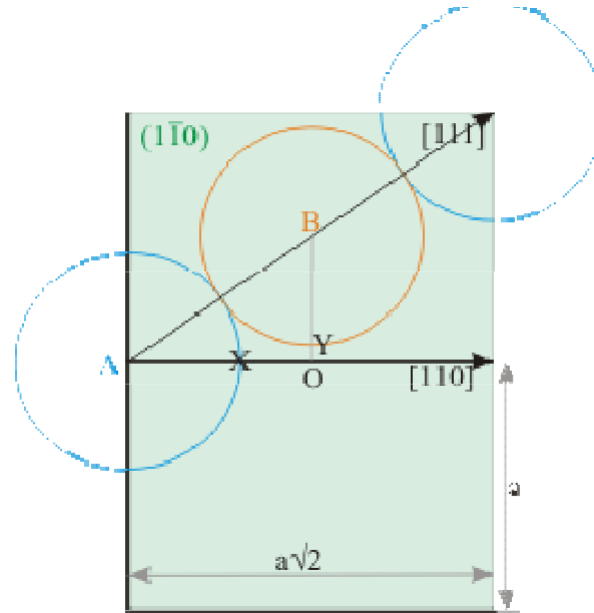
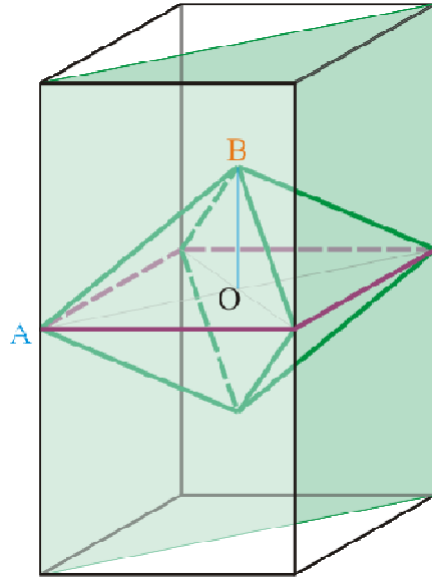

Ignoring the atom sitting at B and assuming the interstitial atom touches the atom at A

$$OA = r + x_A = \frac{\sqrt{2}a}{2}$$

$$r + x_A = \frac{2\sqrt{6}r}{3}$$

$$\frac{x_A}{r} = \left(\frac{2\sqrt{6}}{3} - 1 \right) = 0.6329$$

$$r_{BCC}^{Fe} = 1.258 \text{ \AA}$$

$$BCC : \sqrt{3}a = 4r$$

$$x^{Fe} (d.tet) =$$

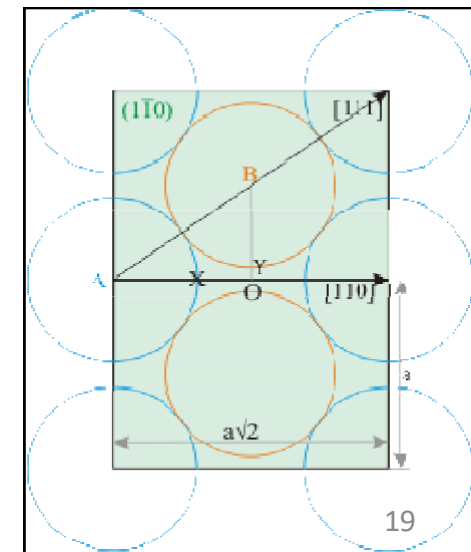

$$OX = x_A = 0.796 \text{ \AA} \quad OY = x_B = 0.195 \text{ \AA} \quad \text{BCC} \quad 0.364 \text{ \AA}$$

Characteristics of phases appeared in Fe-Fe₃C phase diagram

Ferrite (α)

- ❑ It is an interstitial solid solution of a small amount of carbon dissolved in α iron. The maximum solubility is 0.025% C at 723°C and it dissolves only 0.008% C at room temperature. *It is the softest structure that appears on the diagram.*
- ❑ *Ferrite is ferromagnetic at low temperatures but loses its magnetic properties with the rise of temperatures with major loss at curies temperatures, 768°C and above this temperature, it becomes non magnetic (paramagnetic).*
- ❑ The crystal structure of ferrite (α) is B.C.C
- ❑ Tensile strength – 245 Mpa, Yield strength 118 Mpa
- ❑ Elongation – 40-50% in 2 in.
- ❑ Hardness - 95 VHN

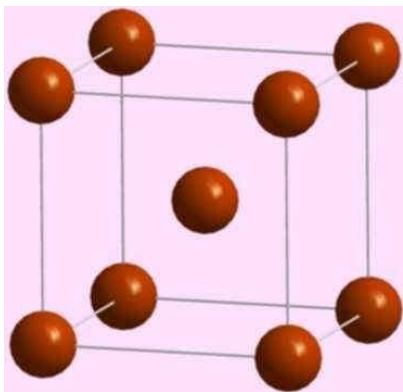

α (Ferrite) contains
B.C.C structure

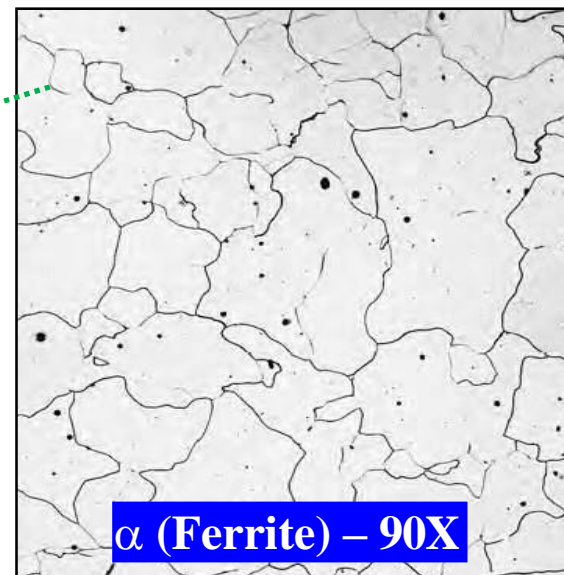

α (Ferrite) – 90X

Cementite (Fe₃C)

- ❑ Cementite or iron carbide, chemical formula Fe₃C, contains 6.67% C by weight and it is a metastable phase.
- ❑ It is typically hard and brittle interstitial compound of low tensile strength (35 Mpa) but high compressive strength and high hardness ~800VPN.
- ❑ It is the hardest structure that appears on the diagram.
- ❑ It has a complex orthorhombic crystal structure with 12 iron atoms and 4 carbon atoms per unitcell.
- ❑ It is slightly ferromagnetic up to 210°C and paramagnetic above it. Melting point around 1227°C.

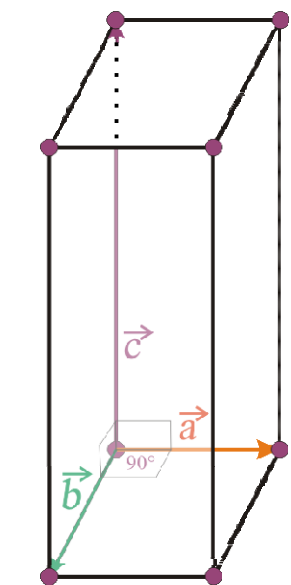

Orthorhombic

**Carbon
(4 atoms)**

**Iron
(12 atoms)**

$a \neq b \neq c$
 $\alpha = \beta = \gamma = 90^\circ$

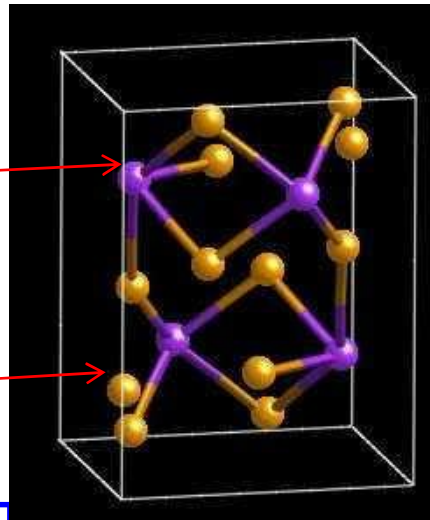

Cementite network

Pearlite ($\alpha + \text{Fe}_3\text{C}$)

- ❑ Pearlite is the eutectoid mixture containing 0.80 %C and is formed at 723°C on very slow cooling.
- ❑ It is very fine platelike or lamellar mixture of ferrite and cementite. The fine fingerprint mixture called pearlite is shown in below figure.
- ❑ The weight % of these two phases are thus in ratio 8:1
- ❑ Tensile strength – 120,000 psi or 825 Mpa
- ❑ Elongation – 20 percent in 2 in.
- ❑ Hardness – HRC 20, HRB 95-100, or BHN 250-300

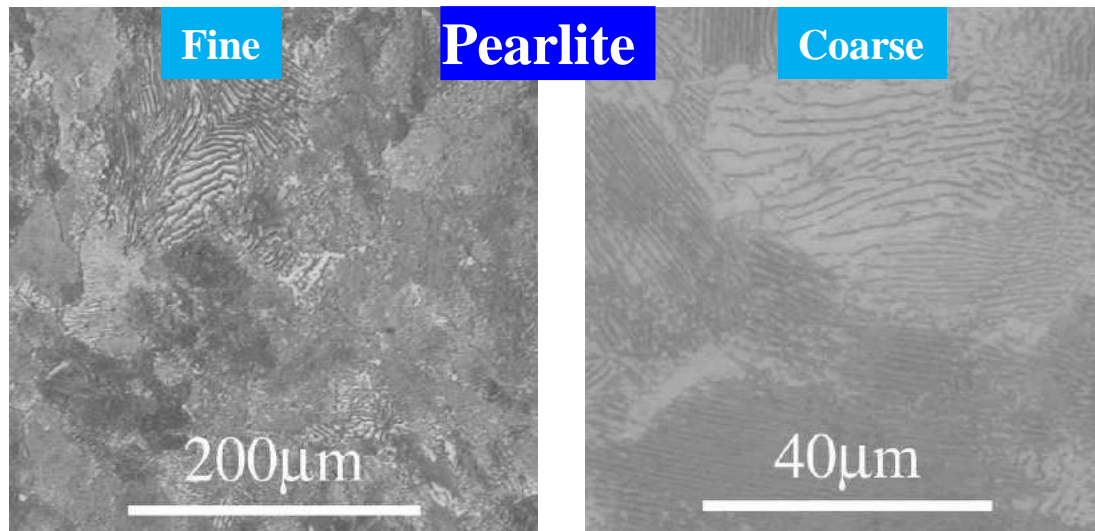
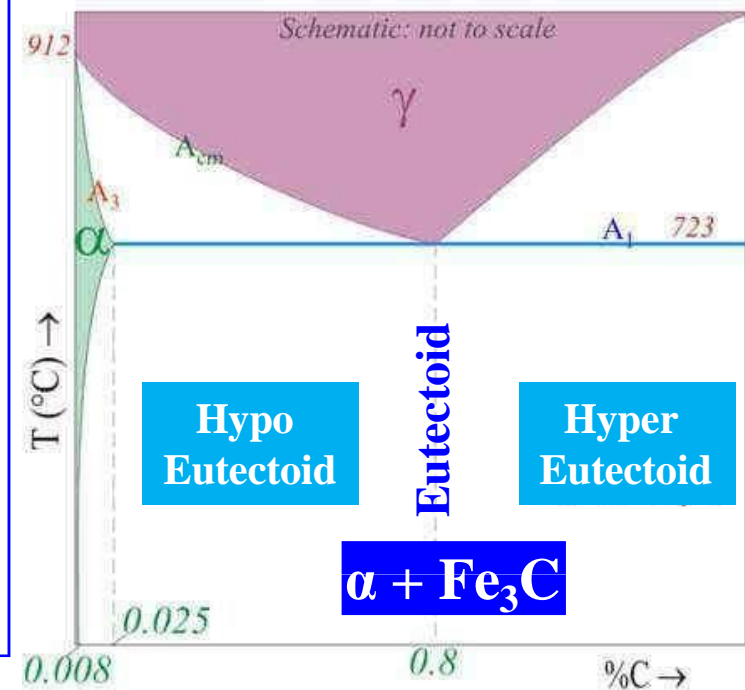

Remember...!

Pearlite is a not a phase but combination of two phases (ferrite + cementite)

Austenite (γ)

- ❑ It is an interstitial solid solution of a small amount of carbon dissolved in γ iron and has FCC crystal structure. The maximum solubility is 2.1% C at 1147°C.
- ❑ Austenite is soft, ductile tough and malleable (FCC structure) and non magnetic (paramagnetic).
- ❑ Steels are commonly rolled and forged above about 1100°C when they are in austenite state due to its high ductility and malleability, which is also due to its FCC structure.
- ❑ Tensile strength – 150,000 psi or 1035 Mpa
- ❑ Elongation – 10% in 2 in.
- ❑ Hardness - 395 VPN and Toughness is high.

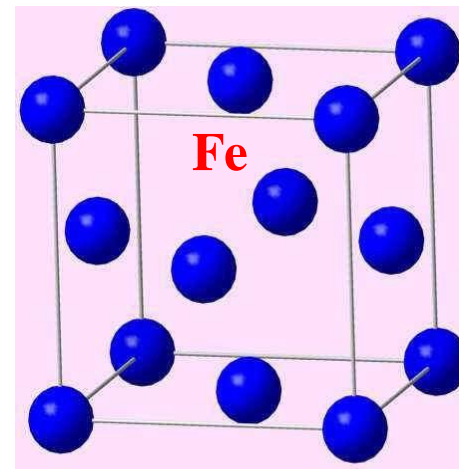
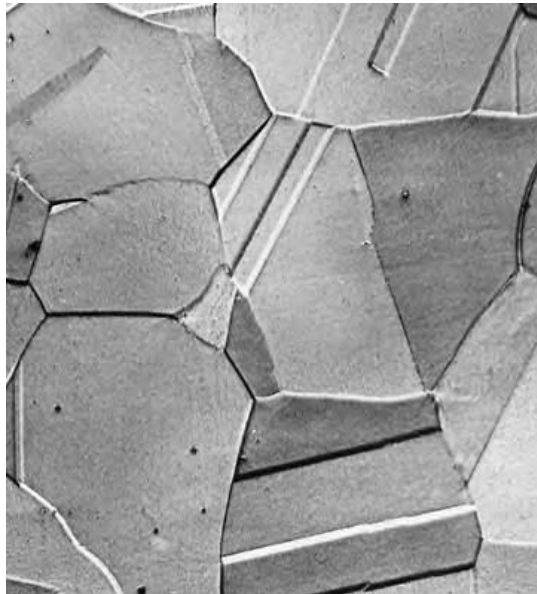

Ledeburite ($\gamma + \text{Fe}_3\text{C}$)

- ❑ Ledeburite is the eutectic mixture of austenite and cementite. It contains 4.3% C and is formed at 1147°C
- ❑ Structure of ledeburite contains small islands of austenite are dispersed in the carbide phase.
- ❑ Not stable at room temperature

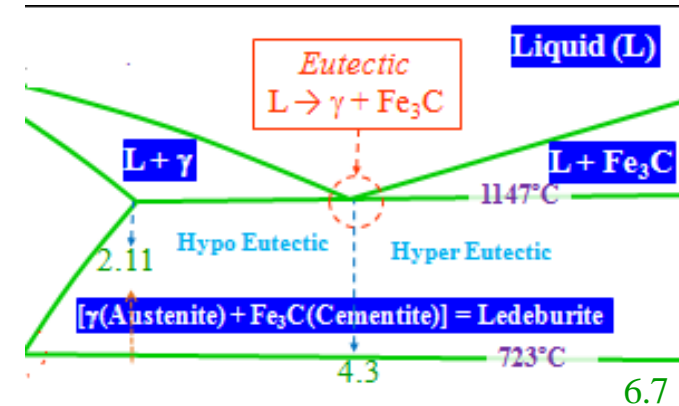

The pearlite is resolved in some regions where the sectioning plane makes a glancing angle to the lamellae. The ledeburite eutectic is highlighted by the arrows. At high temperatures this is a mixture of austenite and cementite formed from liquid. The austenite subsequently decomposes to pearlite.

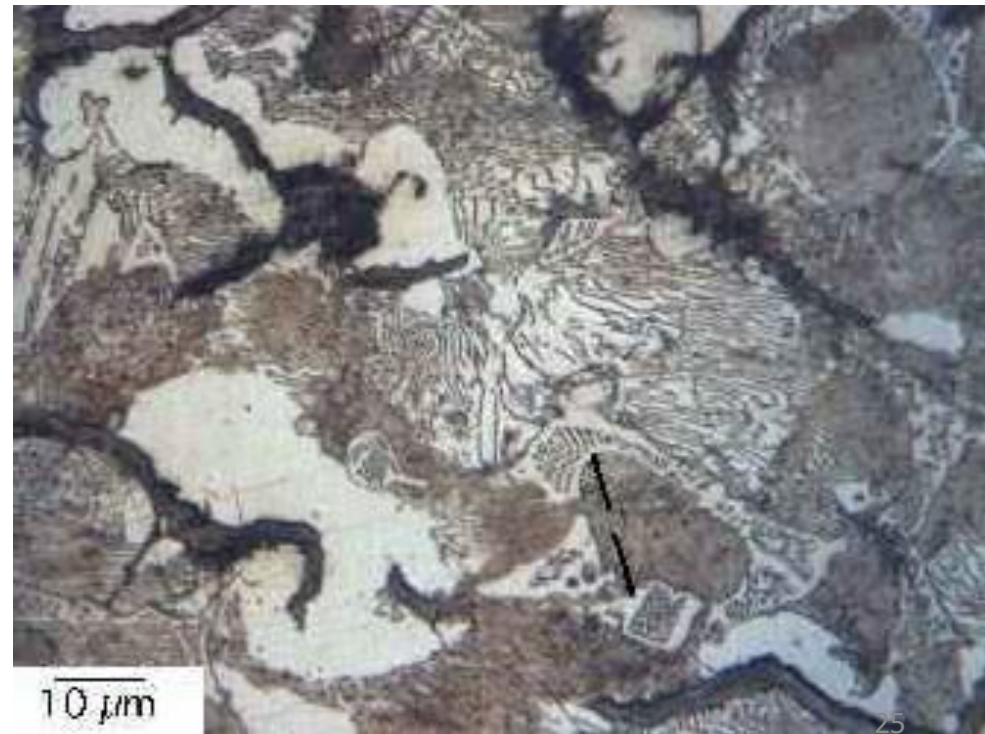

Ferrite (δ)

- ❑ Interstitial solid solution of carbon in iron of body centered cubic crystal structure. (δ iron) of higher lattice parameter (2.89\AA) having solubility limit of 0.09 wt% at 1495°C with respect to austenite. The stability of the phase ranges between $1394\text{-}1539^\circ\text{C}$.
- ❑ It is a high temperature phase and is a high temperature manifestation of α ferrite.

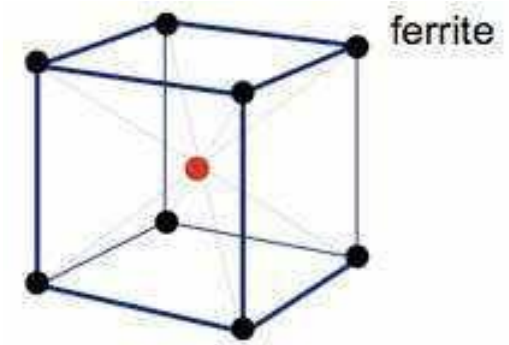

- ❑ This is not stable at room temperature in plain carbon steel. However it can be present at room temperature in alloy steel specially duplex stainless steel.

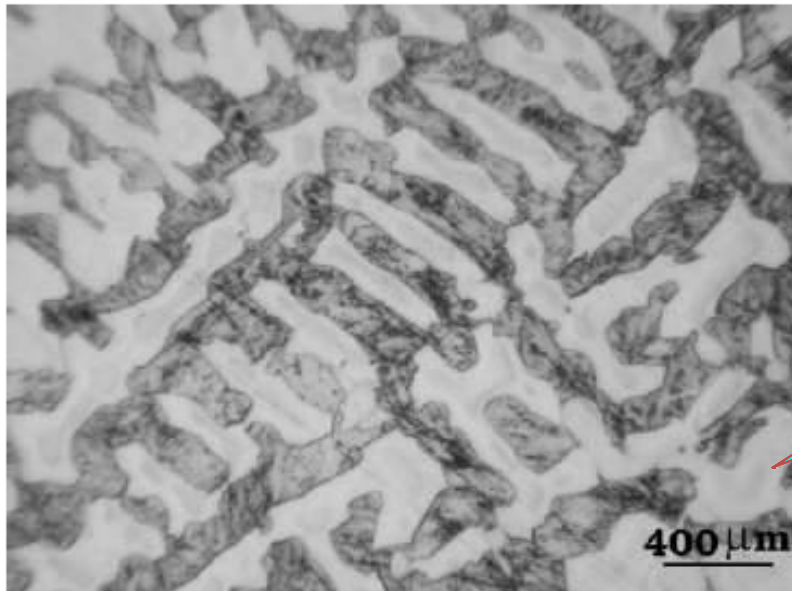

δ -ferrite in dendrite form
in as-cast Fe-0.4C-2Mn-
0.5Si-2 Al0.5Cu

Invariant Reactions in Fe-Fe₃C Phase Diagram

Peritectic Reaction

- ❑ The invariant peritectic reaction in Fe-Fe₃C diagram is given by

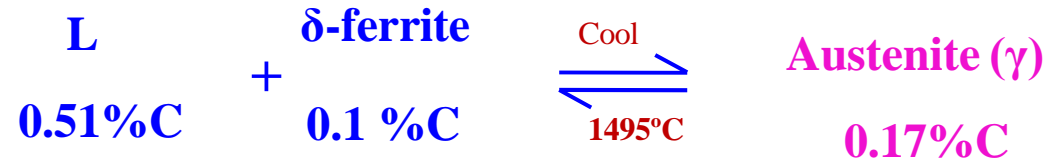

- ❑ Thus Liquid, wt% is $L = \frac{0.16 - 0.1}{0.51 - 0.1} \times 100 = 14.63\%$

- ❑ Thus δ ferrite, wt % is $= \frac{0.51 - 0.16}{0.51 - 0.1} \times =$

- ❑ Fe-0.16%C steel is a peritectic steel because only this steel undergoes above reaction completely.
- ❑ Peritectic reaction is of some importance during freezing of steels (carbon from 0.1 to 0.51% particularly under fast cooling conditions, when micro segregation may result, otherwise no commercial heat treatment is done in this region.
- ❑ Unfortunately these temperatures are attained during heating of steels for forging or rolling etc., then severe overheating and burning results in steels turning them to scrap form.

Eutectic Reaction

- The invariant Eutectic reaction in Fe-Fe₃C diagram is given by

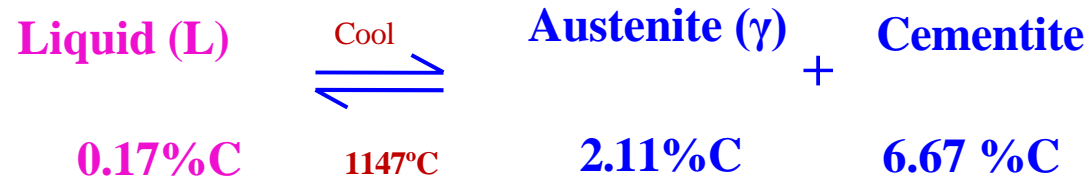

- Thus Austenite, wt% is $\gamma = \frac{6.67 - 4.3}{6.67 - 2.11} \times 100 = 51.97\%$

- Thus cementite, wt % is $Fe_3C = \frac{4.3 - 2.11}{6.67 - 2.11} \times 100 = 48.03\%$

- Fe-4.3%C alloy is called eutectic cast iron as it is the lowest melting point alloy, which is single phase liquid (100%) of 4.3% carbon at the eutectic temperature, 1147°C just attained and undergoes eutectic reaction completely at this constant eutectic temperature to give a mixture of two different solids, namely austenite and cementite, solidifying simultaneously. The eutectic mixture called *Ledeburite*.

- As Fe-C alloys having more than 2.11% carbon are classed as cast irons, the Fe-C alloys having carbon between 2.11 and 4.3% are called *hypo eutectic cast irons*, where as those having carbon between 4.3% and 6.67% are called *hypereutectic cast irons*. Alloys of Fe with

4.3% carbon is called *eutectic cast iron*.

Eutectic Reaction

Eutectoid Reaction

- ❑ The invariant Eutectoid reaction in Fe-Fe₃C diagram is given by



- ❑ Thus Ferrite, wt% is $\alpha = \frac{6.67 - 0.8}{6.67 - 0.02} \times 100 = 88\%$

- ❑ Thus cementite, wt % is $Fe_3C = \frac{0.8 - 0.02}{6.67 - 0.02} \times 100 = 12\%$

- ❑ During cooling austenite of 0.8% at constant eutectoid temperature, 727°C undergoes eutectoid transformation to form a mixture of ferrite (C%=0.02%) and cementite i.e., there are alternate lamellae of ferrite and cementite .
- ❑ This eutectoid mixture of ferrite and cementite is called **PEARLITE**, because of its pearly appearance under optical microscope.
- ❑ The weight % of these phases are thus 8:1. The densities are (α -7.87 gm/cm³) and (Fe₃C- - 7.70 gm/cm³) are quite comparable. Thus the Volume % also approx 8:1. Thus ferrite lamilla is 8 times thicker than cementite lamilla. as the two boundaries of cementite plate are close together, they may not resolved separately under the microscope, instead of two lines, it appears a single dark line.

Eutectoid Reaction

30

Eutectoid Reaction

- ❑ Phase changes that occur upon passing from the γ region into the $\alpha + \text{Fe}_3\text{C}$ phase field.
- ❑ Consider, for example, an alloy of eutectoid composition (0.8% C) as it is cooled from a temperature within the γ phase region, say 800°C – that is, beginning at point ‘a’ in figure and moving down vertical xx' . Initially the alloy is composed entirely of the austenite phase having composition 0.8 wt.% C and then transformed to $\alpha + \text{Fe}_3\text{C}$ [pearlite]
- ❑ The microstructure for this eutectoid steel that is slowly cooled through eutectoid temperature consists of alternating layers or lamellae of the two phases α and Fe_3C
- ❑ The pearlite exists as grains, often termed “colonies”; within each colony the layers are oriented in essentially the same direction, which varies from one colony to other.
- ❑ The thick light layers are the ferrite phase, and the cementite phase appears as thin lamellae most of which appear dark.

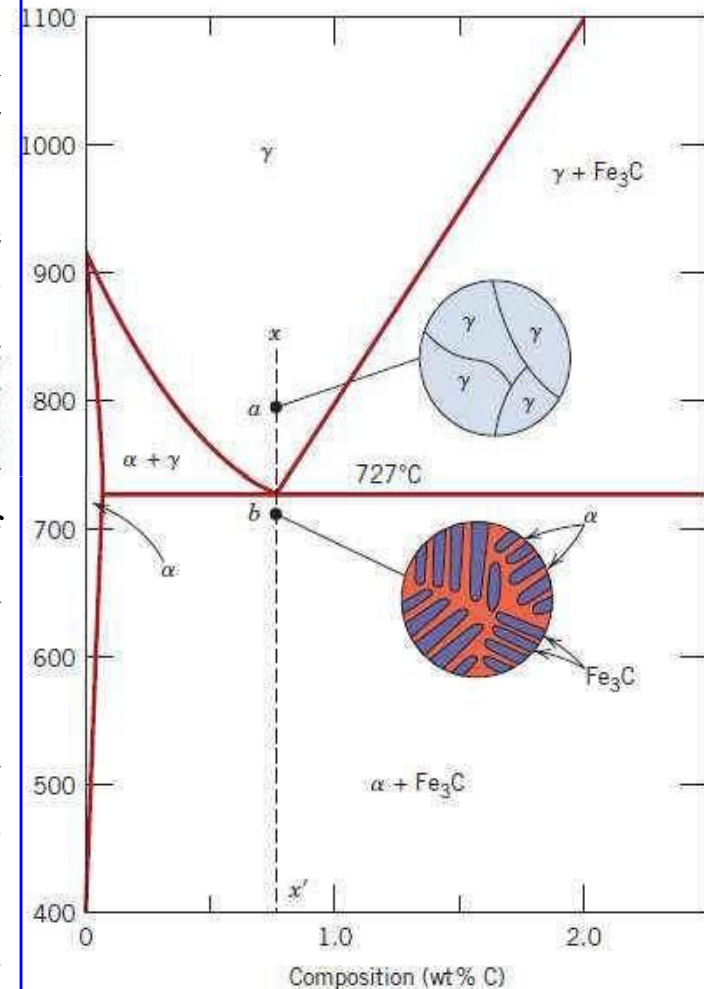

Eutectoid Structure

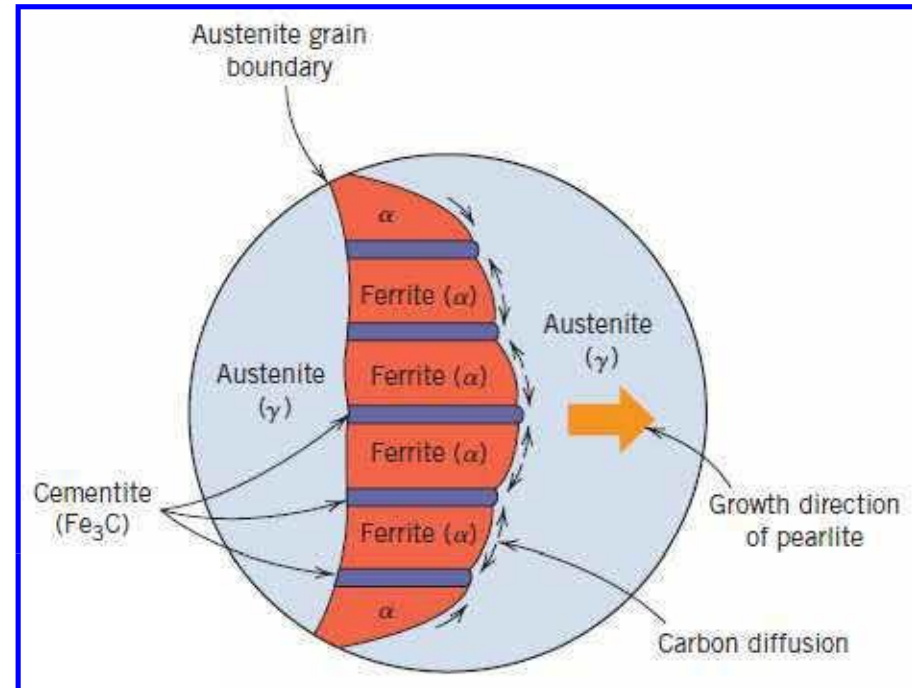
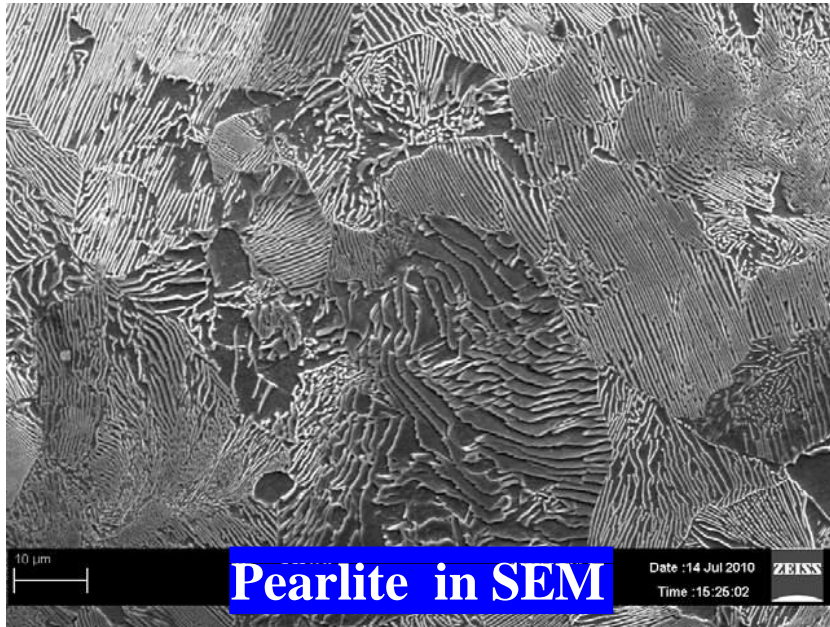

Schematic representation of the formation of pearlite from austenite; direction of carbon diffusion indicated by arrows

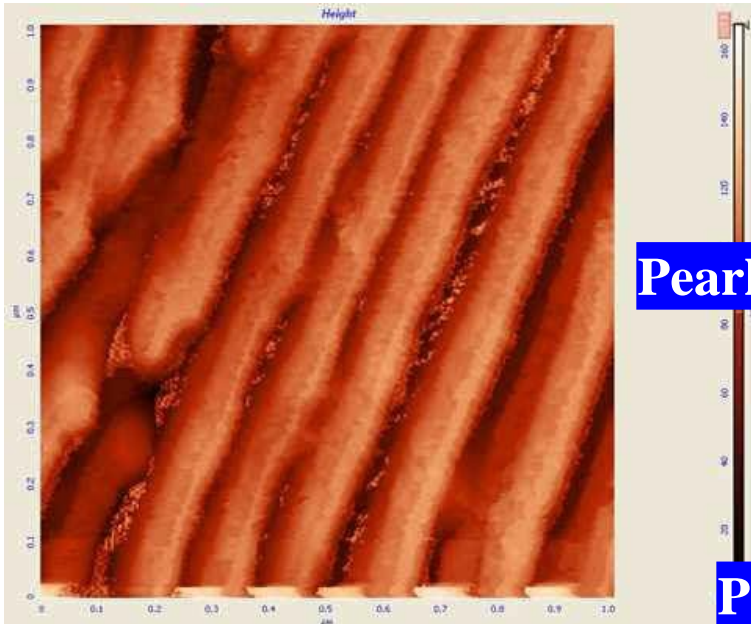

Pearlite in optical microscope

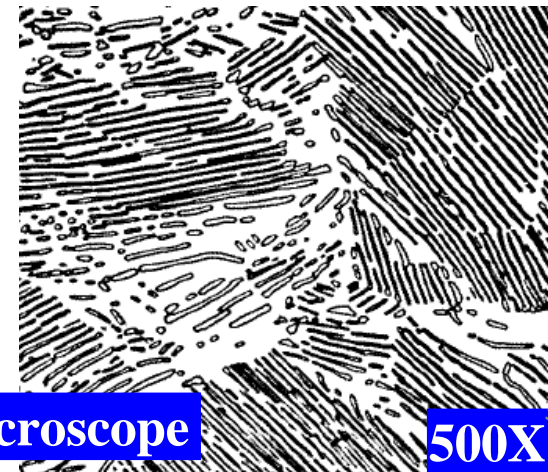

Hypo Eutectoid Region

- ❑ Hypo eutectoid region – 0.008 to 0.8 %C
- ❑ Consider vertical line yy' in figure, at about 875°C, point c , the microstructure will consist entirely of grains of the γ phase.
- ❑ In cooling to point d , about 775°C, which is within the $\alpha + \gamma$ phase region, both these phases will coexist as in the schematic microstructure. Most of the small α particles will form along the original γ grain boundaries.
- ❑ Cooling from point d to e , just above the eutectoid but still in the $\alpha + \gamma$ region, will produce an increased fraction of the α phase and a microstructure similar to that also shown: the α particles will have grown larger.

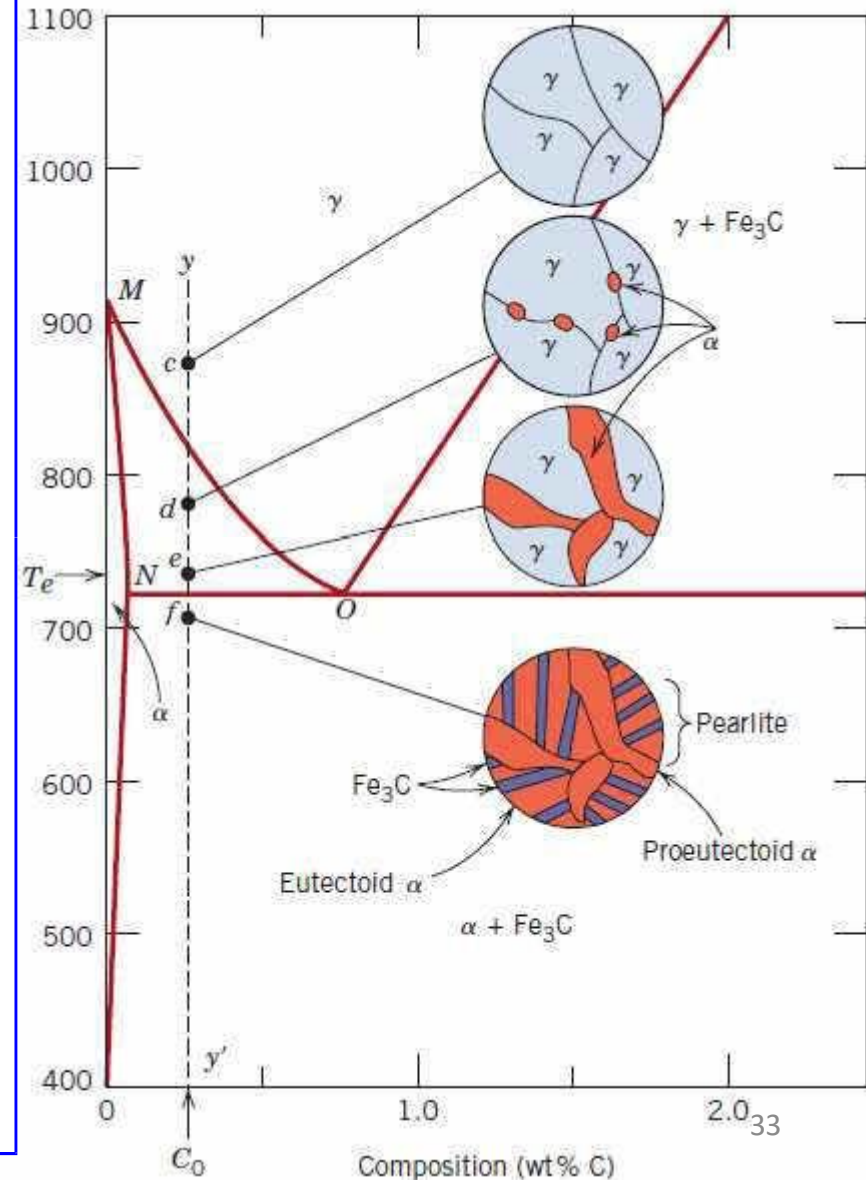

Hypo Eutectoid Region

- ❑ Just below the eutectoid temperature, at point **f**, all the γ phase that was present at temperature **e** will transform pearlite. Virtually there is no change in α phase that existed at point **e** in crossing the eutectoid temperature – it will normally be present as a continuous matrix phase surrounding the isolated pearlite colonies.
- ❑ Thus the ferrite phase will be present both in the pearlite and also as the phase that formed while cooling through the $\alpha+\gamma$ phase region. The ferrite that is present in the pearlite is called eutectoid ferrite, whereas the other, is termed proeutectoid (meaning pre- or before eutectoid) ferrite.

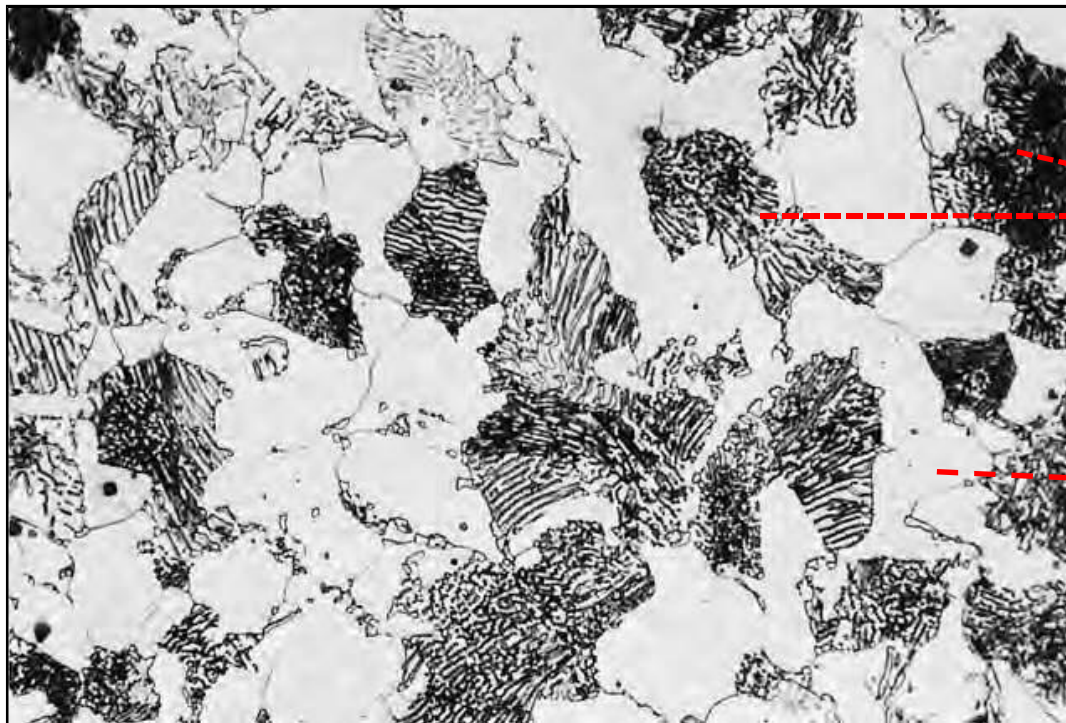

Pearlite

Pro-eutectoid ferrite

Hyper Eutectoid Region

- ❑ Hyper eutectoid region – 0.8 to 2.1 %C
- ❑ Consider an alloy of composition C_1 in figure that, upon cooling, moves down the line zz' . At point g only the γ phase will be present and the microstructure having only gamma grains.
- ❑ Upon cooling into the $\gamma + Fe_3C$ phase field – say to point h – the cementite phase will begin to form along the initial γ grain boundaries, similar to the α phase in point d . this cementite is called *proeutectoid cementite* that which forms before the eutectoid reaction.
- ❑ As the temperature is lowered through the eutectoid to point I , all remaining austenite of eutectoid composition is converted into pearlite; thus the resulting microstructure consists of pearlite and proeutectoid cementite as microconstituents.

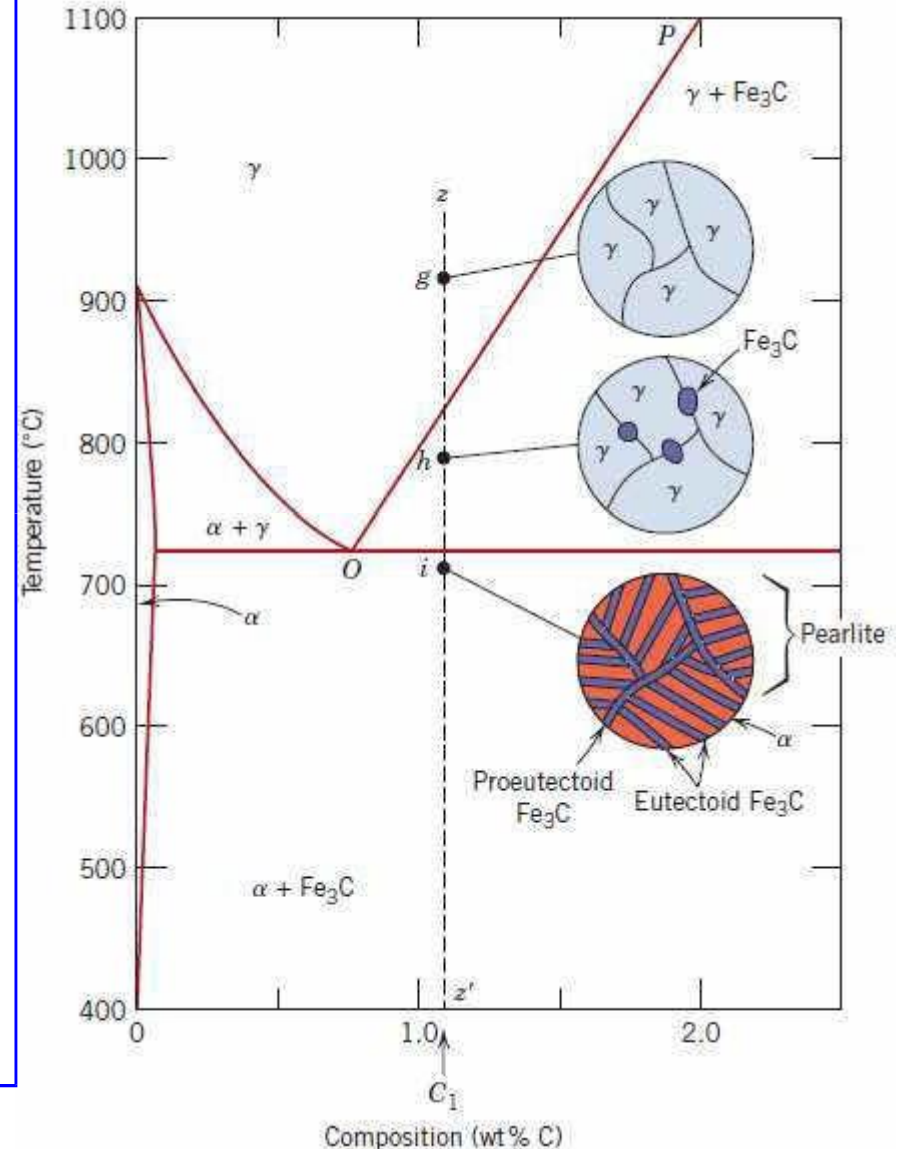

Hypo Eutectoid Region

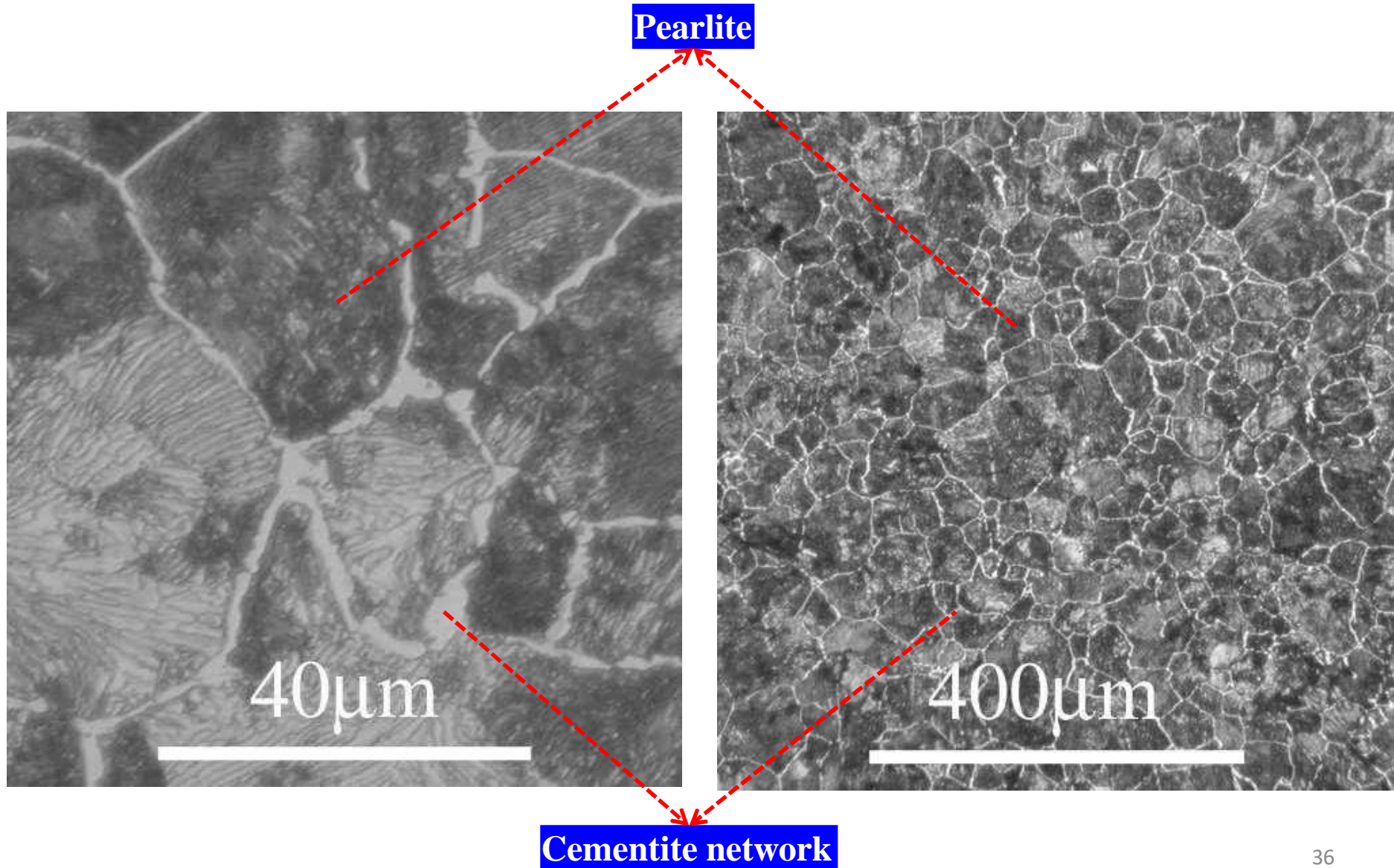

Concept of Primary Ferrite & Primary Cementite

- ❑ When the carbon content of steels is much away from the eutectoid carbon, then distinction can easily be made between hypoeutectoid steels and the hypereutectoid steel. Nital is the common etching agent.

Shape of the phases

- ❑ Proeutectoid ferrite appears as grains which are quite wide, polyhedral and the grain boundaries in between neighboring ferrite grains can be seen.
- ❑ The films of pro eutectoid cementite generally are much thinner, have irregular outlines and bounded by sharp lines. These are present as network of needles or platelets. Cementite looks much brighter and sharp because of its hardness and etching characteristics.
- ❑ Major difference is cementite is present as network at the grain boundaries of pearlite (at RT), whereas ferrite is present as grains (equiaxed polyhedral grains) with grain boundaries in between ferrite grains (if etched properly).

Microstructures of (a) Hypereutectoid steel (b) Hypoeutectoid steel

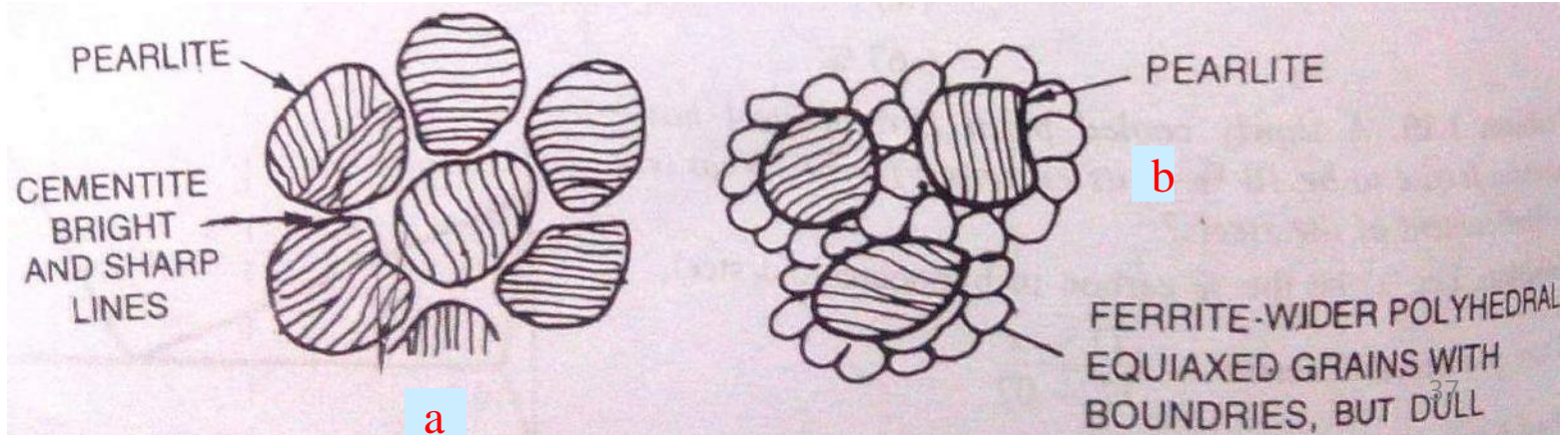

Concept of Primary Ferrite & Primary Cementite

Relative Hardness

- ❑ Cementite is very hard (~800 VPN) and ferrite is (~95 VPN). Micro hardness testing can be done to distinguish between ferrite and cementite.
- ❑ A simple scratch test can be done. Make a scratch on the polished and etched surface of the steel and then, examine the point of the scratch where it enters the white proeutectoid phase from the pearlite.
- ❑ If the scratch widens on entering, it is the soft phase ferrite, and if it thins in white phase, then the white phase is much harder than pearlite, i.e, it is cementite.

Relative hardness of ferrite and cementite distinguishes them (a) Hypereutectoid steel (b) Hypoeutectoid steel

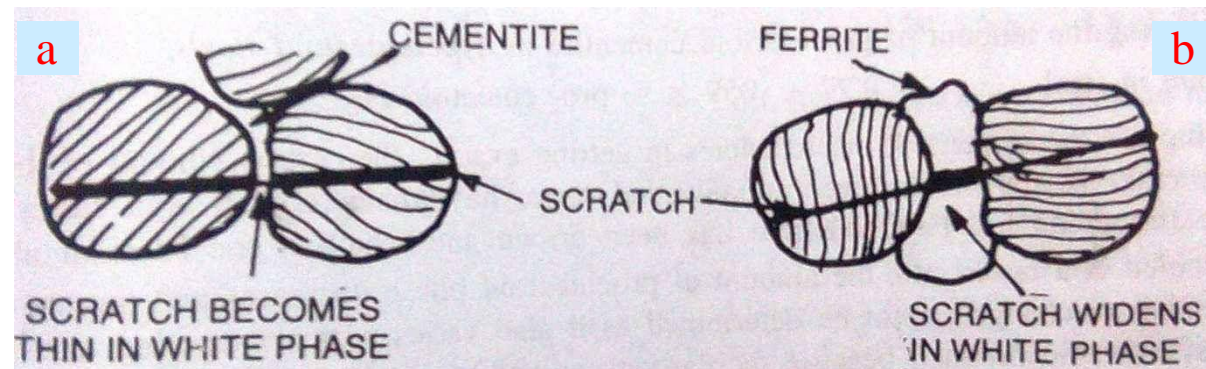

Special Etchants

- ❑ Nital etching causes cementite as well as ferrite to look white under microscope
- ❑ A sodium picrate solution used either boiling or electrolytically, darkens Fe_3C but not ' α '
- ❑ Another etchant based on sodium thiosulphate and ammonium nitrate gives color to ferrite but not cementite.

0.00005

Weight percent carbon

6.67

39

Evolution of Microstructures on equilibrium cooling

❑ Sequence of evolution of microstructure can be described by the projected cooling on compositions A, B, C, D, E, F.

❑ At composition A

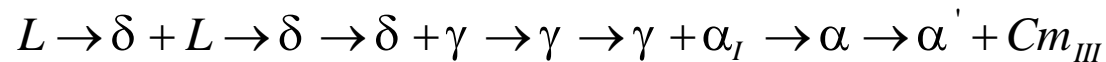

❑ At composition B

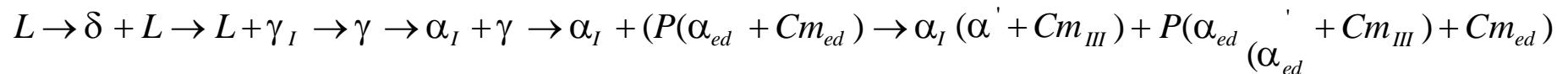

❑ At composition C

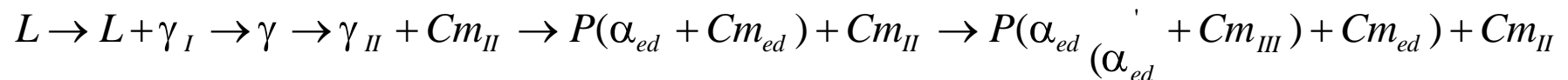

❑ At composition D

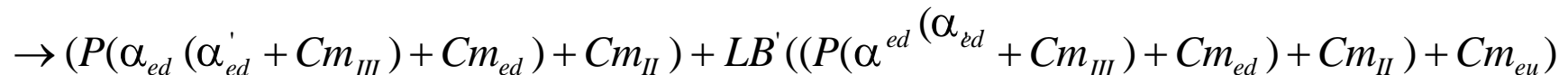
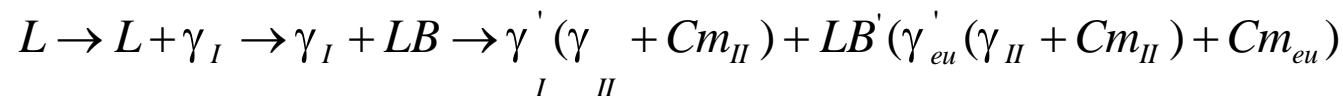

Evolution of Microstructures on equilibrium cooling

40



Evolution of Microstructures on equilibrium cooling

❑ Sequence of evolution of microstructure can be described by the projected cooling on compositions A, B, C, D, E, F.

❑ At composition E

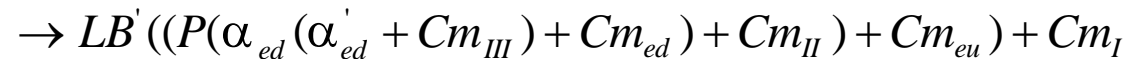
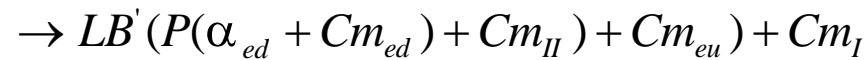
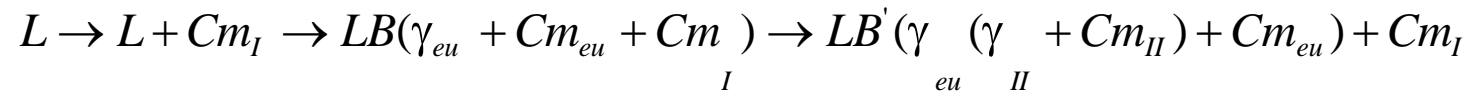

❑ At composition F

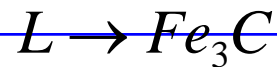

Evolution of Microstructures on equilibrium cooling⁴¹

Application of Lever rule in Fe-Fe₃C phase diagram

Solved Example

For a 99.6 wt% Fe-0.40 wt% C at a temperature just below the eutectoid, determine the following:

- The amount of Fe₃C, ferrite (α) and pearlite
- The amount of pearlite and proeutectoid ferrite (α)

a) The amount of Fe₃C and ferrite (α)

$$\text{Percentage of Fe}_3\text{C} = \frac{0.4 - 0.025}{6.67 - 0.025} * 100$$

Percentage of Fe₃C in 0.4 %C steel is 5.64 %

Percentage of Ferrite (α) in 0.4 %C steel = (100- 5.64)%

Percentage of ferrite in 0.4 %C steel = 94.36%

or

$$\text{Percentage of ferrite} = \frac{6.67 - 0.4}{6.67 - 0.025} * 100 = 94.36\%$$

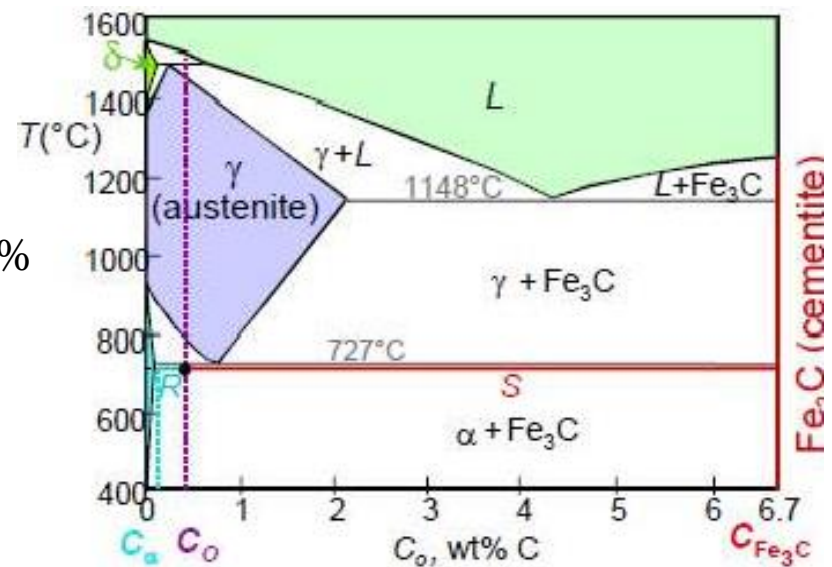
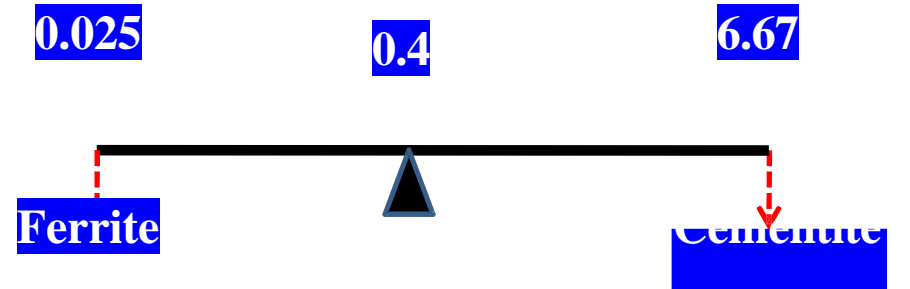

b) Phase fraction of pearlite and proeutectoid ferrite (α)

$$\text{Percentage of pearlite} = \frac{0.4 - 0.025}{0.8 - 0.025} * 100$$

Percentage of pearlite = 48 %

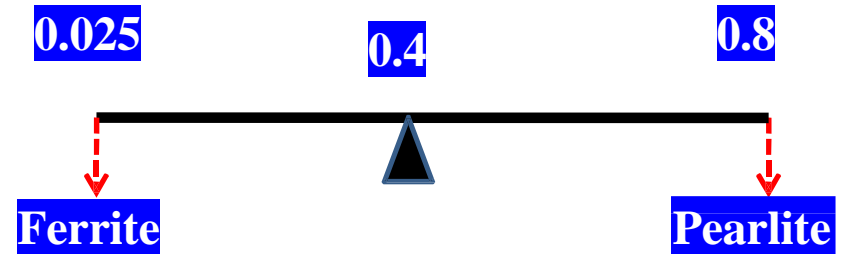

Percentage of proeutectoid ferrite (α) in 0.4 %C steel = (100- 48)%

Percentage of proeutectoid ferrite (α) = 52 %

or

$$\text{Percentage of proeutectoid ferrite} = \frac{0.8 - 0.4}{0.8 - 0.025} * 100 = 52\%$$

Critical Temperature lines

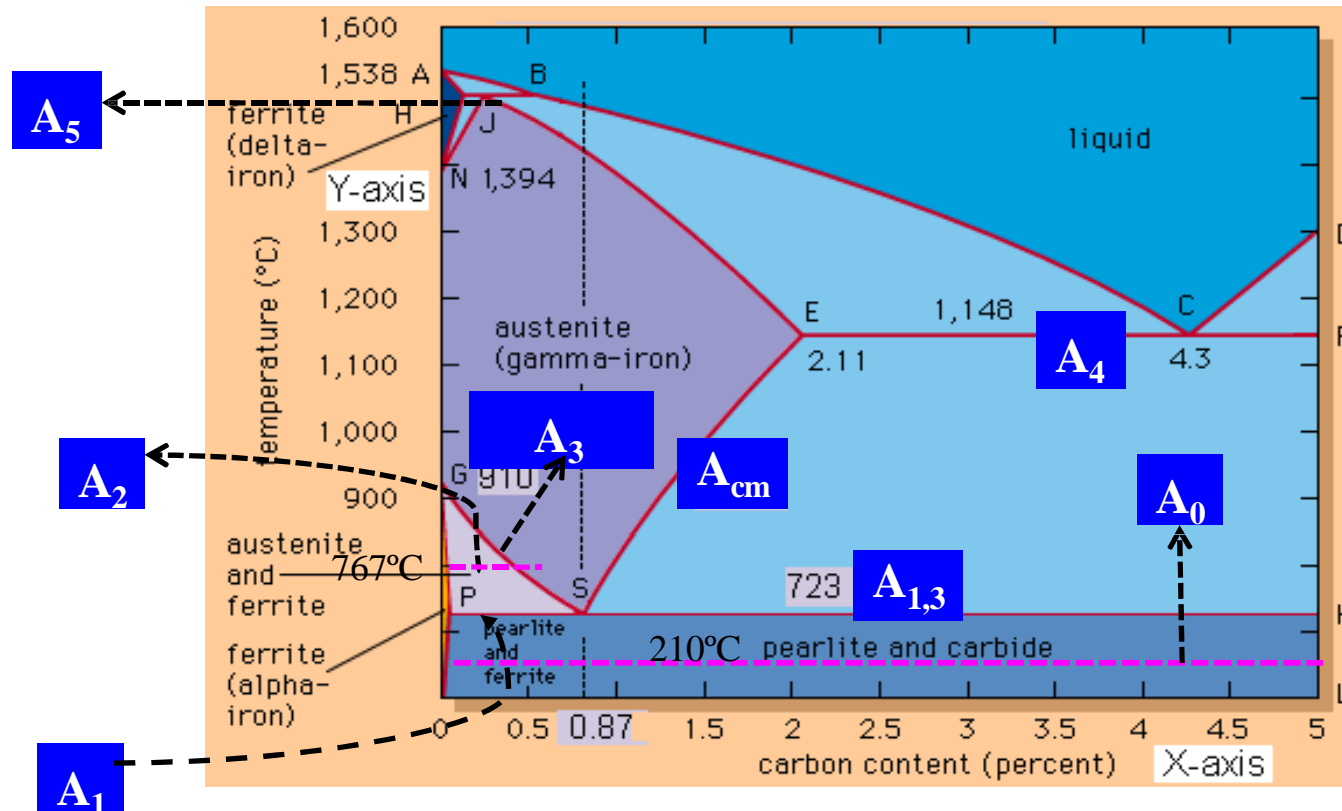

- ❑ In general, A_0 – Subcritical temperature, A_1 - lower critical temperature, A_3 - upper critical temperature, A_4 – Eutectic temperature, A_5 – Peritectic temperature and A_{cm} - γ/γ +cementite phase field boundary.
- ❑ While heating we denoted as Ac_1 , Ac_2 , Ac_3 etc., 'c' stands for *chauffage* (French word), which means heating and while cooling we denoted as Ar_1 , Ar_2 , Ar_3 etc., 'r' stands for *refroidissement*, (French word) which means cooling.

Critical Temperature lines

- ❑ The upper – and lower critical temperature lines are shown as single lines under equilibrium conditions and are sometimes indicated as A_{e3} , A_{e1} etc. When the critical lines are actually determined, it is found that they do not occur at the same temperature.
- ❑ The critical line on heating is always higher than the critical line on cooling. Therefore, the upper critical line of a hypo eutectoid steel on heating would be labeled A_{c3} and the same line on cooling A_{r3} . The rate of heating and cooling has a definite effect on the temperature gap between these lines.

The results of thermal analysis of a series of carbon steels with an average heating and cooling rate of 11°F/min are shown in figure.

Final word...! with infinitely slow heating and cooling they would probably occur at exactly the same temperature.

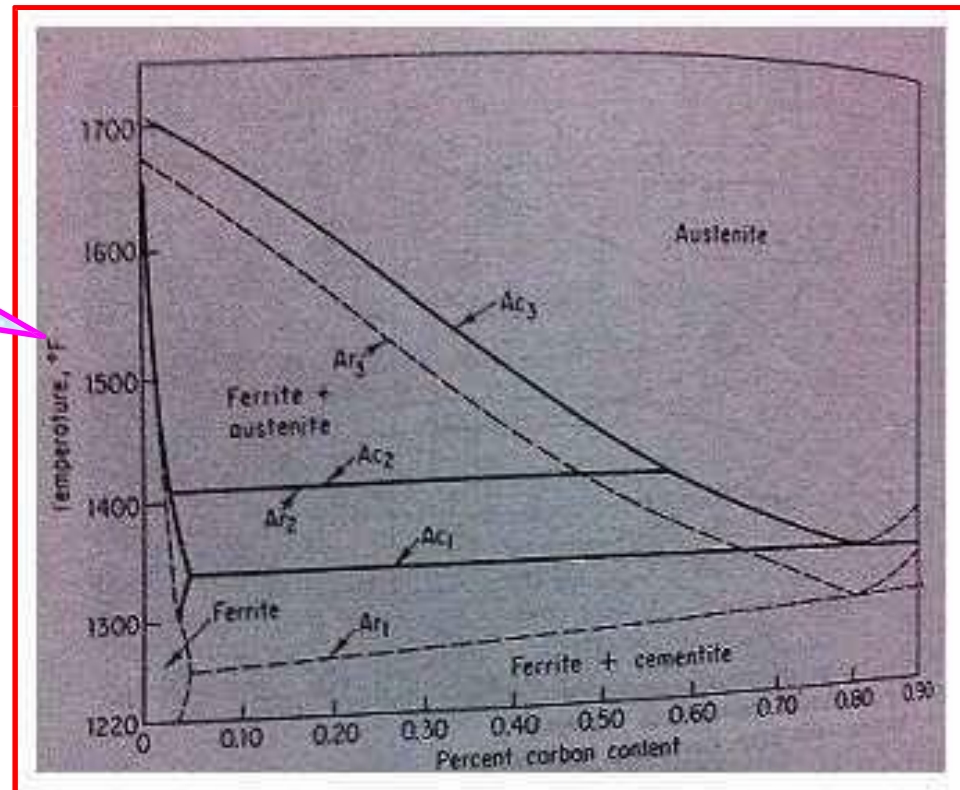

Effect of alloying elements on Fe-Fe C phase diagram

Based on stabilizing Austenite

- ❑ Mn, Ni, Co, Cu, Zn increase the range in which γ -phase, or austenite is stable [by raising A_4 and lowering A_3 temperature and also tend to retard the separation of carbides.
- ❑ These elements have γ -phase FCC crystal structure (or similar structure) in which these elements are more soluble than ferrite, and that is why, in the $(\alpha+\gamma)$ two phase equilibrium, these segregate in austenite in preference to ferrite.
- ❑ Elements like carbon and nitrogen (interstitial solid solution forming elements) are also austenite stabilizers.

Based on stabilizing Ferrite

- ❑ Cr, W, Mo, V, Si, Al, Be, Nb, P, Sn, Ti, Zr increase the range of α -phase (by lowering A_4 and raising A_3 temperatures).
- ❑ These elements have α phase BCC crystal structure (or similar structure) and thus in $(\alpha+\gamma)$ two phase equilibrium, these elements segregate in ferrite in preference to austenite. These elements decrease the amount of carbon soluble in austenite, and thus tend to increase the volume of the free carbide in the steel for a given carbide content.
- ❑ Chromium is a special case of these elements as at low concentrations, chromium lowers A_3 temperature and raises A_4 , but at high concentrations raises A_3 temperature. Overall, the stability of austenite is continuously decreased.

Effect of alloying elements on Austenite phase region Mn, Cr

- Mn is Austenite stabilizer
- Expansion of γ phase field with \uparrow Mn

Outline of the γ phase field

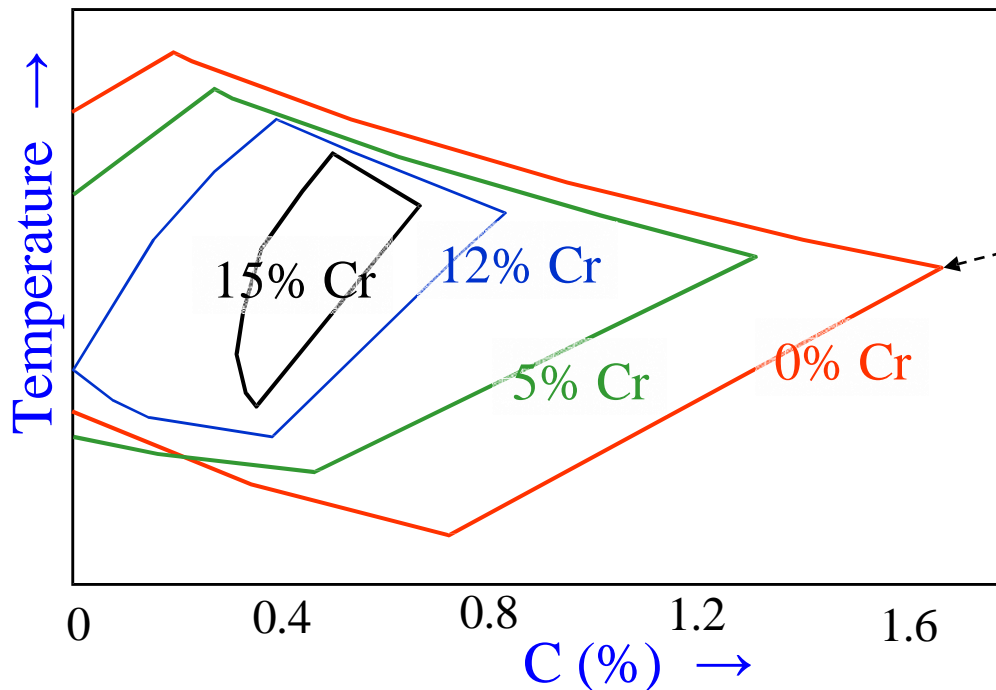
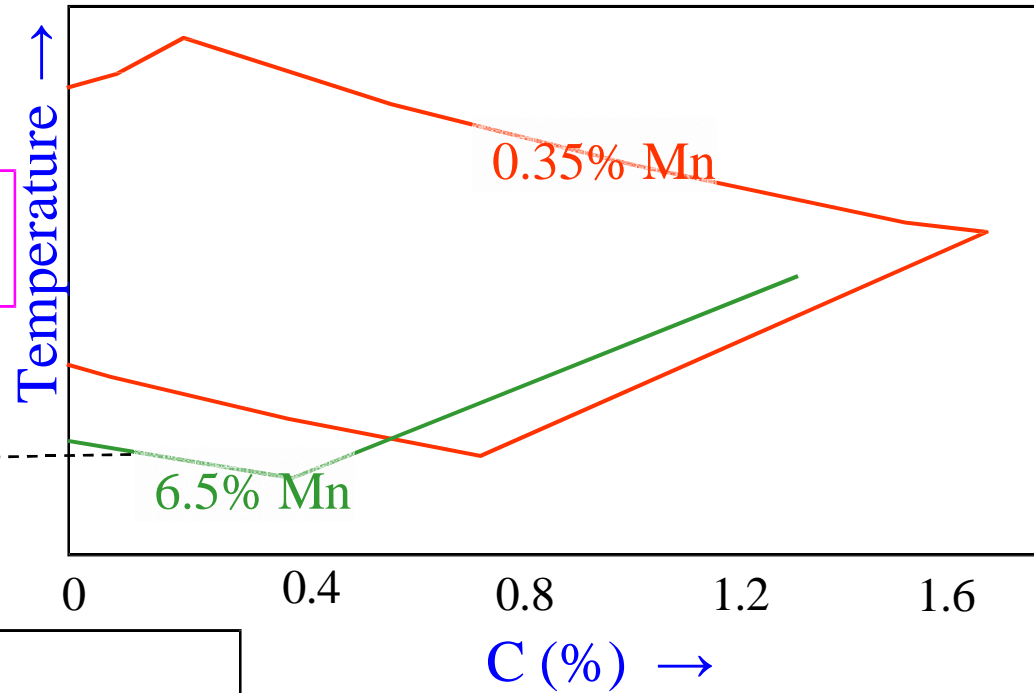

Outline of the γ phase field

- Cr is Ferrite stabilizer
- Shrinking γ phase field with \uparrow Cr

Effect of alloying elements on Fe-Fe | C phase diagram

Carbide forming elements

- ❑ Important elements, in this class, are arranged in order of increasing affinity for carbon, and thus the carbide forming potential of the element :

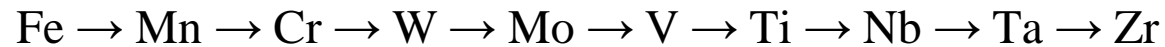

- ❑ For example, vanadium is added in steel having chromium and molybdenum with insufficient carbon, then vanadium first removes carbon from chromium carbide, the remaining vanadium then removes carbon from molybdenum carbide and forms its own carbide. The released Cr and Mo dissolve to form solid solution in austenite.

Graphitising elements

- ❑ Si, Ni, Cu, Al are common graphitizers. Small amount of these elements in steel can graphitise it and thus, impair the properties of steel unless elements of austenite stabilizers are present to counteract the effect.

Neutral element

- ❑ Co is the only element which neither forms carbide, nor causes graphitisation.

Effect of alloying elements on Fe-Fe₃C phase diagram

Effect on Eutectoid composition

- ❑ All the elements lower the eutectoid carbon content. Titanium and molybdenum are the most effective in lowering it.
- ❑ For example, a steel with 5% Cr has its eutectoid point at 0.5%C as compared to 0.8% in carbon steels. High speed steel has eutectoid point at 0.25% carbon.

Effect on Eutectoid temperature

- ❑ Elements like Ni, Mn i.e., the austenite stabilizers lower the eutectoid temperature (727°C). Ferrite stabilizers like Cr, V, W etc. raise the eutectoid temperature.

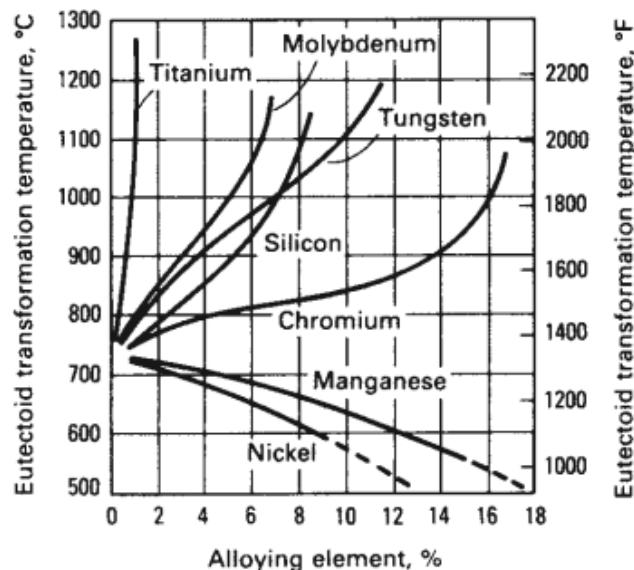

Effect of alloying element on eutectoid temperature

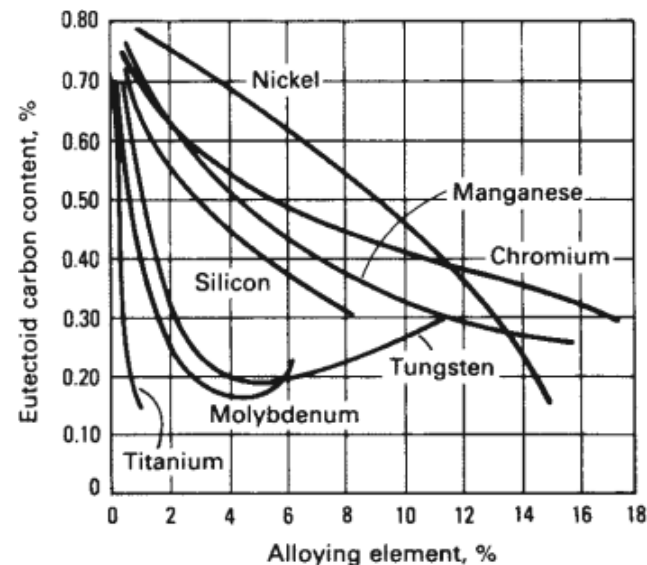

Effect of alloying element on effective carbon content

Limitations on Fe-Fe₃C phase diagram

- ❑ Fe-Fe₃C diagram represents behavior of steels under equilibrium conditions, whereas the actual heat treatments of steels are normally under non-equilibrium conditions.
- ❑ The diagram does not indicate the character of transformation of austenite such as to bainite, or martensite.
- ❑ The diagram does not indicate the presence of metastable phases like martensite, or bainite.
- ❑ It does not indicate the temperature of start of martensite M_s or bainite B_s .
- ❑ It does not indicate the kinetics of the transformation of austenite to martensite, bainite or even pearlite.
- ❑ It does not indicate the possibilities of suppressing the pearlitic or bainitic transformations.

Strengthening Mechanisms in Steels

Solid Solution Strengthening

- ❑ Solid solution strengthening is a phenomenon that occurs when the number of impurity atoms in the lattice of the basic element is so small that they are incapable of forming both stable and metastable precipitation phases under any thermal treatment conditions.
- ❑ Consider the influence of carbon, which is statistically uniformly distributed in the lattice of the α -iron, on the structure and properties of α -iron. Solubility of carbon in α -iron is much lower than in the γ -iron. It forms interstitial solid solutions with both irons.
- ❑ However, whereas the γ -iron lattice has sufficiently large pores for implantation of carbon atoms, the cubic lattice of the α -iron suffers, upon introduction of carbon atoms, a tetragonal distortion similar to the one of the martensite lattice, except that in the former case the distortion is much smaller.
- ❑ In addition, implantation of carbon atoms causes the entire lattice of the α -iron to expand somewhat. For example, at a carbon content of 0.015% the lattice constant increases at room temperature by 0.025c.
- ❑ The yield stress rises most dramatically with an increase in the carbon concentration from 10^{-7} to 10^{-4} - 10^{-3} %. The influence that carbon exerts on plastic deformation resistance of the α -phase is due to both its strong interaction with dislocations and pinning of the dislocations and elastic deformations arising as a result of the tetragonal distortion of the α -phase lattice after implantation of carbon atoms.
- ❑ Dissolution of part of the carbon in the α -phase and suggests that the solid solution strengthening of the phases is one of the factors providing the high strength properties of intermediate transformation products.

Strengthening mechanisms in steels

Grain Size Refinement

- ❑ Austenite passes to other phases during cooling, its grain size represents an important characteristic of steel. This is due to the fact that all structural components are formed within each separate crystal.
- ❑ The smaller the austenite grains, the finer the network of excess ferrite at their boundaries and the smaller the pearlite colonies and martensite crystals. Therefore, a fine grain corresponds to a fine crystal fracture of steel and vice versa at the temperatures where austenite has already precipitated.
- ❑ Impact strength is especially sensitive to the austenite grain size, and it decreases with grain enlargement. A decrease in the dimensions of pearlite colonies inside the initial austenite grain favors a rise in impact strength also.
- ❑ Although the grain size has a considerable effect on impact strength, its influence is small if any on the statistical characteristics of mechanical properties such as hardness, fracture stress, yield stress, and specific elongation. Only the actual grain size affects steel properties, the inherited size has no effect.
- ❑ However, the technological process of heat treatment is determined by the inherited grain. For example, a hereditarily fine-grained steel may be deformed at a higher temperature with the assurance that the coarse-grained structure will not occur.

Strengthening mechanisms in steels

Dispersion strengthening

- ❑ In the majority of metal alloys, precipitation of supersaturated solid solutions formed during quenching is followed by precipitation of disperse particles enriched in atoms of the alloying components. It was found that the strength (hardness) of the alloys increases with the precipitation of these particles. The increment in the value of these characteristics increases as the dispersion and volume fraction of the particles increase. This phenomenon has been referred to as dispersion strengthening.
- ❑ When a solid solution of carbon in α -iron is cooled below point A_1 , carbon should precipitate as cementite with lowering of the carbon solubility and a decrease in temperature. This process is realized under sufficiently slow cooling, which is accompanied by diffusion processes, leading to the formation of cementite.
- ❑ In the case of abrupt cooling, e.g., water quenching, carbon has no time to precipitate. A supersaturated solid solution appears. At room temperature the retained amount of carbon can correspond to its maximum solubility of 0.018%. During subsequent storage at room temperature (natural aging) carbon tends to precipitate from the solid solution. Carbon-enriched regions appear predominantly in defective sections of the matrix. Precipitation of carbon from a supersaturated solid solution during natural aging results in improvement of its strength characteristics and hardness. However, plastic characteristics—reduction of area, specific elongation, and impact strength are impaired. A clearly pronounced yield stress appears after a long natural aging. Hardness may increase by 50% over that of a quenched state. The phenomenon of dispersion strengthening is observed.

Strengthening mechanisms in steels

Work Hardening

- ❑ An important method used to strengthen steels is deformation strengthening. Strengthening achieved with crystal deformation can be judged from the shape of stress–strain curves.
- ❑ The actual shape of these curves largely depends on the crystal lattice type of the metal, its purity, and thermal treatment.
- ❑ In the case of cubic lattice metals, strengthening curves are parabolic, whereas for hexagonal lattice metals a nearly linear dependence is observed between the stress and the strain.
- ❑ This fact suggests that plastic deformation strengthening is determined mainly by the interaction of dislocations and is associated with the structural changes that impede the movement of dislocations.
- ❑ Metals with a hexagonal lattice are less prone to deformation strengthening than cubic lattice metals because the hexagonal lattice has fewer easy slip systems.
- ❑ In cubic lattice metals, the slip proceeds in several intersecting planes and directions.

Classification

HEAT TREATMENT

BULK

SURFACE

Annealing

Tempering

Normalizing

Hardening

Thermal

Thermo-Chemical

Full Annealing

Flame

Carburizing

Recrystallization Annealing

Induction

Nitriding

Stress Relief Annealing

Laser

Cyaniding

Spheroidization Annealing

Electron Beam

Boronizing

Diffusion Annealing

Chromizing

Partial Annealing

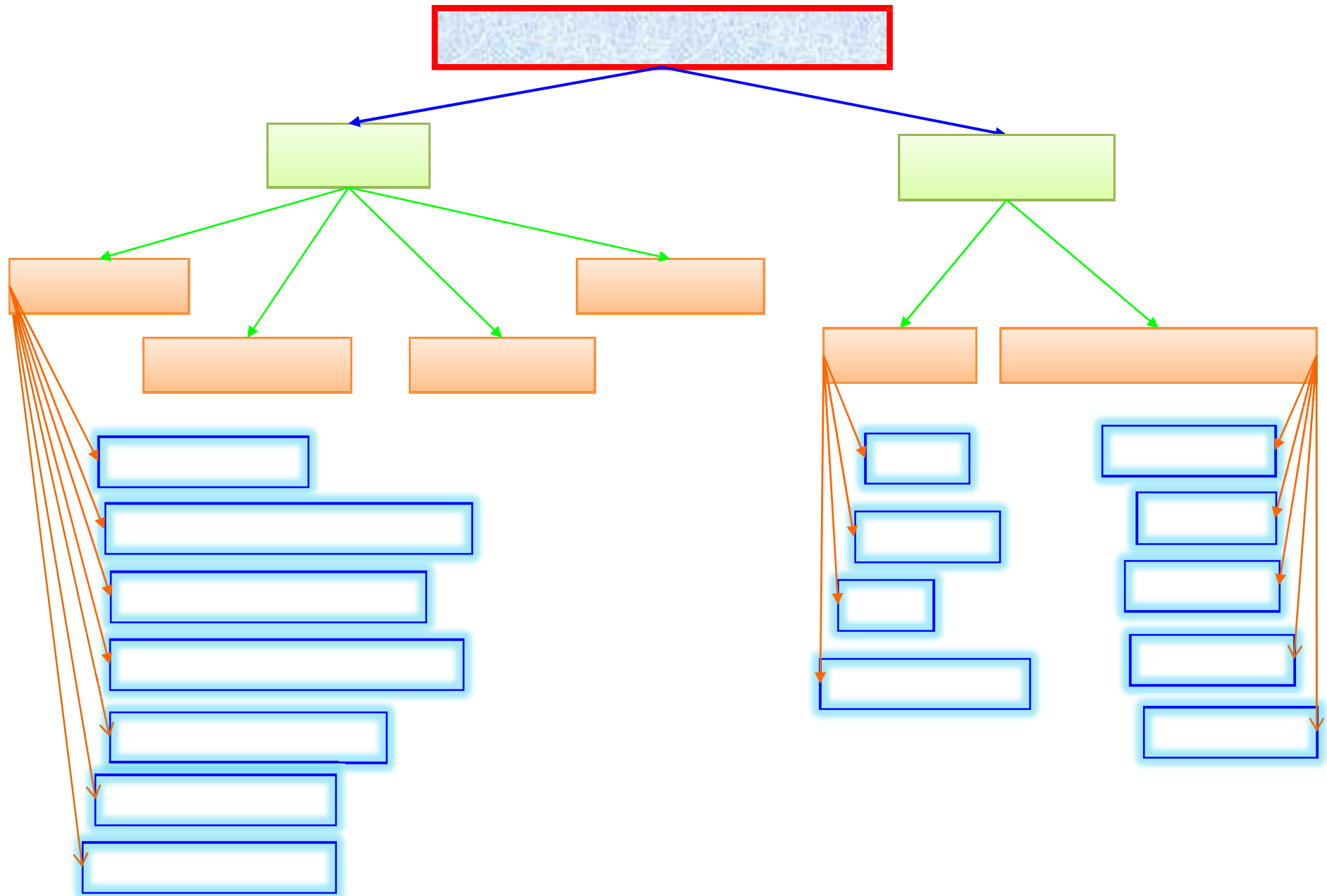

Annealing

Full Annealing

- ❑ The steel is heated above A_3 (for hypo-eutectoid steels) | A_1 (for hyper-eutectoid steels) →(hold) →then the steel is furnace cooled to obtain Coarse Pearlite
- ❑ Coarse Pearlite has ↓ Hardness, ↑ Ductility
- ❑ Not above A_{cm} →to avoid a continuous network of proeutectoid cementite along grain boundaries (→path for crack propagation)

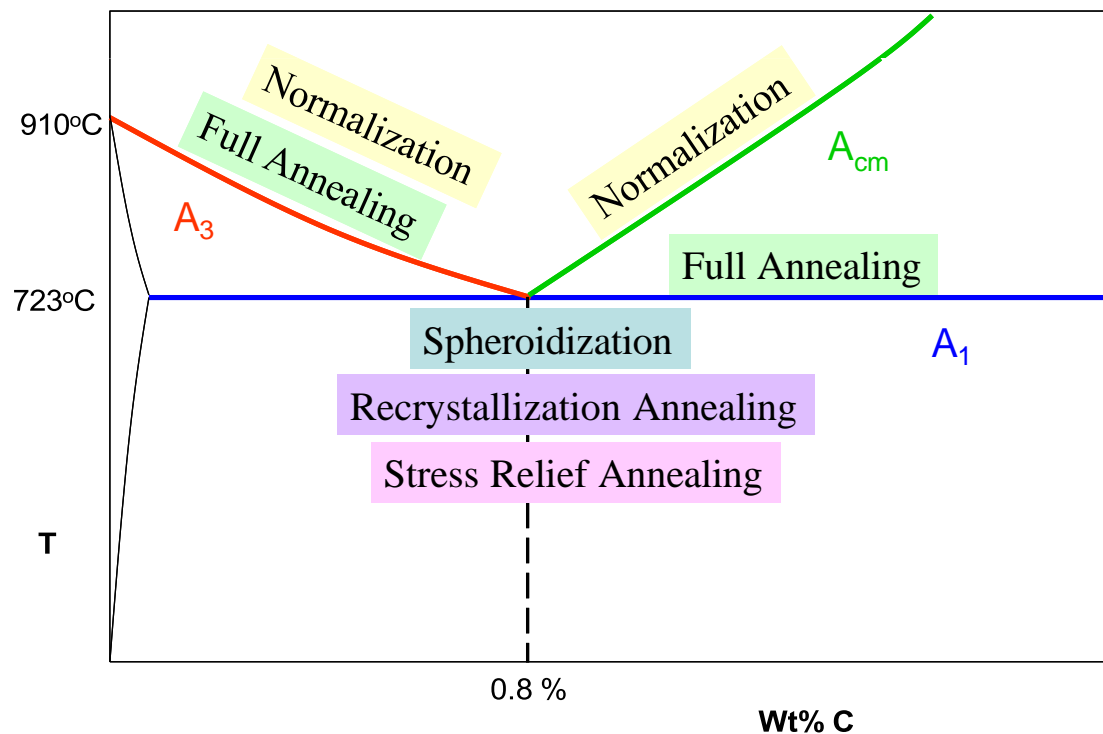

Annealing

Recrystallization Annealing

❑ The Heat below A_1 → Sufficient time → Recrystallization

Cold worked grains → New stress free grains

❑ Used in between processing steps (e.g. Sheet Rolling)

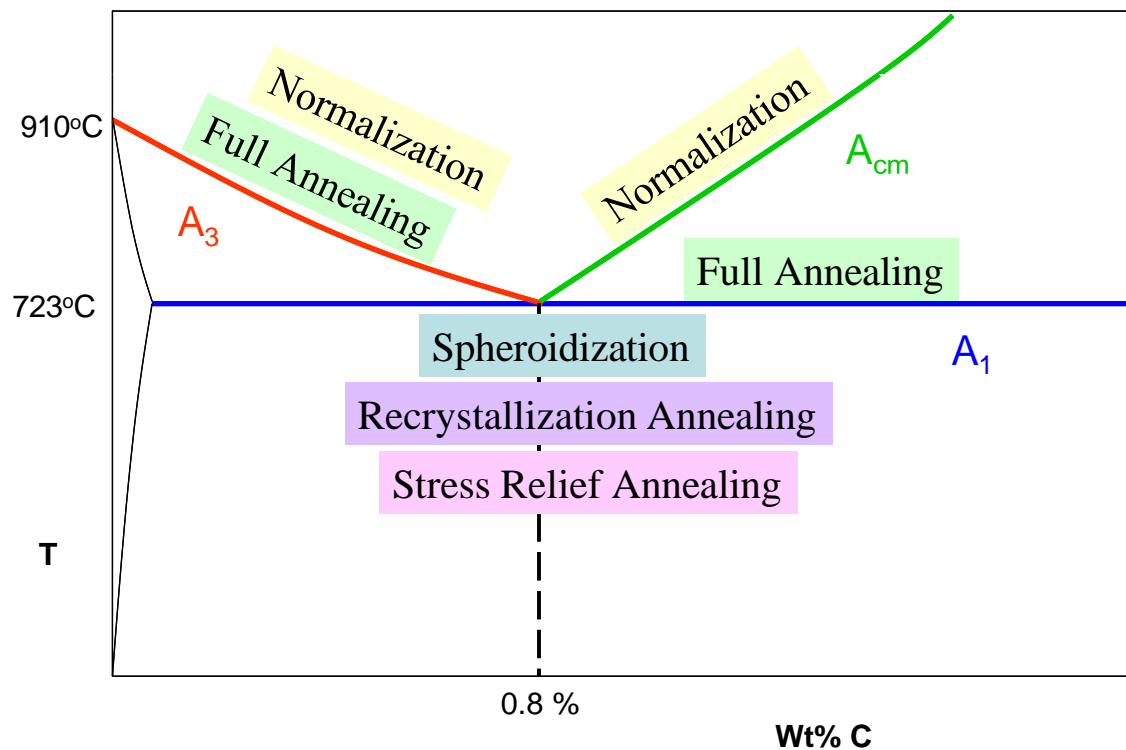

Annealing

Stress Relief Annealing

Residual stresses → Heat below A_1 → **Recovery**

- Differential cooling
- Martensite formation
- Machining and cold working
- Welding

Annihilation of dislocations,
polygonization

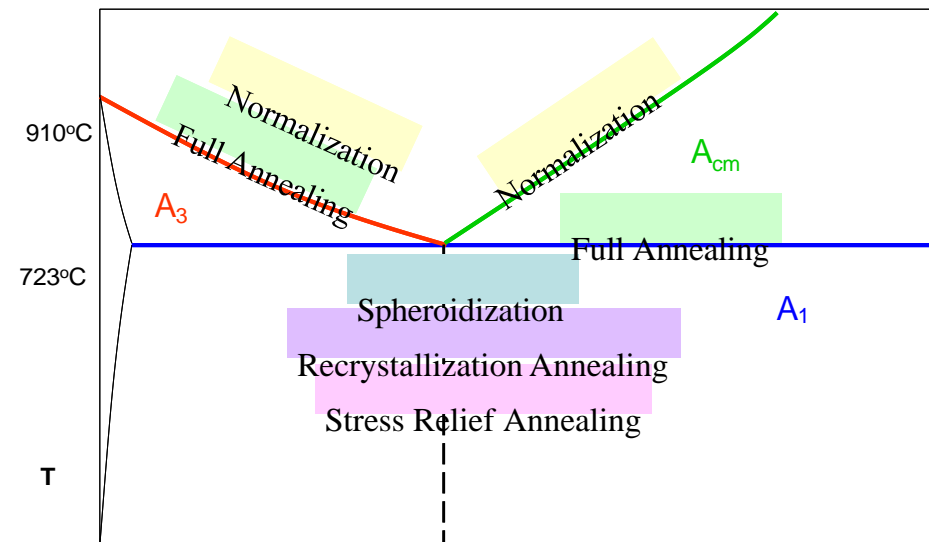

0.8 %

Wt% C

Annealing

Spheroidization Annealing

Heat below/above A_1 (Prolonged holding*)
Cementite plates \rightarrow Cementite spheroids \rightarrow \uparrow Ductility

- Used in high carbon steel requiring extensive machining prior to final hardening and tempering*
 - Driving force is the reduction in interfacial energy*
-
- The spheroidized structure is desirable when minimum hardness, maximum ductility, or (in high-carbon steels) maximum machinability is important.
 - Low-carbon steels are seldom spheroidized for machining, because in the spheroidized condition they are excessively soft and “gummy”.
 - Medium-carbon steels are sometimes spheroidization annealed to obtain maximum ductility.

**If the steel is kept too long at the spheroidized-annealing temperature, the cementite particles will coalesce and become elongated thus reducing machinability*

Annealing

Diffusion Annealing

- ❑ This process also known as homogenizing annealing, is employed to remove any structural non-uniformity.
- ❑ Dendrites, columnar grains and chemical inhomogeneities are generally observed in the case of ingots, heavy plain carbon steel casting, and high alloy steel castings. These defects promote brittleness and reduce ductility and toughness of steel.
- ❑ In diffusion annealing treatment, steel is heated sufficiently above the upper critical temperature (say, 1000-1200°C), and is held at this temperature for prolonged periods, usually 10-20 hours, followed by slow cooling.
- ❑ Segregated zones are eliminated and a chemically homogeneous coarse grain steel is obtained by this treatment as a result of diffusion.
- ❑ The coarse grained structure can be refined either by plastic working for ingots or by employing a second heat treatment for castings.
- ❑ Hypoeutectoid and eutectoid steel castings are given full annealing treatment, whereas hypereutectoid steel castings are either normalized or partially annealed for this purpose.

Annealing

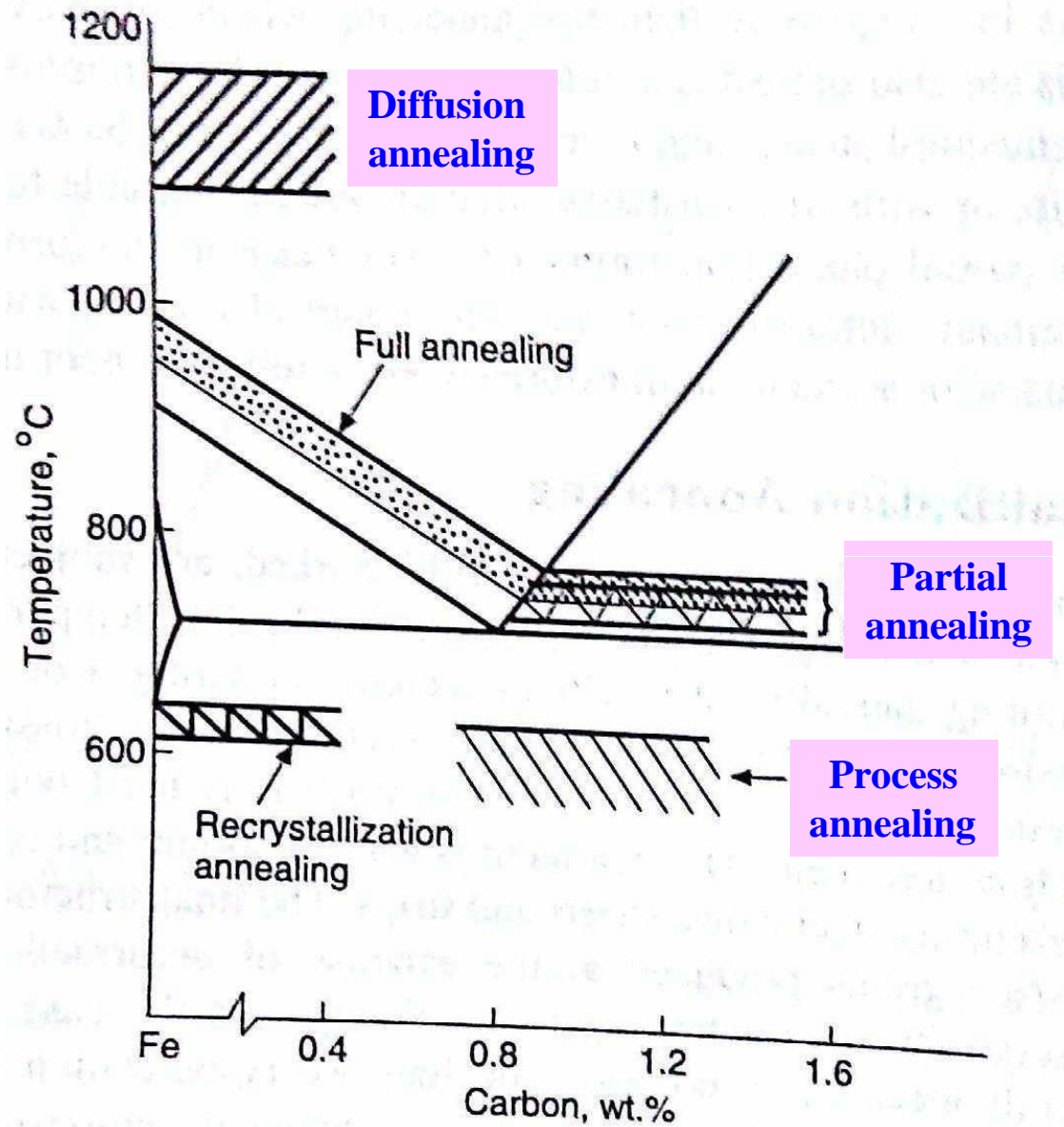

Temperature ranges for various types of annealing processes

Annealing

Partial Annealing

- ❑ Partial annealing is also referred to as intercritical annealing or incomplete annealing. In this process, steel is heated between the A_1 and the A_3 or A_{cm} . It is followed by slow cooling.
- ❑ Generally, hypereutectoid steels are subjected to this treatment. Resultant microstructure consists of fine pearlite and cementite. The reason for this is that grain refinement takes place at a temperature of about 10 to 30°C above A_{c1} for hypereutectoid steels.
- ❑ As low temperature are involved in this process, so it is cost effective than full annealing

Process Annealing

- ❑ In this treatment steel is heated to a temperature below the lower critical temperature, and is held at this temperature for sufficient time and then cooled. Since it is a subcritical annealing, cooling rate is of little importance
- ❑ The purpose of this treatment is to reduce hardness and to increase ductility of cold-worked steel so that further working may be carried out easily. It is an Intermediate operation and is sometimes referred to as in process annealing. The process is less expensive than Recrystallization annealing.

Normalizing

Heat above A_3 | A_{cm} → Austenization → Air cooling → Fine Pearlite (Higher hardness)

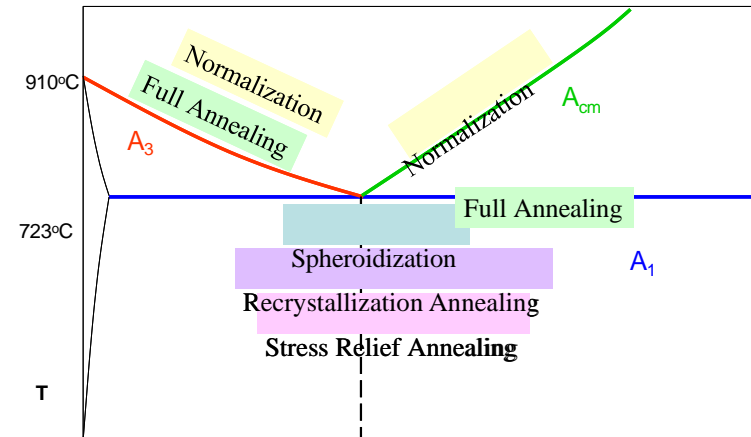
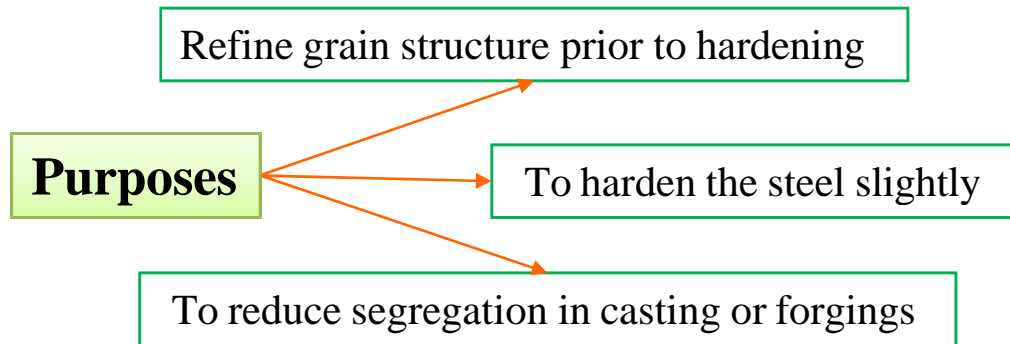

- ❑ In hypo-eutectoid steels normalizing is done 50°C above the annealing temperature
- ❑ In hyper-eutectoid steels normalizing done above A_{cm} → due to faster cooling cementite does not form a continuous film along GB

Annealed Vs Normalized

Annealed	Normalized
Less hardness, tensile strength and toughness	Slightly more hardness, tensile strength and toughness
Pearlite is coarse and usually gets resolved by the optical microscope	Pearlite is fine and usually appears unresolved with optical microscope
Grain size distribution is more uniform	Grain size distribution is slightly less uniform
Internal stresses are least	Internal stresses are slightly more

Hardening

Heat above A_3 | A_{cm} → Austenization → Quench (higher than critical cooling rate)

- ❑ Certain applications demand high tensile strength and hardness values so that the components may be successfully used for heavy duty purposes. High tensile strength and hardness values can be obtained by a processes known as **Hardening**.
- ❑ hardening process consists of four steps. The first step involves heating the steel to above A_3 temperature for hypoeutectoid steels and above A_1 temperature for hypereutectoid steels by 50°C .
- ❑ The second step involves holding the steel components for sufficient soaking time for homogeneous austenization.
- ❑ The third step involves cooling of hot steel components at a rate just exceeding the critical cooling rate of the steel to room temperature or below room temperature.
- ❑ The final step involves the tempering of the martensite to achieve the desired hardness. Detailed explanation about tempering is given in the subsequent sections. In this hardening process, the austenite transforms to martensite. This martensite structure improves the hardness.
- ❑ In the hardening process, which involves quenching and tempering. During quenching the surface is cooled quicker than the center. In other words the transformation of the austenite is proceeding at different rates. Hence there is a limit to the overall size of the part in this hardening process.

Hardening

A few salient features in hardening of steel

- ❑ Proper quenching medium should be used such that the component gets cooled at a rate just exceeding the critical cooling rate of that steel.
- ❑ Alloy steels have less critical cooling rate and hence some of the alloy steels can be hardened by simple air cooling.
- ❑ High carbon steels have slightly more critical cooling rate and has to be hardened by oil quenching.
- ❑ Medium carbon steels have still higher critical cooling rates and hence water or brine quenching is necessary.

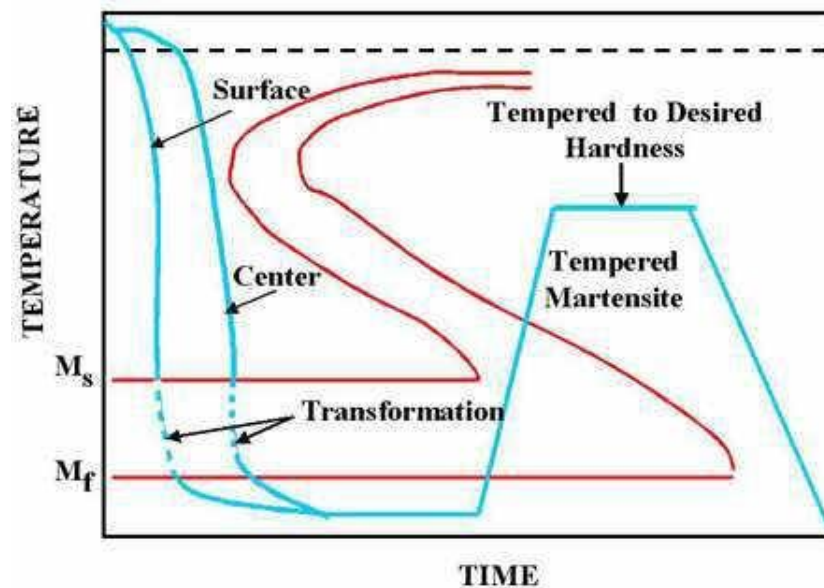

Hardening

Factors affecting Hardening Processes

- Chemical composition of steel
- Size and shape of the steel part
- Hardening cycle (heating/cooling rate, temp, soak time)
- Homogeneity and grain size of austenite
- Quenching media
- Surface condition of steel part

Hardening Methods

- Conventional or direct quenching
- Quenching in stages in sequence in different media
- Spray Quenching
- Quenching with self tempering
- Austempering or Isothermal Quenching
- Martempering

Retained Austenite

- ❑ Austenite that is present in the ferrous alloys even after the completion of the heat treatment process is referred to as retained austenite. In simple words, retained austenite is the untransformed austenite.
- ❑ Austenite transforms to martensite between M_s and M_f temperatures as it is essentially an athermal transformation. However, this transformation never goes to completion, i.e., 100% martensite (M_f temperature line is illustrated as dotted line in TTT diagrams).
- ❑ This is because at M_f , a small amount of (~1%) of austenite is present in highly stressed state along with ~99% martensite, and can not transform to martensite because unfavourable stress conditions.
- ❑ Both M_s and M_f temperatures decrease with increase in carbon content. Therefore amount of retained austenite in hardened steels increase with increase in carbon content.
- ❑ All alloying elements, except Al and Co, lower the M_s temperature and hence enhance the amount of retained austenite. Therefore, both high carbon steels and high alloy steels are more prone to the presence of retained austenite.
- ❑ The substructure of retained austenite differs from that of the original austenite as it has a higher density of imperfections like dislocations, stacking faults, etc. which are created by local plastic deformation of the austenite by martensite crystals.
- ❑ Tool steels may have retained- austenite in the range of 5-35%. At the surface of a ~~quenched~~ steel, that restrains are minimum. R.A is less at surface than center of the part.

Retained Austenite

Advantages

- ❑ Ductility of austenite can help to relieve some internal stresses developed due to hardening, to reduce danger of distortion and cracks. 10% retained austenite along with martensite is desirable.
- ❑ The presence of 30-40% retained austenite makes straightening operation of the components possible after hardening. Straightening increases the hardness slightly.
- ❑ Non-distorting steels owe their existence to retained austenite. Here enough austenite is retained to balance the transformational contracting during heating, on the formation of austenite from ferrite carbide aggregate on the one hand, and the expansion corresponding to the formation of martensite during cooling, on the other, Here, the basis of dimensional stability of non-distorting steels is the presence of retained austenite.

disadvantages

- ❑ The soft austenite if present, in large amounts, decreases the hardness of hardened steels.
- ❑ As retained austenite may transform to lower bainite, or to martensite, there takes place increase in dimensions of the part. Not only it creates problems in precision gauges, or dies, the neighboring parts may be put under stress by it. In the component itself, stresses may be created to cause distortion or cracking.
- ❑ Retained austenite decreases the magnetic properties of the steel.

Sub-Zero treatment

- ❑ The retained austenite is generally undesirable, sub-zero treatment is one of the methods to eliminate retained austenite.
- ❑ As the room temperature lies between M_s and M_f temperatures of steel, quenching to room temperature results in retained austenite.
- ❑ Subzero treatment consists in cooling the hardened steel to a temperature below 0°C . The temperature of the sub zero treatment depends on the position of M_f temperature of the steel.
- ❑ A steel can be cooled much below the M_f temperature, but it, evidently achieves nothing, because it cannot bring about any additional increase of hardness, or any additional increase of martensite, because the Martensitic transformation ends at M_f temperature.
- ❑ Sub-zero treatment is more effective, if it is carried out immediately after quenching operation. Any lapse of time between hardening and the cold treatment causes the stabilization of austenite, makes the retained austenite resistant to further transformation.
- ❑ Most steels can be cooled by subzero treatment in a low cooling unit with one of the mediums as given in table (next page) .
- ❑ The low-cooling unit consists of two vessels, the interior one of copper, where the parts or tools to be deep frozen, are placed and the exterior one of steel provided with a good heat insulation.

Sub-Zero treatment

Table : Subzero Coolants with Temperature of Application

Coolant	Minimum temperature °C
Dry ice (solid CO_2) + Acetone	-78
Ice + Salt (NaCl)	-23
Ice + Salt (CaCl_2)	-55
Liquid air	-183
Liquid Nitrogen	-196
Liquid Pentane	-129
Freon	-111

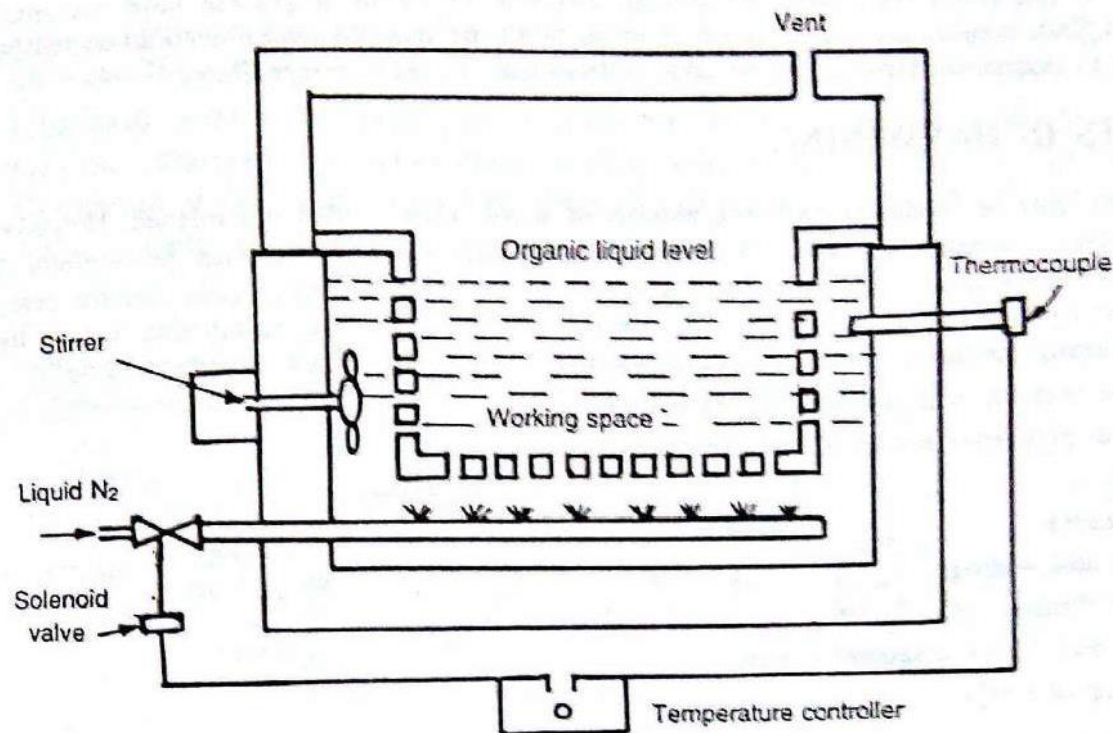

Figure : Liquid cooled (liquid N_2) system. Components are immersed in a bath of alcohol, or trichloro ethylene, which is cooled by a submerged liquid nitrogen spray (-150°C), cooling rates can be controlled.

Sub-Zero treatment

- ❑ The space in between the vessels is filled with one of the chosen medium, or a system (figure in previous page) which is inexpensive and can be used.
- ❑ Usually the temperature range used is in range of -30°C to -150°C , and total time of cooling and holding at that temperature (M_f) varies from $\frac{1}{2}$ - 1 hour. The hardness increased by 2-4 HRc.
- ❑ As the amount of martensite increases by sub-zero treatment, it increases hardness, abrasion resistance, fatigue resistance and eliminates the danger of developing grinding cracks.
- ❑ As the newly formed martensite may add further to unfavorable stresses to cause distortion and cracks, the complicated, or intricate shaped components may be first tempered at 150 - 160°C immediately after first quenching and then given the sub-zero treatment.

Sub-zero treatment has been most extensively used for...!

- ❑ Alloyed tool steels – like high speed steel, which now shall need only single stage tempering.
- ❑ Tools and components which need exact dimensions – gauges
- ❑ Carburized steels, especially alloy steels (having elements like Ni in it) to increase their hardness and wear resistance
- ❑ Steels having 0.8 to 1.1% C as hardness increases by 1-3 HRc

Tempering

- ❑ The hardened steel is not readily suitable for engineering applications. It possesses following three drawbacks.
 - ✓ Martensite obtained after hardening is extremely brittle and will result in failure of engineering components by cracking.
 - ✓ Formation of martensite from austenite by quenching produces high internal stresses in the hardened steel.

- ✓ Structures obtained after hardening consists of martensite and retained austenite. Both these phases are metastable and will change to stable phases with time which subsequently results in change in dimensions and properties of the steel in service.

- ❑ Tempering helps in reduce these problems. Tempering is the process of heating the hardened steel to a temperature maximum up to lower critical temperature (A_1), soaking at this temperature, and then cooling, normally very slowly.

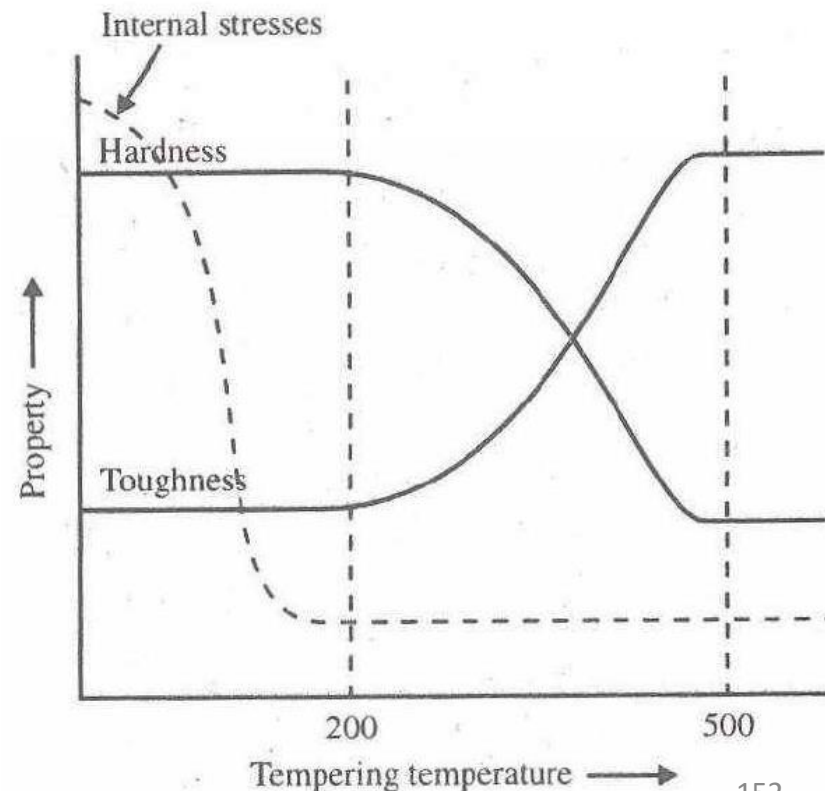

Variation in properties with tempering temperature

Tempering

Objective

Relieve Internal stresses

Restore ductility and toughness

To improve dimensional stability

To improve magnetic properties

Structure in as Quenched state

Highly supersaturated martensite

Retained austenite

Undissolved carbides

Rods, or plates of carbide particles produced during 'auto-tempering'

Segregation of carbon

Tempering of plain carbon steels

First stage of Tempering

- ❑ First Stage of tempering temperature extends from room temperature to 200°C. The tempering reactions in steels, containing carbon less than 0.2%, differ somewhat from the steels containing more than 0.2% carbon.
- ❑ In the former, if carbon atoms have not yet segregated (during quenching) to dislocations, these diffuse and segregate around the dislocations and lath boundaries in the first stage of tempering. No ϵ -carbide forms as all the carbon gets locked up to the dislocations (defects).
- ❑ Martensite in steels with more than 0.2% carbon is highly unstable because of super saturation, and interstitial diffusion of carbon in BC martensite can occur. Thus in the first stage of tempering, the decomposition of martensite into low-tetragonality martensite (containing $\sim 0.2\%C$, $c/a \sim 1.014$) and ϵ -carbide, $Fe_{2.4}C$ occurs. (*There are reports of precipitation of eta-carbide, Fe_2C and Hagg's carbide, $Fe_{2.2}C$.*)
- ❑ ϵ -carbide is a separate phase and is not a preliminary step in the formation of cementite, but it nucleates and grows more rapidly than cementite. It has HCP structure with $c = 4.33A^\circ$, $a = 2.73A^\circ$, $c/a = 1.58A^\circ$ and forms as small (0.015-0.02 μm) platelets, or needles observed under electron microscope.
- ❑ The structure at this stage referred to as tempered martensite, which is double phase mixture of low tetragonal martensite and ϵ -carbide.
- ❑ In this stage volume \downarrow because specific volume of martensite \downarrow due to rejecting of C atoms.

Tempering of plain carbon steels

Second stage of Tempering

- ❑ Second Stage of tempering temperature lies between 200-300°C. The amount of retained austenite in the as-quenched steel depends mainly on the composition of the steel, and the temperature to which steel is quenched.
- ❑ In the second stage of tempering retained austenite transforms to lower bainite (the carbide in bainite is ϵ -carbide). The matrix in lower bainite is cubic ferrite ($c/a = 1$), whereas in tempered martensite, the low tetragonal martensite has $c/a \sim 1.014$
- ❑ When retained austenite changes to lower bainite, there takes place an increase in volume.

Third stage of Tempering

- ❑ Third Stage of tempering temperature lies between 200-350°C. In this stage of tempering, ϵ -carbide dissolves in matrix, and low tetragonal martensite loses its completely its carbon and thus, the tetragonality to become ferrite .
- ❑ Cementite forms as rods at interfaces of ϵ -carbide and matrix, twin boundaries, interlath boundaries, or original austenite grain boundaries.
- ❑ During this stage, volume decreases just as in stage one, due to complete loss of tetragonality. In a 1% carbon steel , the total decrease in length in the first and third stages is around 0.25%

Tempering of plain carbon steels

Fourth stage of Tempering

- ❑ Fourth Stage of tempering temperature lies between 350-700°C.
- ❑ Growth and spheroidisation of cementite, as well as recovery and Recrystallization of ferrite occur. Though the growth of cementite starts above 300°C, its spheroidisation starts above 400°C to 700°C.
- ❑ Spheroidisation takes place due to reduction in interfacial energy of ferrite-cementite interfaces. As quenched martensite has high concentration of lattice defects. Though their annealing out starts in the third stage of tempering, but the cementite precipitates retard the recovery processes.
- ❑ Substantial recovery processes starts occurring only above 400°C. original lath boundaries are stable up to 600°C, but above this, these are replaced by equiaxed-ferrite grain boundaries – the process, which is best described as ‘Recrystallization’.
- ❑ In the end, the optical microstructure consists of equiaxed ferrite grains with coarse Spheroidal particles of cementite, and then the structure is called globular pearlite, or spheroidized cementite.
- ❑ The structure perhaps is the most stable of all ferrite- cementite aggregates, and is the softest with highest ductility with best machinability.

Effect of carbon on Tempering

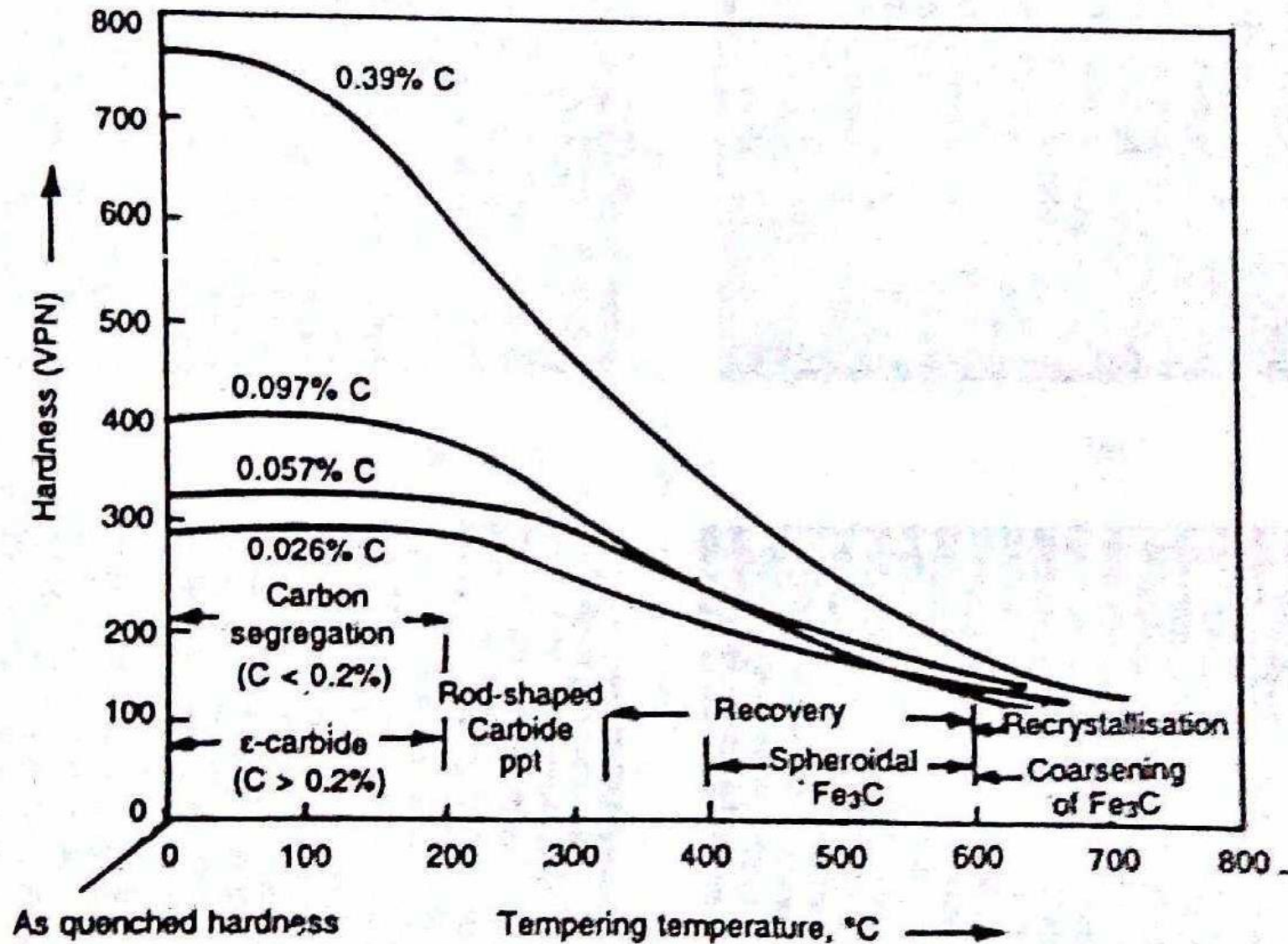

Effect of tempering temperature(1 hour at each temperature) on hardness and reactions

Tempering of alloy steels

- ❑ The presence of alloying elements, steels can change their nature and properties effectively.
- ❑ Most common elements (except cobalt) shift the CCT curve to longer times, which essentially result in the increase of hardenability of the steels, so that pearlitic transformation can be avoided easily to obtain Martensitic structure, even at a slower rate of cooling and in thicker parts.
- ❑ Alloying elements also lower M_s and M_f temperatures, increasing further the amount of retained austenite. The decomposition of retained austenite on tempering, plays quite a significant role on the properties of tempered steels, specially having high carbon and high alloying elements.
- ❑ Some elements, that are not found in carbides, but are present as solid solution in ferrite, are Al, Cu, Si, P, Ni, and Zr. Some elements arranged in order of increasing tendency to form carbides are Mn, Cr, W, Mo, V and Ti. These carbide forming elements retard most effectively the rate of softening during tempering of the steel.
- ❑ The first stage of tempering does not appear to be effected by the presence of the alloying elements. However, most of the alloying elements in steels tends to increase the hardness after tempering than a plain carbon steel with the same carbon content.
- ❑ At smaller concentration, they merely retard the tempering processes hence the softening, particularly at higher temperature ($> 500^\circ\text{C}$), where these elements have good diffusivity to take part in tempering reactions.

Tempering of alloy steels

- ❑ When alloy carbides are formed, the drop in hardness during tempering is not only retarded but is significantly increased. The steel is then said to secondary hardening.
- ❑ Thus, 0.5% chromium, or less than 0.5% Mo resists softening but secondary hardening is produced by either 12% chromium, or 2% Mo.. Stronger the carbide, the more potent is the secondary hardening.

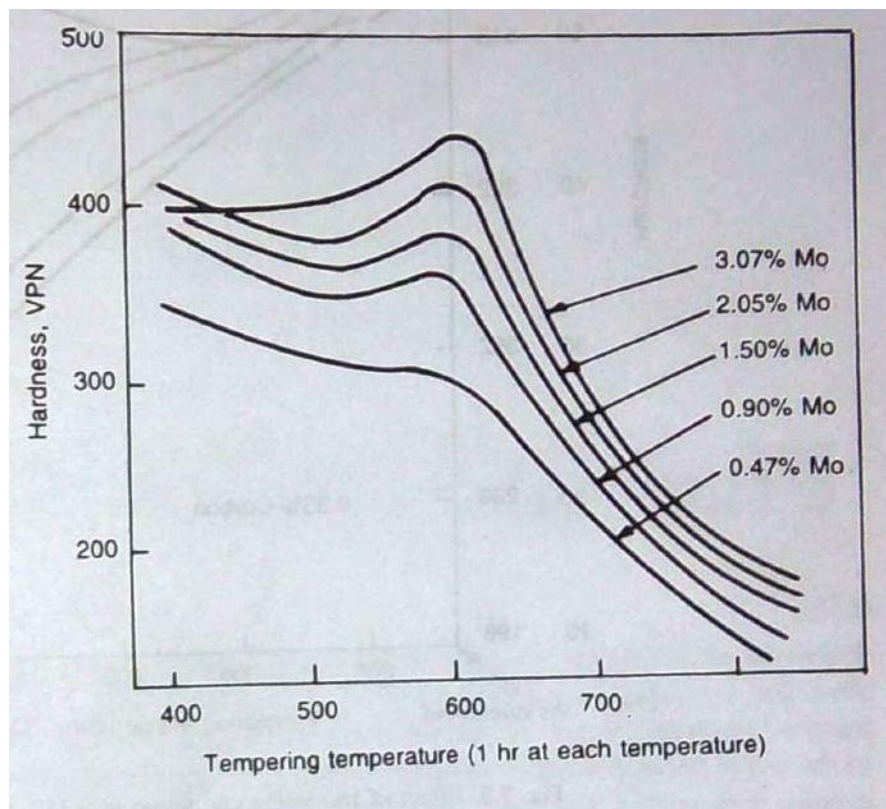

Effect of increasing Mo on tempering of as quenched 0.1% C steel

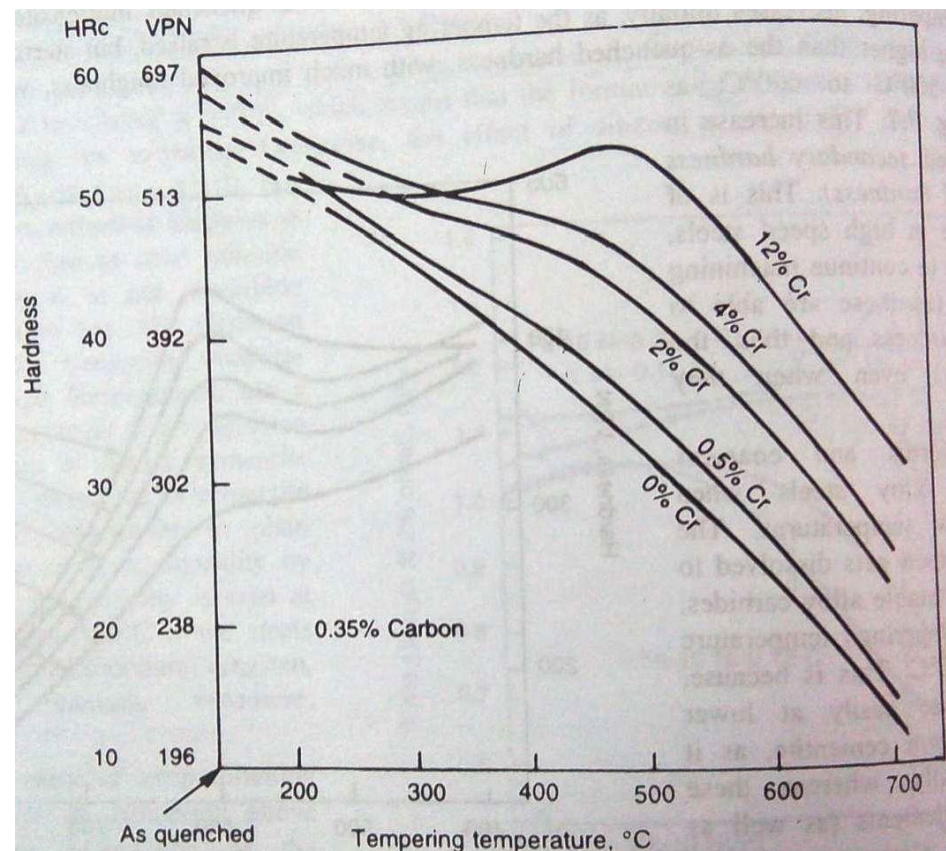

Effect of increasing chromium in 0.35% C steel on tempering

Tempering of alloy steels

- ❑ Element, such as, silicon dissolves in ϵ -carbide to stabilize it. Steels with 1-2% silicon have ϵ -carbide present even after tempering at 400°C, which means that the formation of cementite is delayed considerably, and thus, resisting the softening. Otherwise, the effect of silicon is essentially due to solid solution strengthening.
- ❑ Nickel has a small, but constant effect on tempered hardness at all temperatures due to solid solution strengthening as it is not a carbide former.
- ❑ Manganese has little effect on softening at low tempering temperatures, but at high temperatures, has a strong effect on due to its faster diffusion then, and thus, it resists cementite coarsening as it is present in cementite as $(\text{Fe, Mn})_3\text{C}$.
- ❑ Martensite in plain carbon steels losses its tetragonality by 300°C, but the tetragonality is seen at 450°C, or even at 500°C if the steels have elements like Cr, W, Mo, Ti, V and Si.
- ❑ The basic cause of steep softening in carbon steels on tempering above 400°C, is the coagulation of the cementite particles. Alloying elements notably Si, Cr, Mo, V, when present in steels, retard the coalescence and the coarsening of cementite particles., resulting in enhanced hardening over and above the solid solution hardening effect.
- ❑ Elements like Cr, Si, Mo, or W delay coarsening to temperature range of 500-550°C. up to tempering temperature 500°C, the carbides formed are of iron with proportional alloying elements in it, but above 500°C, alloying elements can form their own carbides and thus, coarse cementite particles are replaced by fine dispersion of more stable alloy carbides.

Tempering of alloy steels

- ❑ An Fe-10 Ni alloy shows constant hardness on tempering up to 450°C and then, there takes place some decrease in strength (curve I).
- ❑ Addition of 0.12% carbon increases the as quenched strength to almost double, and slow decrease of hardness occurs on tempering to fall to 0.7 GPa at 500°C.
- ❑ A 8% cobalt addition, which doesn't enter the carbide, delays the softening to have strength of 0.8 GPa at 500°C .
- ❑ Addition of 2% Cr almost continuously but slowly ↑ hardness to start falling at above ~450°C to become 1.1 GPa at 500°C by fine dispersion of Cr carbide.
- ❑ Addition of Mo causes secondary hardening, as it is very strong carbide forming element, to attain a hardness of 1.3 Gpa at 500°C

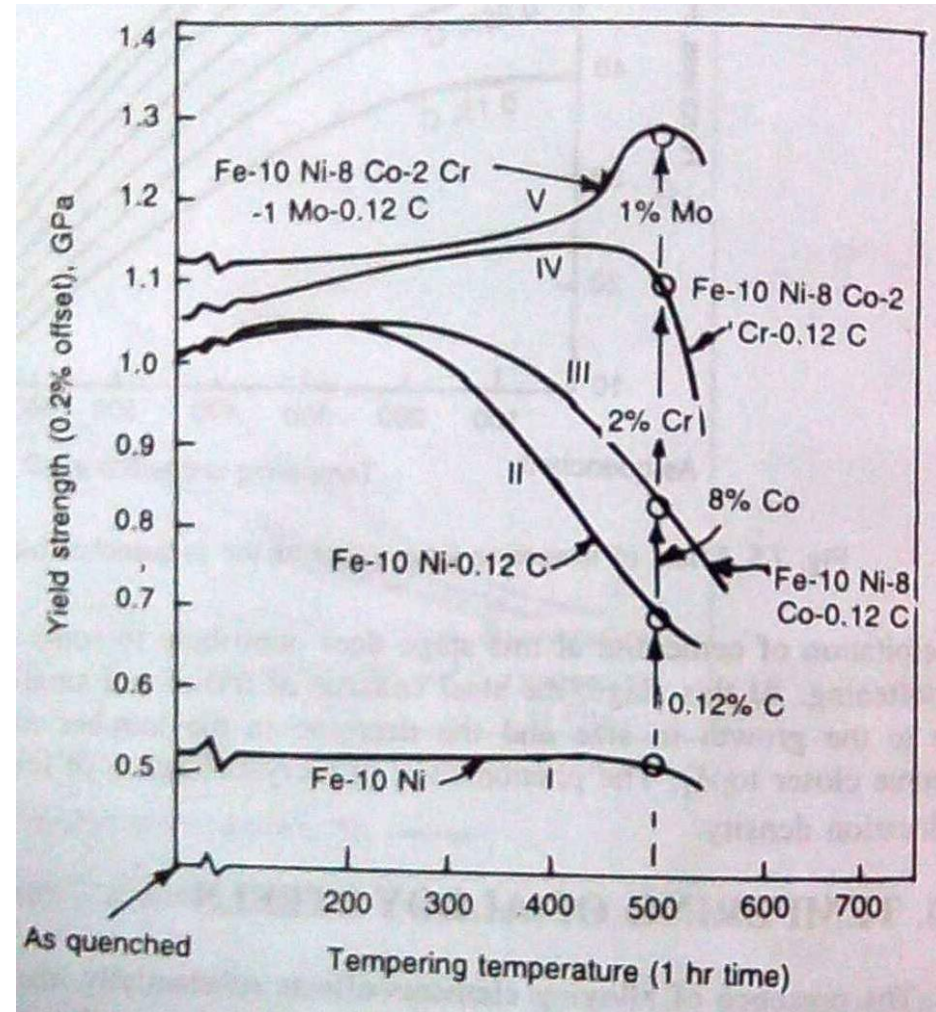

Effect of C, Co, Cr, and Mo on tempering of Fe-10Ni steels

Tempering of alloy steels : Secondary Hardening

- ❑ In alloy steels, having larger amounts of strong carbide forming elements like Mo, Ti, V, Nb, W, Cr etc., and carbon, a peculiar phenomena occurs, the hardness of the as-quenched martensite (called primary hardness) on tempering, decreases initially, as the tempering temperature is raised, but starts increasing again to often become higher than the as quenched hardness, with much improved toughness, when tempered in the range of 500 to 600°C. This increase in hardness is called **secondary hardness (also called red hardness)**.
- ❑ This is of great importance in high speed steels, as these are able to continue machining, at high speeds (as these are able to resist fall in hardness and thus, the cutting property) even when they become red hot.
- ❑ Secondary hardening is a process, similar to age hardening, in which coarse cementite particles are replaced by a new and much finer alloy carbide dispersion of V_4C_3 , Mo_2C , W_2C (which normally form on dislocations). As in aging a critical dispersion causes a peak in the hardness and strength of the alloy, and as over aging takes place, i.e., carbide dispersion slowly coarsens, the hardness decreases.
- ❑ Secondary hardening is best shown in steels containing Mo, V, W, Ti and also in Cr steels at high chromium concentrations.
- ❑ The amount of secondary hardening in an alloy steel is directly proportional to the volume fraction of the alloy carbides, and thus is directly proportional to the concentration of carbide forming elements present in steels. The alloy carbides must precipitate as a fine dispersion in ferrite matrix rather than massive carbide particles.

Time and Temperature relationship in Tempering

❑ For a given steel, a heat treater might like to choose some convenient tempering time, say over night, otherwise different than 1 hour, and thus, wants to calculate the exact temperature required to achieve the constant hardness.

❑ Hollomon and Jaffe's "tempering parameter" may be used for this purpose as it relates the hardness, tempering temperature and tempering time. For a thermally activated process, the usual rate equation is :

$$\text{Rate} = \frac{1}{t} = Ae^{-Q/RT}$$

❑ Where, t is the time of tempering to develop a given hardness, and Q is the 'empirical activation energy'. 'Q' is not constant in the complex tempering processes but varies with hardness. Thus, hardness was assumed to be a function of time and temperature:

$$H = f[te^{-Q/RT}]$$

❑ Interestingly, $[te^{-Q/RT}]$ is a constant, and let it be t_0 . Equating activation energies of eq (1)

and (2) gives,

$$Q = T[\ln t - \ln t_0] = f(H)$$

❑ As t_0 constant then

$$H = f[T(C + \ln t)]$$

❑ Where, C is a constant, whose value depends on the composition of austenite. The single parameter which expresses two variables time and the temperature i.e., $T(C + \ln t)$ is called

the Hollomon and Jaffe tempering parameter. (hardness in vickers is preferable)

Temperature and colours for Heating and Tempering of Steel

Colours of Hot Solid metal			°C	Process of Heat treatment	
	White		1500		
	Yellow white		1300	High speed steel hardening (1230-1300°C)	
	Yellow		1100		
	Orange Red		1000	Alloy steel hardening (800-1100°C)	
	Light-Cherry-Red		900		
	Cherry-red		800	Carbon steel hardening	
	Dark-red		700		
	Vary dark-red		500	High speed steel tempering (500-600°C)	
	Black red in dull light, or darkness		400		
	Steel gray		300	Carbon steel tempering (150-575°C)	
Colour of Oxide film			°C	Parts Heat treated	
	Steel Gray		327	Cannot be used for cutting tools	
	Pale-light blue		310	For springs	
	Purple		282	Spring and screw drivers	
	Brown		270	Axes, wood cutting tools	
	Gold		258	Shear blades, hammer faces, cold chisels	
	Dark-straw-light-brown		240	Punches and Dies	
	Light-Straw-Yellow		220	Steel cutting tools, files, paper cutters	

↑

HEAT COLOURS

↓

↑

↓
TEMPER COLOURS

Embrittlement during Tempering

- ❑ Normally, as the tempering progresses, the hardness and the strength decreases, but the ductility and impact strength increase. But in certain steels, there is an unexpected decrease of the impact strength in certain ranges of temperatures. This indicates that there are two main types of embrittlement during tempering.
 - Tempered Martensite Embrittlement (TME)
 - Temper Embrittlement
- ❑ Both these embrittlement raise the impact transition temperature (ITT) to higher temperature. Figure (below) indicates the increase in *impact transition temperature*, $\Delta(\text{ITT})$ due to TE in SAE 3140 steel.

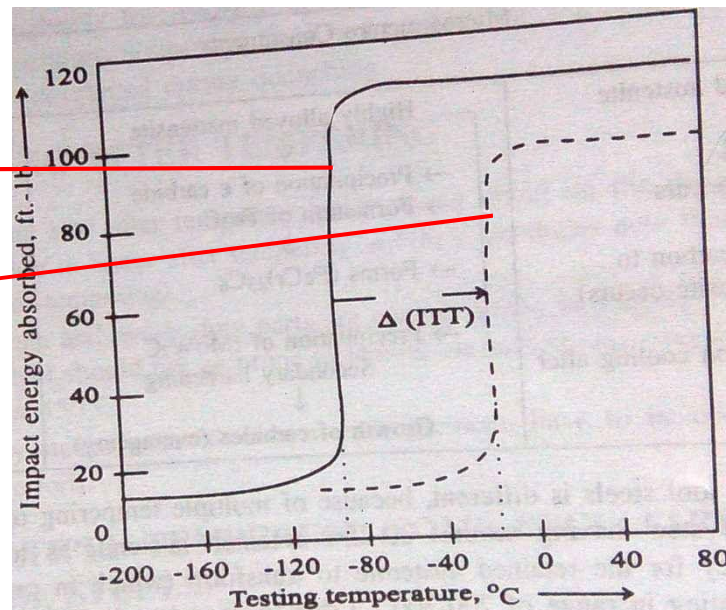

unembrittled

embrittled

Temper-embrittlement in SAE 3140 steel shifts the impact transition temperature to higher temperature. $\Delta(\text{ITT})$ indicates the amount of increase.

Embrittlement during Tempering

- ❑ Normally, the degree of both type of embrittlement is expressed in terms of relative displacements of ITT i.e., by Δ (ITT) illustrated in figure (in previous slide).
- ❑ In both the transgranular fracture mode is replaced by an intergranular (IG) mode below the transition temperature, i.e., these show bright inter crystalline fracture along original austenite grain boundaries.
- ❑ In spite of these similar effects, the two types of embrittlement are two separate phenomena, which occur in two different temperature ranges. Moreover, TME is a much faster process usually occurring in one hour, where as TE takes many hours.
- ❑ Temper embrittlement is of much greater concern from practical point of view, as the rotors and shafts of power generating equipment even after tempering above 600°C , develop it when thick section cool very slowly through the range ($450\text{-}600^{\circ}\text{C}$)

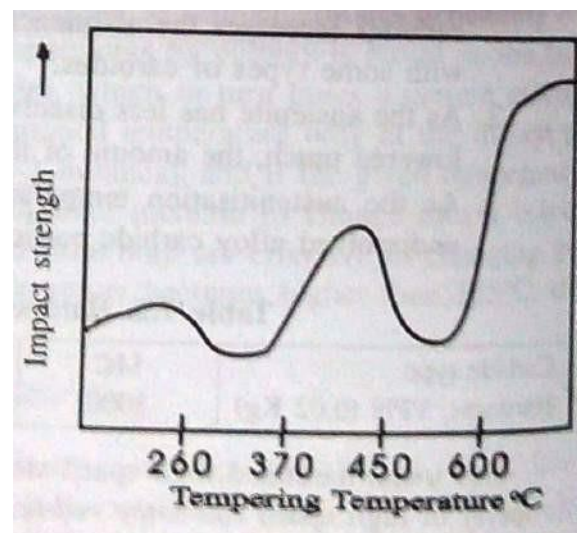

Schematic illustration of effect of tempering temperature on impact strength in steels prone to embrittlement during tempering.

Tempered Martensite embrittlement

- ❑ As TME develops after tempering in range 260°C to 370°C, it is called as “350°C” embrittlement, or 500°F embrittlement. It is called ‘one-step embrittlement’ as during heating only in this range, TME develops. It is also called ‘irreversible embrittlement because a steel embrittled by tempering in this range , if heated further to above 400°C (above the critical range), becomes tougher, and the tempered martensite embrittlement does not occur again if cooled down to or tempered in the range of 260°C to 370°C again.
- ❑ All steels, including the plain carbon steels are prone to irreversible embrittlement to some extent, and that is why tempering range of 260°C- 370°C is avoided in all steels, though it is a malady of low alloy steels.
- ❑ The embrittlement is associated with the change in the structure of carbide from epsilon (ϵ) to cementite in the form of a film at the grain boundaries.
- ❑ On tempering at higher temperatures, this film disappears and can not be restored, on repeated heating in 260°C-370°C temperature range.
- ❑ Although, tempered martensite embrittlement is concurrent with the precipitation of cementite, but such precipitation is not in itself the cause of loss of impact toughness, as the embrittlement is does not occur if P, Sb, Sn, As, or N are not present in steel.
- ❑ Addition of sufficient silicon to the steel inhibits the formation of cementite in the critical range, as silicon dissolved in epsilon carbide, increases its stability, and thus embrittlement does not occur

Temper embrittlement

- ❑ The sickness of alloy steels occurs when they are tempered in the range 450°C to 600°C. It is also called reversible embrittlement (as well as two step embrittlement), because it occurs, when steels are tempered in this range, but gets removed, when heated to high temperatures, but occurs again on slow continuous cooling through this range from that high temperature (>600°C). The degree of embrittlement depends on the rate of cooling in the range 600-450°C.
- ❑ The phenomena of temper embrittlement results in loss of toughness as measured by notched impact test (without affecting very much the hardness, Y.S, UTS, elongation and fatigue properties), and a rise in ductile to brittle transition temperature occurs, with an intergranular (IG) fracture, below the transition temperature along the original austenitic grain boundaries.
- ❑ Carbon steels in general, but with less than 0.5% Mn, do not show temper embrittlement. Alloy steels of high purity do not show it. It is caused primarily by Sb and P and secondarily by Sn or As (even in amounts as low as 0.01%) in presence of elements like Ni, Mn, Cr, Si in steels. The highest effect is in Ni-Cr and Mn-Cr steels. Presence of elements like Mo, Ti, Zr delay, or remove embrittlement.
- ❑ The characteristic features of temper embrittlement are best explained by the concept of co-segregation. The impurity solutes are the surface active elements in iron, i.e., these reduce the grain boundary energy, and thus reduce the cohesion. Elements like Sb, P, As, Sn, interact with certain elements like Ni and Mn in steels.

Temper embrittlement

- ❑ These interactions leads to co-segregation of alloying elements and the impurity elements such as between Ni-Sb, Ni-P-Ni-Sn and Mn-Sb. The reason of co-segregation is the stronger interaction between them than, between either of these and iron.
- ❑ If the interaction is very strong then, co-segregation does not occur, but a scavenging effect is got, as happens between Mo-P, Ti-P, which is the cause of elimination of embrittlement by 0.5% Mo in such steels. If larger amount of Mo, Ti, Zr are present , then these elements slowly react with carbon to form stable carbides releasing the impurity atoms to segregate to the boundaries.
- ❑ Additional segregation may take place, when two alloying elements are present simultaneously, such as Ni and Cr. At high temperatures ($>600^{\circ}\text{C}$), thermal vibrations make the equilibrium segregation low enough not to cause embrittlement., and at lower temperature ($<450^{\circ}\text{C}$), the diffusion of the elements is too low to cause enough co- segregation with in the normal tempering time.
- ❑ The following methods are normally recommended to minimize the effect of Temper embrittlement
 - ✓ Keep the impurities such as Sb, P, Sn, As as low as possible
 - ✓ Alloy the steel with Mo (0.5-0.75%)
 - ✓ Quench from tempering at higher temperatures

Heat Treatment Defects

- ❑ Heat treatment of steels or aluminum can lead to several defects. The principal types of defects found in quenching of steels are internal and external cracks in the work, distortion and warping.
- ❑ **CRACK** : When the internal tensile stresses exceed the resistance of the steel to separation the crack occurs. The insertion of the tools in the furnace without preheating for tempering is one of the main causes of crack propagation. The crack formation is reduced by preheating the tool between 200⁰C to 300⁰C.
- ❑ **DISTORTION** : Distortion occurs due to uneven heating, too fast cooling, part incorrectly supported in furnace, incorrect dipping in quenching and stresses present before preheating. Distortion can be prevented by preheating the tool or check furnace capacity, reduce the hardening temperature, and by reviewing the method of dipping.
- ❑ **WARPING** : Asymmetrical distortion of the work is often called warping in heat-treating practice. Warping is usually observed upon non-uniform heating or over heating for hardening. It also occurs when the work is quenched in the wrong position and when the cooling rate is too high in the temperature range of the martensite transformation. An elimination of these causes should subsequently reduce warping.
- ❑ The properties required in the heat treated part are obtained without the parts being distorted beyond the acceptable limits.
- ❑ The ideal design for a heat treatable part is the shape that when heated (or cooled) will have the same temperature at every point within the part.