

# Digital Notes

# COURSE MATERIAL

III Year B. Tech II- Semester  
(2023-2024)

MECHANICAL ENGINEERING



---

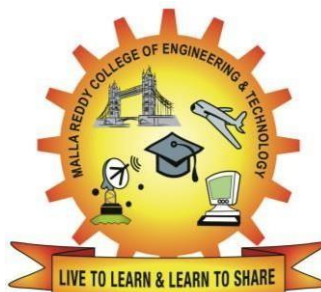
## AUTOMOBILE ENGINEERING

## R20A0326

---



**Prepared by:**  
**Dr. D. Damodara Reddy, Associate Professor**



**MALLA REDDY COLLEGE OF ENGINEERING & TECHNOLOGY**

**DEPARTMENT OF MECHANICAL ENGINEERING**

(Autonomous Institution-UGC, Govt. of India)  
Secunderabad-500100, Telangana State, India.

[www.mrcet.ac.in](http://www.mrcet.ac.in)

---



# MALLA REDDY COLLEGE OF ENGINEERING & TECHNOLOGY

(Autonomous Institution – UGC, Govt. of India)

## DEPARTMENT OF MECHANICAL ENGINEERING

---

### CONTENTS

1. Vision, Mission & Quality Policy
2. Pos, PSOs & PEOs
3. Blooms Taxonomy
4. Course Syllabus
5. Lecture Notes (Unit wise)
  - a. Objectives and outcomes
  - b. Notes
  - c. Presentation Material (PPT Slides/ Videos)
  - d. Industry applications relevant to the concepts covered
  - e. Question Bank for Assignments
  - f. Tutorial Questions
6. Previous Question Papers



# MALLA REDDY COLLEGE OF ENGINEERING & TECHNOLOGY

(Autonomous Institution – UGC, Govt. of India)

---

## VISION

- ❖ To establish a pedestal for the integral innovation, team spirit, originality and competence in the students, expose them to face the global challenges and become technology leaders of Indian vision of modern society.

## MISSION

- ❖ To become a model institution in the fields of Engineering, Technology and Management.
- ❖ To impart holistic education to the students to render them as industry ready engineers.
- ❖ To ensure synchronization of MRCET ideologies with challenging demands of International Pioneering Organizations.

## QUALITY POLICY

- ❖ To implement best practices in Teaching and Learning process for both UG and PG courses meticulously.
- ❖ To provide state of art infrastructure and expertise to impart quality education.
- ❖ To groom the students to become intellectually creative and professionally competitive.
- ❖ To channelize the activities and tune them in heights of commitment and sincerity, the requisites to claim the never - ending ladder of **SUCCESS** year after year.

For more information: [www.mrcet.ac.in](http://www.mrcet.ac.in)

# **MALLA REDDY COLLEGE OF ENGINEERING & TECHNOLOGY**

(Autonomous Institution – UGC, Govt. of India)

[www.mrcet.ac.in](http://www.mrcet.ac.in)

**Department of Mechanical Engineering**

---

## **VISION**

To become an innovative knowledge center in mechanical engineering through state-of-the-art teaching-learning and research practices, promoting creative thinking professionals.

## **MISSION**

The Department of Mechanical Engineering is dedicated for transforming the students into highly competent Mechanical engineers to meet the needs of the industry, in a changing and challenging technical environment, by strongly focusing in the fundamentals of engineering sciences for achieving excellent results in their professional pursuits.

## **Quality Policy**

- ✓ To pursuit global Standards of excellence in all our endeavors namely teaching, research and continuing education and to remain accountable in our core and support functions, through processes of self-evaluation and continuous improvement.
- ✓ To create a midst of excellence for imparting state of art education, industry-oriented training research in the field of technical education.

# MALLA REDDY COLLEGE OF ENGINEERING & TECHNOLOGY

(Autonomous Institution – UGC, Govt. of India)

www.mrcet.ac.in

Department of Mechanical Engineering

---

## PROGRAM OUTCOMES

Engineering Graduates will be able to:

- 1. Engineering knowledge:** Apply the knowledge of mathematics, science, engineering fundamentals, and an engineering specialization to the solution of complex engineering problems.
- 2. Problem analysis:** Identify, formulate, review research literature, and analyze complex engineering problems reaching substantiated conclusions using first principles of mathematics, natural sciences, and engineering sciences.
- 3. Design/development of solutions:** Design solutions for complex engineering problems and design system components or processes that meet the specified needs with appropriate consideration for the public health and safety, and the cultural, societal, and environmental considerations.
- 4. Conduct investigations of complex problems:** Use research-based knowledge and research methods including design of experiments, analysis and interpretation of data, and synthesis of the information to provide valid conclusions.
- 5. Modern tool usage:** Create, select, and apply appropriate techniques, resources, and modern engineering and IT tools including prediction and modeling to complex engineering activities with an understanding of the limitations.
- 6. The engineer and society:** Apply reasoning informed by the contextual knowledge to assess societal, health, safety, legal and cultural issues and the consequent responsibilities relevant to the professional engineering practice.
- 7. Environment and sustainability:** Understand the impact of the professional engineering solutions in societal and environmental contexts, and demonstrate the knowledge of, and need for sustainable development.
- 8. Ethics:** Apply ethical principles and commit to professional ethics and responsibilities and norms of the engineering practice.
- 9. Individual and teamwork:** Function effectively as an individual, and as a member or leader in diverse teams, and in multidisciplinary settings.
- 10. Communication:** Communicate effectively on complex engineering activities with the engineering community and with society at large, such as, being able to comprehend and write effective reports and design documentation, make effective presentations, and give and receive clear instructions.
- 11. Project management and finance:** Demonstrate knowledge and understanding of the engineering and management principles and apply these to one's own work, as a member and leader in a team, to manage projects and in multidisciplinary environments.

# MALLA REDDY COLLEGE OF ENGINEERING & TECHNOLOGY

(Autonomous Institution – UGC, Govt. of India)

www.mrcet.ac.in

## Department of Mechanical Engineering

---

**12.Life-long learning:** Recognize the need for and have the preparation and ability to engage in independent and life-long learning in the broadest context of technological change.

### **PROGRAM SPECIFIC OUTCOMES (PSOs)**

- PSO1** Ability to analyze, design and develop Mechanical systems to solve the Engineering problems by integrating thermal, design and manufacturing Domains.
- PSO2** Ability to succeed in competitive examinations or to pursue higher studies or research.
- PSO3** Ability to apply the learned Mechanical Engineering knowledge for the Development of society and self.

### **Program Educational Objectives (PEOs)**

The Program Educational Objectives of the program offered by the department are broadly listed below:

#### **PEO1: PREPARATION**

To provide sound foundation in mathematical, scientific and engineering fundamentals necessary to analyze, formulate and solve engineering problems.

#### **PEO2: CORE COMPETANCE**

To provide thorough knowledge in Mechanical Engineering subjects including theoretical knowledge and practical training for preparing physical models pertaining to Thermodynamics, Hydraulics, Heat and Mass Transfer, Dynamics of Machinery, Jet Propulsion, Automobile Engineering, Element Analysis, Production Technology, Mechatronics etc.

#### **PEO3: INVENTION, INNOVATION AND CREATIVITY**

To make the students to design, experiment, analyze, interpret in the core field with the help of other inter disciplinary concepts wherever applicable.

#### **PEO4: CAREER DEVELOPMENT**

To inculcate the habit of lifelong learning for career development through successful completion of advanced degrees, professional development courses, industrial training etc.

# **MALLA REDDY COLLEGE OF ENGINEERING & TECHNOLOGY**

(Autonomous Institution – UGC, Govt. of India)

[www.mrcet.ac.in](http://www.mrcet.ac.in)

**Department of Mechanical Engineering**

---

## **PEO5: PROFESSIONALISM**

To impart technical knowledge, ethical values for professional development of the student to solve complex problems and to work in multi-disciplinary ambience, whose solutions lead to significant societal benefits.

# MALLA REDDY COLLEGE OF ENGINEERING & TECHNOLOGY

(Autonomous Institution – UGC, Govt. of India)

[www.mrcet.ac.in](http://www.mrcet.ac.in)

Department of Mechanical Engineering

---

## Blooms Taxonomy

Bloom's Taxonomy is a classification of the different objectives and skills that educators set for their students (learning objectives). The terminology has been updated to include the following six levels of learning. These 6 levels can be used to structure the learning objectives, lessons, and assessments of a course.

1. **Remembering:** Retrieving, recognizing, and recalling relevant knowledge from long-term memory.
2. **Understanding:** Constructing meaning from oral, written, and graphic messages through interpreting, exemplifying, classifying, summarizing, inferring, comparing, and explaining.
3. **Applying:** Carrying out or using a procedure for executing or implementing.
4. **Analyzing:** Breaking material into constituent parts, determining how the parts relate to one another and to an overall structure or purpose through differentiating, organizing, and attributing.
5. **Evaluating:** Making judgments based on criteria and standard through checking and critiquing.
6. **Creating:** Putting elements together to form a coherent or functional whole; reorganizing elements into a new pattern or structure through generating, planning, or producing.

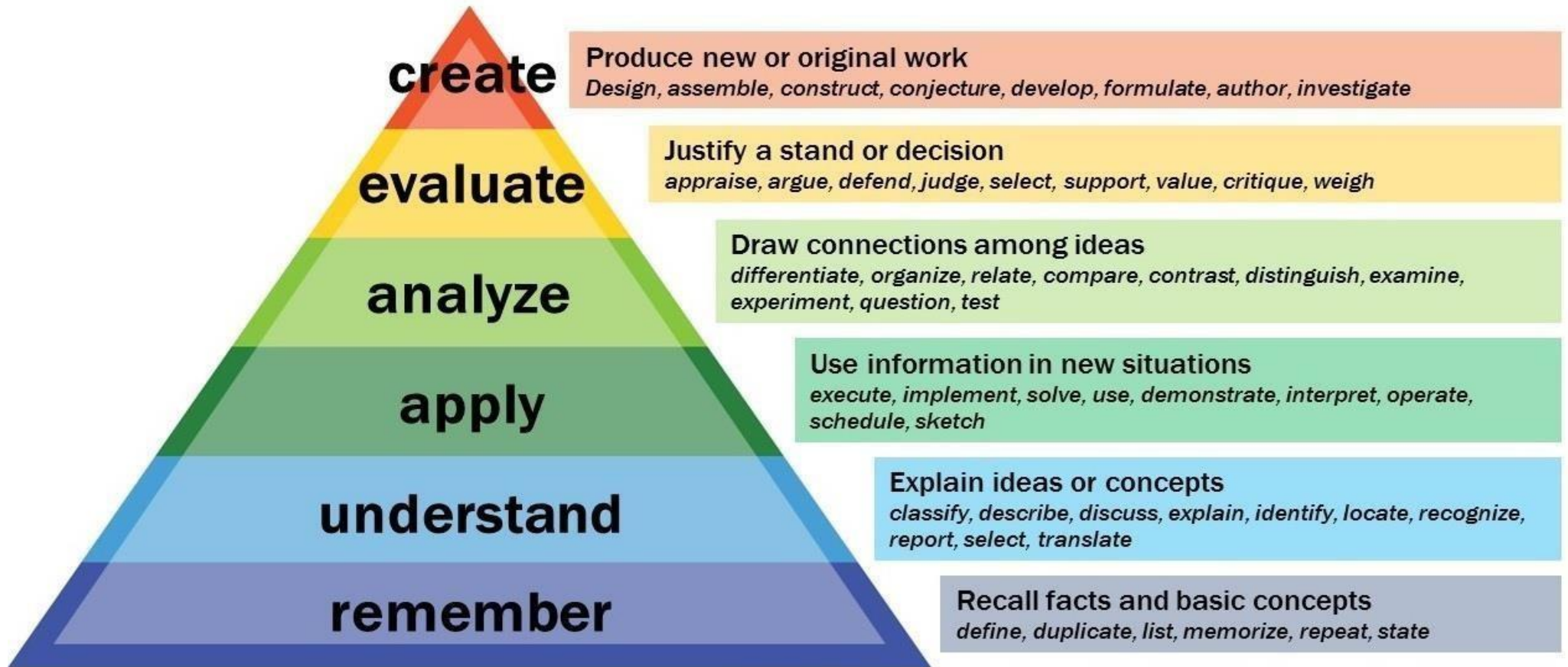
# MALLA REDDY COLLEGE OF ENGINEERING & TECHNOLOGY

(Autonomous Institution – UGC, Govt. of India)

[www.mrcet.ac.in](http://www.mrcet.ac.in)

Department of Mechanical Engineering

---



# MALLA REDDY COLLEGE OF ENGINEERING & TECHNOLOGY

IV Year B. Tech, ME-II Sem

L	T/P/D	C
3	0	3

## (R18A0331) AUTOMOBILE ENGINEERING

### Objectives:

- The objective of this subject is to provide knowledge about various systems involved in automobile engine.
- Able to learn about different components of IC Engines.
- Different automobile engine systems line diagrams.

### UNIT –I VEHICLE STRUCTURE AND ENGINES

Types of automobiles vehicle construction and different layouts, chassis, frame and body, Vehicle aerodynamics (various resistances and moments involved), IC engines components-functions and materials, variable valve timing (VVT).

### UNIT –II ENGINE AUXILIARY SYSTEMS

Electronically controlled gasoline injection system for SI engines, Electronically controlled diesel injection system (Unit injector system, Rotary distributor type and common rail direct injection system), Electronic ignition system (Transistorized coil ignition system, capacitive discharge ignition system), Turbo chargers (WGT, VGT), Engine emission control by three way catalytic converter system, Emission norms (Euro and BS).

### UNIT –III TRANSMISSION SYSTEMS

Clutch-types and construction, gear boxes- manual and automatic, gear shift mechanisms, Over drive, transfer box, fluid flywheel, torque converter, propeller shaft, slip joints, universal joints, Differential and rear axle, Hotchkiss Drive and Torque Tube Drive.

### UNIT –IV STEERING, BRAKES AND SUSPENSION SYSTEMS

Steering geometry and types of steering gear box-Power Steering, Types of Front Axle, Types of Suspension Systems, Pneumatic and Hydraulic Braking Systems, Antilock Braking System (ABS), electronic brake force distribution (EBD) and Traction Control.

### UNIT –V ALTERNATIVE ENERGY SOURCES

Use of Natural Gas, Liquefied Petroleum Gas, Bio-diesel, Bio-ethanol, Gasohol and Hydrogen in Automobiles- Engine modifications required Performance, Combustion and Emission Characteristics of SI and CI engines with these alternate fuels - Electric and Hybrid Vehicles, Fuel Cells.

**TEXT BOOKS:**

1. Jain K.K. and Asthana .R.B, Automobile Engineeri Tata McGraw Hill Publishers, New Delhi, 2002.
2. Kirpal Singh, Automobile Engineering, Vol 1 & 2, Seventh Edition, Standard Publishers, New Delhi, 13th Edition 2014.

**REFERENCE BOOKS:**

1. Ganesan V. Internal Combustion Engines, Third Edition, Tata McGraw-Hill, 2012.
2. Heinz Heisler, Advanced Engine Technology, SAE International Publications USA, 1998.
3. Joseph Heitner, Automotive Mechanics, Second Edition, East-West Press, 1999.
4. Martin W, Stockel and Martin T Stockle , Automotive Mechanics Fundamentals, The Good heart - Will Cox Company Inc, USA ,1978.
5. Newton ,Steeds and Garet, Motor Vehicles, Butterworth Publishers,1989.

**OUTCOMES:**

- The Automotive Engineering program aims to provide practice-oriented education based on the latest scientific results and methods.
- Which enable students to work independently as automotive engineers.
- Enables to face increasing challenges and standards of global markets.



---

**UNIT I**

**VEHICLE STRUCTURE AND  
ENGINES**

---



## **Introduction of Automobile or Vehicle:**

An Automobile is a self-propelled vehicle which contains the power source for its propulsion and is used for carrying passengers and goods on the ground, such as car, bus, trucks, etc.,

### **Types of Automobile:**

The automobiles are classified by the following ways,

#### **1. On the Basis of Load:**

- Heavy transport vehicle (HTV) or heavy motor vehicle (HMV),
- Light transport vehicle (LTV), Light motor vehicle (LMV),

#### **2. On the Basis of Wheels:**

- Two wheeler vehicle, for example: Scooter, motorcycle, scooty, etc.
- Three wheeler vehicle, for example : Autorickshaw,
- Three wheeler scooter for handicaps and tempo, etc.
- Four wheeler vehicle, for example: Car, jeep, trucks, buses, etc.
- Six wheeler vehicle, for example: Big trucks with two gear axles.

#### **3. On the basis of Fuel Used:**

- Petrol vehicle, e.g. motorcycle, scooter, cars, etc.
- Diesel vehicle, e.g. trucks, buses, etc.
- Electric vehicle which use battery to drive.
- Steam vehicle, e.g. an engine which uses steam engine.
- Gas vehicle, e.g. LPG and CNG vehicles, where LPG is liquefied

#### **4. On the basis of body style:**

- Sedan Hatchback car.
- Coupe car Station wagon Convertible.
- Van Special purpose vehicle, e.g. ambulance, milk van, etc.

#### **5. On the basis of Transmission:**

- Conventional vehicles with manual transmission, e.g. car with 5 gears.

- Semi-automatic
- Automatic : In automatic transmission, gears are not required to be changed manually.

#### **6. On the basis of Drive:**

- Left hand drive
- Right hand drive

#### **7. On the basis of Driving Axle**

- Front wheel drive
- Rear wheel drive
- All wheel drive

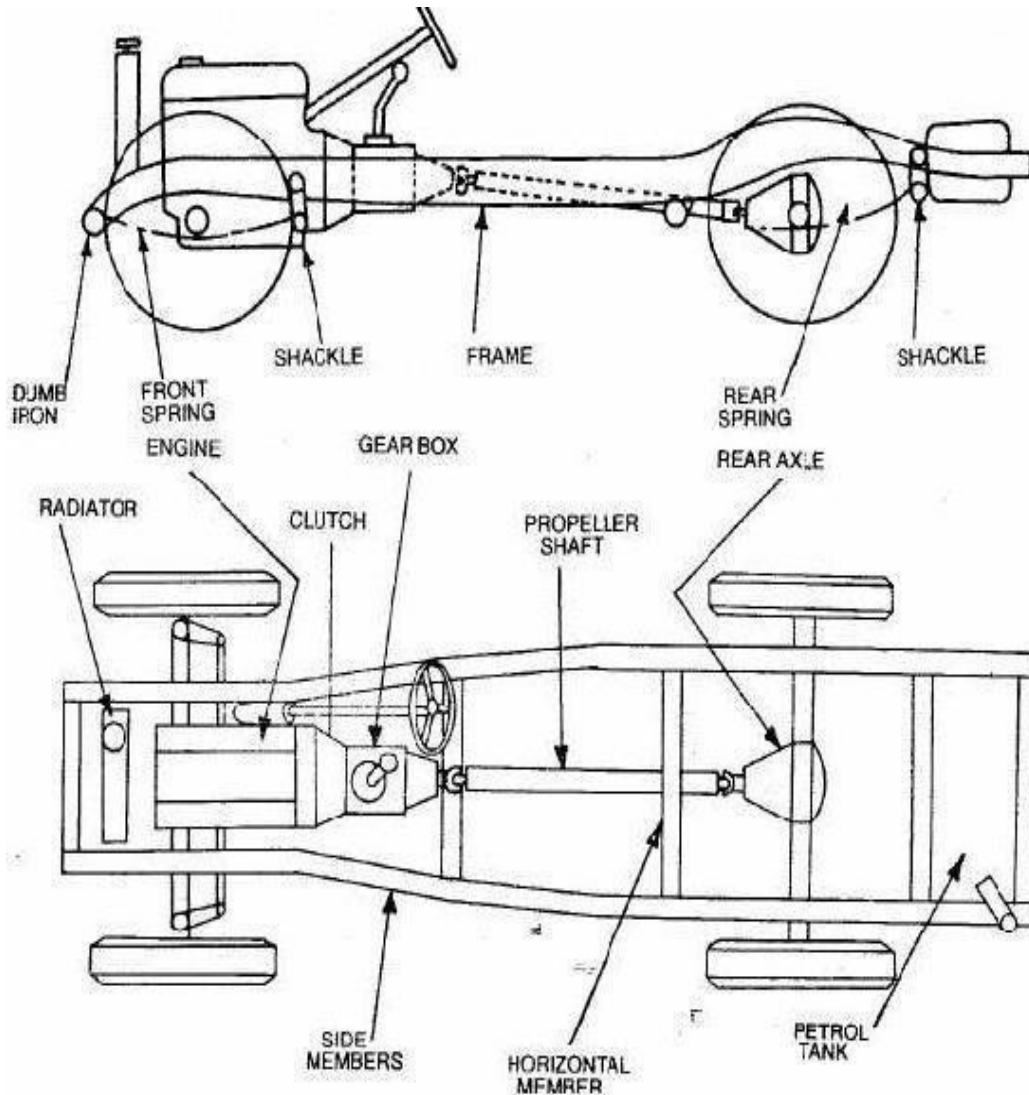
#### **8. Position of Engine:**

- Engine in Front - Most of the vehicles have engine in the front. Example : most of the cars,
- Engine in the Rear Side Very few vehicles have engine located in the rear.  
Example : Nano car.

### **Vehicle construction and Components;**

The main components of an automobile refer to the following components;

- Frame,
- Chassis,
- Body,
- Power unit,
- Transmission system.



An automobile is made up of mainly two units, these are Chassis and Body.

“Frame” + “Base components” = “Chassis”

“Chassis” + “Body” = Vehicle

- Chassis include the following
  - Springs and Shock absorbers
  - Steering System
  - Brakes
  - Frame
  - Tyres and Wheels
- Transmission Units includes
  - Clutches
  - Gear box
  - Universal Joint
  - Final Drive
  - Axle and Differential
- Engine Units Includes
  - Full System
  - Ignition System
  - Lubricating System
  - Cooling system
- Electrical System Includes
  - Battery
  - Dynamometre
  - Alternators
  - Ignition Starting and Lighting

## Frame:

The frame is the skeleton of the vehicle. It serves as a main foundation and base for alignment for the chassis.

## Types;

- Conventional frame,
- Semi integral frame;
- Integral or unitized frame.

### Conventional Frame

- Most of the heavy vehicles.
- Made up of steel section.
- 2 long side members & 5 to 6 cross members joined rivets or bolts.
- Cross members increased strength.
- Front – inswept (narrow): Steering lock, pivoting & swinging of the front wheels.
- Rear – upswept (Board): vertical movement of the rear axles, road bumps & inequalities.

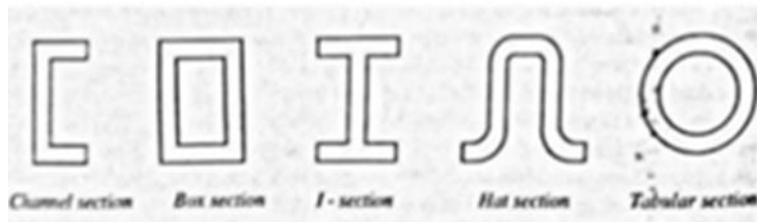


Fig.1 Cross section of ladder chassis

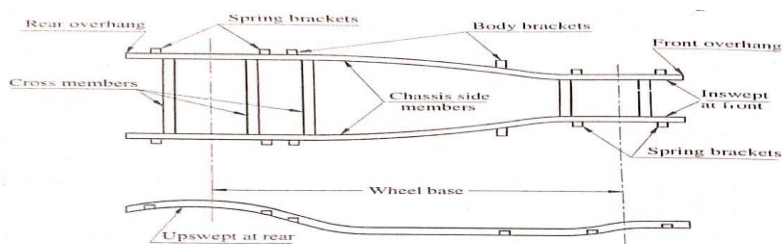


Fig. 1(a) Ladder Chassis

### Intergal Frame

- In this type of construction, there is no frame. It is also called unitized frame-body construction.
- All the assembly units are attached to the body and all the functions of the frame carried out by the body itself.
- Here the body shell and underbody are welded into single unit. The underbody is made of floor plates and channel and box sections welded into single unit. This assembly replaces the frame.
- This frame is used now days in most of the cars. Due to elimination of long frame it is cheaper and due to less weight most economical also.
- The main disadvantage is repairing



Fig.2 Integral Frame

### **Semi Integral Frame**

- In some vehicles half frame is fixed in the front end on which engine gear box and front suspension is mounted.
- In this case the rubber mountings used in conventional frame between frame and suspension are replaced by more stiff mountings.
- Because of this some of the vehicle load is shared by the frame also. This type of frame is heavier in construction.
- It has the advantage when the vehicle is met with accident the front frame can be taken easily to replace the damaged chassis frame.
- This type of frame is used in some of the European and American cars.



Fig.3 Semi Integral Frame

## **Chassis;**

If the frame contains the base components its called as chassis. The components are like Engine, radiator, clutch, gearbox, silencer, road wheels, fuel tank, wirings, differential units, etc..,

### **FUNCTIONS OF A CHASSIS**

1. Supports or bears the load of the vehicle body.
2. Provide the space and mounting location for various aggregates of vehicle.
3. Supports the weight of various systems of the vehicle such as engine, transmission etc.
4. Supports a load of passengers as well as the luggage.
5. Withstands the stresses arising due to bad road conditions.
6. Withstands stresses during braking and acceleration of the vehicle.

### **Types of Chassis**

- i. Ladder Chassis
- ii. Tubular Chassis
- iii. Monocoque Chassis

### **Ladder Chassis**

The ladder-frame chassis is one of the oldest chassis types. This chassis is characterised by two long heavy beams that are supported by two smaller ones. Its quality of being easily manufactured not only made it contemporarily popular but also eased the way for its mass production. Since ladder frame chassis is significantly heavy it's usually used for vehicles that transport heavy material.

#### **Benefits**

- Easy to manufacture and easy assembling of the car over it.
- Heavy and strong tensile strength.

#### **Drawbacks**

- Poor cornering ability due to weak torsional rigidity
- Its heaviness doesn't make it suitable for performance cars and hatchbacks.

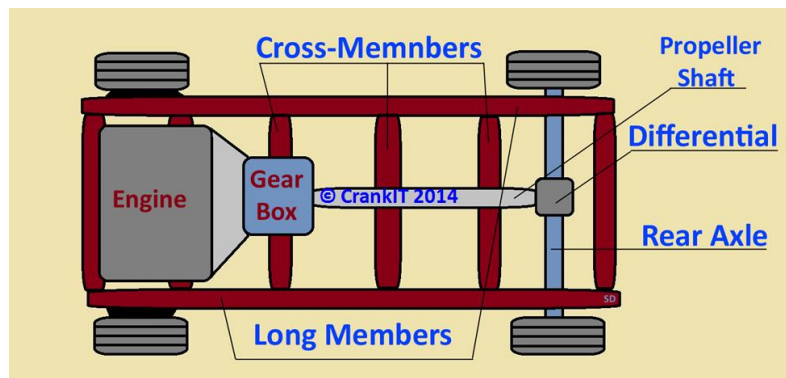


Fig.4 Ladder chassis frame layout

### Tubular Chassis

- Tubular space frame chassis employs dozens of circular-section tubes (some may use square-section tubes for easier connection to the body panels, though circular section provides the maximum strength), position in different directions to provide mechanical strength against forces from anywhere.
- This type of chassis is mostly used while manufacturing racing cars due to the enhanced safety they offer.

#### Benefits

- Its crafting allows better contact between the half axle and ground making it preferable for off-roading.
- A cylindrical tube covering the driveshaft saves it from any damage while off-roading.
- The structure's torsional toughness is relatively more supple than ladder chassis.

#### Drawbacks

- In case the driveshaft fails, the whole chassis needs to be dismantled as the driveshaft is covered with the cylindrical tube of the chassis.
- The manufacture of backbone chassis is costly and increases the overall cost of the car.

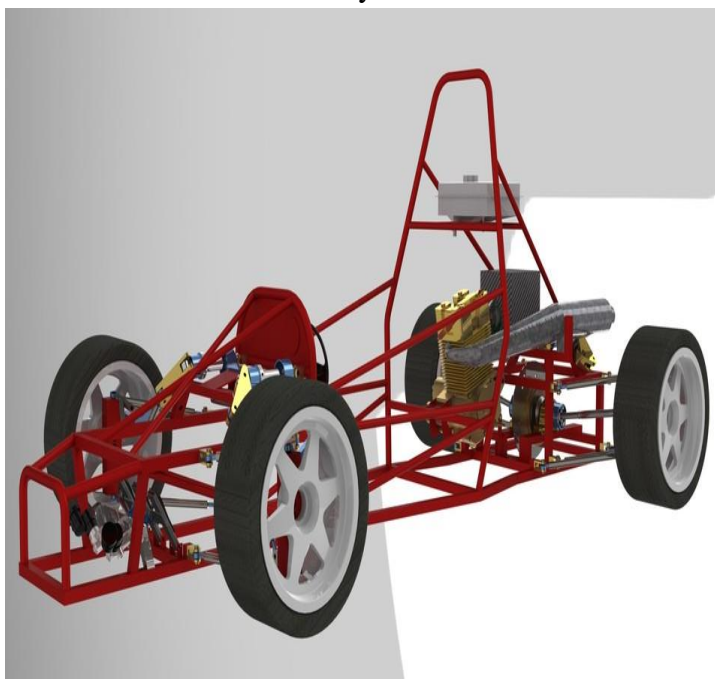


Fig.5 Tubular Chassis

## Monocoque Chassis

- The construction of a monocoque chassis is quite simple in the sense that the entire structure is one big construction.
- All components or mechanical parts constitute the frame, foundation and body of the car.
- The engine, gearbox, suspension, seats and exterior body panels are simply attached to the construction. This means that the overall construction is very lightweight and compact. There is quite a lot of safety element to it.
- The applications include all sorts of everyday vehicles ranging from small and compact hatchbacks to large and heavy SUVs. It must be noted that modern SUVs are using monocoque construction quite a bit which was not always the case in the past

## Benefits

- It's safer than both the other chassis due to its cage-like construction.
- The chassis is easy to repair as well.
- It has superior torsional rigidity.

## Drawbacks

- The chassis is obviously heavy as it's both the frame and chassis as one single entity.
- Producing it in small quantities is not financially feasible and thus it cannot be used for cars that are not mass-produced.

## Body:

- Body is the super-structure for all vehicles. It may either be constructed separately and bolted to the chassis or manufactured integral with the chassis (i.e. Frameless construction).
- The chassis and the body make the complete vehicle.
- A body consists of windows and doors, engine cover, roof, luggage cover etc. The electrical system in the body is connected to the chassis electrical units so that the battery and the generator/alternator can furnish the required electrical energy to the system.

## Types;

- Car, Truck, Tractor, Delivery Van, Ambulance, jeep, Bus, etc..,

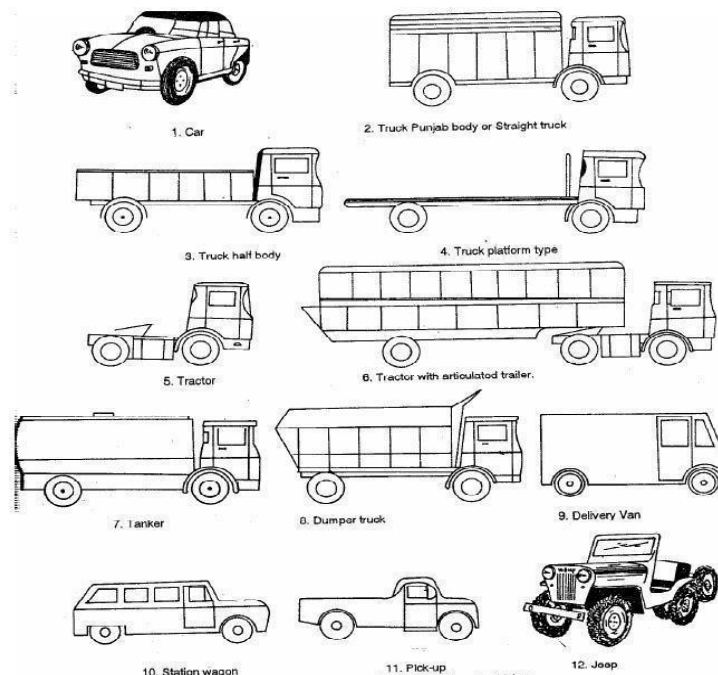


Fig.6. Body of various vechiles

## Description of an Automobile

- **Type:** Motor Cycle, Car, Bus, truck, etc.,
- **Capacity:** Tonnage and no. of seats
- **Make:** Manufacturer of the vehicle and Engine Capacity
- **Drive:** Left hand Drive or Right hand Drive, 2, 4, 6 wheel drive
- **Model:** Year of Manufacturing

## Layouts of an Automobile

The different layouts of an automobile are as follows

- Front Engine Rear Wheel Drive
- Front Engine Front Wheel Drive
- Rear Engine Rear Wheel Drive
- Four Wheel Drive (All Wheel Drive)

### 1. Front Engine Rear Wheel Drive

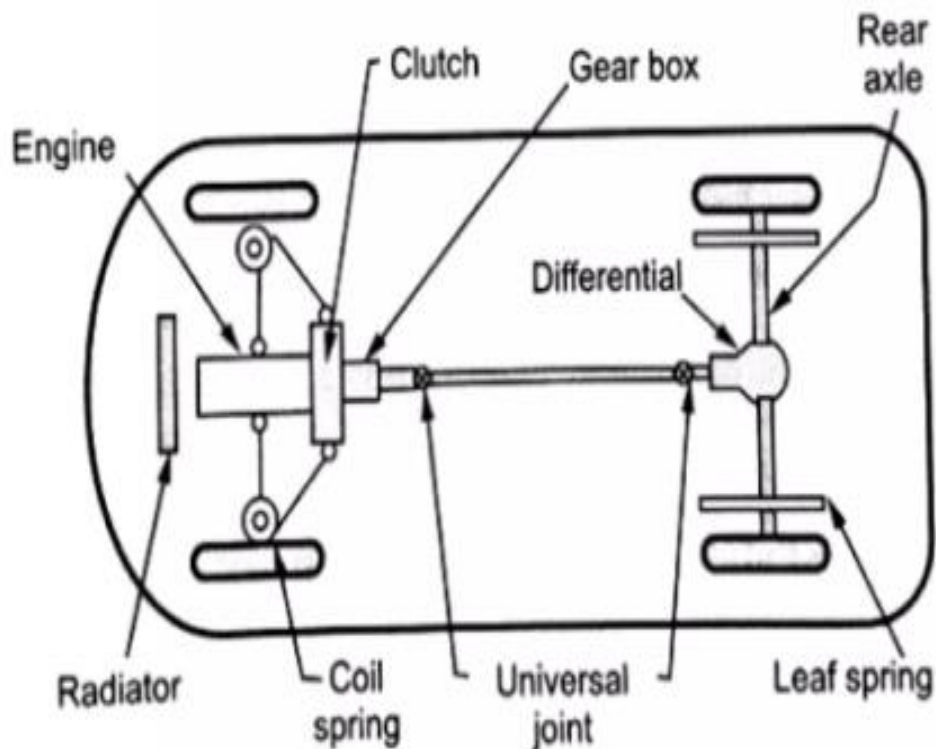


Fig.7 layout of Front engine rear wheel drive

In this chassis layout, the engine is fitted at the front.

- The engine, clutch and gear box are fitted at front while drive to the rear axle is given with the help of propeller shaft
- This chassis layout is one of the oldest and still remain popular for heavy commercial vehicle

### Advantages

1. The weight distribution is reasonably balanced between the front and rear wheels, which gives good handling characteristics.
2. Due to engine and radiator are at front, the forward facing radiator takes full benefit of the natural air stream, created by vehicle's movement. Hence reduce the power losses for a large fan.
3. The weight of vehicle is shifted to rear driving wheels during acceleration and on steep resulting in better road grip, hence, there are less chances of wheel slipping.
4. Since the front wheel are used only to steer the vehicle, hence steering mechanism become simple in design and easy to operate.

5. Accessibility to various components like engine , gear box and rear axle is better in comparison to outer layout
6. Large luggage space is available at back of vehicle which providing increased carrying capacity as well as space for easy body extension.

#### Dis Advantages

1. During the breaking ,weight of vehicle is fitted to front wheels and weight on rear wheels decreased , results in decreased breaking effort developed
2. It required long propeller shaft and differential at rear, therefore height of floor area is increased .Also, due to long propeller shaft transmission problems and weight are increased.
3. Due to less weight on driving rear wheels, there is less adhesion on road and result in less holding capacity .therefore there is less chance of skidding on slippery surface.

#### 2. Front Engine Front Wheel Drive

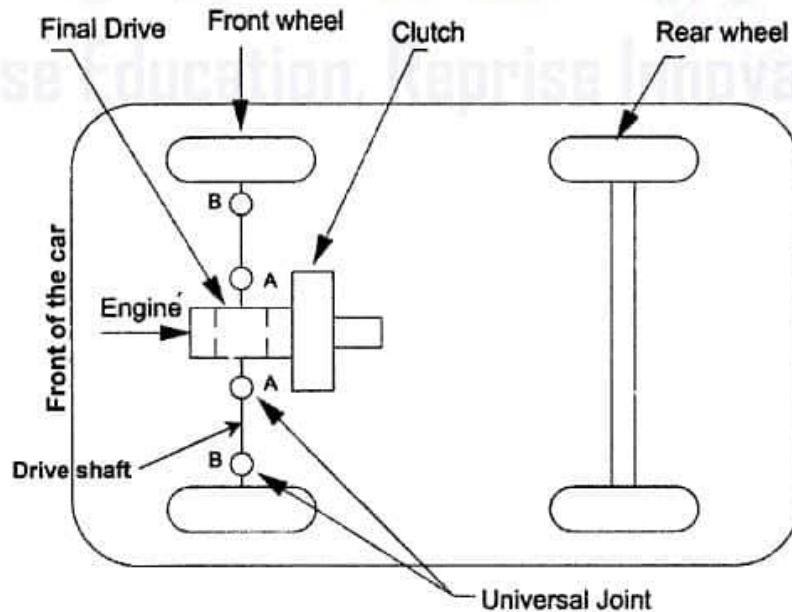


Fig.8 layout of Front engine Front wheel drive

1. In this type of chassis layout the engine is fitted at front and drive is also given to the front wheel .No propeller shaft is used in this layout and differential are included in the same assembly.
2. This layout provides optimum body luggage space and flat floor line. However , due to all assemblies at front ,it make very difficult to accommodate the steering mechanism.

#### Advantages

1. Due to more weight placed on driving front wheel, the vehicle has more adhesion on road. Hence good road holding capacity even on the curves and slippery roads.
2. This layout provides low floor, since no propeller shaft and the differential placed at front instead of rear.
3. The clutch, gearbox, and final drive usually made as one unit thereby coast of vehicle are reducing.
4. The wheel does not take to sharply turn into the curve due to tendency of understeering. The understeer conditions generally preferred by many drivers are promoted by this type of chassis.
5. Either a transverse or longitudinal engine position can be used. In case of transverse mounted engine, as the engine crankshaft and wheels already rotate in the parallel planes, therefore, they do not require their drive to be turned through  $90^{\circ}$  as in case of conventional longitudinally mounted engines.

#### Dis Advantages

1. The weight on the driving front wheels is reduced during acceleration and climbing of steep gradient due to weight of the vehicle shifting to the rear wheels. Hence, result in decreased tractive effort which makes slippery gradient

- The steering mechanism become more complicated due to accommodation of engine, clutch, gearbox & final drive all at front of vehicle.

### 3. Rear Engine Rear Wheel Drive

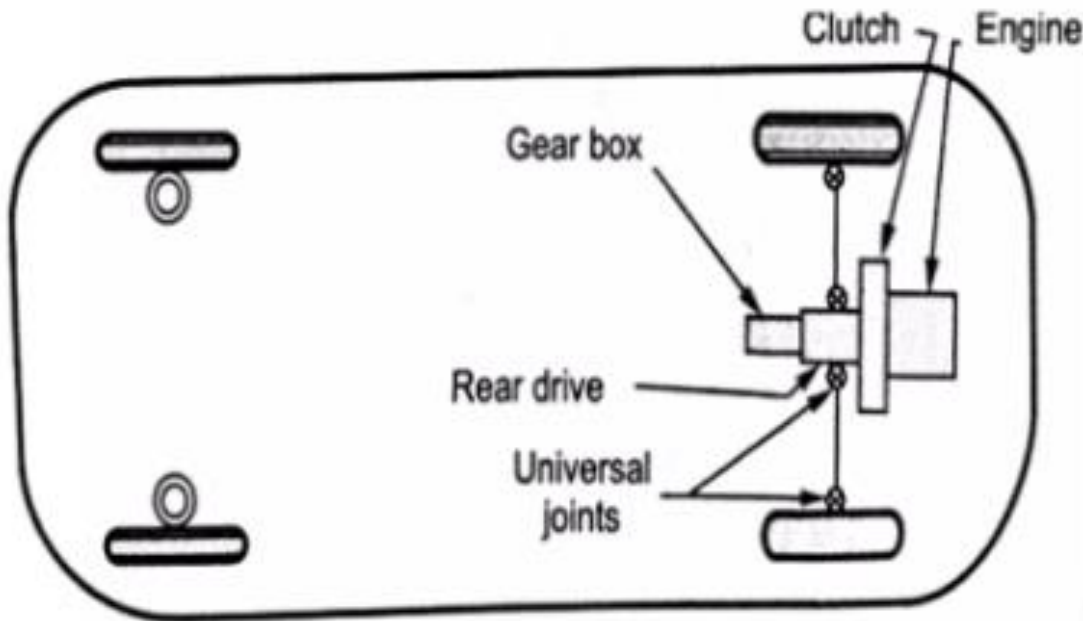


Fig.9 layout of Rear engine rear wheel drive

In this chassis layout engine is fitted at the back and drive is also given to rear wheel

- This arrangement eliminates the necessity for a propeller shaft because engine is mounted near the driven wheel.
- The passenger are kept away from inconveniences like noise, heat and fumes because engine at back of vehicle

#### Advantages

1. Because of high weight on driving axle, it provides excellent traction and grip on steep hills
2. The rear floor can be made flat because of absence of propeller shaft.
3. The clutch, gearbox, and final drive usually made as one unit thereby coast of vehicle are reducing.
4. The driver cabin is well isolated from noise
5. The front body can be designed with steam lining and stylish.

#### Dis Advantages

1. Natural air cooling of the engine is not possible, hence it requires powerful radiator fan at rear.
2. The clutch and gear system mechanism is long and complex
3. Because of high weight concentration at rear, the vehicle has a tendency to over steer while taking harp turns

### 4. Four Wheel Drive (All wheel Drive)

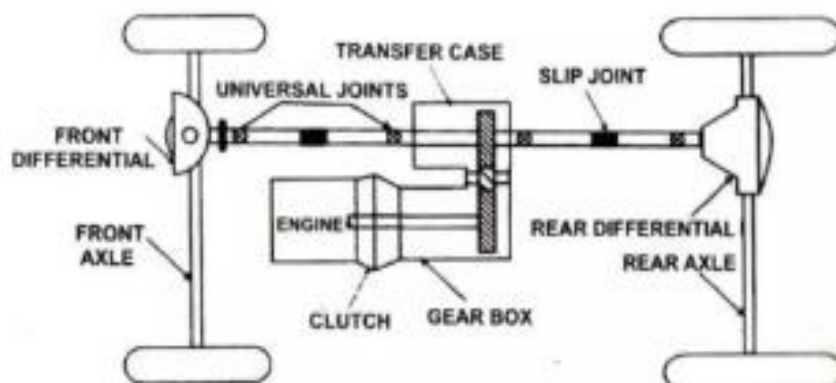


Fig.10 layout of All wheel drive

- 4X2 = 4 Wheel vehicle and 2 Wheels can receive torque.
- 4X4 = 4 Wheel vehicle and all 4 Wheels can receive torque.
- E.g. are Jeeps, SUVs (Sports Utility Vehicle), etc.
- Games derived its name from 4WD only.
- Used mostly in defense services or where graveled or slick roads are present.
- To get enough “TRACTION” between wheels and road surfaces.
- To move vehicle on slick surfaces, dirt, slippery roads, sand roads and snowy, muddy roads etc.

## **Advantages**

- Increased Traction is obtained in slippery surfaces.
- More balanced axle load distribution.
- Even tire wear

## **Dis Advantages**

- Weight of vehicle is increased.
- Cost of the vehicle is increased.
- Maximum speed of vehicle is reduced.
- Less fuel economy than 2WD

## **Vehicle Aero Dynamics**

The term “Aero” means air, “Dynamic” means motion. Therefore, aerodynamic is the study of effects of the wind on the vehicle in motion.

When the vehicle is moving the air flow is dependent on the two factors.

- Vehicle speed.
- Ambient wind.

## **Advantages of Aerodynamics**

- More Fuel Efficiency
- Higher Speeds
- Good Aesthetic and Stylish Appearance
- More Stability of car at high Speed
- Reduce Noise Level

## **Resistance of an Automobile**

- ✓ A moving vehicle is opposed by various forces, known as resistance
- ✓ For moving the vehicle, the driving force (F) should be equal to the sum of all resistance forces applied on it.  $F = R_a + R_r + R_g$
- ✓ When ‘F’ exceeds the sum of all resistance forces, vechile accelerate
- ✓ When ‘F’ less than the sum of all resistance forces, vechile deaccelerate

**Air Resistance ( $R_a$ ):** This is the resistance offered by air to the movement of a vehicle. The air resistance has an influence on the performance, ride and stability of the vehicle and depends upon the size and shape of the body of the vehicle, its speed and the wind velocity. The last term should be taken into account when indicated, otherwise it can be neglected. Hence in general, air resistance,

- **It increases as the square of the vehicle speed owing to which much importance is given to streamlining and frontal area of modern automobiles. In calculating air resistance, air velocity is usually neglected.**

Air resistance,  $R_a = k_a AV^2$

where,  $k_a$  = Coefficient of air resistance,  
 $A$  = Projected frontal area,  $m^2$ , and  
 $V$  = Vehicle speed, km/h.

**Rolling Resistance ( $R_r$ ):** The magnitude of rolling resistance depends mainly on

- the nature of road surface,
- the types of tyre viz. pneumatic or solid rubber type,
- the weight of the vehicle, and
- the speed of the vehicle

- **It is measured in kg or N and is expressed as kg/tonne or N/tonne of vehicle weight or as a percentage of the vehicle weight. Rolling resistance on average type of road surface is between 1 to 2% of vehicle weight.**

Rolling resistance,  $R_r = k_r W$

where,  $k_r$  = Constant of rolling resistance, and  
 $W$  = Total weight of vehicle.

**Gradient Resistance ( $R_g$ ):** The resistance due to steepness of the road gradient. It depends upon the weight of the vehicle and road gradient. It does not depend upon vehicle speed.

- **Gradient resistance,  $R_g = \frac{W}{G}$ , or,  $W \sin \theta$**

(if gradient is expressed in angular dimensions)

where,  $W$  = Total weight of vehicle,

$G$  = Gradient, and

$\theta$  = Inclination. (For small values,  $\tan \theta = \sin \theta$ )

**MOMENTS DUE TO FORCES:** Moments created by forces acting on the vehicle

Rolling Moment – Created by cross wind about x-axis

Pitching moment – Created by drag or lift force about y-axis and reduces the traction in the wheels

Yawing moment- Created by cross wind about z-axis

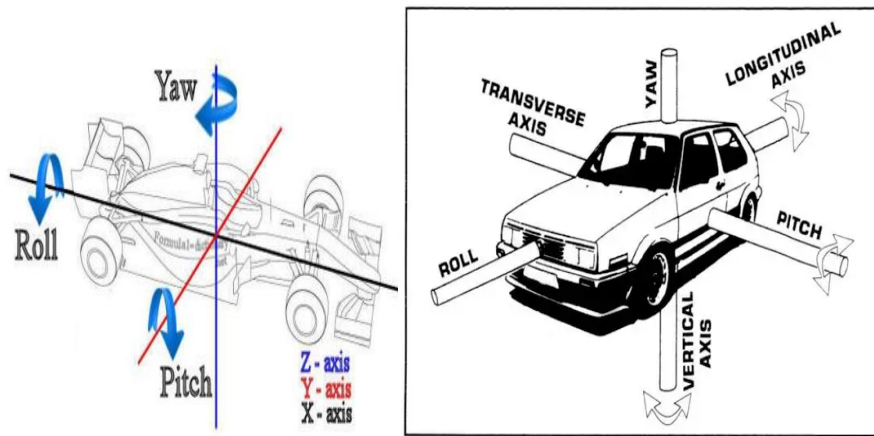


Fig.11 Moments of Forces acting on the Body

## Components of an Engine:

Even though reciprocating internal combustion engines look quite simple, there are hundreds of components that have to perform their functions satisfactorily to produce output power. There are two types of engines, viz., spark ignition (SI) and compression-ignition (CI) engine. Let us now go through the important engine components and the nomenclature associated with an engine.

## Terms connected with I.C. engines;

**Bore:** The inside diameter of the cylinder is called bore

**Stroke:** The linear distance along the cylinder axis between two limiting positions is called stroke.

**Top Dead Center ( T.D.C. ) :** the top most position of the piston towards cover end side of the cylinder is called T.D.C.

**Bottom dead Center ( B.D.C. ) :** The lowest position of the piston towards the crank end side of the cylinder is called B.D.C.

**Clearance Volume:** The volume contained in the cylinder above the top of the piston, when the piston is at top dead center, is called the clearance volume.

**Swept Volume:** The volume swept through by the piston in moving between T.D.C. and B.D.C, is called swept volume or piston displacement.

**Compression Ratio:** It is the ratio of Total cylinder volume to clearance volume.

## Definition of 'Engine'

An engine is a device, which transforms one form of energy into another form. Normally, most of the engines convert thermal energy into mechanical work and therefore they are called 'heat engines'.

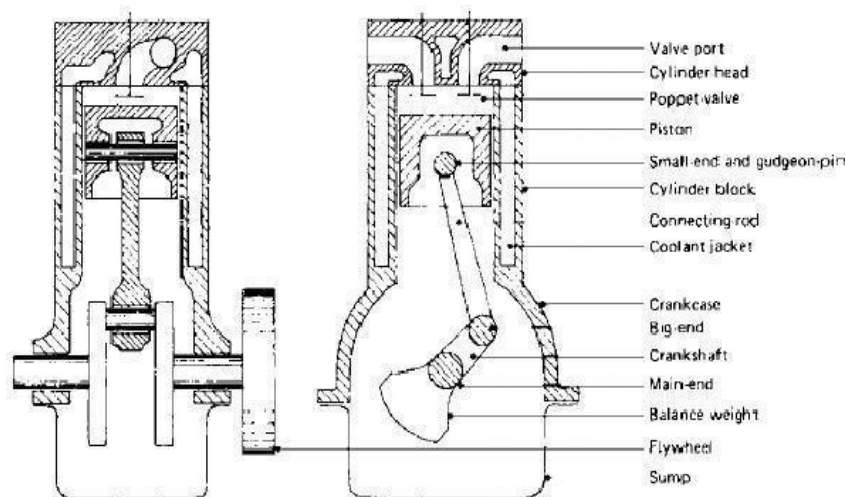


Fig.12 parts of an I.C. Engine

## Engine Components

The major components of the engine and their functions are briefly described below.

### Cylinder Block:

The cylinder block is the main supporting structure for the various components. The cylinder of a multi cylinder engine is cast as a single unit, called cylinder block. The cylinder head is mounted on the cylinder block.

The cylinder head and cylinder block are provided with water jackets in the case of water-cooling with cooling fins in the case of air-cooling. Cylinder head gasket is incorporated between the cylinder block and cylinder head. The cylinder head is held tight to the cylinder block by number of bolts or studs. The bottom portion of the cylinder block is called crankcase. A cover called crankcase, which becomes a sump for lubricating oil is fastened to the bottom of the crankcase. The inner surface of the cylinder block, which is machined and finished accurately to cylindrical shape, is called bore or face.

## **Cylinder**

As the name implies it is a cylindrical vessel or space in which the piston makes a reciprocating motion. The varying volume created in the cylinder during the operation of the engine is filled with the working fluid and subjected to different thermodynamic processes. The cylinder is supported in the cylinder block.

## **Piston**

It is a cylindrical component fitted into the cylinder forming the moving boundary of the combustion system. It fits perfectly (snugly) into the cylinder providing a gas-tight space with the piston rings and the lubricant. It forms the first link in transmitting the gas forces to the output shaft.

## **Combustion Chamber**

The space enclosed in the upper part of the cylinder, by the cylinder head and the piston top during the combustion process, is called the combustion chamber. The combustion of fuel and the consequent release of thermal energy results in the building up of pressure in this part of the cylinder.

## **Inlet Manifold**

The pipe which connects the intake system to the inlet valve of the engine and through which air or air-fuel mixture is drawn into the cylinder is called the inlet manifold.

## **Gudgeon Pin**

It forms the link between the small end of the connecting rod and the piston.

## **Exhaust Manifold**

The pipe that connects the exhaust system to the exhaust valve of the engine and through which the products of combustion escape into the atmosphere is called the exhaust manifold.

## **Inlet and Exhaust Valves**

Valves are commonly mushroom shaped poppet type. They are provided either on the cylinder

head or on the side of the cylinder for regulating the charge coming into the cylinder (inlet valve) and for discharging the products of combustion (exhaust valve) from the cylinder.

### **Connecting Rod**

It interconnects the piston and the crankshaft and transmits the gas forces from the piston to the crankshaft. The two ends of the connecting rod are called as small end and the big end. Small end is connected to the piston by gudgeon pin and the big end is connected to the crankshaft by crankpin.

### **Crankshaft**

It converts the reciprocating motion of the piston into useful rotary motion of the output shaft. In the crankshaft of a single cylinder engine there is pair of crank arms and balance weights. The balance weights are provided for static and dynamic balancing of the rotating system. The crankshaft is enclosed in a crankcase.

### **Piston Rings**

Piston rings, fitted into the slots around the piston, provide a tight seal between the piston and the cylinder wall thus preventing leakage of combustion gases

### **Camshaft**

The camshaft and its associated parts control the opening and closing of the two valves. The associated parts are push rods, rocker arms, valve springs and tappets. This shaft also provides the drive to the ignition system. The camshaft is driven by the crankshaft through timing gears.

### **Cams**

These are made *as* integral parts of the camshaft and are designed in such a way to open the valves at the correct timing and to keep them open for the necessary duration.

### **Fly Wheel**

The net torque imparted to the crankshaft during one complete cycle of operation of the engine fluctuates causing a change in the angular velocity of the shaft. In order to achieve a uniform torque an inertia *mass* in the form of a wheel is attached to the output shaft and this wheel is called the flywheel.

## **Basic Parts of the Gasoline Engine:**

Basic Parts of the Gasoline Engine are listed below;

- Cylinder block
- Piston
- Piston rings
- Piston pin
- Connecting rod
- Crankshaft
- Cylinder head
- Intake valve
- Exhaust valve
- Camshaft
- Timing gears
- Spark plug

### **Cylinder Block:**

Cylinder Block Basic frame of gasoline engine. Contains the cylinder.

### **Piston:**

Piston A sliding plug that harnesses the force of the burning gases in the cylinder.

### **Piston Rings:**

Piston rings seal the compression gases above the piston keep the oil below the piston rings.

### **Piston Pins:**

Piston Pins Also known as the wrist pin, it connects the piston to the small end of the connecting rod. It transfers the force and allows the rod to swing back and forth.

### **Connecting Rod:**

Connecting Rod Connects the piston and piston pin to the crankshaft.

**Crankshaft:**

Crankshaft Along the the piston pin and connecting rod it converts the up and down motion (reciprocating) of the engine to spinning (rotary) motion.

**Flywheel:**

Flywheel Carries the inertia when there is no power stroke.

**Cylinder Head:**

Cylinder Head Forms the top of the combustion chamber. Contains the valves, the passageways for the fuel mixture to move in and out of the engine.

**Intake and Exhaust Valves:**

Intake and Exhaust Valves Doorway that lets the gases in and out of the engine.

**Camshaft:**

Camshaft Through the use of an eccentric the cam lobes push the valves open. The valve springs close them.

**Timing Gears:**

Timing Gears These gears drive the camshaft from the crankshaft.

**Variable Valve Timing**

It is inherent to the operation of internal combustion engines to possess inlet and exhaust valves (4-stroke) or ports (2-stroke) for proper functioning. The idea here is to entrap the incoming fresh charge in a well-designed combustion chamber and then initiate ignition in order to release and convert the stored fuel chemical energy into the thermal energy. Subsequent to this release of energy, a mechanical system, such as piston-connecting-rod-crankshaft, is needed for conversion of the thermal energy into the mechanical energy of the crankshaft. The incoming fresh charge usually consists of fuel, air, and possibly exhaust gas recirculated (EGR) chemical species. EGR is used for nitric oxide ( $\text{NO}_x$ ) emission control purposes. In this scenario, the roles that valves, particularly the intake valves, play are critical for the engine's efficient operation, optimum performance, and minimization of pollutants emission. In this tutorial, these aspects are addressed in a concise manner.

Historically speaking, many different types of valves and valve actuation mechanisms have been tried in the past. Most have disappeared to the point that at present time nearly all 4-stroke

engines use poppet valves opened by a cam and closed by a spring. A typical valve timing for a 4-stroke engine is shown in Fig. 1. At wide open throttle operation of an SI engine, the exhaust gases rushing out of the exhaust valve can assist pulling fresh charge into the cylinder (moving the intake manifold fresh charge even before the piston has moved appreciably), therefore justifying opening of the intake valve (IVO) even before TDC, see Fig. 1. At part load operation, however, situation is a bit more complex and the below-atmospheric pressure created by the partially open throttle valve can become less than the chamber pressure at the time when intake valve is opened. This causes backflow of burned gases from the cylinder into the intake system during the valve overlap period. The overlap period is the time during which both intake and exhaust valves are open (intake is being opened and exhaust being closed). Too early IVO will also cause fresh charge to be lost out of the exhaust, for example, NASCAR engines.

At the closing, it is customary to delay the IVC beyond the BDC to take advantage of the inertia of the fresh charge rushing into the engine, see Fig. 1. This will increase what is referred to as the “volumetric efficiency” of the engine. The volumetric efficiency indicates the breathing ability of the engine and is defined as the actual mass of the fresh air trapped in the cylinder (after valves are closed) divided by the theoretical mass of air calculated based on the piston displacement volume. The higher the volumetric efficiency, the higher the engine ability to trap fresh air, providing opportunity for combustion of a more mass of fuel on account of a more entrapped oxygen, thereby producing higher power for the same piston displacement. Furthermore, the engine brake power rises and then falls off with speed for a number of reasons: mainly the fall in volumetric efficiency, and the fall in mechanical efficiency. The delayed closure of the intake valve for achieving higher volumetric efficiency usually works best at higher engine speeds due to sufficiently high inertia of the incoming fresh charge. Note that the IVO does also affect the volumetric efficiency through the magnitude of the backflow into the intake system mentioned earlier.

In engines, even though attempts are made to thoroughly scavenge the chamber from burned gases, there is always a certain amount of burned gases left to be mixed with the incoming fresh charge. As far as the combustion (really, flame burning rate) is concerned, the amount of this residual burned gases left from the previous cycle combustion is not desirable. The higher the quantity of residual burned gases, the slower the flame mass burning rate. It is known that increases in the valve overlap period will elevate the fraction of the residual gases in the entrapped charge. Also, past research indicates that the amount of the residual gases correlates inversely with the engine load (i.e. throttle valve position in SI engines), being maximum at idle condition. This is the primary reason for engine stability problems at idle condition. It should therefore be clear that the valve overlap period can affect engine stability and hence efficiency. On the positive side, this residual gases is useful to lower the burned gases

temperature after combustion is complete, reducing the  $\text{NO}_x$  emissions. Figure 2 shows effects of the valve overlap period on emissions of  $\text{NO}_x$  and hydrocarbon (HC) at two different engine loads.

In summary, adjustments in valve timing (usually achieved by camshaft phasing) affect the raw emissions, engine torque/power, and idle stability. However, researchers have shown benefits in tailoring valve lift profile, primarily to achieve higher efficiency and power, although emission benefits were also seen. Combination of adjustments in valve timing and changes in valve lift are being used to influence both emission levels and engine efficiency and, hence, fuel economy. Finally, potential of SI engine load control is being considered through variable lift designs. Research has shown that improvements in fuel economy and emission can be achieved through an optimized combination of variable valve timing and lift, see Fig. 3. To conclude, the adjustment of the valve timing in spark-ignited (SI) engines is dictated by a set of conflicting targets and goals. These goals cannot be achieved with fixed valve timing. Systems that provide variable timing and lift have recently found widespread use in engine design.

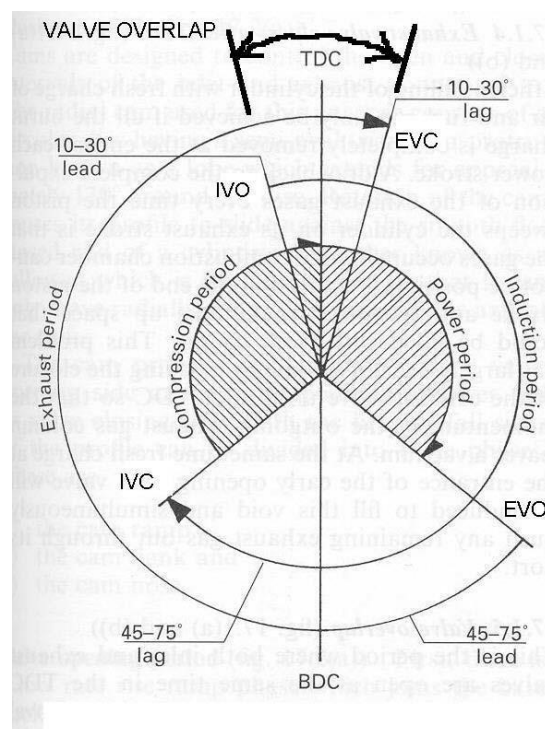


Figure 13. Indicates positions of intake and exhaust valves openings and closures with respect to the top-dead and bottom-dead centers, TDC and BDC respectively. TDC and BDC indicate the uppermost and lowermost positions of the piston top on the diagram. The angles shown are crankshaft angles. EVO and EVC are exhaust valve opening and closures angles.

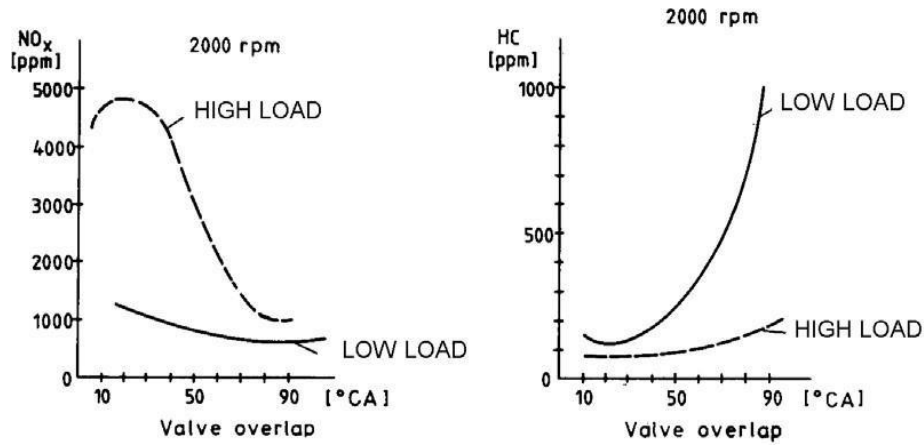


Figure 14. Effects of valve overlap on emission of pollutants at 2000 rpm and two different engine loads. HC and NO<sub>x</sub> are hydrocarbon and nitric oxides emissions.



---

**UNIT II**

**ENGINE AUXILIARY SYSTEMS**

---



## UNIT -II

### ENGINE AUXILIARY SYSTEMS

#### **Electronic Controlled Gasoline (Petrol) Injection System (ECGIS)**

The electronic Fuel injector system consists of three different systems for the basic operation of ECGIS

1. Fuel Delivery System
2. Air Induction system
3. Electronic Control System

#### **Fuel delivery system:**

- The Fuel delivery system consists of Fuel tank, fuel pump, fuel filter, Fuel delivery pipe, fuel injector, fuel pressure regulator and fuel return pipe
- Fuel is delivered from the tank to the injector by means of an electric fuel pump. The pump is typically located in or near to the tank. Contaminants are filtered out by a high capacity in line fuel filter.
- Fuel is maintained at a constant pressure by means of a fuel pressure regulator. Any fuel which is not delivered to the intake manifold by the injector is returned to the tank through a fuel return pipe.

#### **Air induction system:**

- The air induction system consists of the air cleaner, air flow metre, throttle valve, air intake chamber, intake manifold runner and intake valve.
- When the throttle valve is opened, air flows through the air cleaner, through the air flow meter (on L type system), past the throttle valve and through a well-tuned intake manifold runner to the intake valve.
- Air delivered to the engine is a function of driver demand. As the throttle valve is opened further, more air is allowed to enter the engine cylinders.

#### **Electronic control System (ECS):**

- The ECS consists of various engine sensors, Electronic control unit, Fuel injector assemblies and related wiring.
- The ECS determines precisely how much fuel needs to be delivered by the injector by monitoring the engine sensors.
- The ECS turns the injector for a precise amount of time, referred to as injection pulse width or injection duration, to deliver fuel so that proper air/fuel ratio is delivered to the engine.

#### **Basic Operation of ECGIS**

- Air enters the engine through the air induction system where it is measured by the air flow meter. As the air flows into the cylinder, fuel is mixed into the air by the fuel injector.
- Fuel injector is arranged in the intake manifold behind each intake valve. The injector is electrical solenoids which are operated by the ECU.
- The ECU pulses the injector by switching the injector ground circuit on and off.

- When the injector is turned on, it opens, spraying atomized fuel at the back side of the intake valve.
- As the Fuel is sprayed into the intake air stream, it mixes with the incoming air and vaporizes due to the low pressures in the intake manifold. The ECU signals the injector to deliver just enough fuel to achieve an ideal air/fuel ratio of 14.7:1, often referred to as stoichiometric ratio.
- The precise amount of fuel delivered to the engine is a function of ECU control. The ECU determines the basic injection quantity based upon measured intake air volume and engine rpm.
- Depending on engine operating conditions, injection quantity will vary. The ECU monitors variables such as coolant temperature, engine speed, throttle angle and exhaust oxygen content and makes injection corrections which determine final injection quantity.

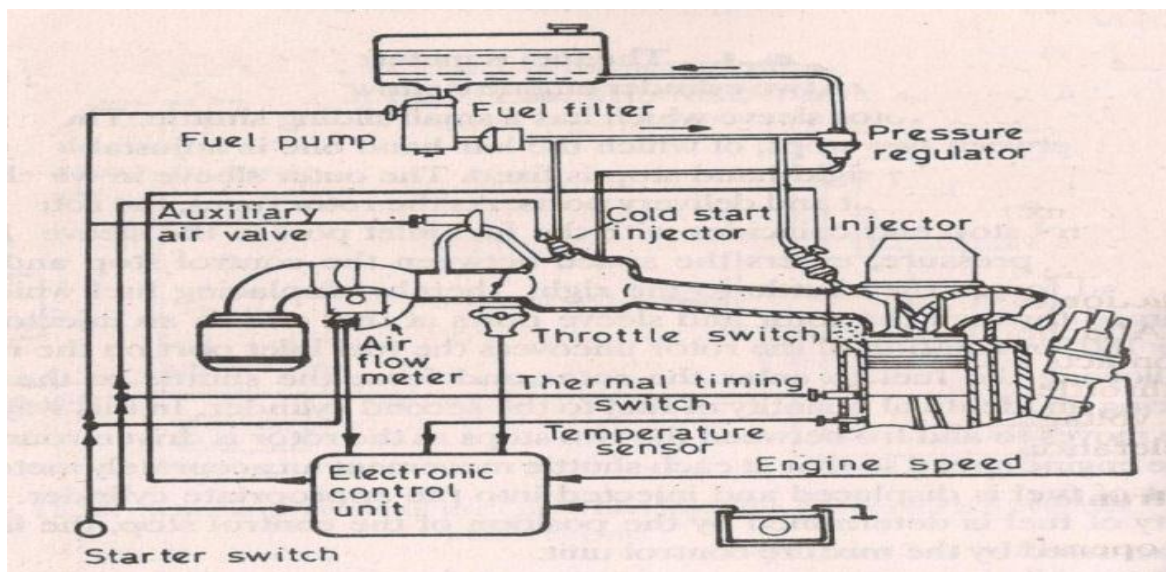


Fig.1 Electronic control gasoline injection system- L-Jetronic with air flow meter

### Advantages of Electronic Controlled Gasoline (Petrol) Injection System

- Uniform Fuel/Air mixture distribution
- High Accurate Fuel/Air Ration Control
- Superior Throttle Response and Control
- Excellent Fuel Economy
- Improved Cold engine Start ability
- Simple Mechanics and Reduced Adjustment Sensitivity.

### Single Point Injector System

- It has only one injector that injects the fuel before entering into the intake manifold.
- In this system, the fuel is mixed with fuel before the throttle valve. The single-point fuel injection system is also known as throttle body injection.
- The amount of fuel to be injected is decided by the engine control unit. The engine control unit takes the input from different sensors and decides the amount of fuel to be supplied for the injection.
- The fuel injector sprays the fuel for mixing with the flow of air and this air-fuel mixture enters the intake manifold.

The intake manifold further distributes the mixture to all cylinders.

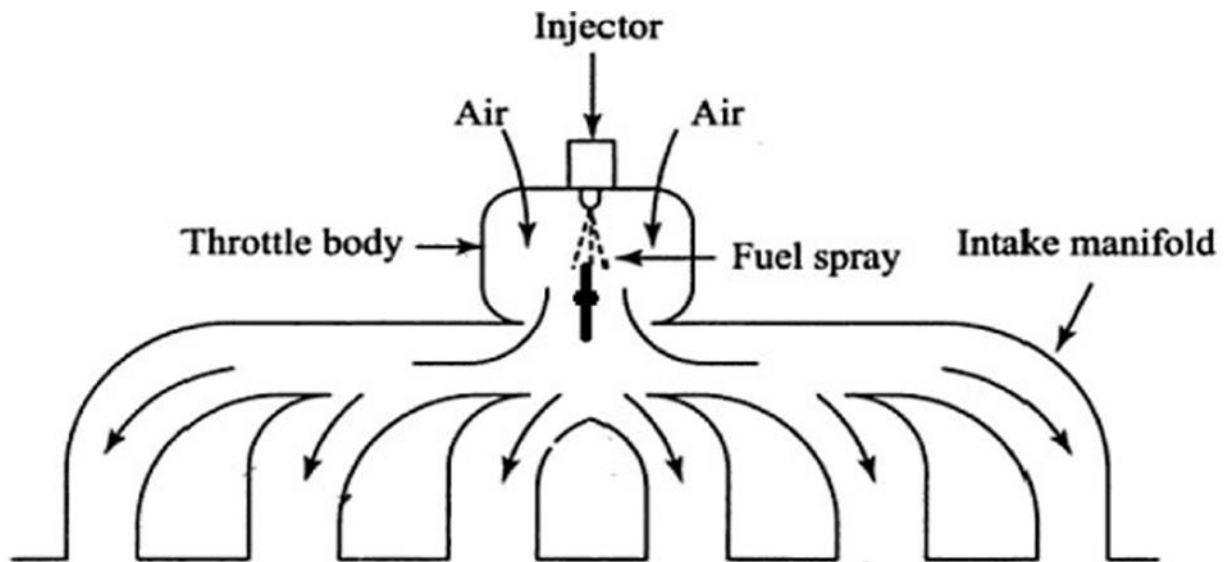


Fig. Throttle body injection (Single point)

### Advantages

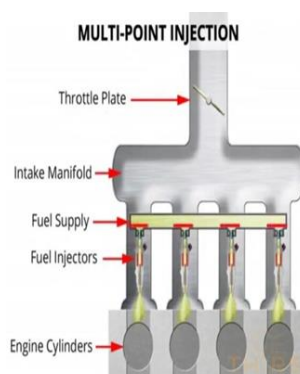
- Simple construction.
- Accurate fuel supply (in comparison with carburetor).
- Easy maintenance.
- It uses only a single injector.
- Reliable operation

### Dis Advantages

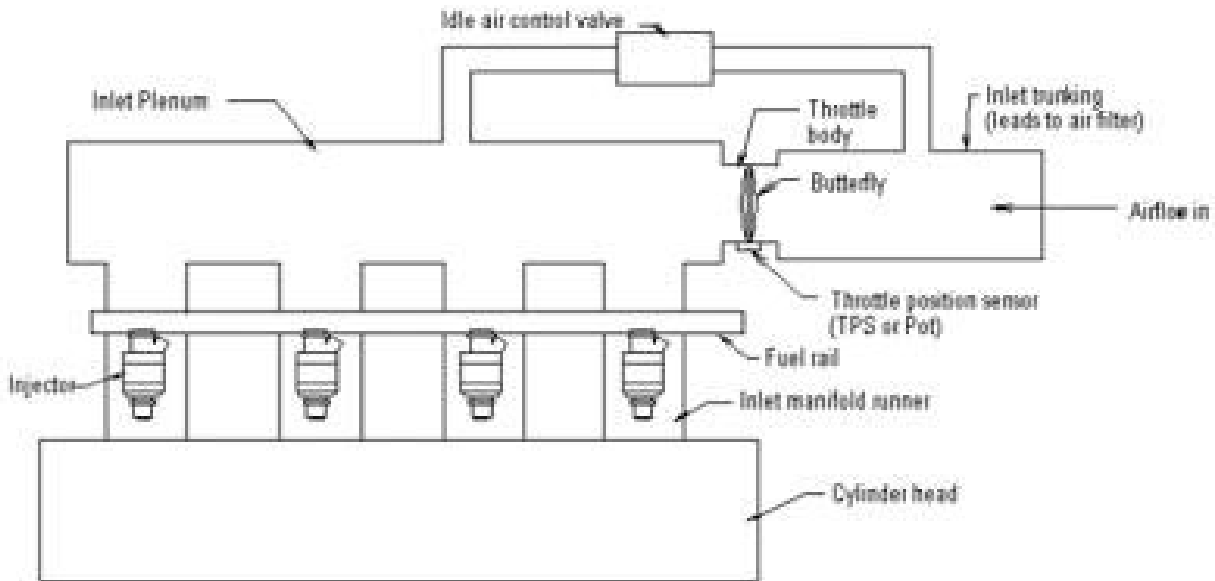
- Ununiform fuel supply to all cylinders.
- Less efficient.
- It wets the intake manifold by forming a layer of fuel on the intake manifold.
- Lower fuel economy.

## Multi Point Fuel Injection System

- In multi-point fuel injection (MPFI) technology, every cylinder in the combustion chamber of the engine is given an injector at the front of their inlet valves (outside the intake port), which is why it's also called 'Port Injection'.
- Every injector sprays fuel at the same time and each cylinder gets a more precise volume of fuel, with less possibility of fuel condensation outside the intake manifold. While MPFI has the advantage of lower fuel wastage as compared to TBI, since the fuel is sprayed at the same time in all the cylinders, it doesn't get properly synced with the rotation of all the pistons. This results in the fuel idling in the engine and port for as long as 150 milliseconds. All the same, from the performance point of view, the MPFIs function much better as compared to TBIs.



### Multiple point injection with plenum



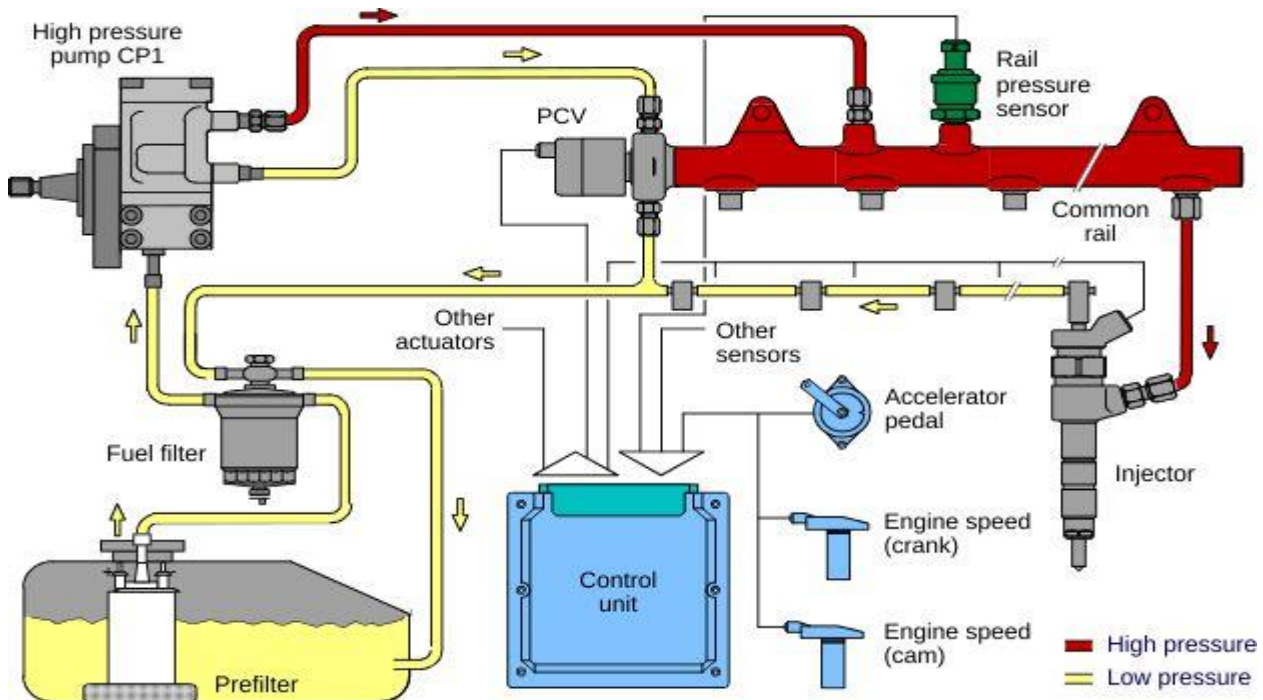
### Advantages

- The system is reliable
- It reduces the difference in power that each cylinder creates.
- It increases the fuel efficiency of an engine
- Better atomization of fuel
- MPFI system have fewer emissions
- Better utilization and distribution of fuel within an engine.
- Better acceleration and deceleration of engine
- It improves the cold start properties of the engine
- Vibrations in reduce in the engine
- Improves durability and functionality of an engine

### Dis Advantages

- Misfiring might occur sometimes
- It requires regular inspection of fuel injectors
- The system is expensive compared to conventional systems.
- Repairing fuel injector can be tedious compared to carburetors
- The system usually has a shorter life.
- ECU failure could occur suddenly.
- A hot engine might be difficult to start due to possible vapor lock in the steel fuel lines above the engine.

## Electronically Controlled Diesel Injection System



The function of the diesel fuel system is to inject a precise amount of atomized and pressurized fuel into each engine cylinder at the proper time. Combustion in a diesel engine occurs when this rush of fuel is mixed with hot compressed air.

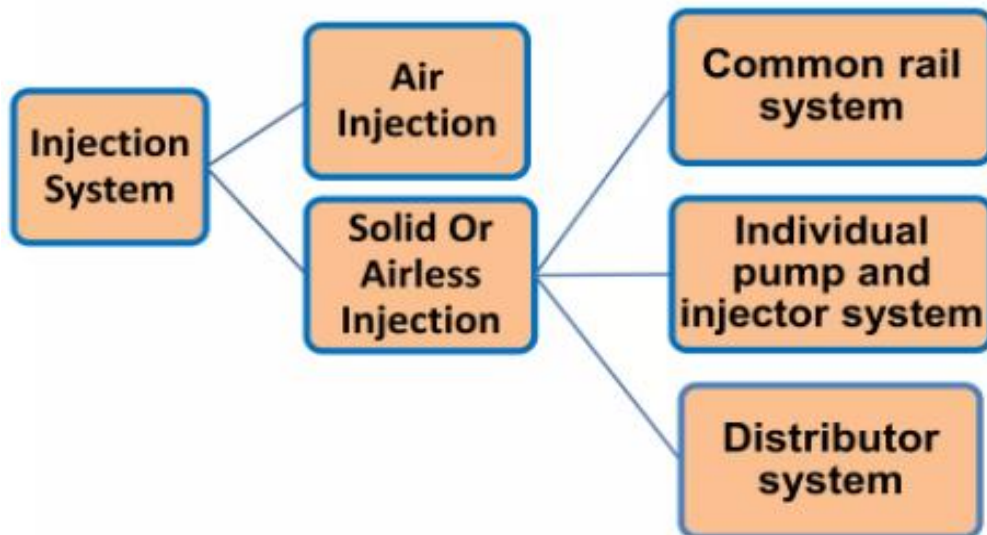
### Parts of Diesel Injection System

- **Fuel Tank:** There are many different types and shapes of fuel tanks. Each size and shape is designed for a specific purpose. The fuel tank must be capable of storing enough fuel to operate the engine for a reasonable length of time. The tank must be closed to prevent contamination by foreign objects. It must also be vented to allow air to enter, replacing any fuel demanded by the engine. Three other tank openings are required--one to fill, one to discharge, and one to drain.
- **Fuel Lines:** There are three types of diesel fuel lines. These include heavyweight lines for the high pressures found between the injection pump and the injectors, medium weight lines for the light or medium fuel pressures found between the fuel tank and injection pump, and lightweight lines where there is little or no pressure.
- **Fuel Filters:** Diesel fuel must be filtered not once, but several times in most systems. A typical system might have three stages of progressive filters--a filter screen at the tank or transfer pump, a primary fuel filter, and a secondary fuel filter. In series filters, all the fuel goes through one filter and then through the other. In parallel filters, part of the fuel goes through each filter.
- **Fuel Transfer Pump:** Simple fuel systems use gravity or air pressure to get fuel from the tank to the injection pump. On modern high-speed diesel engines, a fuel transfer pump is normally used. This pump, driven by the engine, supplies fuel automatically to the diesel injection system. The pump often has a hand primer lever for bleeding air from the system. Modern injection pumps are almost all jerk pumps that use the plunger and cam method of fuel injection.
- **Fuel Injection Systems:** There are four primary systems for injecting fuel:
  1. Individual pump and injector for each cylinder
  2. Combined pump and injector for each cylinder (*unit injector type*)
  3. One pump serving injectors for several cylinders (*distributor type*)

4. Pumps in a common housing with injectors for each cylinder (*common rail system*)

- The common rail system is rapidly gaining popularity for on-road applications. The in-line and distributor types are used on off-road vehicles and industrial machines.
- **Fuel Injector:** Diesel fuel injectors are arguably the most important fuel system component. The job of the injectors is to deliver a precise amount of atomized and pressurized fuel into each cylinder. Highly atomized, pressurized fuel distributed evenly throughout the cylinder results in increased power and fuel economy, decreased engine noise, and smoother operation.

#### Classification of Diesel Injector System



#### Air Injection system

- In this system fuel is injected along with high pressure air into combustion chamber. The pressure of this air is about 70 bar. A multistage air compressor is required to supply the blast of air at high pressures. A fuel pump draws fuel from fuel tank through a filter and discharge a definite quantity into an injector. The high pressure air from compressor is also led to the injector valve which force the fuel, through the nozzle, when it is opened mechanically.
- This type of system is not used now-a-days in diesel engines.

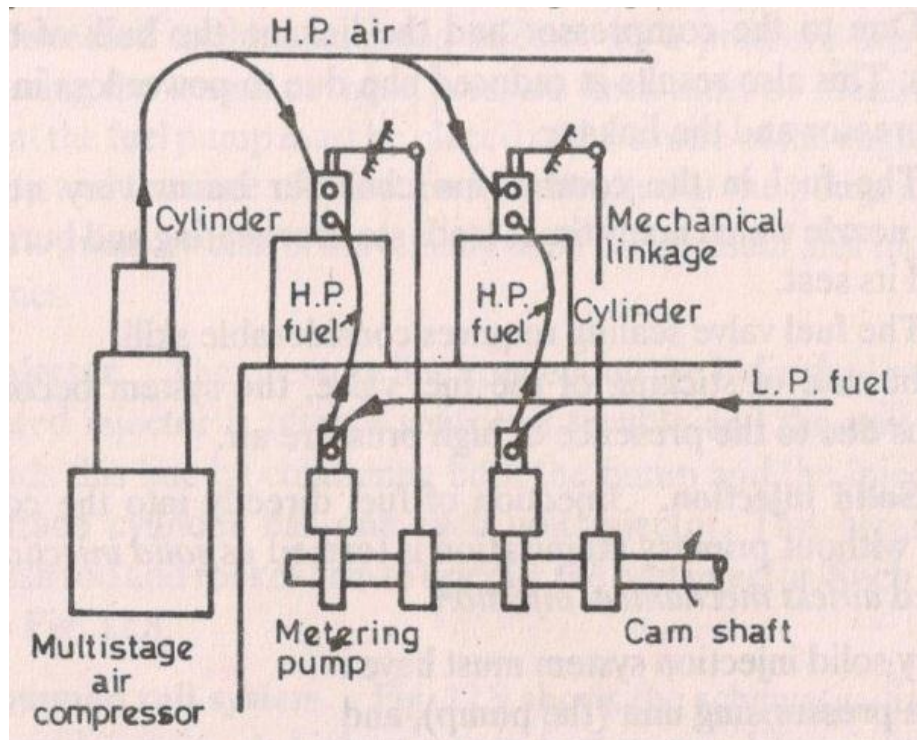


Figure: Air Injection system

**Advantages:**

1. It provides good atomization and distribution of fuel
2. Fuel pump needs to develop less pressure.

**Dis Advantages:**

1. It requires high multi stage compressor.
2. Air Compressor needs extra maintenance.

**Solid or Airless Injection System**

- In solid Injection system , fuel is directly injected into the cylinder without aid of compressed air. That's why this system is called solid or airless injection system.
- Fuel is supplied at very high pressure (about 200 bar) from fuel pump to fuel injector from where it is injected to the combustion chamber with the help of injector.
- There are three types as:
  1. Common rail system
  2. Individual pump and injector
  3. Distributor injection system

**Unit Injector System**

- Fill phase: The constant stroke pump element on the way up draws fuel from the supply duct in to the chamber, and as long as electric solenoid valve remains de-energized fuel line is open.

- Spill phase: The pump element is on the way down, and as long as solenoid valve remains de-energized the fuel line is open and fuel flows in through into the return duct.
- Injection phase: The pump element is still on the way down, the solenoid is now energized and fuel line is now closed. The fuel cannot pass back into return duct, and is now compressed by the plunger until pressure exceeds specific "opening" pressure, and the injector nozzle needle lifts, allowing fuel to be injected into the combustion chamber.
- Pressure reduction phase: The plunger is still on its way down, the engine ECU de-energizes the solenoid when required quantity of fuel is delivered, the fuel valve opens, fuel can flow back into return duct, causing pressure drop, which in turn causes the injector nozzle needle to shut, hence no more fuel is injected.

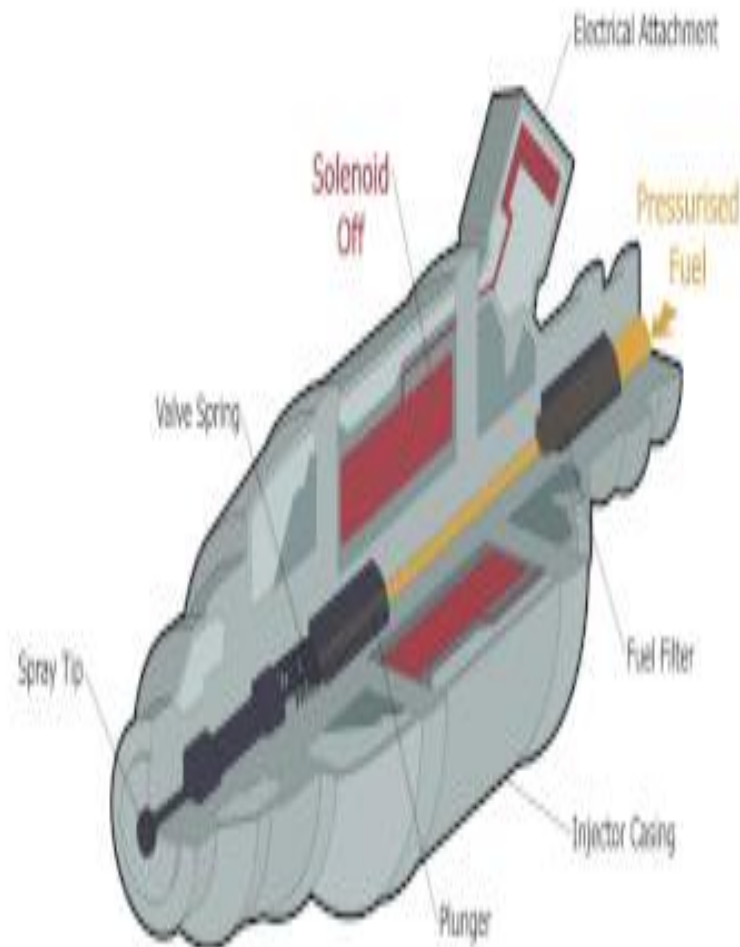


Figure: Unit Injector system

### **Individual Pump and injector (or) Jerk Pump System**

- In this system, each cylinder is provided with one pump and one injector.
- Separate metering and compression pump is provided for each cylinder.
- In high pressure pump , plunger is actuated by a cam & produces the fuel pressure necessary to open the injector valve at the correct time .
- The amount of fuel injected depends on the effective stroke of the plunger.

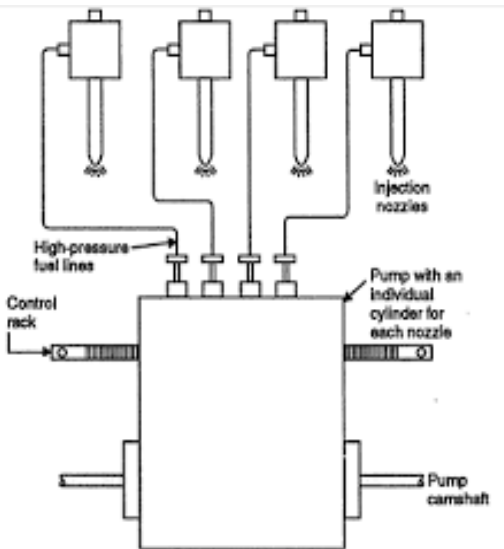


Figure: Individual pump and injector or Jerk Pump System

### Distributor System

- In this system the pump which pressurizes the fuel also meters and times it.
- The fuel pump after metering the required amount of fuel supplies it to a rotating distributor at the correct time for supply to each cylinder.
- The number of injection strokes per cycle for the pump is equal to the number of cylinders used in this system.
- Since there is only one metering element, a uniform distribution is automatically ensured.

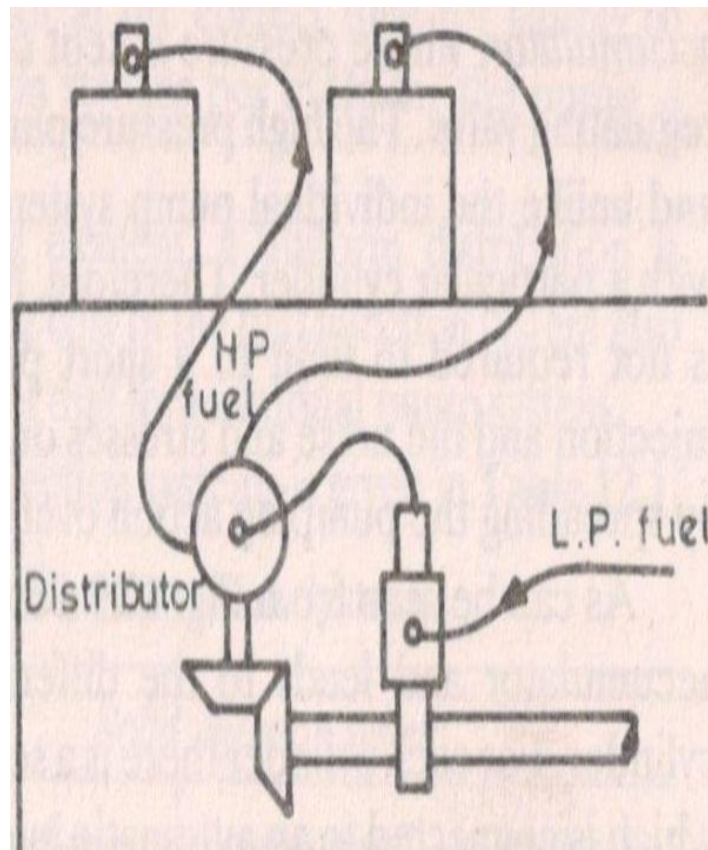
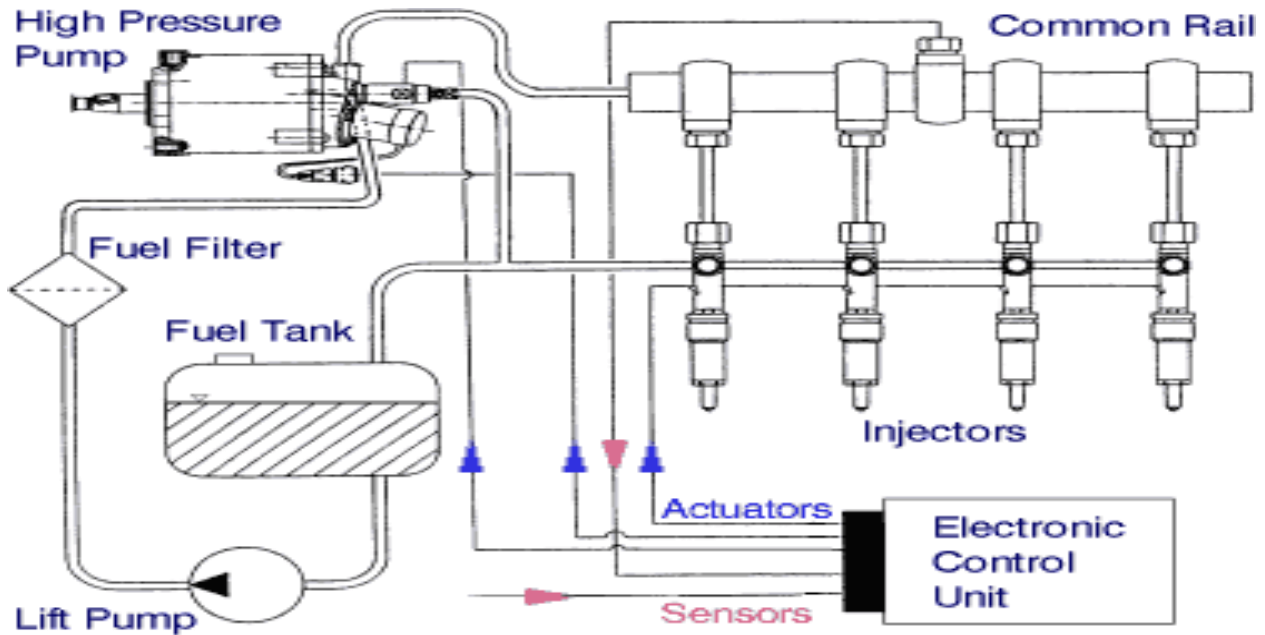


Figure: Distributor system

## Common Rail Injector System



**Figure: Common rail injector system**

- In this system HP pumps supplies fuel, under high pressure, to a header. High pressure in the header forces the fuel to each nozzles located in the cylinders of this system.
- At that time, a mechanically operated valve allows the fuel to enter the proper cylinder through the nozzle.
- By varying the length of the push rod stroke the amount of fuel entering the cylinder is regulated.

### Advantages

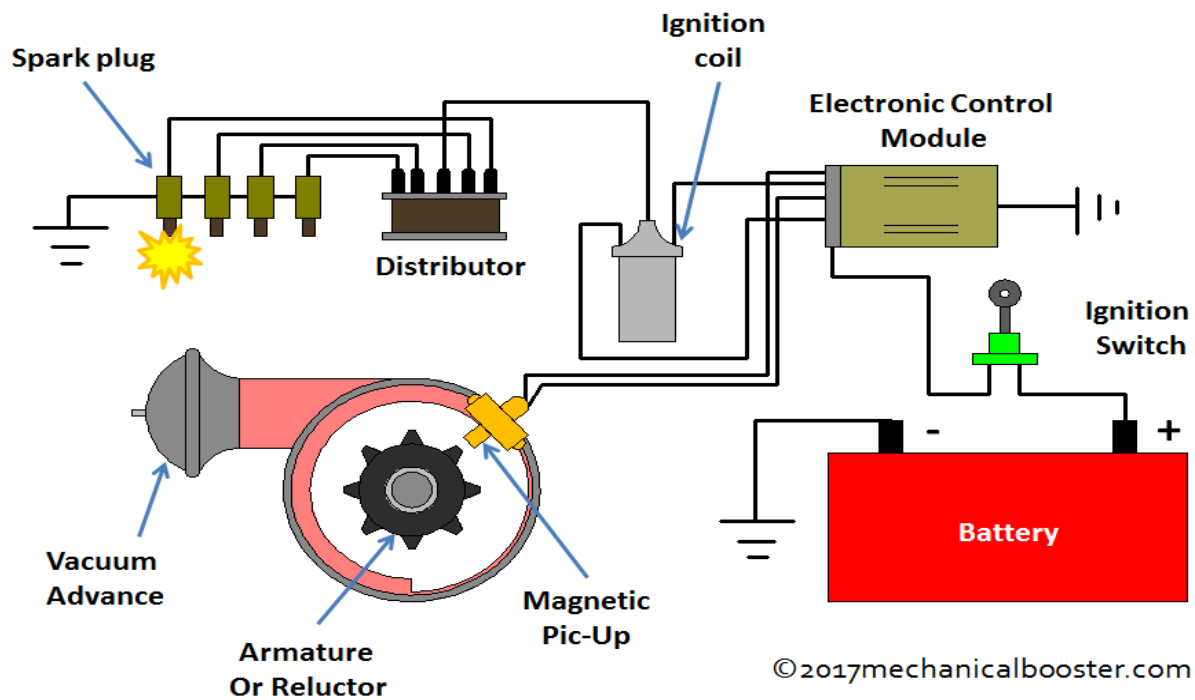
- (i) It delivers 25 % more power and torque than the normal direct injection engine.
- (ii) Initial cost is low.
- (iii) Superior pick up is possible.
- (iv) It maintains lower levels of noise and vibration.
- (v) Higher mileage is obtained.
- (vi) Emissions are low.
- (vii) Fuel consumption is less.
- (viii) Improved performance is obtained.

### Dis Advantages

- (i) Many parts involve the complicated design.
- (ii) Production cost is high.
- (iii) High degree of engine maintenance is required.

## Electronic Ignition System

- An electronic ignition system is a type of ignition system that works electronic circuits, usually by transistors. The transistors are controlled by sensors to generate electric pulses which then generate a high voltage spark that can burn the lean mixture and provide a better economy and lower emission.
- The electronic ignition system is vastly used in aircraft engines, bikes, motorcycles, and cars as it performs the same purpose as other types of ignition systems on them.
- The function of an electronic ignition system is remaining the same as it produces a high voltage spark to the spark plug so that the fuel-air mixture can be burn or ignite. Because sensors are used in the system, it improves reliability and mileage and decreases emission.



**Electronic Ignition System**

### Components of Electronic Ignition System

- Battery
- Ignition Switch
- Electronic Control Module
- Armature
- Ignition Coil
- Distributor
- Spark Plug

### Working Principle of Electronic Ignition system

- When switching on the ignition switch, just after that battery starts and it supplies current to the system.
- Current passes through the ignition switch and move toward the ignition coil on the system then, start passing through the primary winding of the coil.
- As the current passes through the primary coil, the pick-up coil got activated which is in the armature. It receives current as a voltage on the pick-up. Just after receiving voltage, the reluctor starts rotating which consists of the tooth.
- When the tooth comes in front of the pick-up coil exactly at the same time the pick-up coil starts sending a signal to the electronic control module.
- After receiving a voltage signal, it stops the current supply from the battery up to the primary coil. When the tooth deviates from the point, it senses the change in voltage, and then again it sends a signal of change in voltage to the electronic control module.
- We all know that the electronic control system is already a programmed system, so exactly after sending a signal of change in voltage it again starts supplying the current in the primary winding.
- Because of this continuous make and break of the current circuit, it creates a magnetic field inside

the ignition coil because of that; the secondary winding emf is induced.

- This emf increases voltage up to 50000 V. The voltage is supplied to the distributor.
- It consists of a rotating rotor and distributor points, which is programmed as per the ignition. When there is a jump of voltage between the air gap of the rotor and the distributor of high voltage, after that it reaches to spark plug through high tension wire.
- Spark is generated because of the voltage difference between the central electrode and the ground electrode because the combustion is possible in air-fuel.

### Application of Electronic Ignition System:

- The electronic ignition system has a lot of applications in the 21st century.
- It is mostly used in modern and hyper cars.
- It is mostly used in Audi, Mahindra XUV, KTM bikes, Ducati, and many more.
- It is also used in aircraft engines.

### Advantages

- These are low maintenance systems as compared to others like Battery Ignition System, Glow plug ignition system, and Magneto Ignition System.
- It has no moving parts because it is controlled by the electronic control unit(ECV).
- Emission is less as compared to other means because this system is environmentally friendly.
- It increases the efficiency of the engine and also it is fuel-efficient.
- It is more accurate as compared to the magneto system.
- The vehicles having this system have a long life and also reliable.

### Dis Advantages

- The cost of the system is very expensive

### Transistorised Coil Ignition System

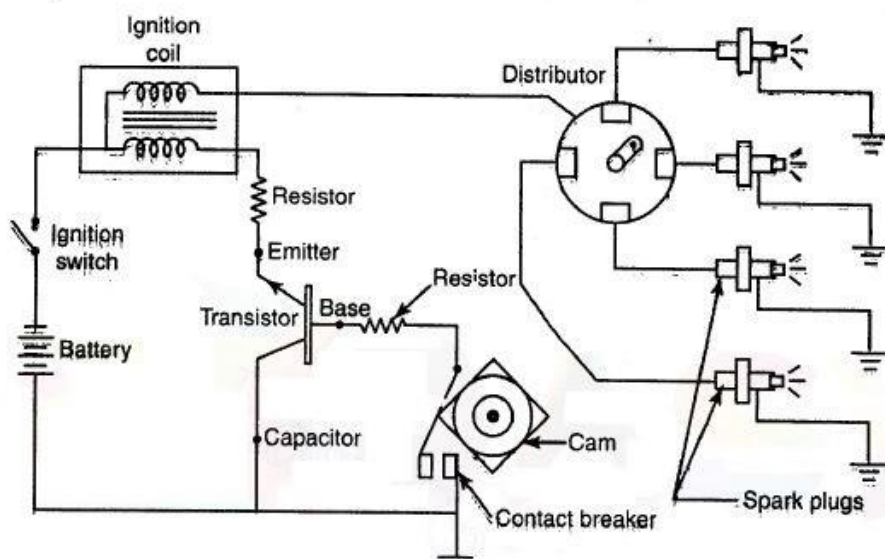


Figure: Transistorised Coil Ignition System

## **Components of Transistorised Coil Ignition System**

- Battery
- Ignition Switch
- Ignition Coil
- Transistor
- Collector
- Emitter
- Blast resistor
- Contact breaker
- Distributor
- Spark Plug

## **Working Principle of Transistorised Coil Ignition System**

- The cam in the distributor is rotated by the engine. It opens and closes the contact breaker points.

When the contact breaker points are closed:

1. A small current flows in the base circuit of the transistor.
2. A large current flows in the emitter or collector circuit of the transistor and the primary winding of the Ignition coil due to the normal transistor action.
3. A magnetic field is set up in the primary winding of the coil.

When the contact breaker points are Open :

1. The current flow in the base circuit is stopped.
2. The primary current and the magnetic field in the coil collapse suddenly due to immediate reverting of the transistor to the non-conductive state.
3. It produces a high voltage in the secondary circuit.
4. This high voltage is directed to the respective spark plugs through the rotor of the distributor.
5. This high voltage produces a spark when it is tried to jump the spark plug gap. It ignites air-fuel mixture in the cylinder.

## **Advantages**

- It increases the life of contact breaker points.
- It gives high ignition voltages.
- It gives longer duration of spark .
- It has very accurate control of timing.
- It needs less maintenance.

## **Dis Advantages**

- More mechanical points are needed similar to a conventional system.
- It has a tendency to side tracking.

## Capacitive Discharge Ignition System

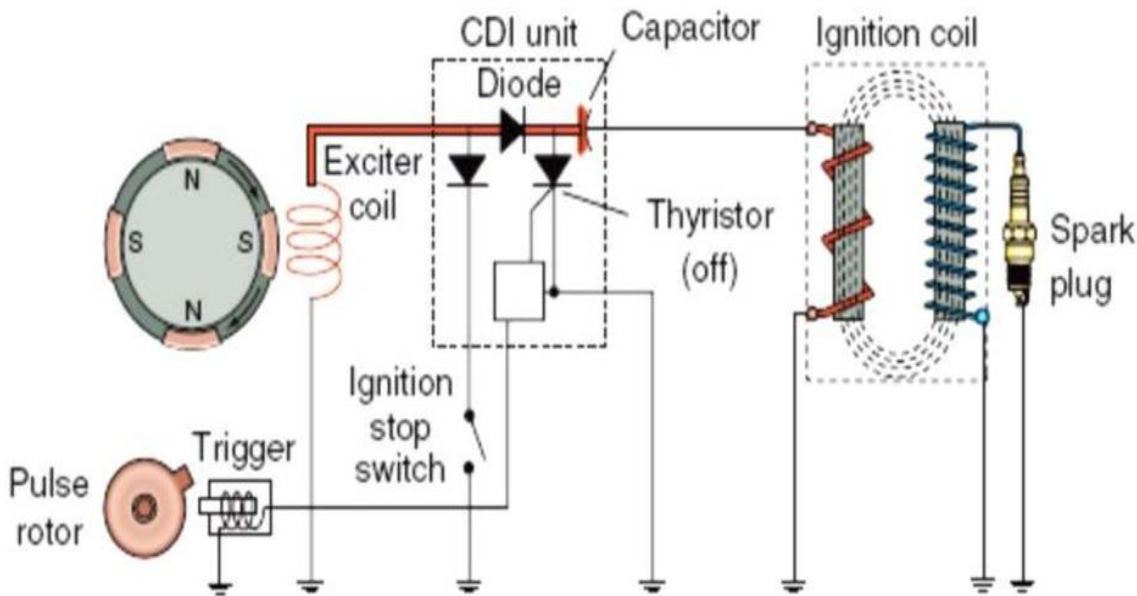


Figure: Capacitive Discharge Ignition System

### Working principle

- The CDI system consists of two coils that are triggered by the magnets in the flywheel/rotor, the larger coil is called as charging or Exciter coil and the smaller coil is called as Trigger coil.
- As the flywheel rotates past the exciter coil, the AC produced by the exciter coil is changed to DC by the diode in the CDI unit.
- The capacitor in CDI unit stores the energy until its needed to fire the spark plug.
- As the flywheel/rotor magnet rotates past the trigger coil, a low voltage in the trigger coil, which activates the electronic switch in CDI unit.
- The electronic switch acts as power source to the primary side of the circuit, this completed primary circuit which allows the energy stored by the capacitor to pass through the primary winding of the ignition coil.
- The transformer action of the ignition coil causes high voltage to be induced in the secondary winding of the ignition coil, which fires the spark plug.

### Advantages of the CDI system:

- Insensitive to electrical shunts resulting from spark plug fouling.
- This system is suited to an application where insufficient dwell time is available because the capacitor can be fully charged in a very short time.
- Short transient response.
- A fast voltage rise and shorter spark duration.

### Disadvantages of the CDI system:

- The spark is strong but short in order to 0.1 to 0.3 ms which leads to ignition failure during lean mixture operating conditions because of fast capacitive discharge.
- This system generates a huge electro-magnetic noise so CDI is rarely used by automobile manufacturers.

# Turbo Chargers

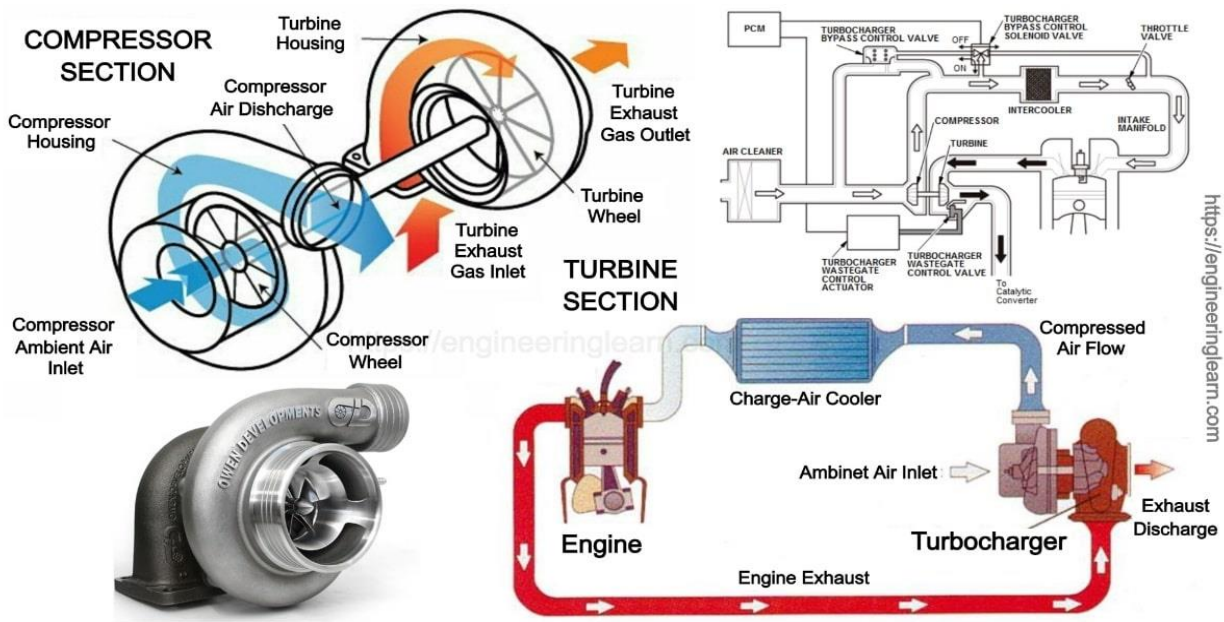


Figure: Working and Line diagram of turbo charger

- The turbo charger utilizes the wasted heat energy in the exhaust system, to run a compressor which compresses the intake air. Compressed intake air has more density and hence more fuel can be injected increasing the power of the engine. Turbo charging is an ideal way to increase the engine power without increasing the engine size.
- It is a turbine-driven forced induction device that increases an engine's efficiency and power by forcing extra air into the combustion chamber. This improvement over a naturally aspirated engine's output results because the turbine can force more air, and proportionately more fuel, into the combustion chamber than atmospheric pressure alone.
- Turbochargers are commonly used on truck, car, train, aircraft, and construction equipment engines. They are most often used with Otto cycle and Diesel cycle internal combustion engines. They have also been found useful in automotive fuel cells.

## Waste Gate Turbo Charger (WGT)

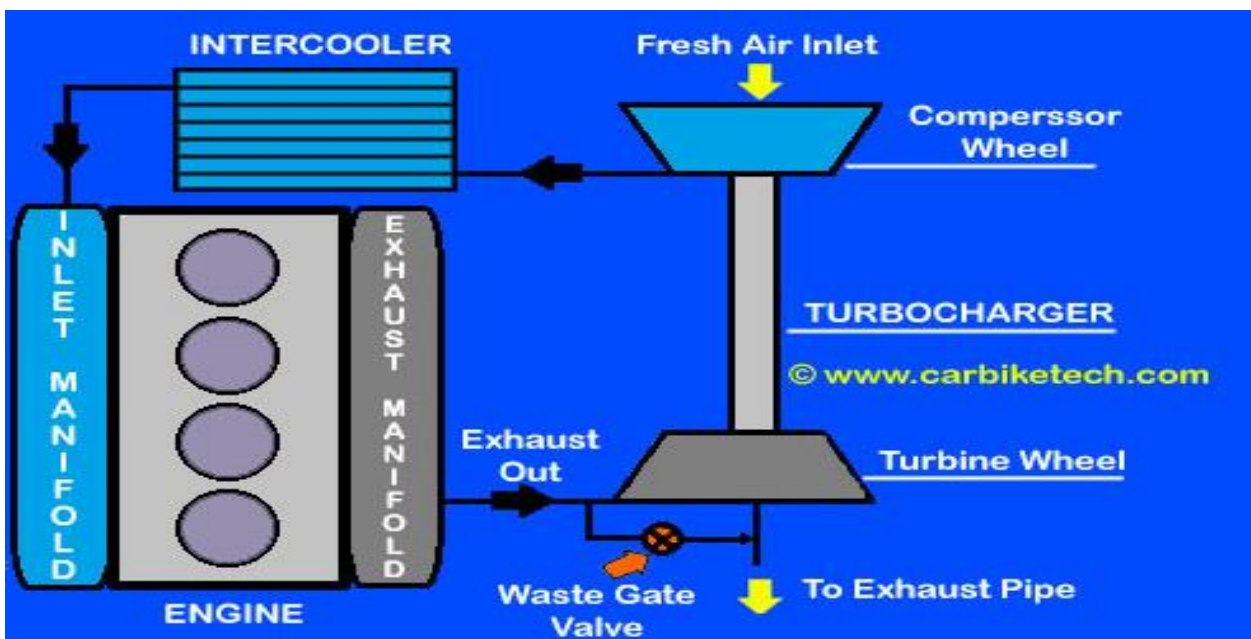


Figure: Waste Gate Turbo Charger

The waste-gate regulates the pressure of the relief valve. It, in turn, limits the boost pressure in the turbocharger system. This is helpful in preventing the engine from potential mechanical damages caused by the high pressure. Furthermore, the system automatically opens the waste-gate valve when the pressure reaches the pre-set levels. Then, it allows all the high-pressure exhaust gases to escape the turbine wheel and enter into the downstream/outlet. Thus, it prevents the exhaust gas pressure from rising more than required.

### Advantages

- Needs a smaller space to fit.
- Reduces turbo lag to some extent.
- Installation of compact and simple external exhaust pipe system. Thus, reducing the engine weight.
- Delivers optimum engine performance at all times.
- Avoids mechanical damage to engine parts

### Variable Geometry Turbo charger (VGT)

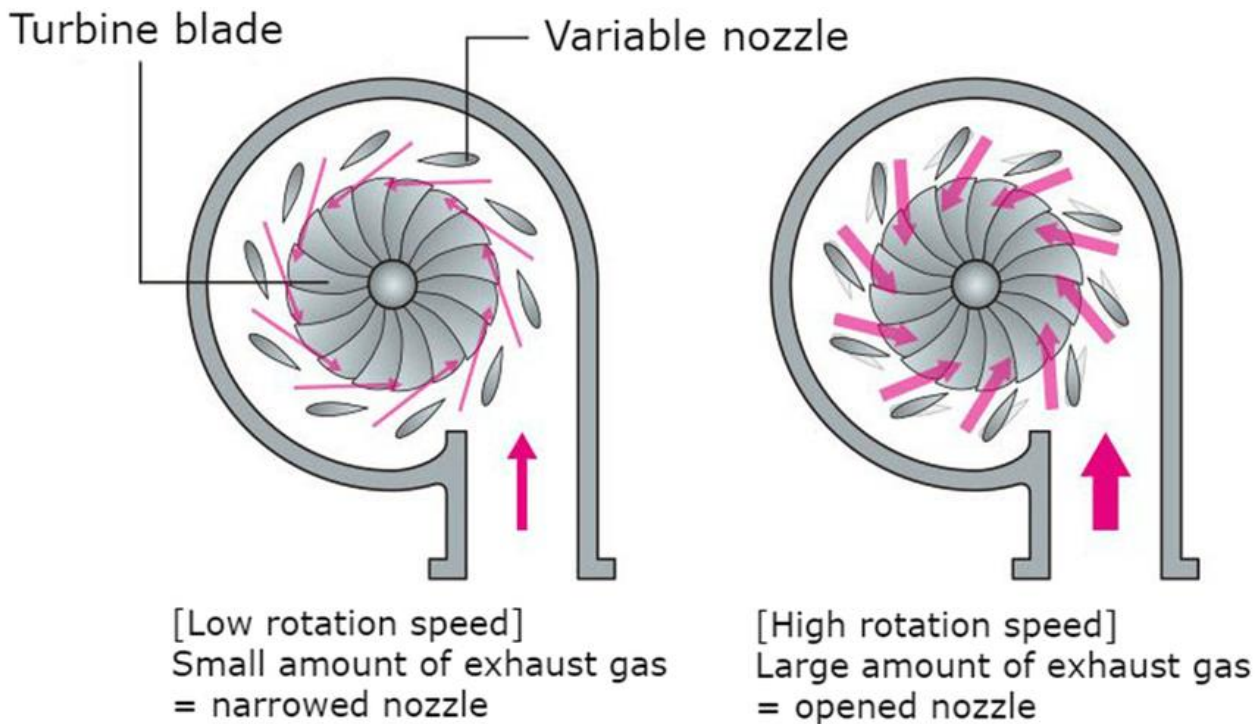


Figure: Variable Gate Turbocharger (VGT)

- VGTs refer to those types of turbochargers which include a ring of aerodynamically-shaped vanes inside the turbine housing at the turbine inlet. The turbos used in the passenger cars and light commercial vehicles, can rotate in order to vary the gas swirl angle and the cross-sectional area simultaneously. The internal vanes which are present alter the turbos area-to-radius ratio (A/R) in order to match the RPM of the engines, and to also give a peak performance.
- Considering a case of low RPM, a low A/R ratio occurs which helps the turbo to spool up quickly by increasing the velocity of the exhaust gas. At higher revs the A/R ratio increases which is responsible for the increased airflow. These results in a low boost threshold which is responsible for reducing the turbo lag, and also provides a wide and smooth torque band.
- While the VGTs are quite typically used in the diesel engines where the exhaust gases lower the temperature and by then the VGTs were just limited in the petrol engine applications due to their cost and the requirement for components was made from an exotic material.

## **Types of nozzles:**

(a) Depends on the type of combustion chamber,

### **Open combustion chamber:**

- fuel seeks air
- air swirl is created due to inclined induction port
- multi-hole nozzle injects fuel at a pressure of about 200 to 300 bar to slow moving air
- provide good cold starting performance and improved thermal efficiency

### **Pre-combustion chamber:**

- air velocity is very much high
- single hole nozzle with 65 to 100 bar injection pressure is used
- used in high speed engine due to rapid combustion
- external heating device for easy starting of the engine

(b) Open and closed type of nozzle,

#### **Open type:**

- consists of fuel orifices and open to burner
  - cheap and less efficient
- ex- opposed piston two-stroke Junkers diesel engine

**Closed type:** pressure drop is minimised compared to open type

(c) Different types of nozzle for different combustion chamber

#### (i) **Single hole nozzle:**

- used in open combustion chamber
- size of hole larger than 0.2 mm
- very high injection pressure required

#### (ii) **Multi-hole nozzle:**

- no. of hole varies from 4 to 18 and the size from 1.5 to 0.35 mm
- injection rate is not uniform

#### (iii) **Pintle nozzle:**

- a projection or pintle is provided in the nozzle to avoid weak injection and dribbling
- pintle may be cylindrical or conical shape



- cone angle varied from 0 to 60°
- provide good atomisation and reduced penetration
- fuel pressures are lower than single and multi-hole nozzle

(iv) **Pintaux nozzle:**

- injected fuel in upstream of air
- development of pintle nozzle with auxiliary hole drilled in the nozzle body
- reduced delay period and increased thermal efficiency

## CATALYTIC CONVERTER

As indicated by the meaning of chemistry, a catalyst is a substance that causes or quickens a compound response without itself being influenced. Catalysts take an interest in the responses, however are neither reactants nor results of the response they catalyze. An exhaust system is a vehicle discharges control gadget which changes over lethal by-results of burning in the fumes of an interior ignition motor to less poisonous substances by method for catalyzed compound responses . It lessens temperature at which CO and HC change over into CO<sub>2</sub> and H<sub>2</sub>O. Big and large exhaust systems utilize platinum gathering of respectable metals.

The contaminations have negative effect on air quality, environment and human wellbeing that leads instrigent standards of poison outflow. Quantities of option innovations like change in motor plan, fuelpretreatment, utilization of option energizes, fuel added substances, fumes treatment or better tuning of the ignition procedure and so forth, are being considered to lower the release levels of the engine. Out of various progressions available for auto vapor radiation control a fumes framework is found to best choice to control CO, HC and NO<sub>x</sub> discharges from petrol driven vehicles while diesel particulate channel and oxidation forces converter or diesel oxidation impulse have so far been the most potential other option to control particulates outpourings from diesel driven vehicle [5]. An exhaust system (CC) is put inside the tailpipe through which destructive fumes gasses containing unburnt fuel, CO, NO<sub>x</sub> are transmitted .

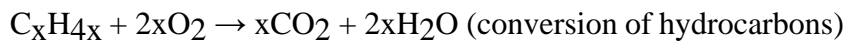
### Three-way Catalytic Converter

Similar to the oxidation converter, the reduction catalytic converter helps to eliminate hydrocarbons and carbon-monoxide emanations, in addition to oxides of nitrogen discharges, or NO<sub>x</sub>. NO<sub>x</sub> outflows are created in the motor burning chamber when it reaches extremely high temperatures more than 2,500 degrees Fahrenheit, approximately. In this type of converter, a reduction reaction also occurs in addition to two oxidation reactions same as two-way converter. The reduction reaction occurs during the conversion of



oxides of nitrogen to nitrogen and oxygen. So this type of converter is also known as reduction type catalytic converter.

#### Conversion Reactions in Three Way Catalytic Converter



#### Emissions

- Emission Norms are emission standards instituted by the Government of a nation to regulate the output of air pollutants from internal combustion engines and Spark-ignition engines equipment, including motor vehicles.
- In India the standards and the timeline for implementation are set by the Central Pollution Control Board under the Ministry of Environment, Forest and Climate Change
- All new vehicles manufactured after the implementation of the norms have to be compliant with the regulations



# European Emission Standards

- **European emission standards** define the acceptable limits for exhaust emissions of new vehicles sold in EU member states.
- Currently, emissions of nitrogen oxides (NO<sub>x</sub>), total hydrocarbon (THC), non-methane hydrocarbons (NMHC), carbon monoxide (CO) and particulate matter (PM) are regulated for most vehicle types, including cars, lorries, trains, tractors and similar machinery, but excluding seagoing ships and aeroplanes.
- For each vehicle type, different standards apply. Compliance is determined by running the engine at a standardised test cycle. Non-compliant vehicles cannot be sold in the EU, but new standards do not apply to vehicles already on the roads. **No use of specific technologies is mandated to meet the standards, though available technology is considered when setting the standards.** New models introduced must meet current or planned standards,

## CO<sub>2</sub> emission

- Within the European Union, road transport is responsible for about 20% of all CO<sub>2</sub> emissions, with passenger cars contributing about 12%.
- The target fixed at Kyoto Protocol was an 8% reduction of emissions in all sectors of the economy compared to 1990 levels by 2008-2012.
- Relative CO<sub>2</sub> emissions from transport have risen rapidly in recent years, from 21% of the total in 1990 to 28% in 2004,

European emission standards for **passenger cars** (Category M\*), g/km

Tier	Date	CO	THC	NMHC	NO <sub>x</sub>	HC+NO <sub>x</sub>	PM	P***
<b>Diesel</b>								
Euro 1†	July 1992	2.72 (3.16)	-	-	-	0.97 (1.13)	0.14 (0.18)	-
Euro 2	January 1996	1.0	-	-	-	0.7	0.08	-
Euro 3	January 2000	0.64	-	-	0.50	0.56	0.05	-
Euro 4	January 2005	0.50	-	-	0.25	0.30	0.025	-
Euro 5	September 2009	0.50	-	-	0.180	0.230	0.005	-
Euro 6 (future)	September 2014	0.50	-	-	0.080	0.170	0.005	-
<b>Petrol (Gasoline)</b>								
Euro 1†	July 1992	2.72 (3.16)	-	-	-	0.97 (1.13)	-	-
Euro 2	January 1996	2.2	-	-	-	0.5	-	-
Euro 3	January 2000	2.3	0.20	-	0.15	-	-	-
Euro 4	January 2005	1.0	0.10	-	0.08	-	-	-
Euro 5	September 2009	1.0	0.10	0.068	0.060	-	0.005**	-
Euro 6 (future)	September 2014	1.0	0.10	0.068	0.060	-	0.005**	-
* Before Euro 5, passenger vehicles > 2500 kg were type approved as <b>light commercial vehicles</b> N <sub>1</sub> -I								
** Applies only to vehicles with direct injection engines								
*** A number standard is to be defined as soon as possible and at the latest upon entry into force of Euro 6								
† Values in brackets are <b>conformity of production (COP)</b> limits								



## Emission standards for light commercial vehicles

European emission standards for **light commercial vehicles** ≤1305 kg (Category N<sub>1</sub>-I), g/km

Tier	Date	CO	THC	NMHC	NO <sub>x</sub>	HC+NO <sub>x</sub>	PM	P
<b>Diesel</b>								
Euro 1	October 1994	2.72	-	-	-	0.97	0.14	-
Euro 2	January 1998	1.0	-	-	-	0.7	0.08	-
Euro 3	January 2000	0.64	-	-	0.50	0.56	0.05	-
Euro 4	January 2005	0.50	-	-	0.25	0.30	0.025	-
Euro 5	September 2009	0.500	-	-	0.180	0.230	0.005	-
Euro 6	September 2014	0.500	-	-	0.080	0.170	0.005	-
<b>Petrol (Gasoline)</b>								
Euro 1	October 1994	2.72	-	-	-	0.97	-	-
Euro 2	January 1998	2.2	-	-	-	0.5	-	-
Euro 3	January 2000	2.3	0.20	-	0.15	-	-	-
Euro 4	January 2005	1.0	0.10	-	0.08	-	-	-
Euro 5	September 2009	1.000	0.100	0.068	0.060	-	0.005*	-
Euro 6	September 2014	1.000	0.100	0.068	0.060	-	0.005*	-

\* Applies only to vehicles with direct injection engines

## History of Emission Standards in India

- It was in the early nineties that the first emission standards were introduced in the country.
- Other regulatory norms followed in the form of making the catalytic converters mandatory for petrol vehicles and then, by the introduction of unleaded petrol.
- In 1999, the apex court of the country made it mandatory for all vehicles to meet the India 2000 norms by June 2000, in a ruling.
- In 2002, the Mashelkar Committee report was accepted by the Indian Government.
  - The committee had recommended a roadmap for the implementation of the Euro norms based emission standards for India.
  - It also recommended that the roll-out of the norms be implemented in major cities first to be followed by the rest of the country in a phased manner.
  - Based on the committee's recommendations, in 2003, the government released the National Auto Fuel Policy.

## Bharat Stage Emission Standards

- Bharat Stage or BS Emission Standards are government-instituted emission standards that all motor vehicles have to comply with if they are to be sold and driven in India.
- Currently, all new vehicles sold and registered in India should be compliant with the BS-VI iteration of emission standards.
- The standards and timelines for their implementation are set by the Central Pollution Control Board (CPCB) under the Minister of Environment, Forests and Climate Change.
- The BS norms are based on the European Emission Standards (Euro norms) and were first set in 2000. Equivalent to the Euro-1, the first iteration was known as 'India 2000', and not BS-I.
- Subsequent emission standards were called BS-II, BS-III, and BS-IV.
- The government decided to jump directly from BS-IV to BS-VI skipping BS-V in view of the long time it took to move from BS-III to IV.



- With the implementation of the new norms, pollution levels are expected to reduce to a large extent as the particulate matter (PM) concentration should decrease. About one-third of the air pollution is caused by motor vehicles and cars.
- At present, BS-IV auto fuels are being supplied in over 30 cities, and the rest of the country has BS-III fuels.
- Earlier, the government planned the implementation of BS V and BS VI emission norms nationwide by 2020 and 2024 respectively. However, the government decided to advance the dates.

The following table gives the timeline of the BS norms being implemented in India starting from the India 2000 till the latest BS-VI norms.

<b>Standard (Reference)</b>	<b>Year/Region</b>
<b>India 2000 (Euro 1)</b>	<b>2000 – Nationwide</b>
<b>BS II (Euro 2)</b>	<b>2001 – Metro cities</b> <b>2003 – 10 more major cities</b> <b>2005 – Nationwide</b>
<b>BS III (Euro 3)</b>	<b>2005 – Metros and major cities</b> <b>2010 – Nationwide</b>
<b>BS V (Euro 5)</b>	<b>Skipped</b>
<b>BS VI (Euro 6)</b>	<b>2018 – Delhi</b> <b>2019 – NCR</b> <b>2020 – Nationwide</b>





---

# UNIT III

# TRANSMISSION SYSTEMS

---



## UNIT-III

### TRANSMISSION SYSTEMS

#### Introduction to the Transmission Systems in Automobile:

It is a system by means of which power developed by the engine is transmitted to the road wheels to propel the vehicle.

Chief function of the device is to receive power at one torque and angular velocity and to deliver it at another torque and the corresponding angular velocity.

#### REQUIREMENTS OF TRANSMISSION SYSTEM

1. To provide for disconnecting the engine from the driving wheels.
2. When the engine is running, to enable the connection to the driving wheels to be made smoothly and without shock.
3. To enable the leverage between the engine and driving wheels to be varied.
4. It must reduce the drive-line speed from that of the engine to that of the driving wheels in a ratio of somewhere between about 3:1 and 10:1 or more, according to the relative size of engine and weight of vehicle.
5. Turn the drive, if necessary, through 90° or perhaps otherwise re-align it.
6. Enable the driving wheels to rotate at different speeds.
7. Provide for relative movement between the engine and driving wheels.

**The most common transmission systems that have been used for the automotive industry are:**

- Manual transmission,
- Automatic transmission,
- Semi-automatic transmission,



- Continuously-variable transmission (C.V.T.).

### **Manual Transmission:**

The first transmission invented was the manual transmission system. The driver needs to disengage the clutch to disconnect the power from the engine first, select the target gear, and engage the clutch again to perform the gear change. This will challenge a new driver. It always takes time for a new driver to get used to this skill.

### **Automatic Transmission:**

An automatic transmission uses a fluid-coupling torque converter to replace the clutch to avoid engaging/disengaging clutch during gear change. A completed gear set, called planetary gears, is used to perform gear ratio change instead of selecting gear manually. A driver no longer needs to worry about gear selection during driving. It makes driving a car much easier, especially for a disabled or new driver. However, the indirect gear contact of the torque converter causes power loss during power transmission, and the complicated planetary gear structure makes the transmission heavy and easily broken.

### **Semi-Automatic Transmission:**

A semi-automatic transmission tries to combine the advantages of the manual and automatic transmission systems, but avoid their disadvantages. However, the complicated design of the semi-automatic transmission is still under development, and the price is not cheap. It is only used for some luxury or sports cars currently.

### **Continuously Variable Transmission (C.V.T.):-**

The Continuously Variable Transmission (C.V.T.) is a transmission in which the ratio of the rotational speeds of two shafts, as the input shaft and output shaft of a vehicle or other machine, can be varied continuously within a given range, providing an infinite number of possible ratios. The other mechanical transmissions described above only allow a few different gear ratios to be selected,

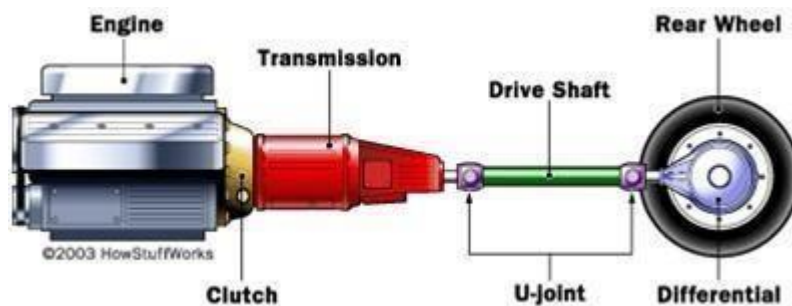


but this type of transmission essentially has an infinite number of ratios available within a finite range.

It provides even better fuel economy if the engine is constantly made run at a single speed. This transmission is capable of a better user experience, without the rise and fall in speed of an engine, and the jerk felt when changing gears.

## MANUAL TRANSMISSION SYSTEM

Manual transmissions also referred as stick shift transmission or just 'stick', 'straight drive', or standard transmission because you need to use the transmission stick every time you change the gears. To perform the gear shift, the transmission system must first be disengaged from the engine. After the target gear is selected, the transmission and engine are engaged with each other again to perform the power transmission. Manual transmissions are characterized by gear ratios that are selectable by locking selected gear pairs to the output shaft inside the transmission.



**Fig: The transmission system delivers the engine power to wheels.**



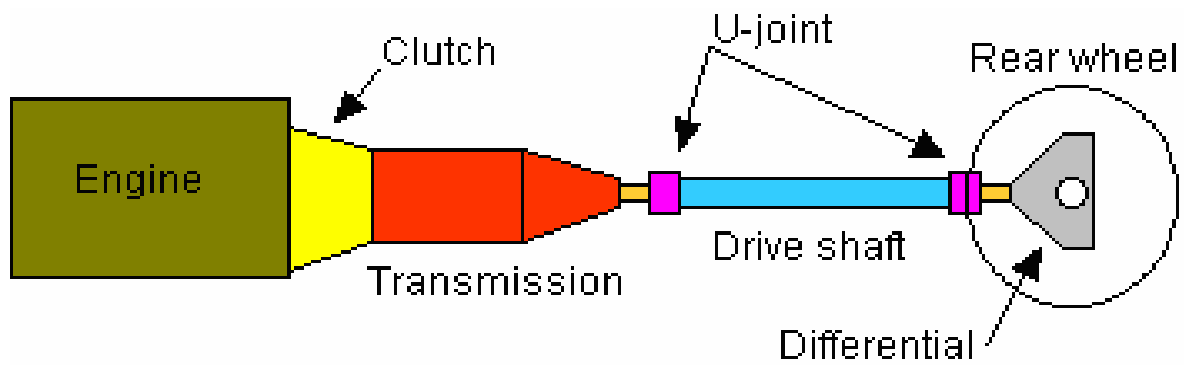


Fig: Layout of Automobile Power Transmission System

## Components of manual transmission

The main components of manual transmission are:

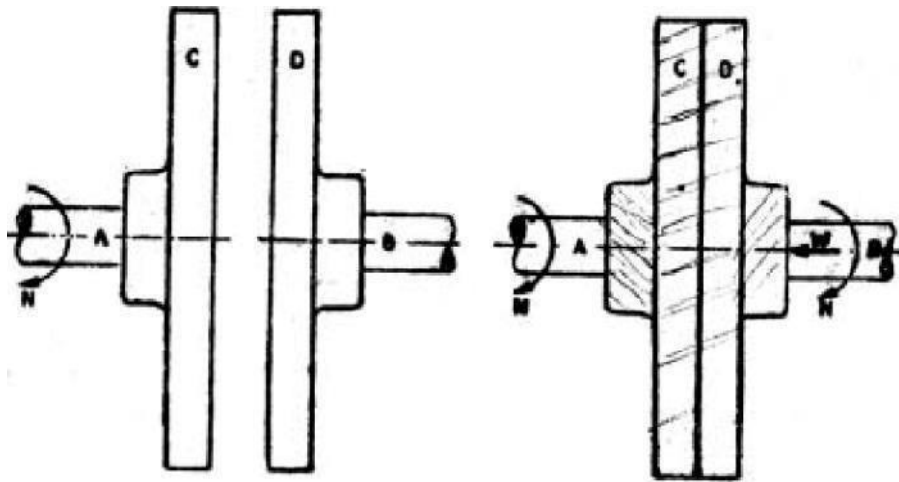
- Clutch
- Gear box
- Slip joint
- Universal joint
- Propeller shaft
- Final drive
- Differential unit
- Rear axle

### **Clutch:**

Clutch is a device which is used in the transmission system of automobile to engage and disengage the engine to the transmission or gear box. It is located between the transmission and the engine. When the clutch is engaged, the power flows from the engine to the rear wheels in a rear-wheel-drive transmission and the vehicle moves. When the clutch is disengaged, the power is not transmitted from the engine to the rear wheels and vehicle stops even if engine is running.



It works on the principle of friction. When two friction surfaces are brought in contact with each other and they are united due to the friction between them. If one is revolved the other will also revolve.



*Fig: Principle of Clutch*

The friction depends upon the surface area contact. The friction surfaces are so designed that the driven member initially slips on driving member when initially pressure is applied. As pressure increases the driven member is brought gradually to speed the driving member.

### **The three main parts of clutch are:**

- Driving member
- Driven member
- Operating member

The driving member consists of a flywheel mounted on the engine crank shaft. The flywheel is bolted to cover which carries a pressure plate or driving disc, pressure springs and releasing levers. Thus the entire assembly of flywheel and cover rotates all the times. The clutch housing and the cover provided with openings dissipate the heat generated by friction during the clutch operation.

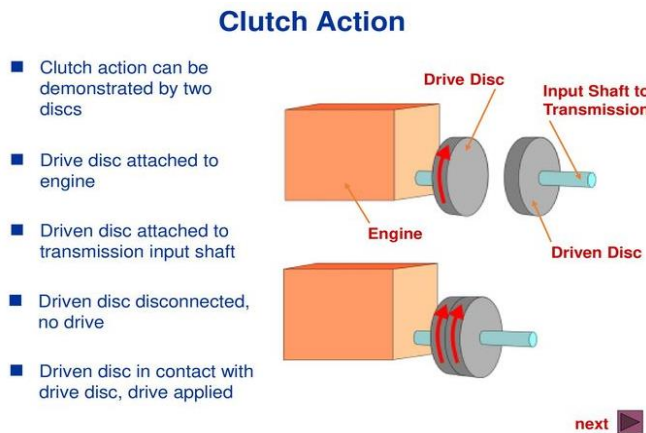
The driving member consists of a disc or plate called clutch plate. It is free to slide length wise on the splines of the clutch shaft. It carries friction materials on both of its surfaces when it is gripped



between the flywheel and the pressure plate; it rotates the clutch shaft through splines.

The operating members consists of a foot pedal, linkage, release or throw-out bearing, release levers and springs necessary to ensure the proper operation of the clutch.

Now the driving member in an automobile is flywheel mounted on crank shaft, the driven member is the pressure plate mounted on transmission or gear box input shaft. Friction surfaces or clutch plates is placed between two members.



### Properties of Good Clutching:

- Good Wearing Properties
- High Resistance to heat
- High coefficient of friction
- Good Binders in it

### Functions of Clutch

1. It permits smooth engagement and disengagement to select gear when the vehicle is stationary and the engine is running.
2. It transmits engine power to driving wheels without jerk while the vehicle is in motion.
3. It permits the change of gear when vehicle is in motion.

### Operation of Clutch:

When the clutch pedal is pressed through pedal movement, the clutch release bearing presses on the clutch release lever plate which being connected to clutch release levers, forces these levers forward. This causes the pressure plate to compress pressure springs, thus allowing it to move away from the clutch driven plate. This action releases the pressure on the driven plate and flywheel, the flywheel is now free to turn independently, without turning the transmission.

When the clutch pedal is released, reverse action takes place i.e. the driven plate is again forced



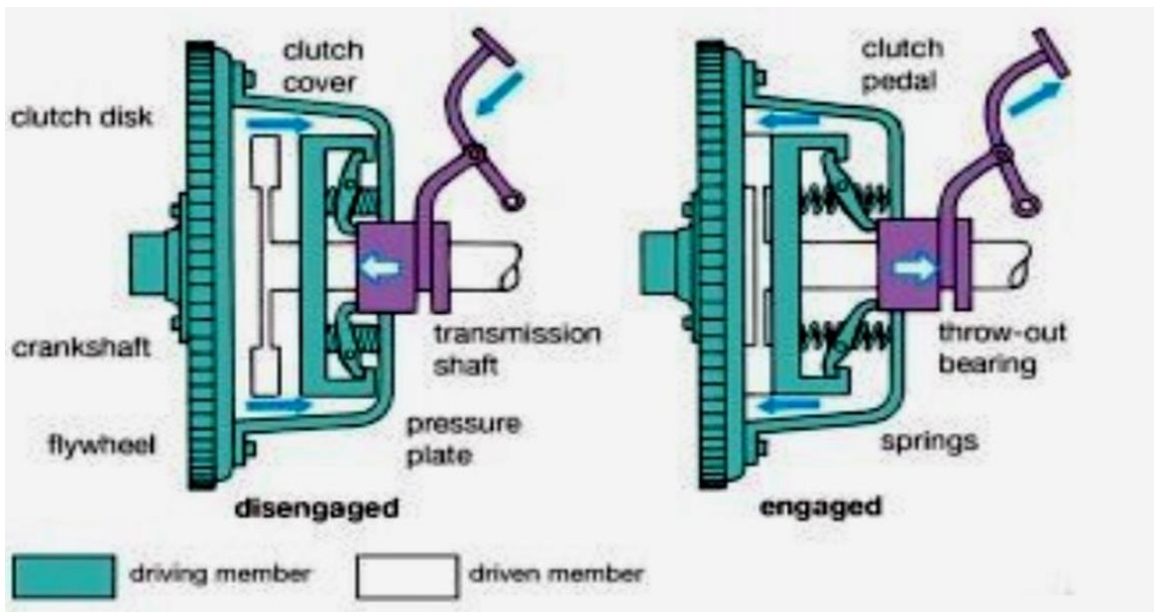
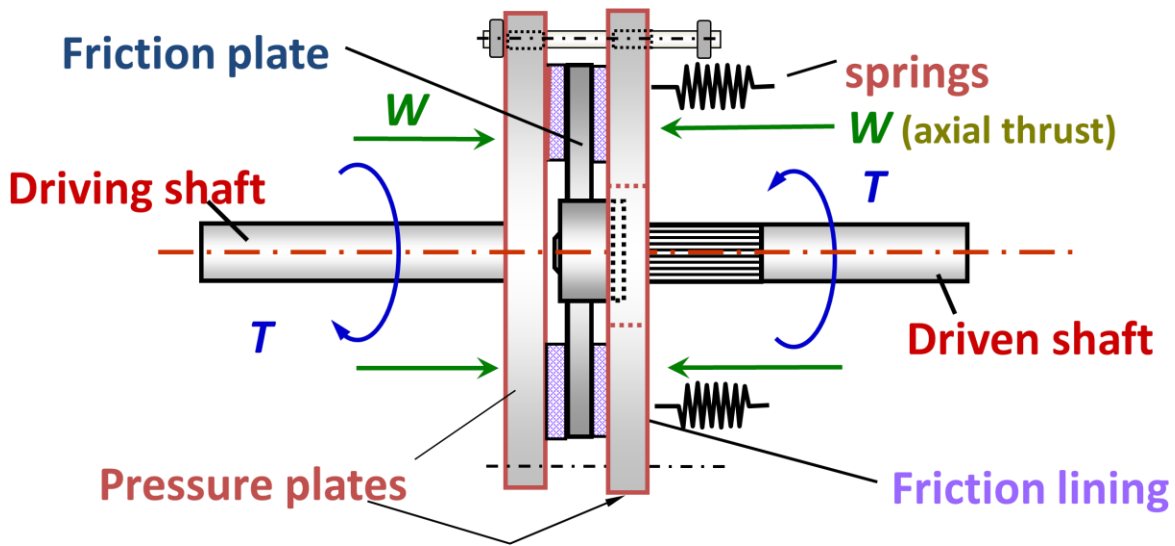
against the flywheel by the pressure plate- because of the force exerted by pressure springs. The pressure plate will keep on pressing the facings of driven plate until friction created becomes equal to the resistance of the vehicle. Any further increase in pressure will cause the clutch plate and the transmission shaft to turn along with flywheel, thus achieving vehicle movement.

### **Single Clutch Plate:**

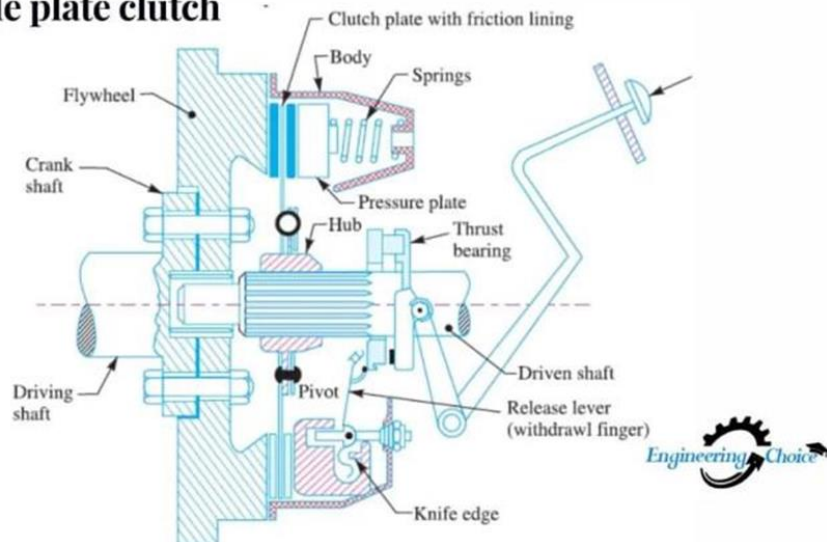
It is the most common type of clutch plate used in motor vehicles. Basically it consists of only one clutch plate, mounted on the splines of the clutch shaft. The flywheel is mounted on engine crankshaft and rotates with it. The pressure plate is bolted to the flywheel through clutch springs, and is free to slide on the clutch shaft when the clutch pedal is operated. When the clutch is engaged the clutch plate is gripped between the flywheel and pressure plate. The friction linings are on both the sides of the clutch plate. Due to the friction between the flywheel, clutch plate and the pressure plate the clutch plate revolves the flywheel. As the clutch plate revolves the clutch shaft also revolves. Clutch shaft is connected to the transmission gear box. Thus the engine power is transmitted to the crankshaft and then to the clutch shaft.

When the clutch pedal is pressed, the pressure plate moves back against the force of the springs, and the clutch plate becomes free between the flywheel and the pressure plate. Thus the flywheel remains rotating as long as the engine is running and the clutch shaft speed reduces slowly and finally it stops rotating. As soon as the clutch pedal is released, the clutch is said to be engaged, otherwise it remains disengaged due to the spring forces.





### Single plate clutch

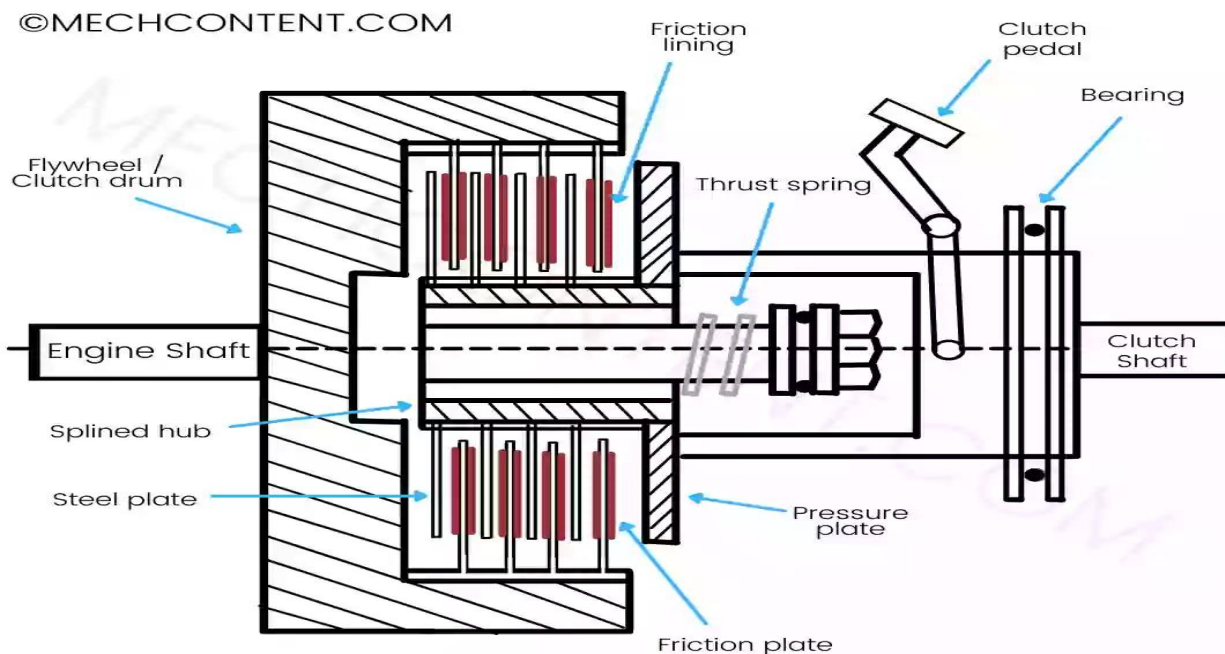


## Multi-plate Clutch:

Multi-plate clutch consists of a number of clutch plates instead of only one clutch plate as in case of single plate clutch. As The number of clutch plates are increased, the friction surfaces also increases. The increased number of friction surfaces obviously increases the capacity of the clutch to transmit torque.

The plates are alternately fitted to engine and gear box shaft. They are firmly pressed by strong coil springs and assembled in a drum. Each of the alternate plate slides on the grooves on the flywheel and the other slides on splines on the pressure plate. Thus, each alternate plate has inner and outer splines.

The multi-plate clutch works in the same way as a single plate clutch by operating the clutch pedal. The multi-plate clutches are used in heavy commercial vehicles, racing cars and motor cycles for transmitting high torque. The multi-plate clutch may be dry or wet. When the clutch is operated in an oil bath, it is called a wet clutch. When the clutch is operated dry it is called dry clutch. The wet clutch is used in conjunction with or part of the automatic transmission.



### Advantages:

- The multi plate clutch has the following advantages:-
- Less effort requires to operate this clutch.
- It is compact in size and hence requires less space.
- It has a high power transmission capacity.

### Disadvantages:

- The multi plate clutch has the following disadvantages:-
- It uses many numbers of plates hence more heat generates in this type of clutch.
- It is heavier in weight.
- It is costlier.



*Fig: Cutaway Model Of Multi-Plate Clutch*



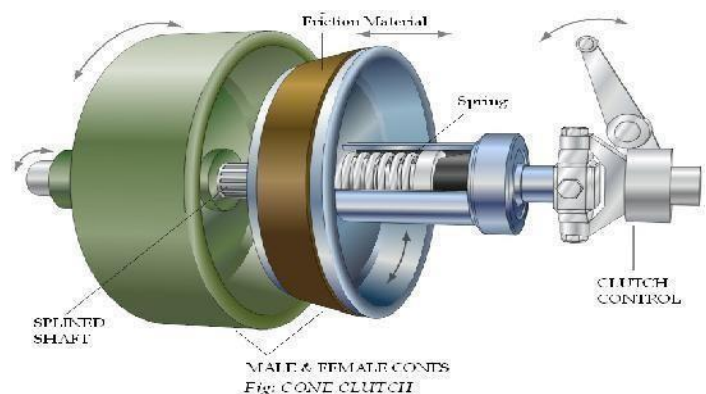
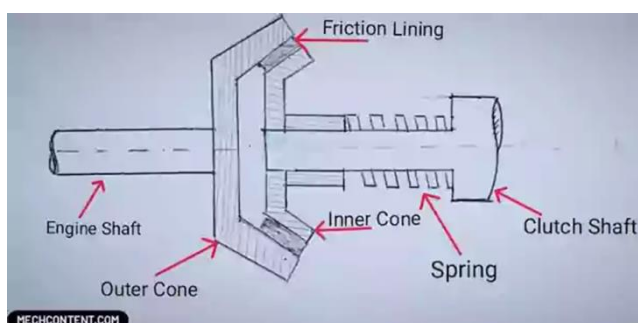
*Fig: Exploded View Of Multi-Plate Clutch*

*Fig: Multi-Plate Clutch*

### Cone Clutch:

Cone clutch consists of friction surfaces in the form of cone. The engine shaft consists of female cone. The male cone is mounted on the splined clutch shaft. It has friction surfaces on the conical portion. The male cone can slide on the clutch shaft. Hence the clutch is engaged the friction surfaces of the male cone are in contact with that of the female cone due to force of the spring. When the clutch pedal is pressed, the male cone slides against the spring force and the clutch is disengaged.

The only advantage of the cone clutch is that the normal force acting on the friction surfaces is greater than the axial force, as compared to the single plate clutch in which the normal force acting on the friction surfaces is equal to the axial force. The disadvantage in cone clutch is that if the angle of the cone is made smaller than  $20^\circ$  the male cone tends to bind in the female cone and it becomes difficult to disengage the clutch. Cone clutches are generally now only used in low peripheral speed



*Fig: CONE CLUTCH*



applications although they were once common in automobiles and other combustion engine transmissions. They are usually now confined to very specialist transmissions in racing, rallying, or in extreme off-road vehicles, although they are common in power boats. Small cone clutches are used in synchronizer mechanisms in manual transmissions.

#### **Cone clutch advantages:**

- It has advantage of higher power transmission capacity as compared to other plate types clutches since more surface area.
- Simple in construction.

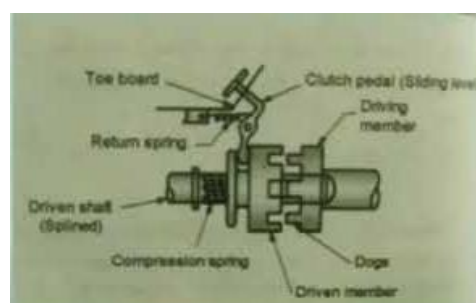
#### **Cone clutch disadvantages:**

- Cone clutch has the disadvantage that if cones have less cone angle then there becomes a difficulty in disengagement.

### **Dog & Spline Clutch:**

This type of clutch is used to lock two shafts together or to lock a gear to shaft. It consists of a sleeve having two sets of internal splines. It slides on a splined shaft with smallest diameter splines. The bigger diameter splines match with the external dog clutch teeth on driving shaft. When the sleeve is made to slide on the splined shaft, its teeth match with the dog clutch teeth of the driving shaft. Thus the sleeve turns the splined shaft with the driving shaft.

The clutch is said to be engaged. To disengage the clutch, the sleeve is moved back on the splined shaft to have no contact with the driving shaft. This type of clutch has no tendency to slip. The driven shaft revolves exactly at the same speed of the driving shaft, as soon as the clutch is engaged. This is also known as positive clutch.



## **Centrifugal Clutch:**

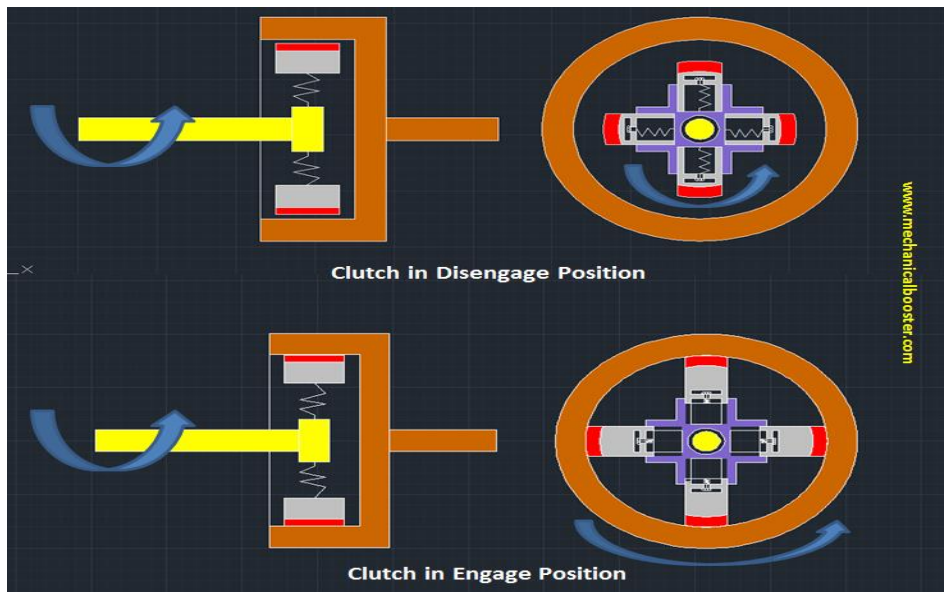
The centrifugal clutch uses centrifugal forces, instead of spring force for keeping it in engaged position. Also, it does not require clutch pedal for operating the clutch. The clutch is operated automatically depending on engine speed. The vehicle can be stopped in gear without stalling the engine. Similarly the gear can be started in any gear by pressing the accelerator pedal.

A centrifugal clutch works through centrifugal force. The input of the clutch is connected to the engine crankshaft while the output drives gear box shaft, chain, or belt. As engine R.P.M. increases, weighted arms in the clutch swing outward and force the clutch to engage. The most common types have friction pads or shoes radially mounted that engage the inside of the rim of housing.

On the center shaft there are an assorted amount of extension springs, which connect to a clutch shoe. When the center shaft spins fast enough, the springs extend causing the clutch shoes to engage the friction face. It can be compared to a drum brake in reverse. The weighted arms force these disks together and engage the clutch.

When the engine reaches a certain RPM, the clutch activates, working almost like a continuously variable transmission. As the load increases the R.P.M. drops thereby disengaging the clutch and letting the rpm rise again and reengaging the clutch. If tuned properly, the clutch will tend to keep the engine at or near the torque peak of the engine.

These results in a fair bit of waste heat, but over a broad range of speeds it is much more useful than a direct drive in many applications. Weaker spring/heavier shoes will cause the clutch to engage at a lower R.P.M. while a stronger spring/lighter shoes will cause the clutch to engage at a higher R.P.M.



### Semi-centrifugal Clutch:-

A semi centrifugal clutch is used to transmit power from high powered engines and racing car engines where clutch disengagements requires appreciable and tiresome drivers effort. The transmission of power in such clutches is partly by clutch springs and rest by centrifugal action of an extra weight provided in system. The clutch springs serve to transmit the torque up to normal speeds, while the centrifugal force assists at speeds higher than normal.

Besides clutch, pressure plate and splines shaft it mainly consists of: Compression spring (3 numbers)

Weighted levers (3 numbers)

At normal speeds when the power transmission is low the spring keeps the clutch engaged, the weighted levers do not have any pressure on the pressure plate. At high speed, when the power transmission is high the weights fly off and levers exert pressure on the plate which keeps the clutch firmly engaged. Thus instead of having more stiff springs for keeping the clutch engaged firmly at high speeds, they are less stiff, so that the driver may not get any strain in operating the clutch.

when the speed decreases, the weights fall and the levers do not exert any pressure on the pressure

plate. Only the spring pressure is exerted on the pressure plate which is sufficient to keep the clutch engaged.

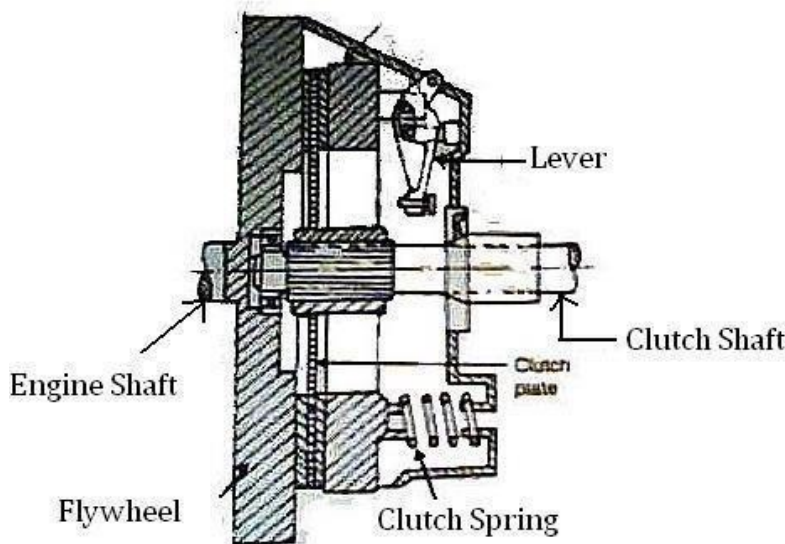


Fig: Semicentrifugal Clutch

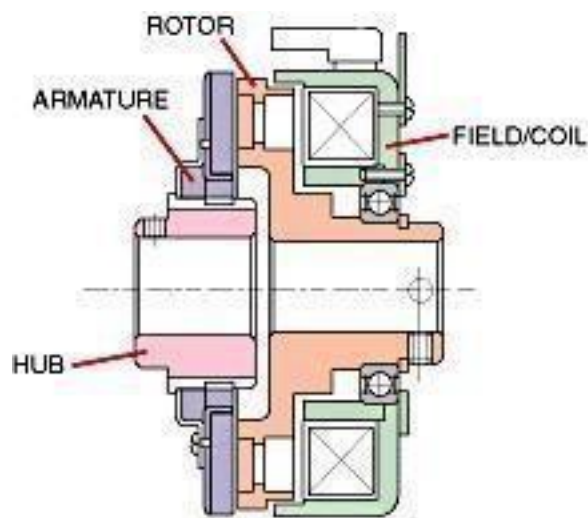
### **Electromagnetic Clutch:**

An electromagnetic clutch is a clutch (a mechanism for transmitting rotation) that is engaged and disengaged by an electromagnetic actuator. In this type of clutch, the flywheel consists of winding. The current is supplied to the winding from battery or dynamo.

When the current passes through the winding it produces an electromagnetic field which attracts the pressure plate, thereby engaging the clutch. When supply is cutoff, the clutch is disengaged. The gear lever consists of a clutch release switch. When then the driver holds the gear lever to change the gear the witch is operated cutting off the current to the winding which causes the clutch disengaged. At low speeds when the dynamo output is low, the clutch is not firmly engaged.

Therefore three springs are also provided on the pressure plate which helps the clutch engaged firmly at low speed also. Cycling is achieved by turning the voltage/current to the electromagnet on and off. Slippage normally occurs only during acceleration. When the clutch is fully engaged, there is no relative slip, assuming the clutch is sized properly, and thus torque transfer is 100% efficient.

The electromagnetic clutch is most suitable for remote operation since no linkages are required to control its engagement. It has fast, smooth operation. However, because energy dissipates as heat in the electromagnetic actuator every time the clutch is engaged, there is a risk of overheating. Consequently the maximum operating temperature of the clutch is limited by the temperature rating of the insulation of the electromagnet. This is a major limitation. Another disadvantage is higher initial cost.



*Fig: Electromagnetic Clutch*

## **Gear Box;**

A gearbox is a mechanical method of transferring energy from one device to another and is used to increase torque while reducing speed. Torque is the power generated through the bending or twisting of a solid material. This term is often used interchangeably with transmission located at the junction point of a power shaft, the gearbox is often used to create a right angle change in direction, as is seen in a rotary mower or a helicopter. Each unit is made with a specific purpose in mind, and the gear ratio used is designed to provide the level of force required. This ratio is fixed and cannot be changed once the box is constructed. The only possible modification after the fact is an adjustment that allows the shaft speed to increase, along with a corresponding reduction in torque. In a situation where multiple speeds are needed, a transmission with multiple gears can be used to increase torque while slowing down the output speed. This design is commonly found in automobile transmissions. The

same principle can be used to create an overdrive gear that increases output speed while decreasing torque.

## Principle of Gearing

Consider a simple 4-gear train. It consists of a driving gear A on input shaft and a driven gear D on the output shaft. In between the two gears there are two intermediate gears B, C. Each of these gears are mounted on separate shaft. We notice that:

Gear A drives Gear B

$$\therefore \frac{N_b}{N_a} = \frac{T_a}{T_b}$$

Gear B drives Gear C

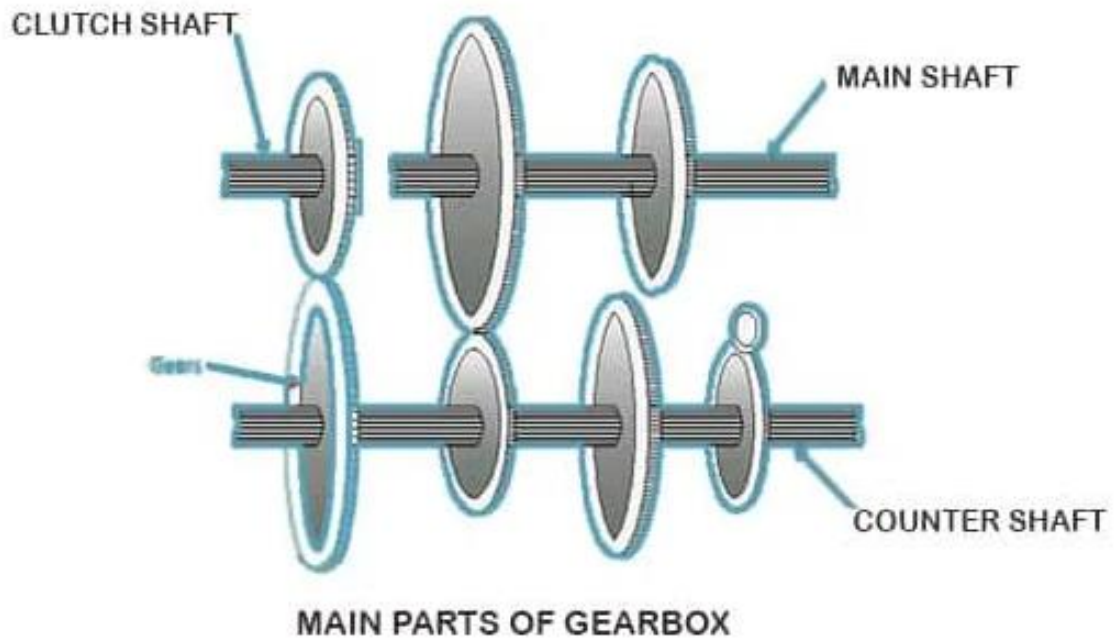
$$\therefore \frac{N_c}{N_b} = \frac{T_b}{T_c}$$

Gear C drives Gear D

$$\therefore \frac{N_d}{N_c} = \frac{T_c}{T_d}$$

Therefore, the over all speed ratios are:

$$\therefore \frac{N_d}{N_a} = \frac{T_c}{T_d} \times \frac{T_b}{T_c} \times \frac{T_a}{T_b} = \frac{T_a}{T_d}$$



### Types of Gear Boxes:

The following types of gear box are used in automobiles:

- Sliding Mesh
- Constant Mesh
- Synchromesh

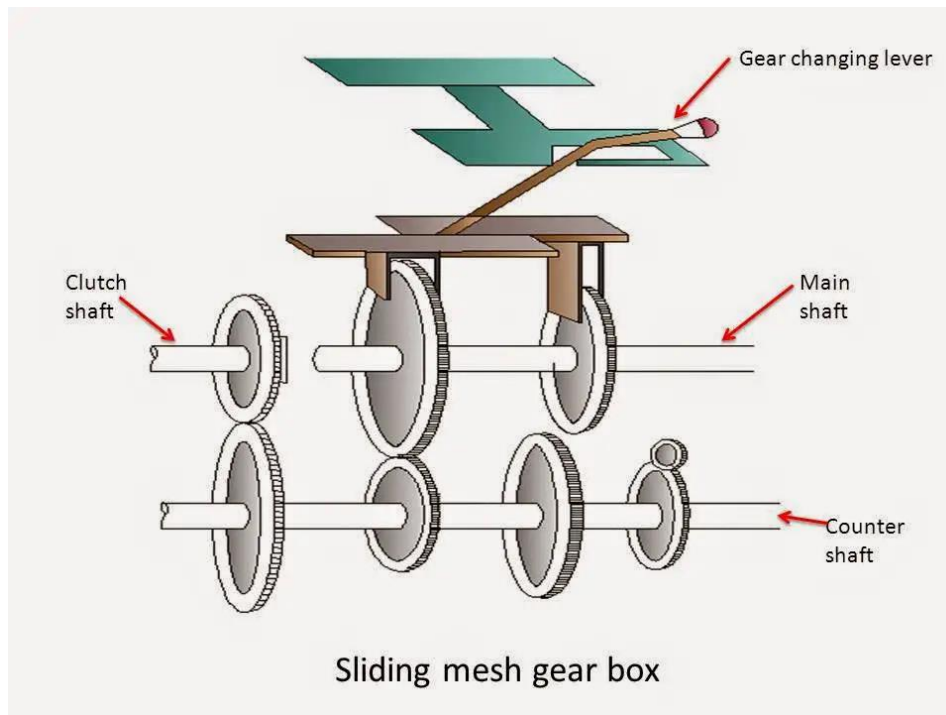
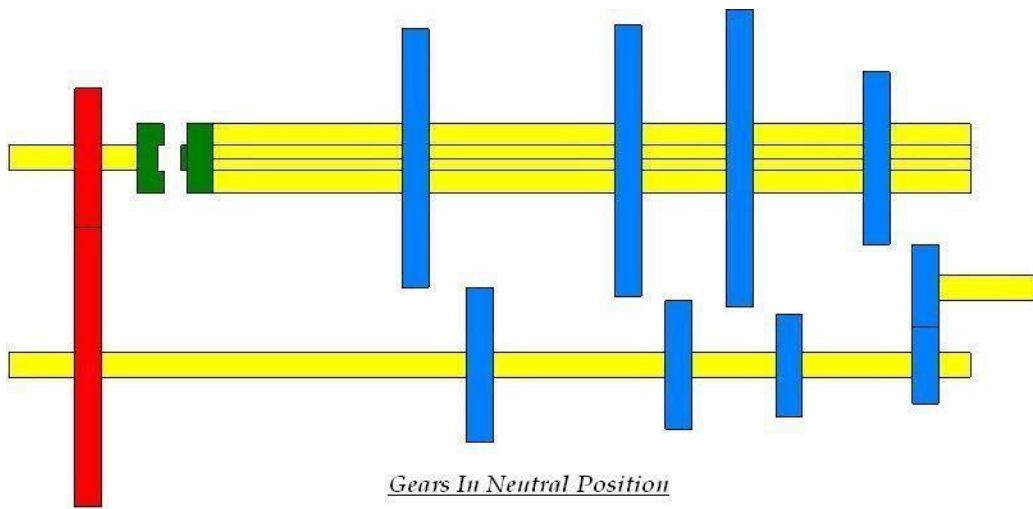
### Sliding Mesh Gear Box

It is the simplest gear box. The following figure shows 4-speed gear box in neutral position. 4 gears are connected to the lay shaft/counter shaft. A reverse idler gear is mounted on another shaft and always remains connected to the reverse gear of countershaft. This “H” shift pattern enables the driver to select four different gear ratios and a reverse gear.

### Gears in Neutral:

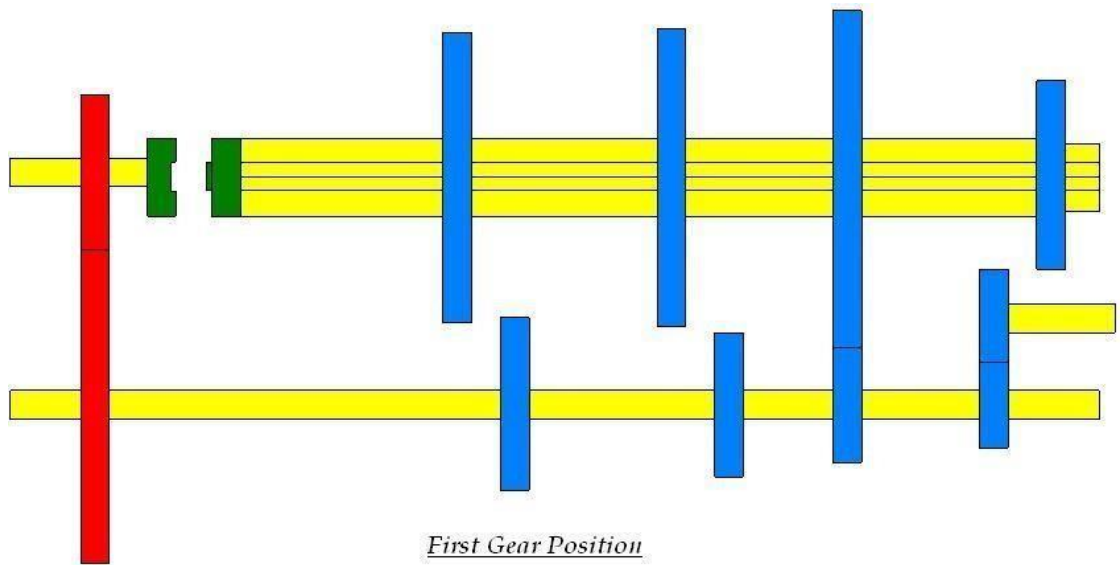
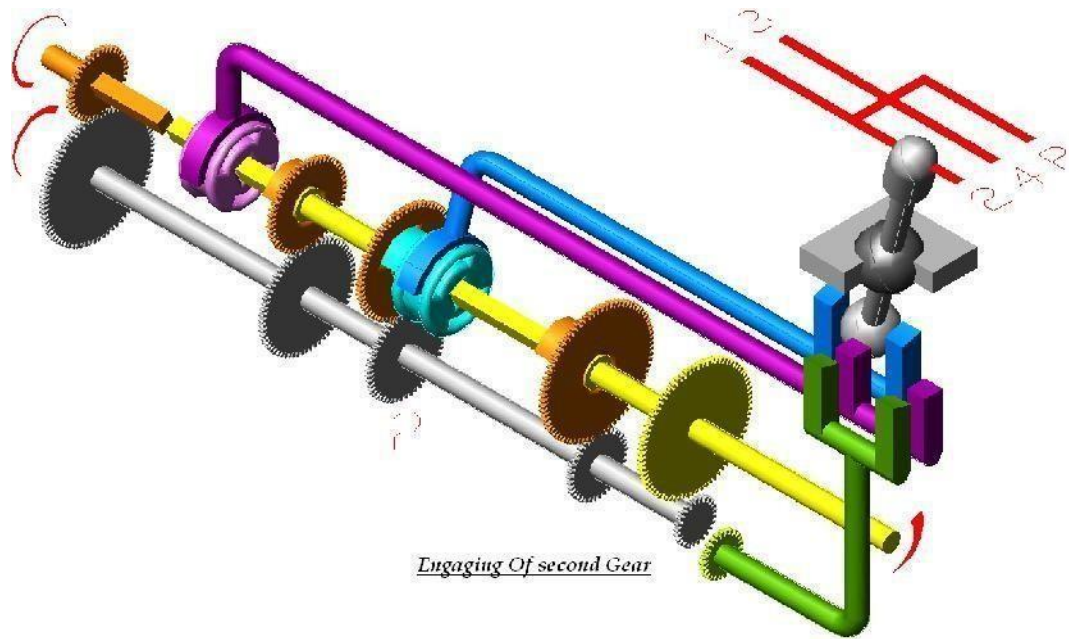
When the engine is running and clutch is engaged the clutch shaft gear drives the countershaft gear. The countershaft rotates opposite in direction of the clutch shaft. In neutral position only the clutch shaft gear is connected to the countershaft gear. Other gears are free and hence the transmission main

shaft is not turning. The vehicle is stationary.



### First or low shaft gear:

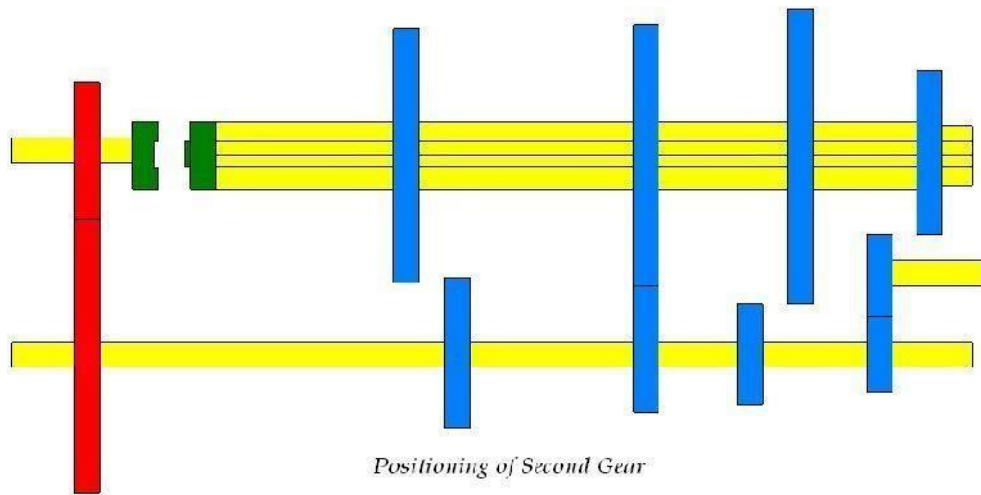
By operating the gear shift lever the larger gear on the main shaft is moved along the shaft to mesh with the first gear of the counter shaft. The main shaft turns in the same direction as that of the clutch shaft. Since the smaller countershaft is engaged with larger shaft gear a gear reduction of approximately 4:1 is obtained i.e. the clutch shaft turns 4 times for each revolution of main shaft.



## Second speed gear:

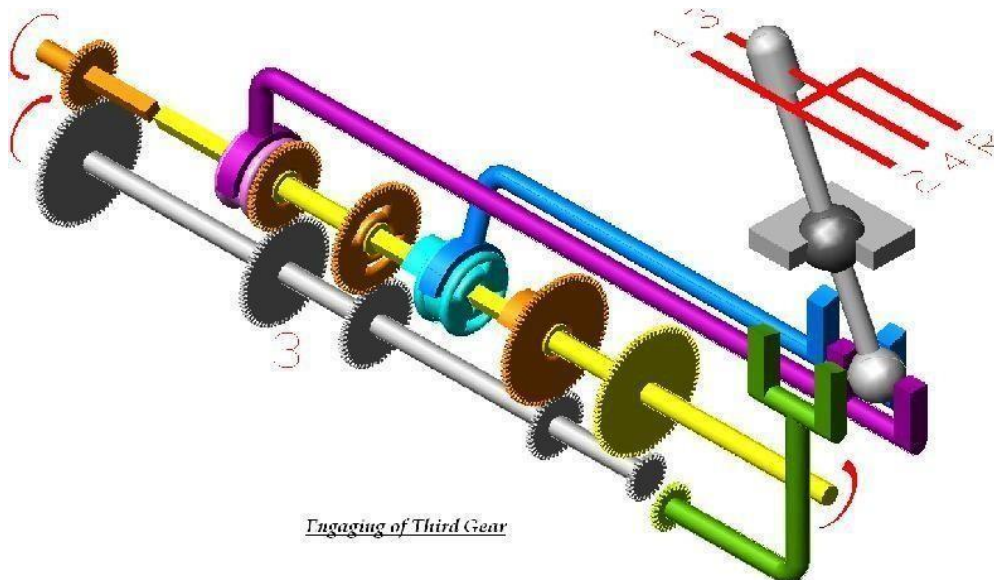
By operating the gear shift lever the third gear on the main shaft is moved along the shaft to mesh with the third gear of the counter shaft. The main shaft turns in same direction as clutch shaft. A gear reduction of approximately 3:1 is obtained.

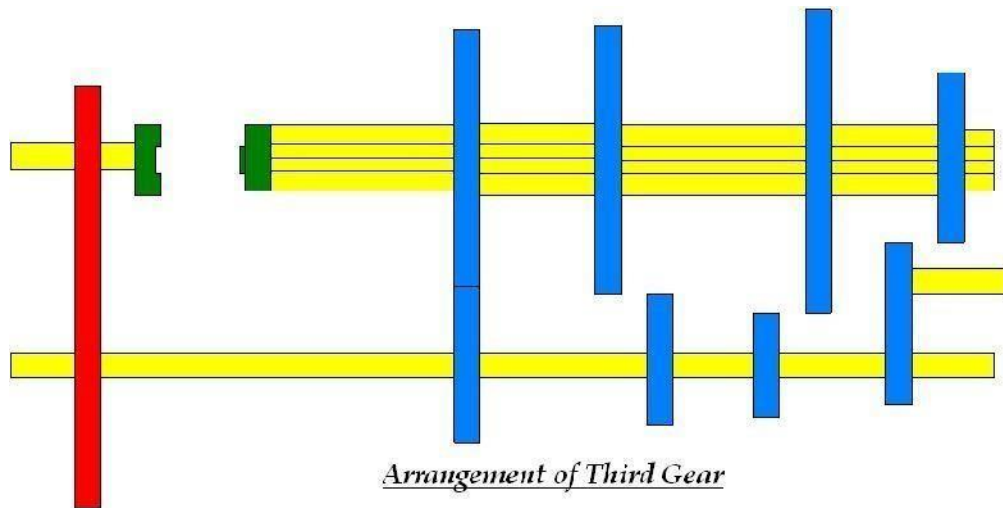




### **Third speed gear:**

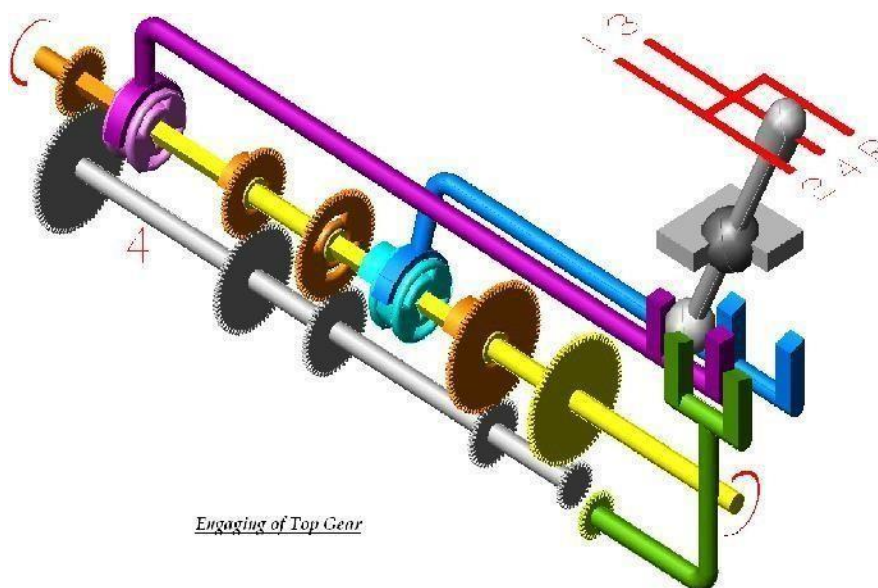
By operating the gear shift lever, the second gear of the main shaft and countershaft are demeshed and then the third gear of the main shaft are forced axially against the clutch shaft gear. External Teeth on the clutch shaft gear mesh with the internal teeth in the third and top gear. The main shaft turns in same direction as clutch shaft. A gear reduction of approximately 2:1 is obtained i.e. the clutch shaft turns 2 times for each revolution of main shaft.

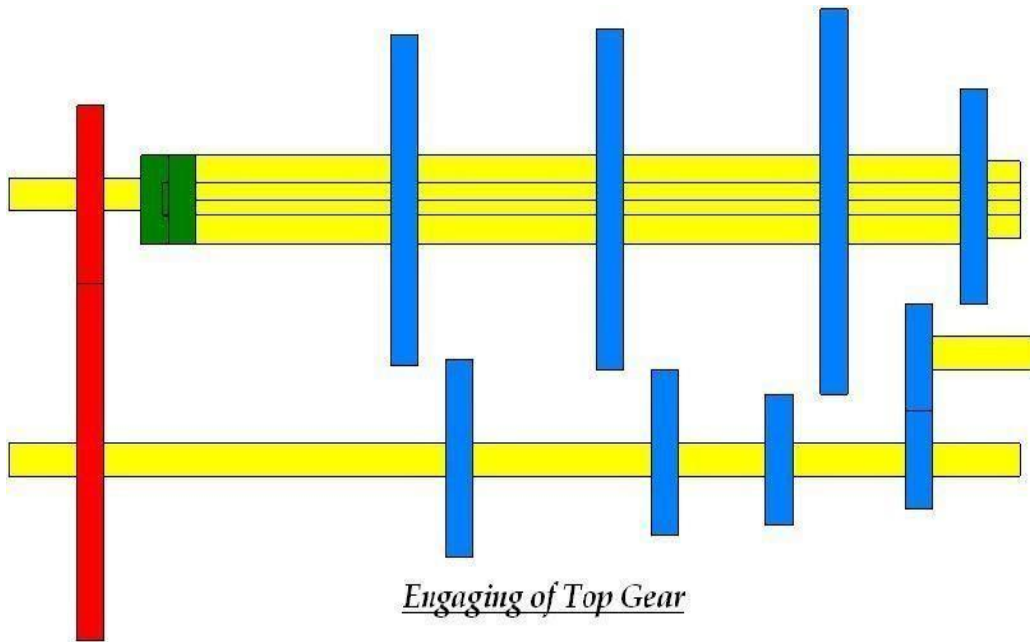




### **Fourth speed gear/ Top or High-Speed Gear:**

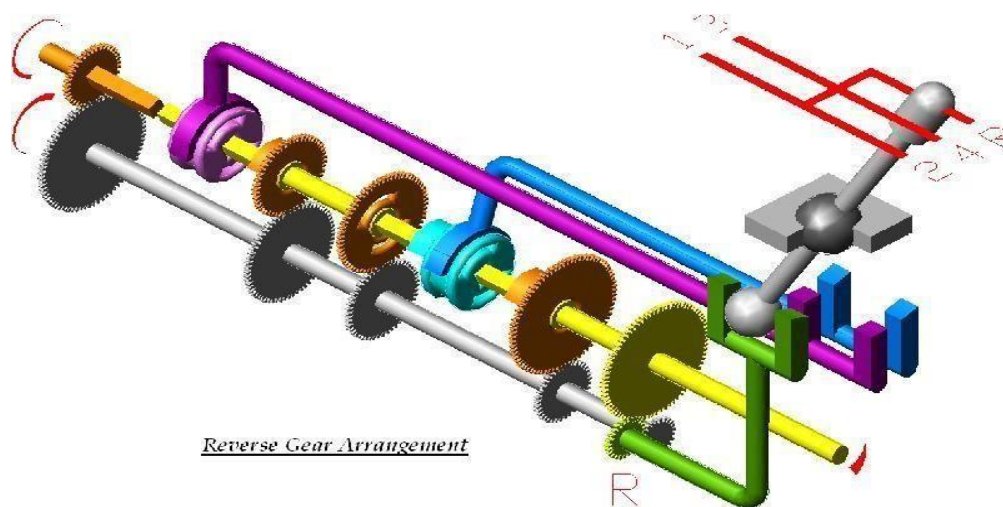
By operating the gear shaft lever the third gears of the main and countershaft is demeshed and the gears present on the main shaft along with the shaft is forced axially against the clutch shaft gear. External teeth present on the main shaft engage with the internal teeth present on the main shaft. The main shaft turns along with the clutch shaft and a gear ratio of approximately 1:1 is obtained.

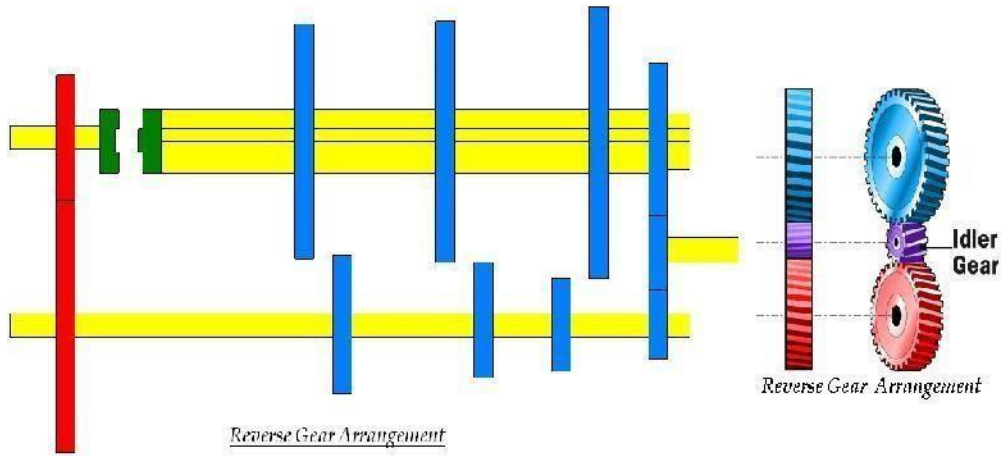




**Reverse gear:**

By operating the gear shift lever, the last gear present on the main shaft is engaged with the reverse idler gear. The reverse idler gear is always in mesh with the countershaft gear. Interposing the idler gear between the counter-shaft reverse gear and main shaft gear, the main shaft turns in the direction opposite to the clutch shaft. This reverses the rotation of the wheels so that the wheel backs.

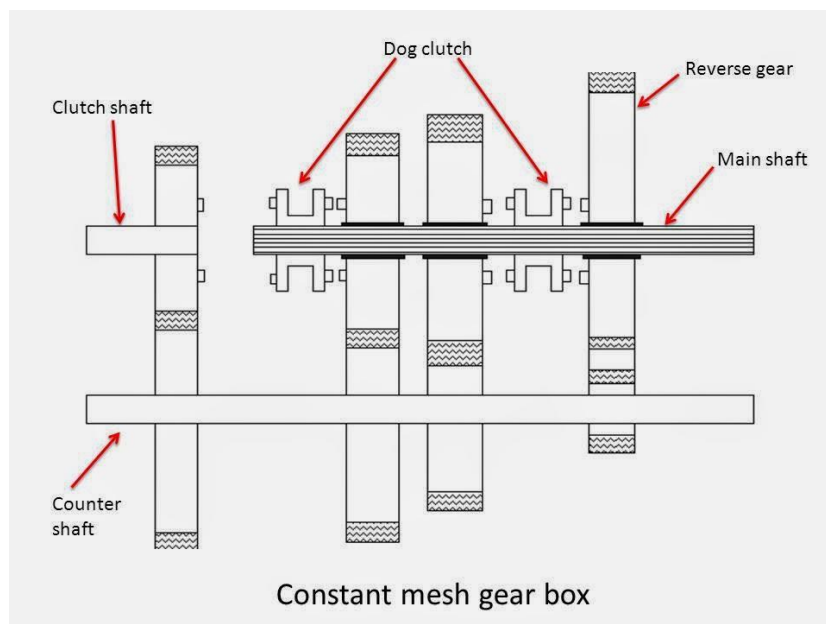




## Constant Mesh Gear Box:

In this type of gear box, all gears of the main shaft are in constant mesh with the corresponding gears of the countershaft (Lay shaft). Two dog clutches are provided on the main shaft- one between the clutch gear and the second gear, and the other between the first gear and reverse gear. The main shaft is splined and all the gears are free on it. Dog clutch can slide on the shaft and rotates with it. All the gears on the countershaft are rigidly fixed with it.

When the left hand dog clutch is made to slide to the left by means of the gear shift lever, it meshes with the clutch gear and the top speed gear is obtained. When the left hand dog clutch meshes with the second gear, the second speed gear is obtained. Similarly by sliding the right hand dog clutch to the left and right, the first speed gear and reverse gear are obtained respectively. In this gear box because



all the gears are in constant mesh they are safe from being damaged and an unpleasant grinding sound does not occur while engaging and disengaging them.

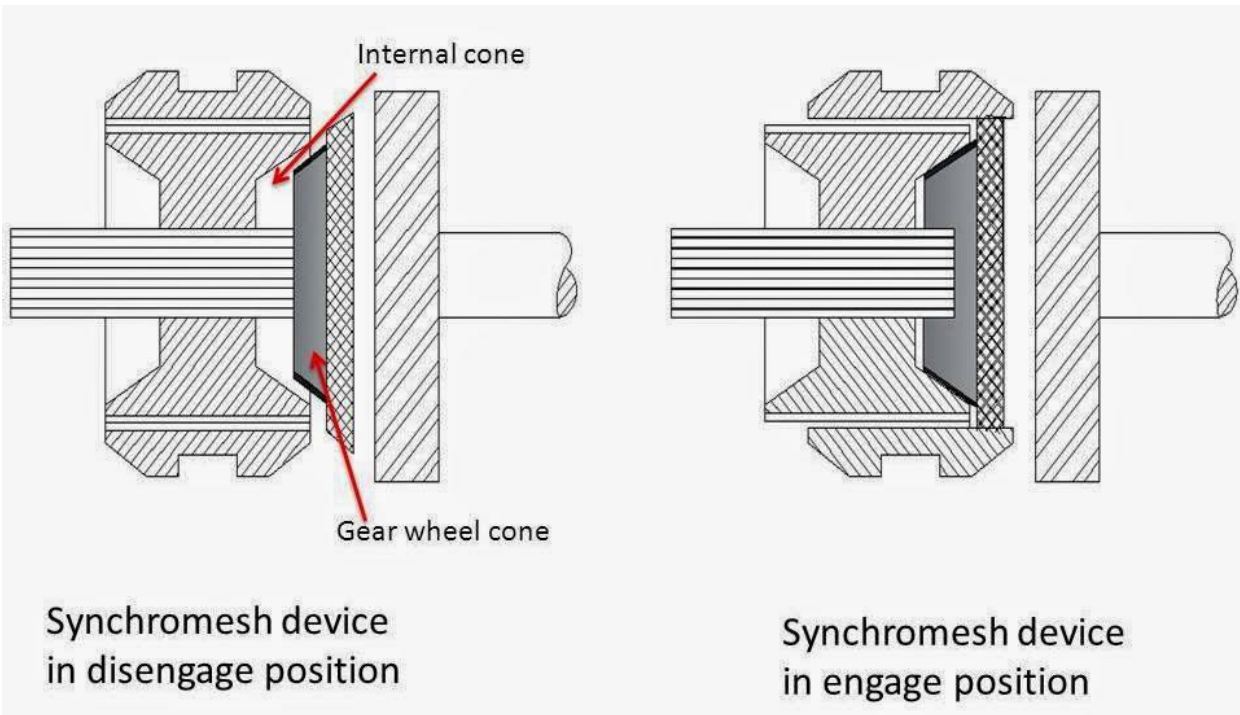
### **Syncromesh Gear Box:**

In sliding Mesh Gear box the two meshing gears need to be revolve at equal peripheral speeds to achieve a jerk less engagement and it is true for constant mesh gear box in which the peripheral speeds of sliding dog and the corresponding gear on the output shaft must be equal. The peripheral speed is given by  $v = \frac{\pi d_1 N_1}{60}$  Where  $d_1$  and  $N_1$  are pitch circle diameter and r.p.m. of gear and  $d_2$  and  $N_2$  diameter and r.p.m. of attached dog respectively. Now  $N_1 \neq N_2$  since  $d_1 \neq d_2$ . Thus there is a difference in gear and dog which necessitates double declutching. The driver has to disengage the clutch twice in quick succession therefore it is referred as double declutching. There are two steps involved in this process:

The clutch is disengaged i.e. first declutching and the gear system is placed in its neutral position. Now the clutch is reengaged and acceleration pedal is pressed to adjust the engine speed according to driver's judgment. The clutch is disengaged (i.e. second declutching) again the appropriate gear is engaged and then the clutch is reengaged

It is that gear box in which sliding synchronizing units are provided in place of sliding dog clutches as in case of constant mesh gear box. With the help of synchronizing unit, the speed of both the driving and driven shafts is synchronized before they are clutched together through train of gears. The arrangement of power flow for the various gears remains the same as in constant mesh gear box. The synchronizer is made of frictional materials. When the collar tries to mesh with the gear, the synchronizer will touch the gear first and use friction force to drive the gear to spin at the same speed as the collar. This will ensure that the collar is meshed into the gear very smoothly without grinding. Syncromesh gear devices work on the principle that two gears to be engaged are first brought into frictional contact which equalizes their speed after which they are engaged readily and smoothly.





A transmission in which various speeds are obtained automatically is known as automatic transmission. In this type of gear box driver merely selects the general car condition such as forward or reverse. The selection, timing and engagement of gear for the required gear speed are accomplished automatically when the accelerator is pressed or depressed. Automatic transmission needs no gear change lever and clutch pedal since clutch and transmission is a combined unit and works automatically.

- Automatic transmission is generally subdivided into two types:
  - (A.) Epicyclic gear box:
  - (B.) Hydraulic torque converter:

## Epicyclic gear box

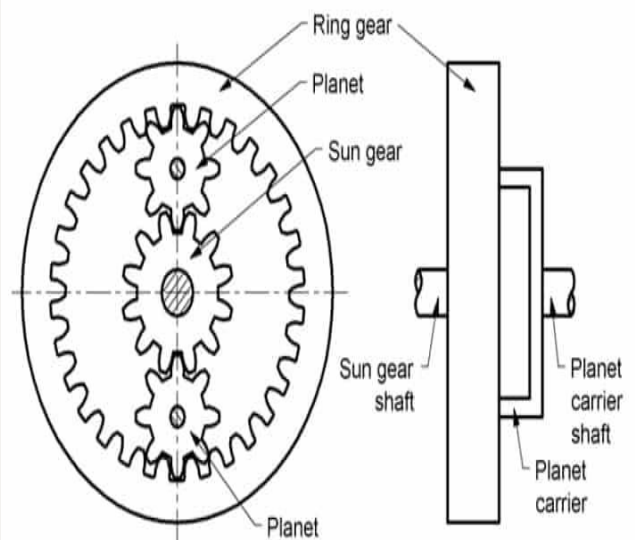
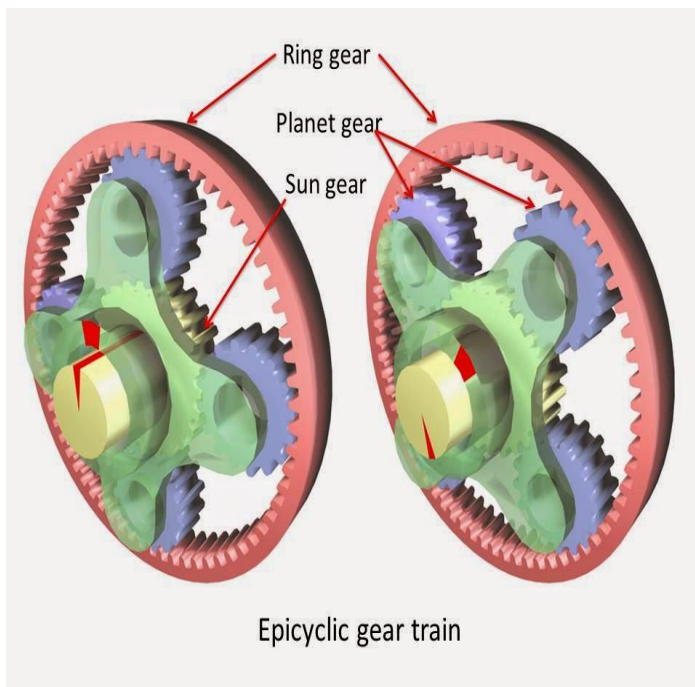


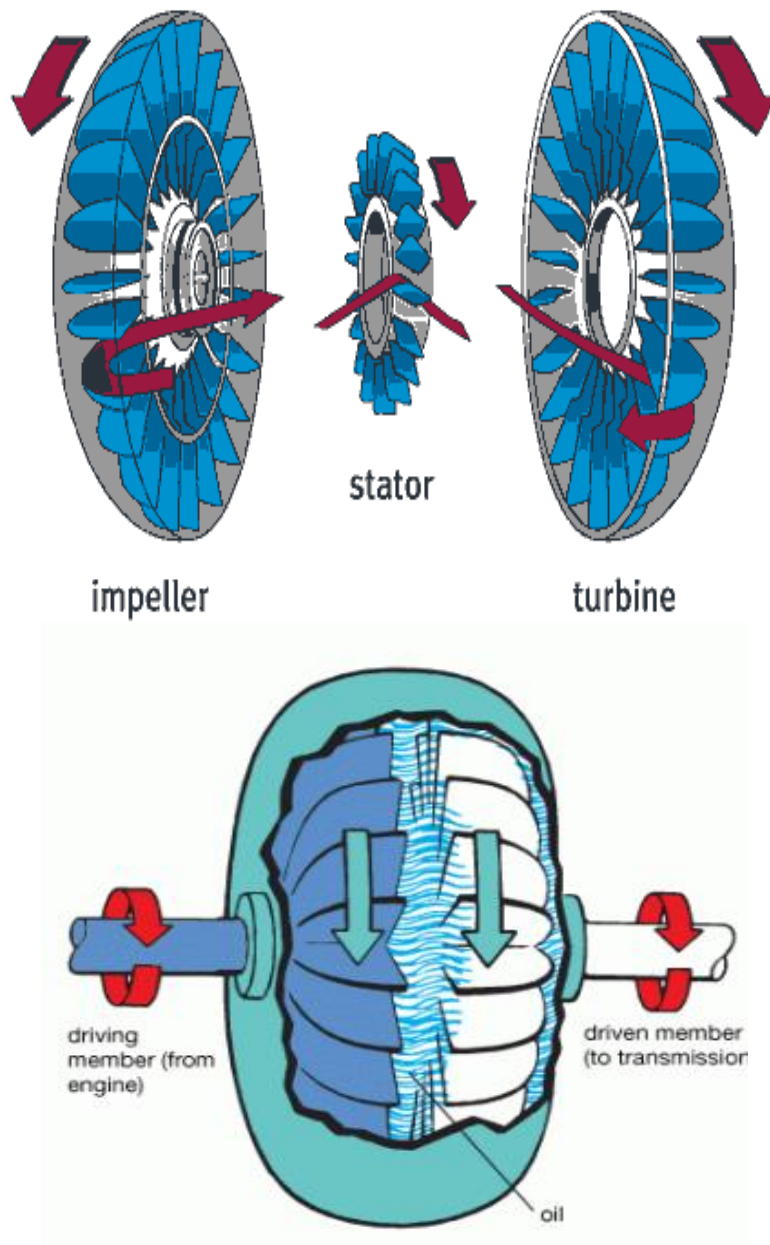
Figure: Simple epicyclic gear box



This type of gear box uses no sliding dogs or gears to engage but different gear speeds are obtained by merely tightening brake bands on gear drum. It consists of a ring gear annular wheel, sun gear and planet gears with carrier. In order to obtain different speeds any one of these units can be held from rotation by means of brake band. The ring gear contains teeth on its inner circumference and is surrounded by a brake band. The brake band is operated by a gear stick or lever to grip the ring gear and hold its movement. The sun gear is attached to the clutch shaft thus moves along with the movement of engine crankshaft. The planet gears are in constant mesh with both the sun gear and ring gear and are free to rotate on their axes carried by the carrier frame which in turn is connected to the driver shaft.

When the ring gear is locked by the brake band, the rotating sun gear causes the planet gears to rotate. Since the ring gear cannot move. The planet gears are forced to climb over it. During this position, the ring gear acts as track for the planet gears to move over. The driven shaft which is connected to the planet gear carrier is thus rotate. When the ring gear is released, it is free to move in consequence to the rotation of planet gears which rotate around their axis. During this position, there is no movement of planet carries and hence the driven shaft remains stationary. A planetary gear box contains a number of such units to obtain various speed reductions

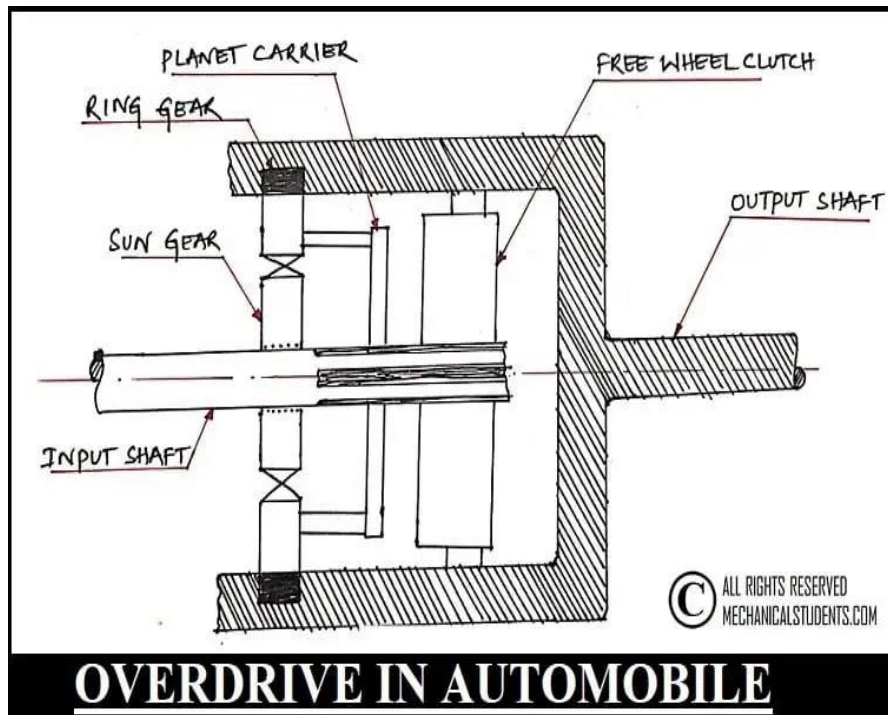
### Hydraulic torque converter:

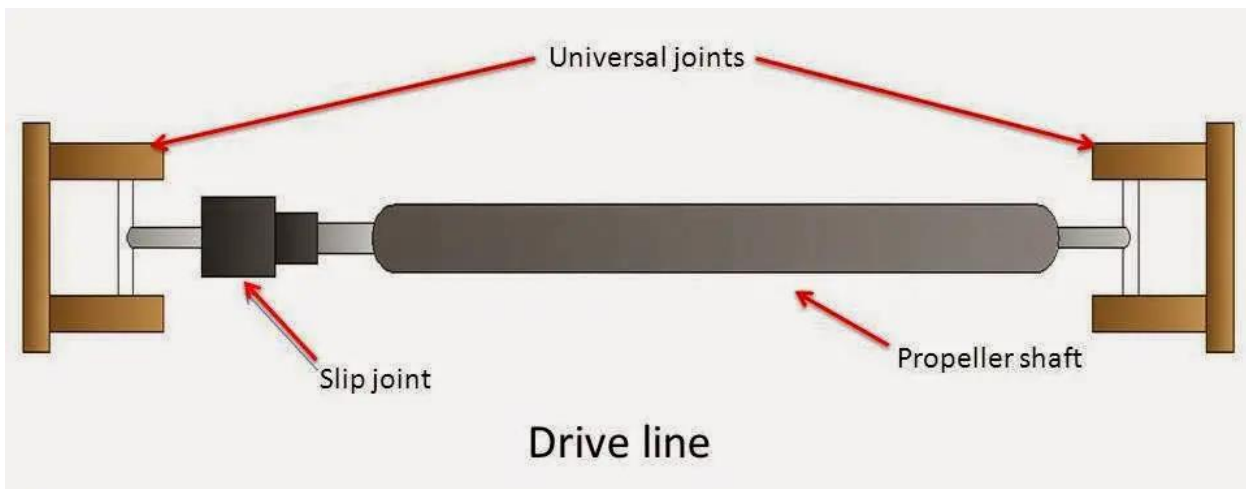


- Hydraulic torque converter is same as the electric transformer. The main purpose of the torque converter is to engage the driving member to driven member and increase the torque of driven member. In the torque converter, an impeller is bolted on the driving member, a turbine is bolted on the driven member and stationary guide vanes are placed between these two members. This all parts are enclosed into single housing filled with hydraulic liquid. The impeller rotates with the driven member and it through the liquid outward by centrifugal action. This liquid flowing from the impeller to turbine runner exerts a torque on the stationary guide vanes which change the direction of liquid, thereby making possible the transformation of torque and speed. The difference of torque between impeller and turbine depends upon these stationary guide vanes. This serves as the function of both gear box and clutch.

**Over Drive Mechanism**

- The overdrive is to be placed in between the Gearbox and the Propeller shaft.
- The function of overdrive is to increase more amount of power than the power delivered from the gearbox.
- On the input shaft, the Sun gear is connected through Spline.
- The freewheel has an internal spline and the Input shaft has an external Spline and these two will mesh together.
- Whenever there is a spline joint, the Freewheel does not undergo any rotary relative motion but it has only horizontal relative motion.
- In the sense, the Freewheel can move only in the horizontal direction but cannot rotate at the center of the input shaft.
- Whereas the sun gear is freely mounted on the input shaft. It means that, whenever the shaft is rotating, the Sun Gear may or may not rotate but the Freewheel has to move w.r.t. the input shaft only.
- The Sun Gear meshes with the planet gears and this planet gears are in contact with the Planet Carrier.
- The Planet Gear is also in contact with the ring gear and from the ring gear, the power is sent to the output shaft.





### U- Joint:

A universal joint, U-joint, Cardan joint, Hardy-Spicer joint, or Hooke's joint is a linkage that transmits rotation between two non parallel shafts whose axes are coplanar but not coinciding., and is commonly used in shafts that transmit rotary motion. It is used in automobiles where it is used to transmit power from the gear box of the engine to the rear axle. The driving shaft rotates at a uniform angular speed, where as the driven shaft rotates at a continuously varying angular speed.

A complete revolution of either shaft will cause the other to rotate through a complete revolution at the same time. Each shaft has fork at its end. The four ends of the two fork are connected by a centre piece, the arms of which rest in bearings, provided in fork ends. The centre piece can be of any shape of a cross, square or sphere having four pins or arms. The four arms are at right angle to each other.

When the two shafts are at an angle other than  $180^\circ$  (straight), the driven shaft does not rotate with constant angular speed in relation to the drive shaft; the more the angle goes toward  $90^\circ$  the jerkier the movement gets (clearly, when the angle  $\beta = 90^\circ$  the shafts would even lock). However, the overall average speed of the driven shaft remains the same as that of driving shaft, and so speed ratio of the driven to the driving shaft on average is 1:1 over multiple rotations.

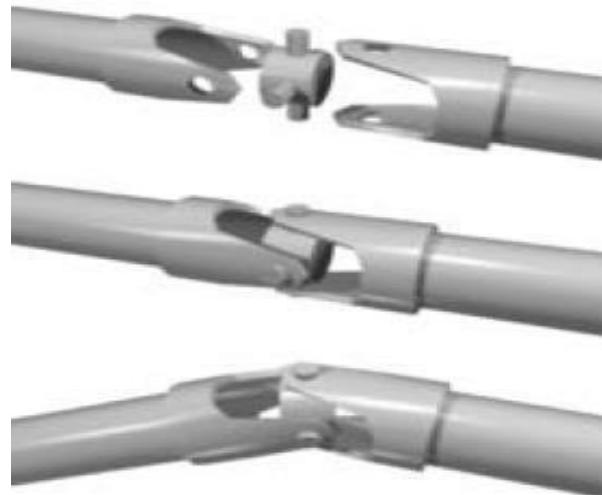
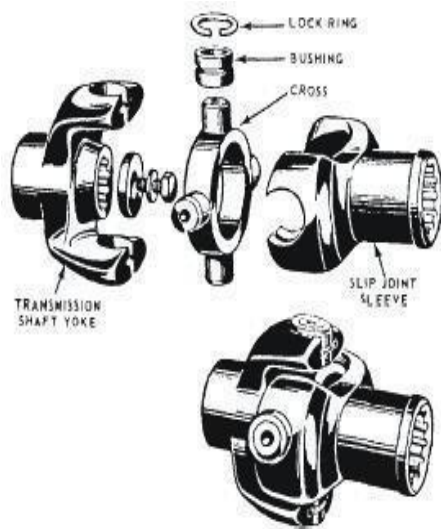
The angular speed  $\omega_2$  of the driven shaft, as a function of the angular speed of the driving shaft



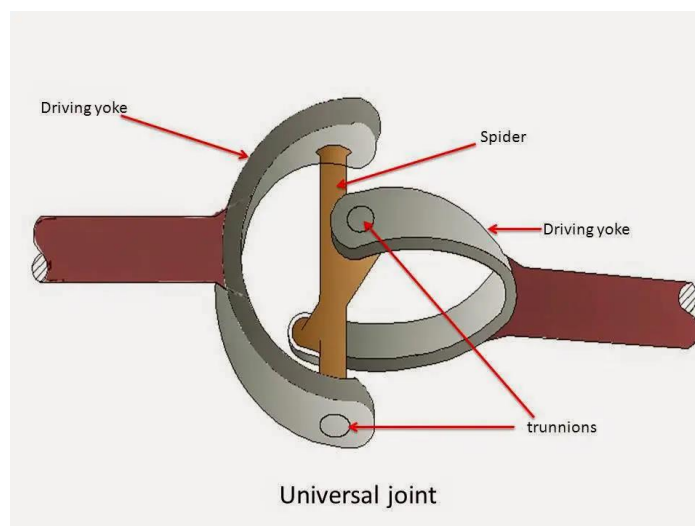
$\omega_1$  and the angle of the driving shaft  $\phi_1$ , is found using:

$$\omega_2 = \omega_1 \cos \alpha / (1 - \sin^2 \alpha \cdot \cos 2\theta)$$

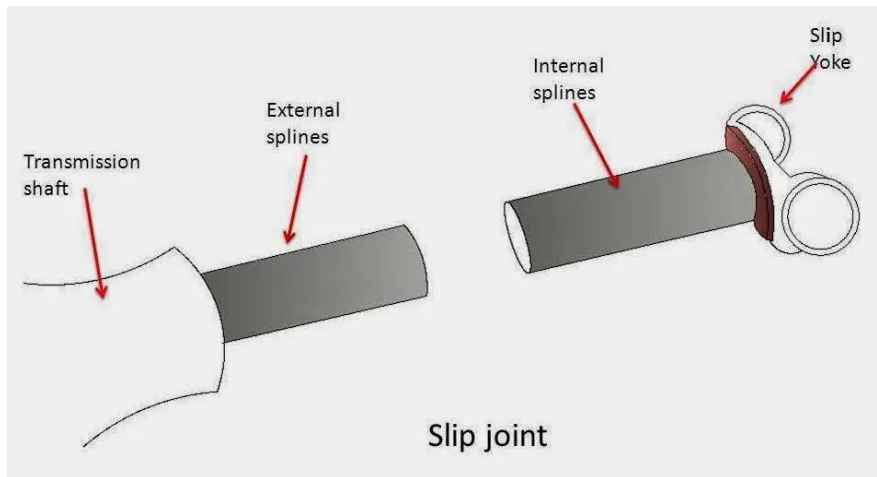
For a given and set angle between the two shafts it can be seen that there is a cyclical variation in the input to output velocity ratio. Maximum values occur when  $\sin \theta = 1$ , i.e. when  $\theta = 90^\circ$  and  $270^\circ$ . The denominator is greatest when  $\theta = 0^\circ$  or  $180^\circ$  and this condition gives the minimum ratio of the velocities.



**Fig: Components and assembly of U-Joint**

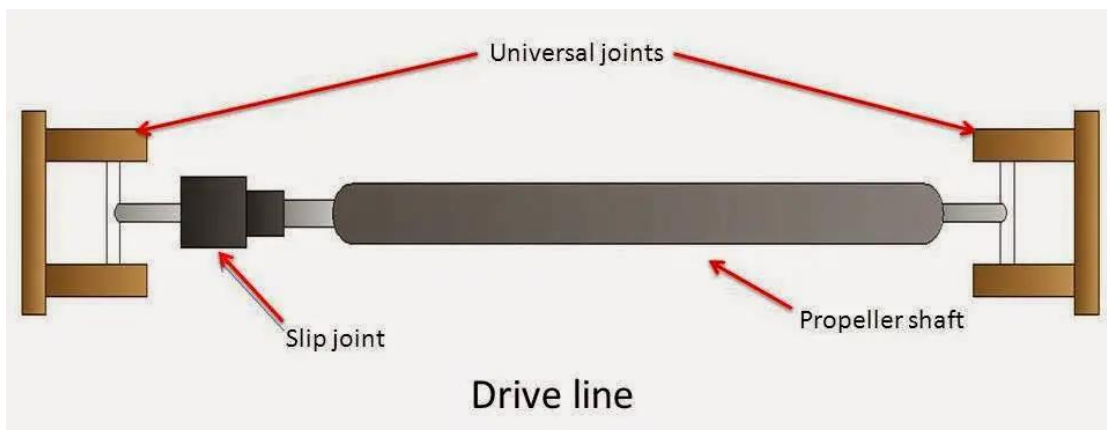


## Slip Joint in the Propeller Shaft;



- Slip joint is attached to the driven yoke in order to increase or decrease the length of propeller shaft. It has outside splines on the shaft and matching internal splines in a mating hollow shaft or yoke. When assembled the splines cause the shafts to rotate together while they can move back and forth. This changes the length of propeller shaft.

## Propeller Shaft



- The propeller shaft is a driving shaft which connects the transmission main shaft to the differential of the rear axle. It transmits the power from gear box to rear axle with the help of universal joints. The propeller shaft is also known as drive shaft. It performs the following function:
- To receive the power from the gear box output shaft and without any change in speed transmit it to the input pinion of the differential for onward transmission to the rear axle and rear wheels. To cope with the difference in line with the level of the gear box output shaft and the differential input pinion shaft. The propeller shaft has to operate at varied lengths and varied angles. The engine of the automobile is somewhat rigidly attached to the frame by springs. As the vehicle moves on the road there are jerks and bumps due to which the springs expand and contract. This changes the angle of drive between the propeller shaft and the transmission shaft. The distance between the gear box and differential also changes due to the movement of the springs. So the propeller shaft has to meet both the angular change coming between the gear box and differential and change in length of the distance between the gear box and differential. The propeller shaft is also not on the same line as the gear box output shaft but it runs to the rear axle at an angle because the level of the rear axle is lower than the gear box. So to adjust angular motion universal joints are provided and to adjust for the change in length of the propeller shaft, a slip joint is provided. The propeller shaft has to withstand the torsional stresses of the transmitting torque, and yet it must be light and well balanced so that vibrations will not occur at high speed. So it is usually made of a strong steel tube.



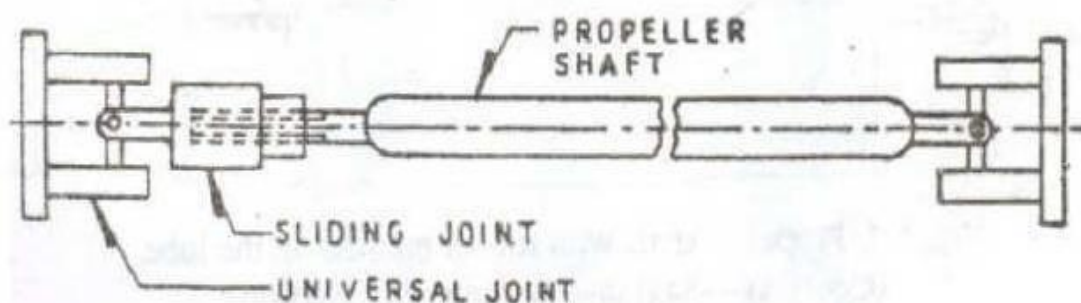
## The Drive Shaft

The drive shaft, or propeller shaft, connects the transmission output shaft to the differential pinion shaft. Since all roads are not perfectly smooth, and the transmission is fixed, the drive shaft has to be flexible to absorb the shock of bumps in the road. Universal, or "U-joints" allow the drive shaft to flex (and stop it from breaking) when the drive angle changes.

Drive shafts are usually hollow in order to weigh less, but of a large diameter so that they are strong. High quality steel, and sometimes aluminum are used in the manufacture of the drive shaft. The shaft must be quite straight and balanced to avoid vibrating. Since it usually turns at engine speeds, a lot of damage can be caused if the shaft is unbalanced, or bent. Damage can also be caused if the U-joints are worn out.

There are two types of drive shafts, the Hotchkiss drive and the Torque Tube Drive. The Hotchkiss drive is made up of a drive shaft connected to the transmission output shaft and the differential pinion gear shaft. U-joints are used in the front and rear. The Hotchkiss drive transfers the torque of the output shaft to the differential. No wheel drive thrust is sent to the drive shaft. Sometimes this drive comes in two pieces to reduce vibration and make it easier to install (in this case, three U-joints are needed). The two-piece types need ball bearings in a dustproof housing as center support for the shafts. Rubber is added into this arrangement for noise and vibration reduction.

The torque tube drive shaft is used if the drive shaft has to carry the wheel drive thrust. It is a hollow steel tube that extends from the transmission to the rear axle housing. One end is fastened to the axle housing by bolts. The transmission end is fastened with a torque ball. The drive shaft fits into the torque tube. A U-joint is located in the torque ball, and the axle housing end is splined to the pinion gear shaft. Drive thrust is sent through the torque tube to the torque ball, to transmission, to engine and finally, to the frame through the engine mounts. That is, the car is pushed forward by the torque tube pressing on the engine.



## **Automatic Transmission:**

An automatic transmission (commonly "AT" or "Auto") is an automobile gearbox that can change gear ratios automatically as the vehicle moves, freeing the driver from having to shift gears manually.

## **Automatic Transmission Modes:**

In order to select the mode, the driver would have to move a gear shift lever located on the steering column or on the floor next to him/her. In order to select gears/modes the driver must push a button in (called the shift lock button) or pull the handle (only on column mounted shifters) out. In some vehicles position selector buttons for each mode on the cockpit instead, freeing up space on the central console. Vehicles conforming to U.S. Government standards must have the modes ordered P- R-N-D-L (left to right, top to bottom, or clockwise). Prior to this, quadrant-selected automatic transmissions often utilized a P-N-D-L-R layout, or similar. Such a pattern led to a number of deaths and injuries owing to un-intentional gear miss-selection, as well the danger of having a selector (when worn) jump into Reverse from Low gear during engine braking maneuvers.

Automatic Transmissions have various modes depending on the model and make of the transmission.

Some of the common modes are:

### **Park Mode (P):-**

This selection mechanically locks the transmission, restricting the car from moving in any direction. A parking pawl prevents the transmission—and therefore the vehicle—from moving, although the vehicle's non-drive wheels may still spin freely. For this reason, it is recommended to use the hand brake (or parking brake) because this actually locks the (in most cases, rear) wheels and prevents them from moving. This also increases the life of the transmission and the park pin mechanism, because parking on an incline with the transmission in park without the parking brake engaged will cause undue stress on the parking pin. An efficiently-adjusted hand brake should also prevent the car from



moving if a worn selector accidentally drops into reverse gear during early morning fast-idle engine warm ups.

### **Reverse (R):-**

This puts the car into the reverse gear, giving the ability for the car to drive backwards. In order for the driver to select reverse they must come to a complete stop, push the shift lock button in (or pull the shift lever forward in the case of a column shifter) and select reverse. Not coming to a complete stop can cause severe damage to the transmission. Many modern automatic gearboxes have a safety mechanism in place, which does to some extent prevent (but doesn't completely avoid) inadvertently putting the car in reverse when the vehicle is moving.

This mechanism usually consists of a solenoid-controlled physical barrier on either side of the Reverse position, which is electronically engaged by a switch on the brake pedal. Therefore, the brake pedal needs to be depressed in order to allow the selection of reverse. Some electronic transmissions prevent or delay engagement of reverse gear altogether while the car is moving.

### **Neutral/No gear (N):-**

This disconnects the transmission from the wheels so the car can move freely under its own weight.

This is the only other selection in which the car can be started.

### **Drive (D):-**

This allows the car to move forward and accelerate through its range of gears. The number of gears a transmission has depends on the model, but they can commonly range from 3, 4 (the most common), 5, 6 (found in VW/Audi Direct Shift Gearbox), 7 (found in Mercedes 7G gearboxes, BMW M5 and VW/Audi Direct Shift Gearbox) and 8 in the newer models of Lexus cars. Some cars when put into D will automatically lock the doors or turn on the Daytime Running Lamps.

### **Overdrive ([D], Od, Or A Boxed D):-**

This mode is used in some transmissions to allow early Computer Controlled Transmissions to engage



the Automatic Overdrive. In these transmissions, Drive (D) locks the Automatic Overdrive off, but is identical otherwise. OD (Overdrive) in these cars is engaged under steady speeds or low acceleration at approximately 35-45 mph (approx. 72 km/h). Under hard acceleration or below 35-45 mph, the transmission will automatically downshift. Vehicles with this option should be driven in this mode unless circumstances require a lower gear.

### **Second (2 or S):-**

This mode limits the transmission to the first two gears, or more commonly locks the transmission in second gear. This can be used to drive in adverse conditions such as snow and ice, as well as climbing or going down hills in the winter time. Some vehicles will automatically up-shift out of second gear in this mode if a certain rpm range is reached, to prevent engine damage.

### **First (1 or L):-**

This mode locks the transmission in first gear only. It will not accelerate through any gear range. This, like second, can be used during the winter season, or for towing.

As well as the above modes there are also other modes, dependent on the manufacturer and model. Some examples include:

D5:- In Hondas and Acuras equipped with 5-speed automatic transmissions, this mode is used commonly for highway use (as stated in the manual), and uses all five forward gears.

D4:- This mode is also found in Honda and Acura 4 or 5-speed automatics and only uses the first 4 gears. According to the manual, it is used for "stop and go traffic", such as city driving.

D3:- This mode is found in Honda and Acura 4-speed automatics and only uses the first 3 gears. According to the manual, it is used for stop & go traffic, such as city driving. This mode is also found in Honda and Acura 5-speed automatics.

This is the manual selection of gears for automatics, such as Porsche's Tiptronic. This feature can also be found in Chrysler and General Motors products such as the Dodge Magnum and Pontiac G6. The driver can shift up and down at will, by toggling the shift lever (console mounted) like a semi-



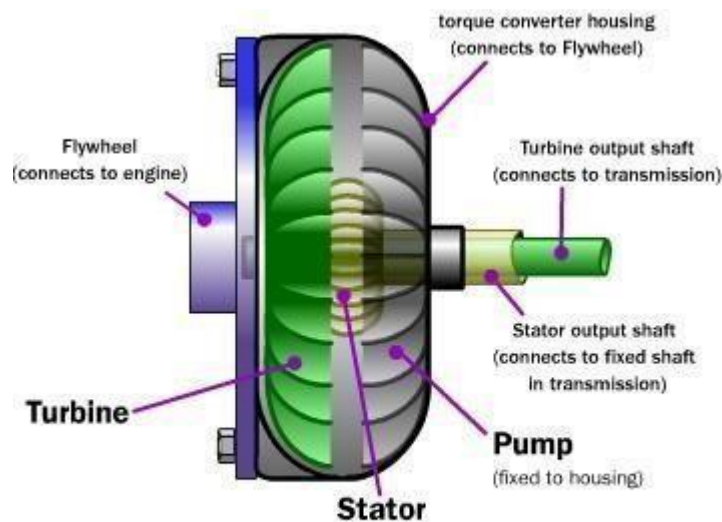
automatic transmission. This mode may be engaged either through a selector/position or by actually changing gear (e.g. tipping the gear-down paddles mounted near the driver's fingers on the steering wheel).

The predominant form of automatic transmission is hydraulically operated, using a fluid coupling/torque converter and a set of planetary gear-sets to provide a range of torque multiplication.

### **Parts and Operation:-**

A hydraulic automatic transmission consists of the following parts:

- Torque Converter/Fluid Coupling
- Planetary Gear Set
- Clutch packs & Bands
- Valve Body
- Hydraulic or Lubricating Oil



*Fig: Cut section Model of Torque converter*

**Torque Converter/Fluid Coupling:** -Unlike a manual transmission system, automatic transmission does not use a clutch to disconnect power from the engine temporarily when shifting gears. Instead, a device called a torque converter was invented to prevent power from being temporarily disconnected from the engine and also to prevent the vehicle from stalling when the transmission is in gear.



A fluid coupling/torque converter consists of a sealed chamber containing two toroidal- shaped, vaned components, the pump and turbine, immersed in fluid (usually oil). The pump or driving torus (the latter a General Motors automotive term) is rotated by the prime mover, which is typically an internal combustion engine or electric motor. The pump's motion imparts a relatively complex centripetal motion to the fluid. Simplified, this is a centrifugal force that throws the oil outwards against the coupling's housing, whose shape forces the flow in the direction of the turbine or driven torus (the latter also a General Motors term).

Here, Coriolis force reaction transfers the angular fluid momentum outward and across, applying torque to the turbine, thus causing it to rotate in the same direction as the pump. The fluid leaving the center of the turbine returns to the pump, where the cycle endlessly repeats. The pump typically is connected to the flywheel of the engine—in fact, the coupling's enclosure may be part of the flywheel proper, and thus is turned by the engine's crankshaft. The turbine is connected to the input shaft of the transmission. As engine speed increases while the transmission is in gear, torque is transferred from the engine to the input shaft by the motion of the fluid, propelling the vehicle. In this regard, the behavior of the fluid coupling strongly resembles that of a mechanical clutch driving a manual transmission.

A torque converter differs from a fluid coupling in that it provides a variable amount of torque multiplication at low engine speeds, increasing "breakaway" acceleration. This is accomplished with a third member in the "coupling assembly" known as the stator, and by altering the shapes of the vanes inside the coupling in such a way as to curve the fluid's path into the stator. The stator captures the kinetic energy of the transmission fluid in effect using the left-over force of it to enhance torque multiplication.



Tiptronic transmission is a special type of automatic transmission with a computer controlled automatic shift. The driver can switch the transmission to manual mode, which lets her shift the gear at her wish sequentially up (+) or down (-) without disengaging the clutch. This works just like a manual transmission; however, it still uses a torque converter to transfer power from the engine. Unfortunately, this is less efficient than a manual transmission.



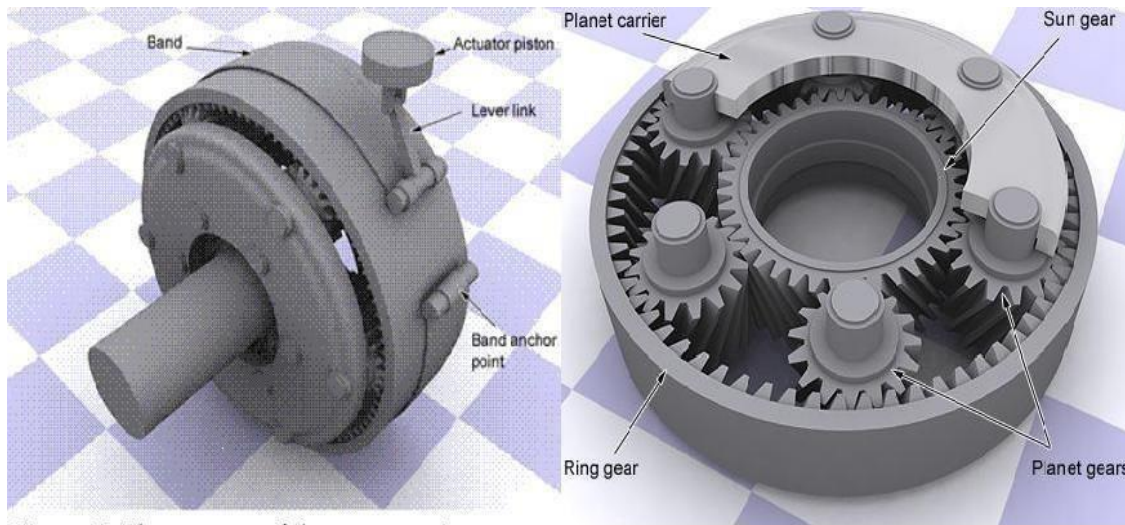
*Fig: Torque converter*

Planetary Gear-Set: - The automatic system for current automobiles uses a planetary gear set instead of the traditional manual transmission gear set. The planetary gear set contains four parts: sun gear, planet gears, planet carrier, and ring gear. Based on this planetary set design, sun gear, planet carrier, and ring gear spin centrifugally. By locking one of them, the planetary set can generate three different gear ratios, including one reverse gear, without engaging and disengaging the gear set. The gear set is actuated by hydraulic servos controlled by the valve body, providing two or more gear ratios.

Clutch Packs And Bands: - A clutch pack consists of alternating disks that fit inside a clutch drum. Half of the disks are steel and have splines that fit into grooves on the inside of the drum.



The other half have a friction material bonded to their surface and have splines on the inside edge that fit grooves on the outer surface of the adjoining hub. There is a piston inside the drum that is



*Figure 12: The structure of the actuator piston, lever link, and band system.*

**Figure 10** Planetary Gear Set.

activated by oil pressure at the appropriate time to squeeze the clutch pack together so that the two components become locked and turn as one.

A band is a steel strap with friction material bonded to the inside surface. One end of the band is anchored against the transmission case while the other end is connected to a servo. At the appropriate time hydraulic oil is sent to the servo under pressure to tighten the band around the drum to stop the drum from turning.

The bands come into play for manually selected gears, such as low range or reverse, and operate on the planetary drum's circumference. Bands are not applied when drive/overdrive range is selected, the torque being transmitted by the sprag clutches instead.

The sun gear is connected to a drum, which can be locked by a band. The ring gear is directly connected to the input shaft, which transfers power from the engine. The planet carrier is connected to the output shaft, which transfers power into the wheels.

Based on this design, when in neutral, both band and clutch sets are released. Turning the ring gear can only drive planet gears but not the planet carrier, which stays static if the car is not moving. The planet gears drive the sun gear to spin freely. In this situation, the input shaft is not able to transfer power to the output shaft. When shifting to 1st gear, the band locks the sun gear by locking the drum.



The ring gear drives the planet carrier to spin. In this situation, the ring gear (input shaft) spins faster than the planet carrier (output shaft).

To shift to higher gear, the band is released and the clutch is engaged to force the sun gear and planet carrier (output shaft) to spin at the same speed. The input shaft will also spin at the same speed as the output shaft, which makes the car run faster than in 1st gear. Using a compound planetary gear set generates more gear ratios with a special gear ratio, over-drive gear whose gear ratio is small than 1.

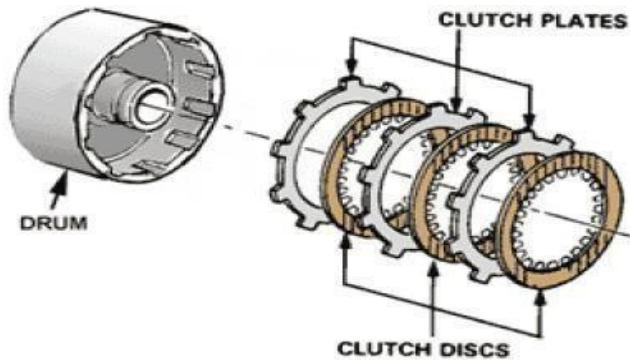
This will make the gear shift smoother. Both the band and clutch piston are pressurized by the hydraulic system. The part connecting the band or clutches to the hydraulic system is called the shift valve, while the one connecting the hydraulic system to the output shaft is called the governor.

The governor is a centrifugal sensor with a spring loaded valve. The faster the governor spins, the more the valve opens. The more the valve opens, the more the fluid goes through and the higher the pressure applied on the shift valve. Therefore, each band and clutch can be pushed to lock the gear based on a specific spin speed detected by the governor from the output shaft. To make the hydraulic system work efficiently, a complex maze of passages was designed to replace a large number of tubes. For modern cars, an electronic con-trolled (computer controlled) solenoid pack is used to detect throttle position, vehicle speed, engine speed, engine load, brake pedal position, etc., and to automatically choose the best gear for a moving vehicle.

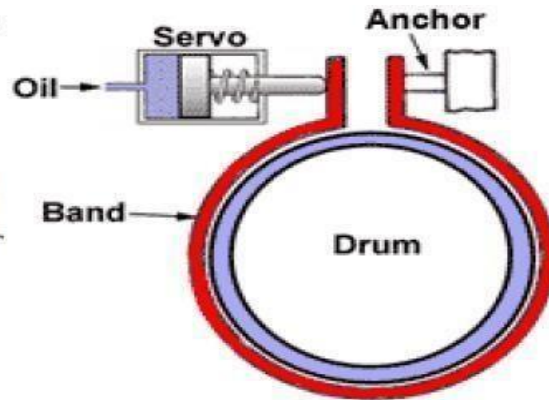
Principally, a type of device known as a sprag or roller clutch is used for routine upshifts/downshifts. Operating much as a ratchet, it transmits torque only in one direction, freewheeling or "overrunning" in the other. The advantage of this type of clutch is that it eliminates the sensitivity of timing a simultaneous clutch release/apply on two planetaries, simply "taking up" the drivetrain load when actuated, and releasing automatically when the next gear's sprag clutch assumes

the torque

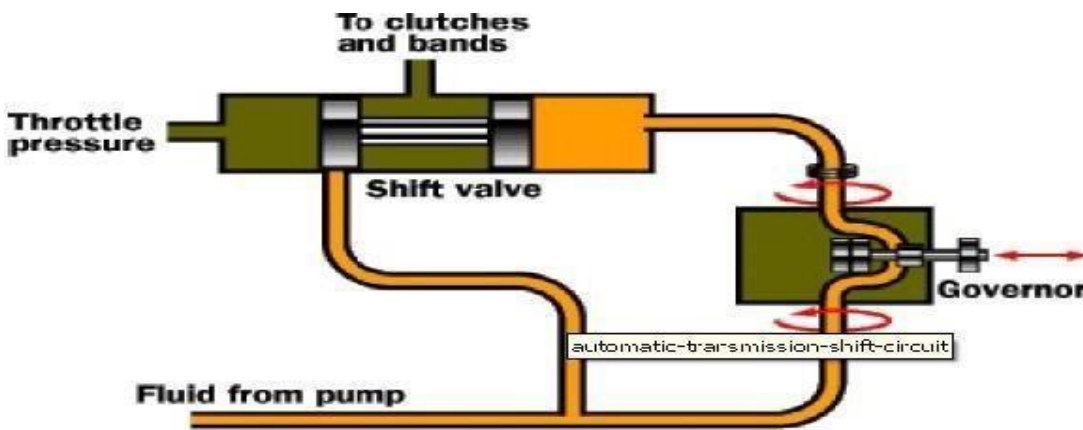




*Fig: CLUTCH PACKS*



*Fig: BANDS*



*Fig: Hydraulic System*

Valve Body: - Hydraulic control center that receives pressurized fluid from a main pump operated by the fluid coupling/torque converter. The pressure coming from this pump is regulated and used to run a network of spring-loaded valves, check balls and servo pistons.

The valves use the pump pressure and the pressure from a centrifugal governor on the output side (as well as hydraulic signals from the range selector valves and the throttle valve or modulator) to control which ratio is selected on the gearset; as the car and engine change speed, the difference between the pressures changes, causing different sets of valves to open and close.

Each of the many valves in the valve body has a specific purpose and is named for that function. For example the 2-3 shift valves activate the 2nd gear to 3rd gear up-shift or the 3-2 shift timing valve which determines when a downshift should occur.

The hydraulic pressure controlled by these valves drives the various clutch and brake band actuators, thereby controlling the operation of the planetary gearset to select the optimum gear ratio for the



current operating conditions. However, in many modern automatic transmissions, the valves are controlled by electro-mechanical servos which are controlled by the Engine Management System or a separate transmission controller.

The most important valve and the one that you have direct control over is the manual valve. The manual valve is directly connected to the gear shift handle and covers and uncovers various passages depending on what position the gear shift is placed in. When you place the gear shift in Drive, for instance, the manual valve directs fluid to the clutch pack(s) that activates 1st gear.

It also sets up to monitor vehicle speed and throttle position so that it can determine the optimal time and the force for the 1 - 2 shifts. On computer controlled transmissions, you will also have electrical solenoids that are mounted in the valve body to direct fluid to the appropriate clutch packs or bands under computer control to more precisely control shift points.

**Hydraulic & Lubricating Oil:** - A component called Automatic Transmission Fluid (ATF) which is part of the transmission mechanism provides lubrication, corrosion prevention, and a hydraulic medium to convey mechanical power.

Primarily it is made of refined petroleum and processed to provide properties that promote smooth power transmission and increase service life. ATF is one of the parts of the automatic transmission that needs routine service as the vehicle ages.

### **Differential Unit:**

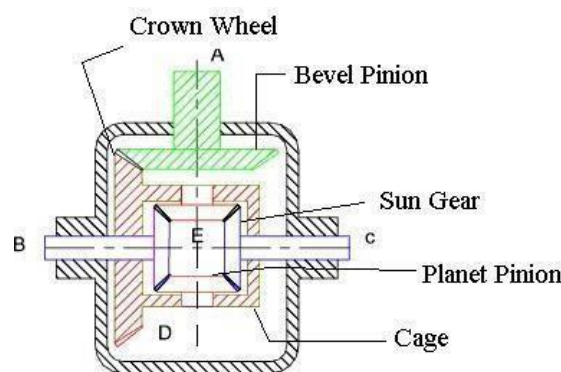
Differentials are a variety of gearbox, almost always used in one of two ways. In one of these, it receives one input and provides two outputs; this is found in every automobile. In automobile and other wheeled vehicles, the differential allows each of the driving wheels to rotate at different speeds, while supplying equal torque to each of them. In the other, less commonly encountered, it combines two inputs to create an output that is the sum (or difference) of the inputs. In automotive applications, the differential and its housing are sometimes collectively called a "pumpkin" (because the housing resembles a pumpkin).



## Purpose:-

The differential gear box has following functions:

- Avoid skidding of the rear wheels on a road turning.
- Reduces the speed of inner wheels and increases the speed of outer wheels, while drawing a curve.
- Keeps equal speeds of all the wheels while moving on a straight road.
- Eliminates a single rigid rear axle, and provides a coupling between two rear axles.



***Fig: Differential gear Assembly***

The following description of a differential applies to a "traditional" rear- or front-wheel-drive car or truck:

Power is supplied from the engine, via the transmission or gearbox, to a drive shaft termed as propeller shaft, which runs to the differential. A spiral bevel pinion gear at the end of the propeller shaft is encased within the differential itself, and it meshes with the large spiral bevel ring gear termed as crown wheel. The ring and pinion may mesh in hypoid orientation.

The ring gear is attached to a carrier, which holds what is sometimes called a spider, a cluster of four bevel gears in a rectangle, so each bevel gear meshes with two neighbors and rotates counter to the third that it faces and does not mesh with. Two of these spider gears are aligned on the same axis as the ring gear and drive the half shafts connected to the vehicle's driven wheels.

These are called the side gears. The other two spider gears are aligned on a perpendicular axis which changes orientation with the ring gear's rotation. These two gears are just called pinion gears, not to



be confused with the main pinion gear.

As the carrier rotates, the changing axis orientation of the pinion gears imparts the motion of the ring gear to the motion of the side gears by pushing on them rather than turning against them (that is, the same teeth stay in contact), but because the spider gears are not restricted from turning against each other, within that motion the side gears can counter-rotate relative to the ring gear and to each other under the same force (in which case the same teeth do not stay in contact).

Thus, for example, if the car is making a turn to the right, the main ring gear may make 10 full rotations. During that time, the left wheel will make more rotations because it has further to travel, and the right wheel will make fewer rotations as it has less distance to travel. The side gears will rotate in opposite directions relative to the ring gear by, say, 2 full turns each (4 full turns relative to each other), resulting in the left wheel making 12 rotations, and the right wheel making 8 rotations.

The rotation of the ring gear is always the average of the rotations of the side gears. This is why if the wheels are lifted off the ground with the engine off, and the drive shaft is held (preventing the ring gear from turning inside the differential), manually rotating one wheel causes the other to rotate in the opposite direction by the same amount.

When the vehicle is traveling in a straight line, there will be no differential movement of the planetary system of gears other than the minute movements necessary to compensate for slight differences in wheel diameter, undulations in the road (which make for a longer or shorter wheel path), etc.

### **Hotchkiss drive;**

The Hotchkiss drive is a system of power transmission. It was the dominant form of power transmission for front-engine, rear-wheel drive layout cars in the 20th century. The name comes from the French automobile firm of Hotchkiss, although it is clear that other makers (such as Peerless) used similar systems before Hotchkiss.

During the early part of the 20th century the two major competing systems of power transmission were the shaft-drive and chain-drive configurations. The Hotchkiss drive is a shaft-drive system (another type of direct-drive transmission system is the torque tube, which was also popular until the



1950s).

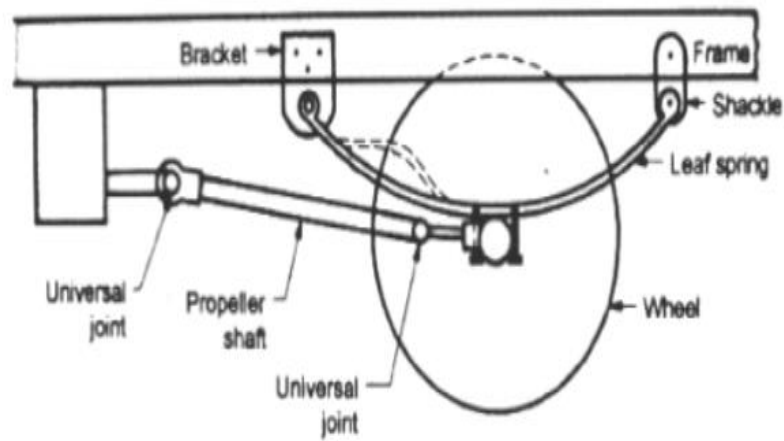
All shaft-drive systems consist of a driveshaft (also called a "propeller shaft" or Cardan shaft) extending from the transmission in front to the differential in the rear. The differentiating characteristic of the Hotchkiss drive is the fact that it uses universal joints at both ends of the driveshaft, which is not enclosed. The use of two universal joints, properly phased and with parallel alignment of the drive and driven shafts, allows the use of simple cross-type universals. (In a torque-tube arrangement only a single universal is used at the end of the transmission tail shaft, and this universal should be a constant velocity joint.)

In the Hotchkiss drive, slip-splines or a plunge-type (ball and trunnion u-joint) eliminate thrust transmitted back up the driveshaft from the axle, allowing simple rear-axle positioning using parallel leaf springs. (In the torque-tube type this thrust is taken by the torque tube to the transmission and thence to the transmission and motor mounts to the frame. While the torque-tube type requires additional locating elements, such as a Panhard rod, this allows the use of coil springs.)

Some Hotchkiss drive shafts are made in two pieces with another universal joint in the center for greater flexibility, typically in trucks and specialty vehicles built on truck frames. Some installations use rubber mounts to isolate noise and vibration. The 1984–1987 RWD Toyota Corolla (i.e., Corolla SR5 and GT-S) coupe is another example of a car that uses a 2-part Hotchkiss driveshaft with a rubber-mounted center bearing.

This design was the main form of power transmission for most cars from the 1920s through the 1970s. Presently (circa 2012), it remains common in pick-up trucks, and sport utility vehicles





Hotchkiss Drive

## Torque tube Drive

A torque tube system is a driveshaft technology, often used in automobiles with a front engine and rear drive. It is not as widespread as the Hotchkiss drive, but is still occasionally used to this day. Drive shafts are sometimes also used for other vehicles and machinery.

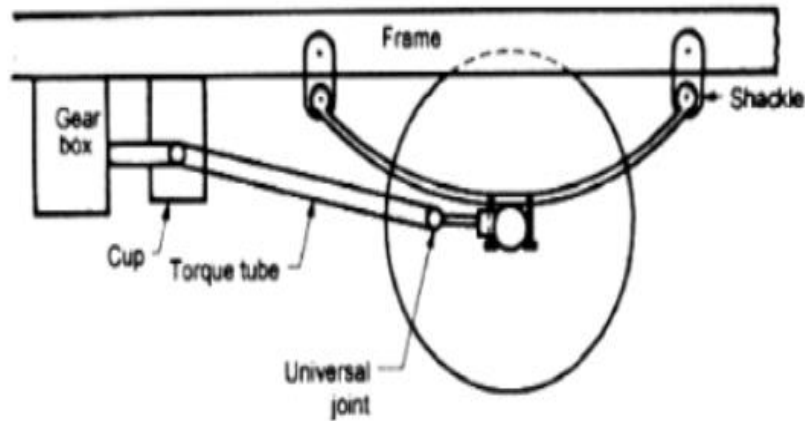
The "torque" that is referred to in the name is not that of the driveshaft, along the axis of the car, but that applied by the wheels. The design problem that the torque tube solves is how to get the traction forces generated by the wheels to the car frame. The "torque tube" transmits this force by directly coupling the axle differential to the transmission and therefore propels the car forward by pushing on the engine/transmission and then through the engine mounts to the car frame<sup>[citation needed]</sup>.

In contrast, the Hotchkiss drive has the traction forces transmitted to the car frame by using other suspension components such as leaf springs or trailing arms. A ball and socket type of joint called a "torque ball" is used at one end of the torque tube to allow relative motion between the axle and transmission due to suspension travel. Since the torque tube does not constrain the axle in the lateral (side-to-side) direction a pan hard rod is often used for this purpose. The combination of the pan hard rod and the torque tube allows the easy implementation of soft coil springs in the rear to give good ride quality.

In addition to transmitting the traction forces, the torque tube is hollow and contains the rotating driveshaft. Inside the hollow torque ball is the universal joint of the driveshaft that allows relative motion between the two ends of the driveshaft. In most applications the drive shaft uses a single



universal joint which has the disadvantage that it causes speed fluctuations in the driveshaft when the shaft is not straight. The Hotchkiss drive uses two universal joints which has the effect of canceling the speed fluctuations and gives a constant speed even when the shaft is no longer straight



**Torque tube drive**

Sr.	Hotchkiss Drive	Torque Tube Drive
1.	Open type propeller shaft is used.	Propeller shaft is housed in a tube called torque tube.
2.	Two universal joints is used one at front & second at rear end of the propeller shaft.	Only one universal joint is used at the front end of the propeller shaft.
3.	Slip joint is used to accommodate change in length.	No slip joint is used.
4.	Torque reaction, driving thrust, side thrust, weight of the body & braking torque all are taken by leaf spring.	Weight of the body & side thrust are taken by leaf spring. Torque reaction, driving thrust, braking torque are taken by the torque tube.
5.	Leaf spring is shackled at the rear and bracketed at front end.	Both end of the leaf spring are shackled.
6.	The centre axis of propeller shaft and bevel pinion shaft is not coinciding when axle moves up and down.	Axis of propeller shaft and bevel pinion shaft coincide always.
7.	It is used in heavy vehicles like bus, truck.	It is used in light vehicles like cars.





---

# UNIT IV

## STEERING, BRAKES AND SUSPENSION SYSTEMS

---



## Steering System

- Steering provides the directional change for the movement of the automobile and it maintain in a position as per the direction of the driver's decision with out strain on him.
- Steering is done by the movement of the axis of rotation of the front wheel with respect to chassis frame

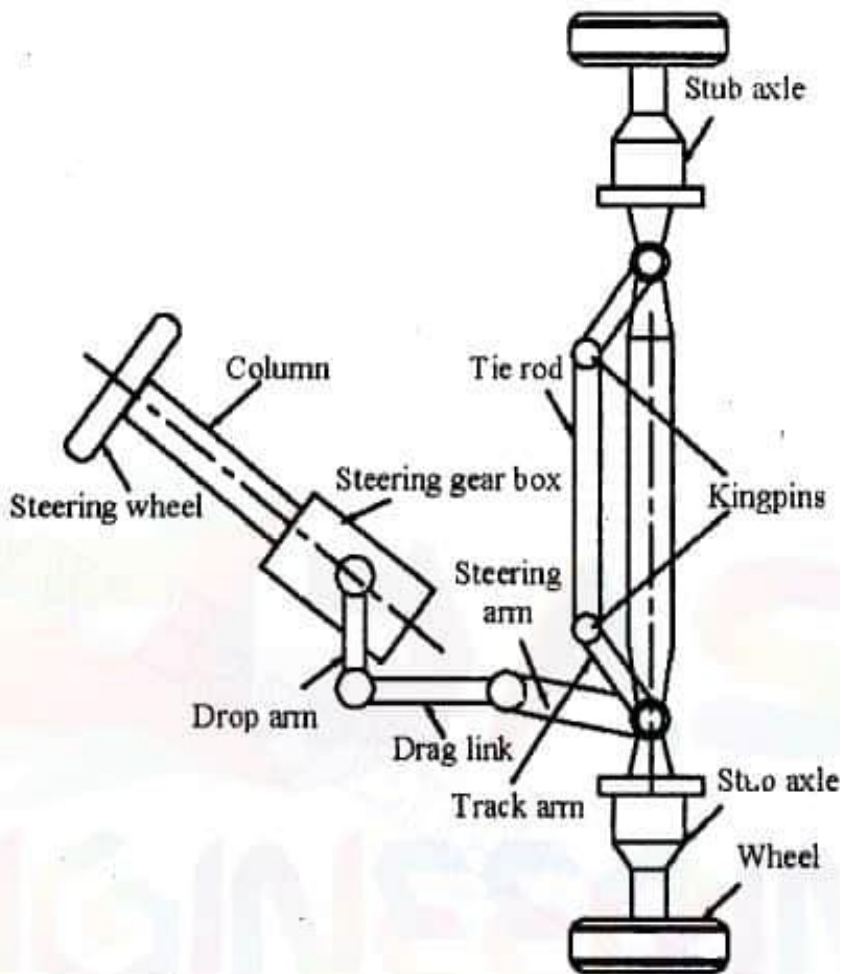
## Requirement of a Steering System

- It multiplies the turning effort applied on the steering wheel by the driver
- The shock of the road surface absorb by the wheels should not be transmitted to driver's hand.
- This system should be light and stable
- It should be easily operated with less maintenance

## Functions of a Steering Wheel

- It should provide wheel swing either left or right
- It provides vehicle turning as per the will of the driver
- It should provide direction stability
- It helps to control the wear and tear of the tyres.
- Allows for suspension action.
- 

## Layout of Steering system



## Steering Components

1. Steering Wheel
2. Steering Column
3. Steering Gear Box
4. Drop Arm
5. Ball Joint



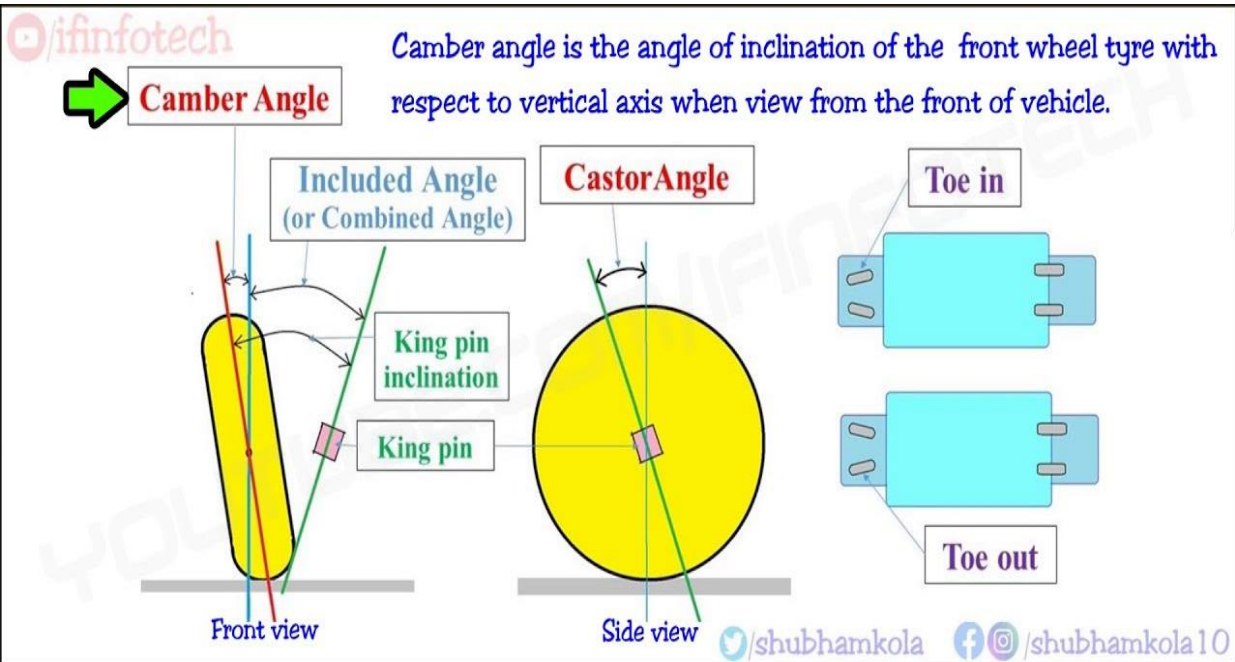
## Terminology

- The Steering Wheel – The Bit the driver holds on to! It also incorporates the Air Bag.
- Steering Column – The shaft connecting the steering wheel to the steering box or steering rack.
- Steering Rack – A combination of a small gear and a toothed rack. This changes the rotation of the steering wheel into a back and forth movement of the rack which in turn moves the road wheels.
- Steering Box – This does a similar job to the rack but needs extra linkages and rods to connect it to the road wheels. Mostly used on old cars, but still is in use on larger vehicles.
- Track rod/Tie rod – A rod to connect the left and right steered wheels. The steering rack is also the track rod.
- Track rod end – A ball joint to allow steering and suspension movement.
- Ball joint/Swivel joint – Part of the suspension, but these are joints which allow the steered wheels to left and right.
- PAS – Power assisted steering. An engine driven pump or electric motor, provides extra force to help the driver turn the steering.
- Tracking – toe in or toe out setting for the steered wheels.

### Steering Geometry

- Steering Geometry means it is the angular relationship among the front wheels, front wheel attaching parts and vehicle frame and road surface.
- The method of describing the measurement alignment of angles that affect steering is called steering geometry or wheel alignment.
- Various Angles that affect the Steering geometry are as follows
  1. Camber
  2. Caster
  3. King-Pin
  4. Toe-in and Toe out





## CASTER ANGLE

Caster angle is the tilt of the kingpin or ball joint centre line from the vertical towards either the front (negative caster) or rear (positive caster) of the vehicle.

The caster angle produces a trailing effect and hence gives the directional stability. In correct caster can produce difficulties like hard steering, pulling to one side when brakes are applied.

The caster angle ranges from 2-8° negative.

## CAMBER ANGLE

Camber angle is the inclination between the centre line of the tire and the vertical line. The outward inclination is called positive camber and the inward inclination is the negative camber. The purpose of the camber is to prevent the top of wheels from tilting inward much due to excessive load or play in the king-pin and wheel bearing. Unequal camber in the wheels causes the vehicles to roll in the direction of wheel having the greater camber which upsets directional stability and tends to scuff the tread on the opposite tire, excessive camber prevents the tire from having correct contact with the road which causes it to wear only on the side directly beneath the load.

- Camber angle is less than 1 degree

## KING-PIN INCLINATION

Kingpin inclination is the inward tilt of the kingpin or ball joint centerline from the vertical. Kingpin tilt in combination with curvature provides directional stability. whereas kingpin inclination and camber combine to give direction from the tire's centre point on the road and bring upthrust at the stub axle closest to the centre of the kingpin. The bending angle combined with the kingpin inclination is called the included angle.

The inclination of the kingpin varies from 4-8°.

## TOE-IN and TOE-OUT

The front wheels are usually designed a little forward so that the distance between the rear ends (y) is slightly greater than the distance between the front ends (x). The difference between these



distances is called convergence. The wheels are turned inwards to compensate for the tendency to roll outwards due to the curvature and play in the steering linkage. Convergence is usually 2 to 4 mm.

When a vehicle turns, the inner wheel of the vehicle moves faster as compared to the outer wheel because the former has to go around an area with a smaller radius than the latter. This action causes the wheels to turn due to differences in their turning angles.

## **Importance of Steering Geometry**

1. **Improve Handling:** - This helps in controlling the vehicle. Improper handling can be due to vehicle pulling on one side, vibration of the steering wheel.
2. **Improves tyre life and performance:** - Proper rolling tyre contact on road and prevention of slipping of the tyres due to improper alignment results in better tyre life.
3. **Helps in identifying problems:** - Improper alignment could be a symptom of something wrong in the vehicle. A check on this can lead to correction in the fault in the vehicle.
4. **Ensures Safety:** - By keeping the system in order by removing the defective parts, enhances the vehicle systems, especially the suspension system, leading to better safety.
5. **Improves fuel efficiency:** - By enhancing the performance of various systems, leads to better fuel efficiency from the vehicle.

## **Function of Steering Gear Box**

The rotary motion of steering wheel is converted to straight liner motion of a linkage by a steering gear

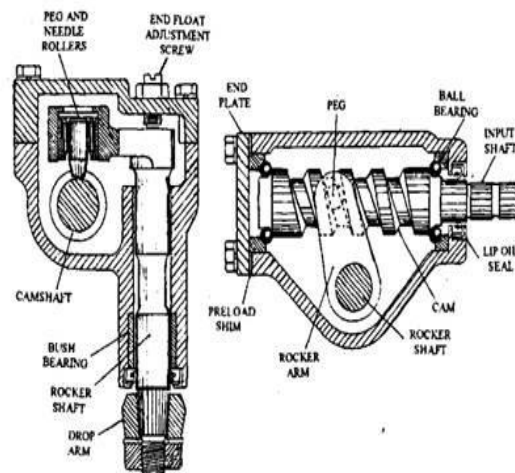
The type of a gear used to convert the motion is worm gear

## **Types of Steering Gear box**

1. Cam and Roller
2. Recirculating Ball
3. Rack and Pinion
4. Power-Steering



## Cam and Roller Steering Gear Box



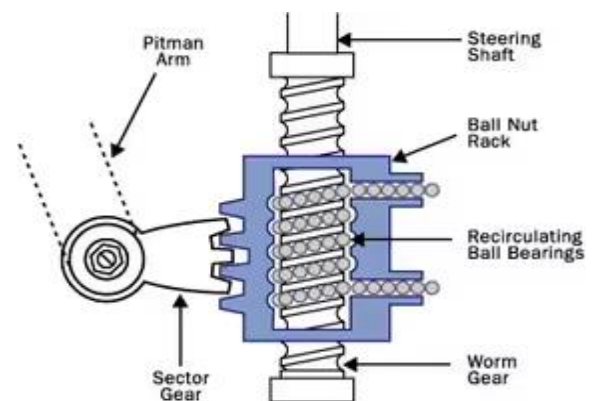
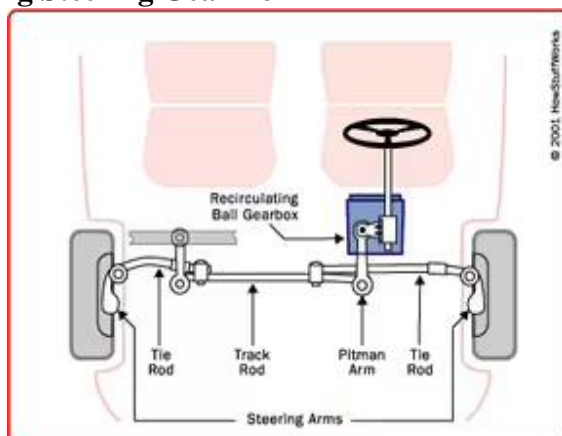
### Construction

- The cam and roller steering boxes are very efficient.
- The cam is carried by the steering shaft connected with rollers.
- The drop arm spindle carries the vee shaped roller.
- This spindle is carried by ball bearings in the casing.
- The meshing member contains the spiral grooves. The centre position of the pin supports the roller.

### Working

- By moving the steering wheel and steering shaft, the cam is rotated.
- Due to this rotation, the roller is constrained to follow the helix of the groove.
- When the cam rotates, the roller is followed the cam and made the rocker shaft to rotate.
- The contour of the cam is properly designed to match with our aim.

## Recirculating Steering Gear Box

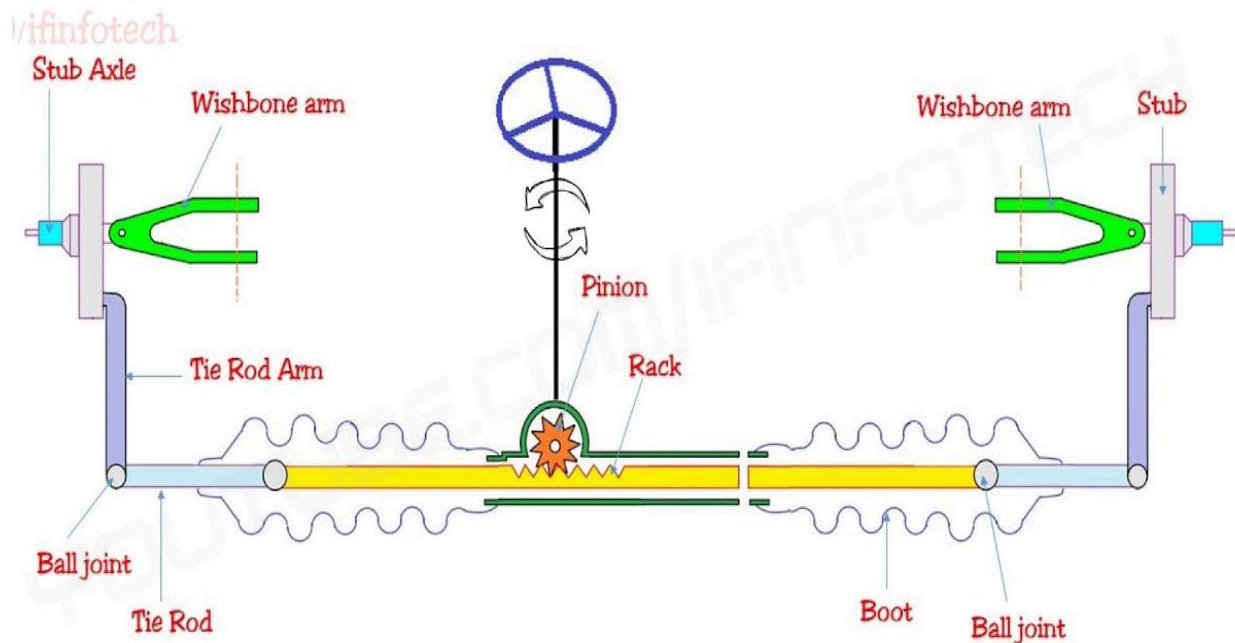


Recirculating-ball steering is used on many trucks and SUVs today. The linkage that turns the wheels is slightly different than on a rack-and-pinion system.

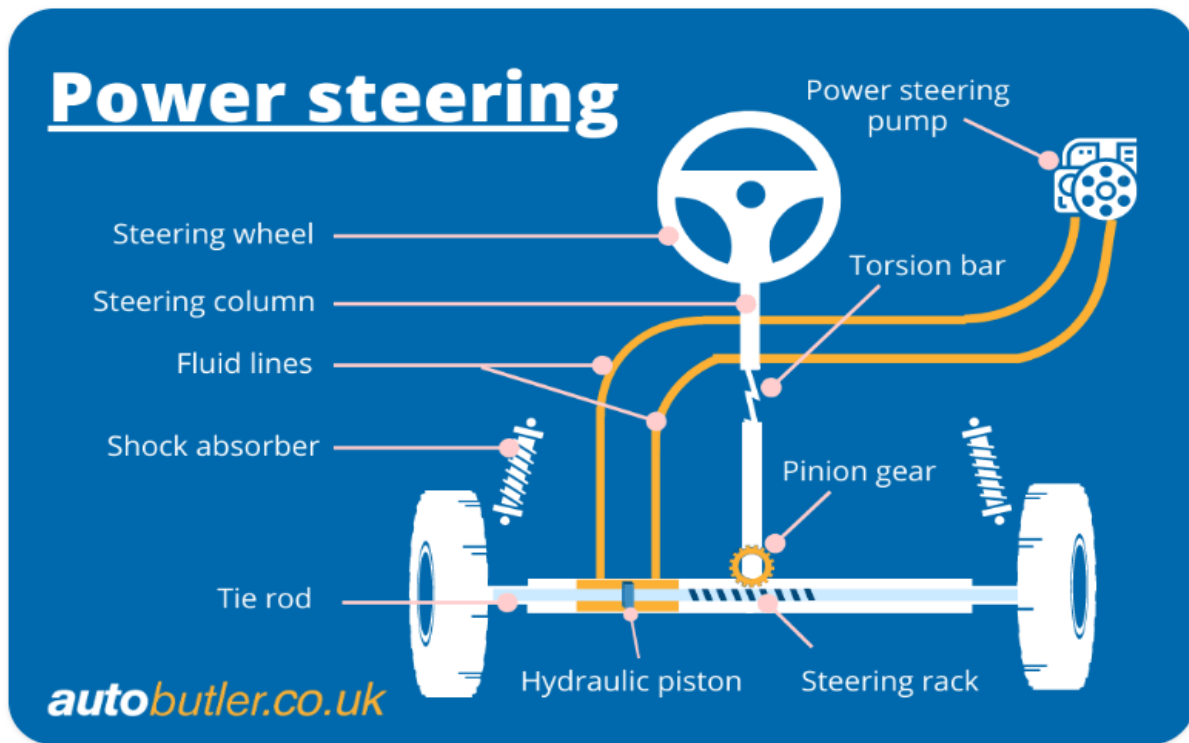
The recirculating-ball steering gear contains a [worm gear](#). You can image the gear in two parts. The first part is a block of metal with a threaded hole in it. This block has gear teeth cut into the outside of it, which engage a gear that moves the pitman arm (see diagram above). The steering wheel connects to a threaded rod, similar to a bolt, that sticks into the hole in the block. When the steering wheel turns, it turns the bolt. Instead of twisting further into the block the way a regular bolt would, this bolt is held fixed so that when it spins, it moves the block, which moves the gear that turns the wheels

## Rack and Pinion Steering Gear Box

- Rack & pinion is on the vast majority of today's vehicles, and has been for the last few decades. It's simple, compact, direct, and provides great steering feel. On this type of system, a toothed pinion gear mounted on the bottom of your steering column turns with the steering wheel. As that pinion gear rotates, it comes in contact with the “rack” (a long bar with teeth cut into it) – causing the rack to slide left or right. As the rack bar moves, your front wheels turn accordingly. Tie rod ends at each side of the vehicle provide the final connection between the steering rack and front wheels. They're designed to flex in many directions to allow for up-and-down movement over bumps, and they can be adjusted in order to reset front wheels straight during an alignment.

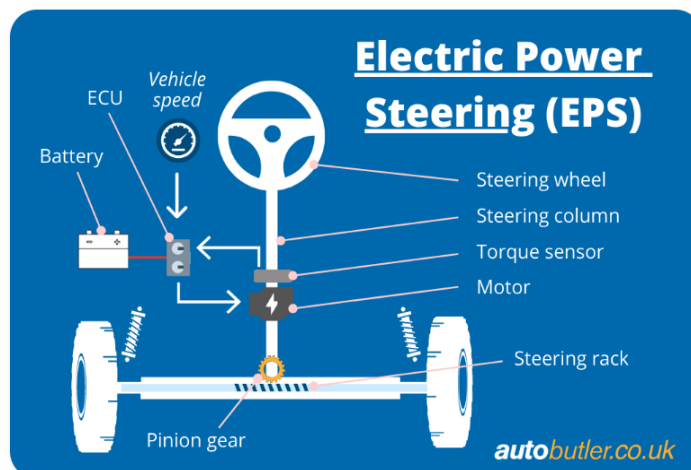


## Hydraulic power steering



- Hydraulic power steering is a closed system composed of several elements: A motor-driven power steering pump creates hydraulic pressure using a compressed oil - **power steering fluid**. A power steering belt connected to **the crankshaft** drives the pump.
- The power steering pump leads the compressed fluid from its small reservoir in the engine via closed pipes down to the steering rack that connects the car's two front wheels. It is inside the steering rack that the power steering fluid creates the hydraulic mechanism: A piston pushes the fluid back and forth, depending on the movement of the steering wheel. The piston is assisted by the small pinion gear, which reacts when the steering wheel is turned.
- The whole mechanism is designed to amplify smaller levels of force applied by the driver when turning the steering wheel, so that it becomes much easier to turn with less effort.

## Electric power steering



- Electric power steering is a more recent design compared to the hydraulic system. However, it has exactly the same function - to support the movement of the steering wheel, so that the driver can more easily manoeuvre the car without having to use a lot of force. The system is connected to [the car's battery](#).
- In an electric power steering system, it is [the car's computer](#) (ECU) that signals the mechanism to turn the steering wheel. The force is generated by an electric motor that often sits by the steering rack and helps move the pinion gear back and forth inside the rack. In a car with electric power steering, the type of rack is a little different, as it is not connected to a closed, hydraulic system with pipes.
- There are several auxiliary mechanisms in this system. The ECU receives a signal from the car regarding speed, and a torque sensor tells the system how much force is applied to turn the steering wheel. Together, the many sensors adjust the electric power steering.

### **Suspension system;**

Suspension system is the term given to the system of springs, shock absorbers and linkages that connects a vehicle to its wheels. It is basically cushioned for passengers protects the luggage or any cargo and also itself from damage and wear.

Sir **William Brush** is the father of suspension system in automobiles.

### **The main role of suspension system is as follows:**

- It supports the weight of vehicle.
- Provides smoother ride for the driver and passengers i.e. acts as cushion.
- Protects your vehicle from damage and wear.
- It also plays a critical role in maintaining self driving conditions.
- It also keeps the wheels pressed firmly to the ground for traction.
- It isolates the body from road shocks and vibrations which would otherwise be transferred to the passengers and load.

### **Principle:**

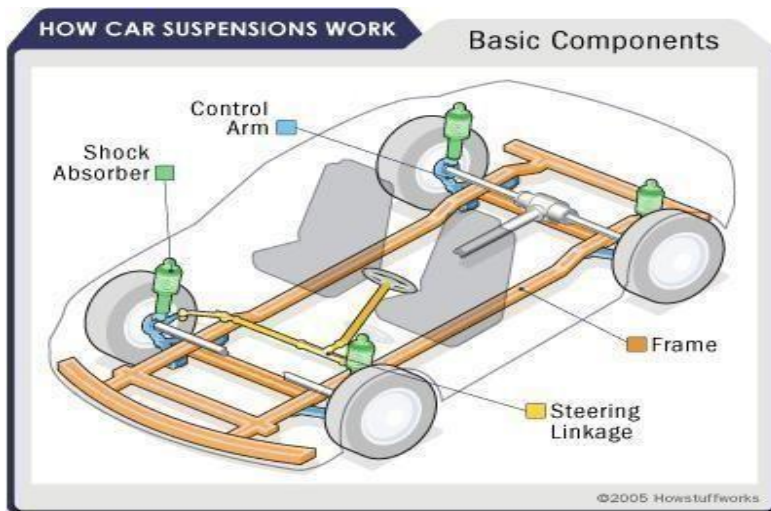
When a tire hits an obstruction, there is a reaction force. The size of this reaction force depends on the unsprung mass at each wheel assembly.

In general, the larger the ratio of sprung weight to unsprung weight, the less the body and vehicle occupants are affected by bumps, dips, and other surface imperfections such as small bridges. A large sprung weight to unsprung weight ratio can also impact vehicle control.

No road is perfectly flat i.e. without irregularities. Even freshly paved highways have



subtle imperfections that can be interact with vehicle's wheels. These are the imperfections that apply forces on wheels.

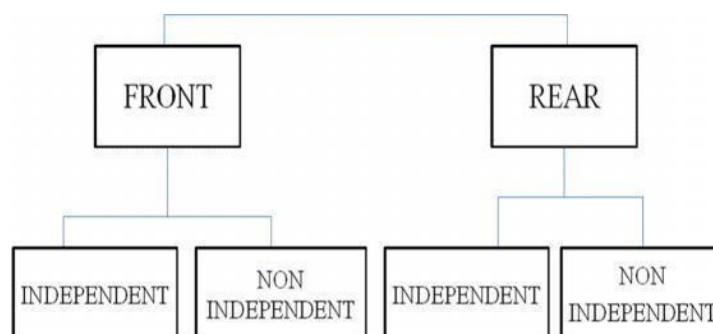


### Components of Suspension system;

There are three fundamental components of any suspension system.

- Springs
  - Coil spring
  - Leaf springs
  - Air springs
- Dampers
  - Shock Absorbers
  - Struts
- Anti sway bars.

### Types of Suspension system;

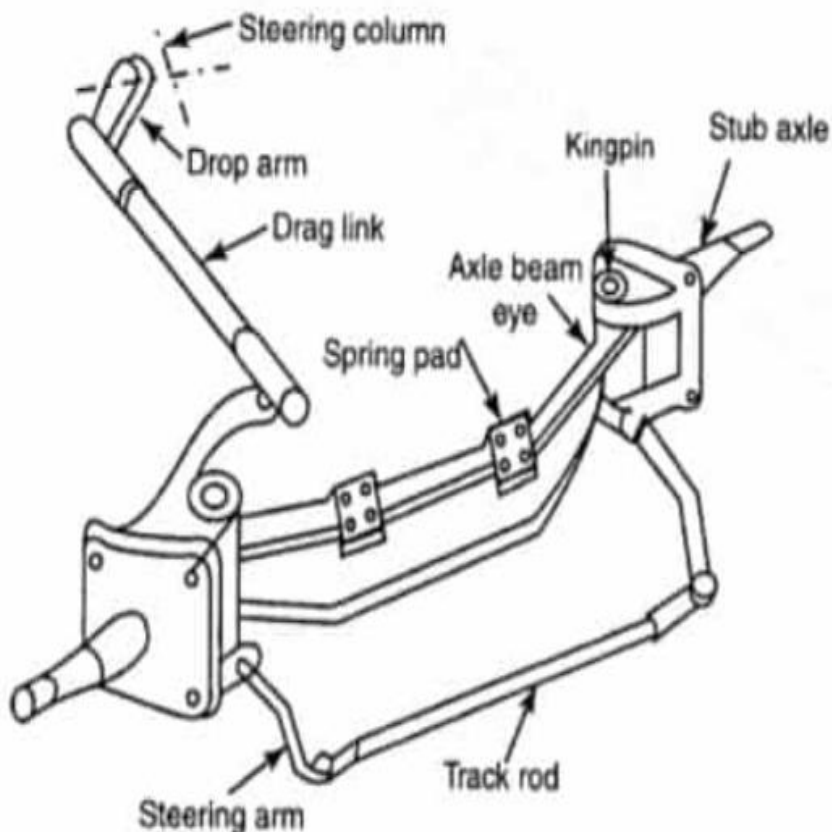


## Advantages;

- Comfort to passengers
- Good handling
- Shields the vehicle from damage
- Increases life of vehicle
- Keeps the tires pressed firmly to ground.

## FRONT AXLE

- The major unit on front part of the motor vehicle is front axle. It takes the weight of the front portion of the automobile. It gives steering facility and absorbs shocks. The weight of the front part of the vehicle is transmitted to the road surface through front wheels by the front axle of a vehicle. It also houses the mechanism for steering the vehicle to absorb shocks due to road surface variations.



- Axle beam is a major part of the front axle. It is used to transmit the vehicle weight to the front wheel through the spring. A typical front axle shown in Figure 4.31 elaborates the front axle components with steering linkage.
- The components of the front axle are axle beam, stub axle, swivel pin and track load
- The ends of the axle beam are shaped in such way to assemble the stub axle. The ends of the axle beam are shaped either as a yoke or plain surface with drilled hole to hold a swivel pin connecting



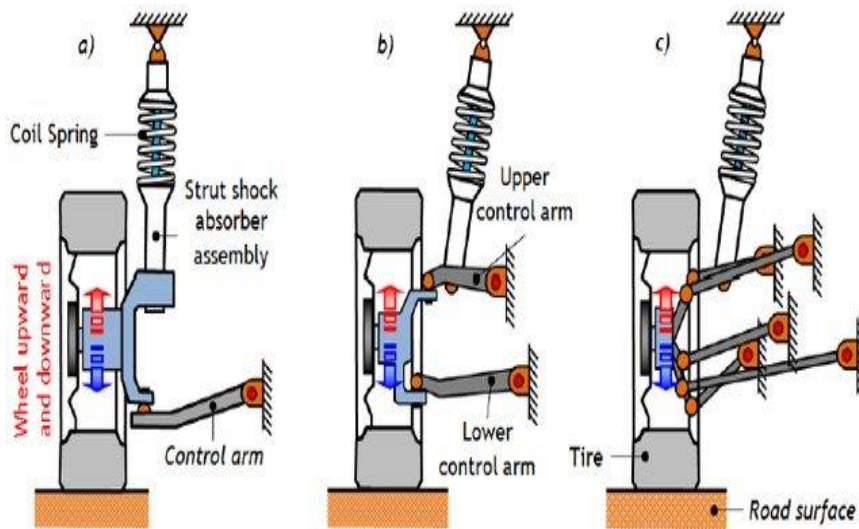
the stub axle portion of the assembly. The wheels are connected on stub axles. The inclined steering arms are located to track rod ends. The third steering arm is connected to the drag link. The steering linkage is connected by the drag link to the drop arm of the steering box. The main axle beam is attached to stub axles by kingpins. The front road wheels are connected on these stub axles.

### Types of Rear Suspension System

Suspension systems vary by vehicle body type and, in certain cases, even by brand. Here are the eight most common car suspensions you'll come across.

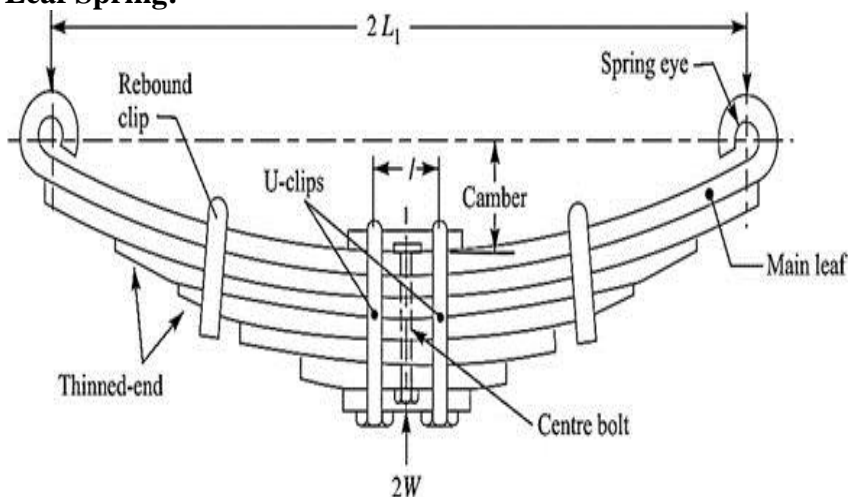
- Independent Suspension
- Rigid Suspension or Leaf Spring
- Multi-Link Suspension
- Rigid Axle Suspension
- Air Suspension System

### Independent Suspension



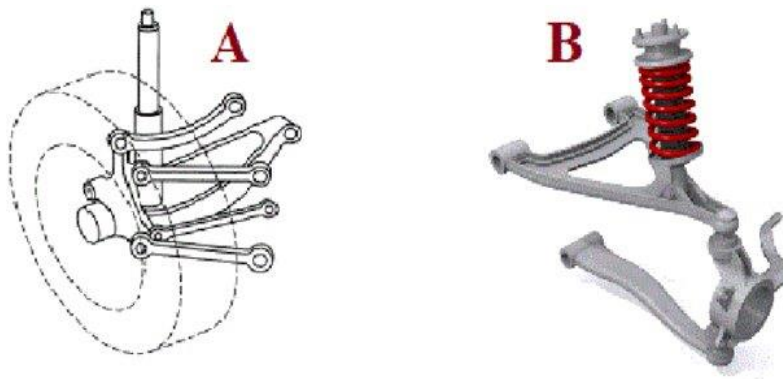
- Independent suspension refers to a suspension system that is installed on each wheel separately. This means that bumps encountered by one wheel are unaffected by those experienced by the others. As a result, the ride and control are extremely comfortable. The Macpherson Strut, Double Wishbone Suspension, and Multi-link Suspension are some of the suspensions that use this technique.

### Rigid Suspension or Leaf Spring:



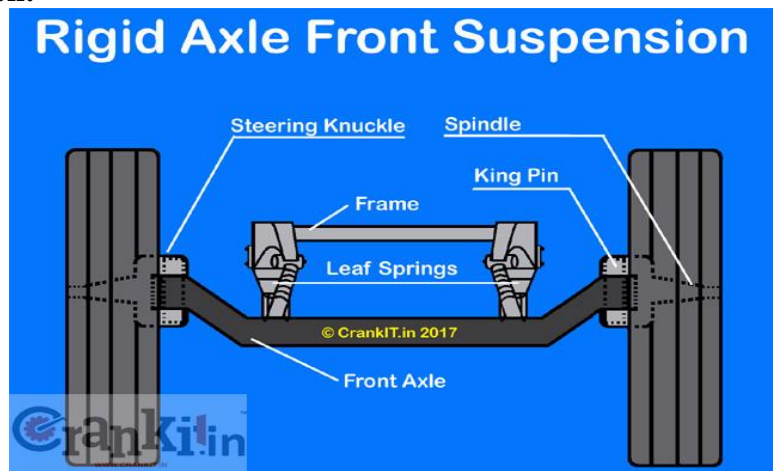
- The leaf spring rigid suspension, like the beam axle suspension in construction, uses leaf springs instead of coil springs to act as dampers. Leaf springs are large bundles of spring material, mostly steel, that flex as the vehicle's axle is pressed on them. Leaf springs are perfect for use in commercial vehicles since they can support a lot of weight without breaking a sweat. However, they are not designed for comfort, high speed, or fast turning, and if used under those conditions, the suspension will alter vehicle handling.

### Multi-Link Suspension:



This form of suspension features several links connecting to the automobile chassis and wheel assembly, as the name implies. Because these many links can respond to any force applied to them, they're also employed in off-road vehicles. On the rear tires, multi-Link suspension systems are used to provide a highly comfortable ride and good grip. This suspension will keep your wheels attached to the ground in the event of a rapid turn. Due to their intricate construction, these suspensions are only found on high-end vehicles, and any damage necessitates a time-consuming and costly repair.

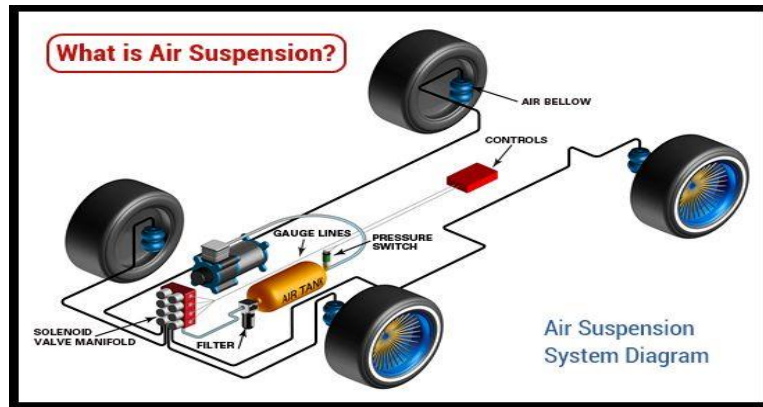
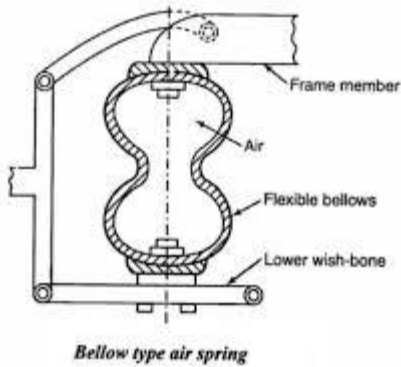
### Rigid Axle Suspension:



The rigid axle suspension, also known as beam axle suspension, has a perpendicular axle that is attached to the wheels by a wheel spindle and can be used with leaf springs or coiled springs. A stiff axle is extremely sturdy and capable of carrying a significant amount of weight. The rigid axle suspension, unlike most current suspensions, has a very simple configuration that makes it straightforward to fix and replace. Because of its load-carrying capability and improved articulation, this suspension and its modified versions are employed in heavy-duty vehicles and off-roaders. However, these suspensions are not designed for fast speeds or sharp turns, and if subjected to heavy cornering, the cars will rollover.



## Air Suspension System:



- Air suspension, often known as air springs, is a type of suspension that uses air bellows instead of coils and dampers. These air bellows can be inflated and deflated with the help of an air compressor to alter the vehicle's ride height. Air suspension is one of the most comfortable and load-bearing suspensions available, which is why it is found in the majority of high-end luxury and sports automobiles. Many vehicles and buses utilize them because of their weight carrying capabilities. Air suspensions are extremely adaptable, and when combined with an onboard computer, they can adjust to any height, load, or passenger.

## Braking System;

A brake is a mechanical device which inhibits motion, slowing or stopping a moving object or preventing its motion. The rest of this article is dedicated to various types of vehicular brakes. Most commonly brakes use friction between two surfaces pressed together to convert the kinetic energy of the moving object into heat, though other methods of energy conversion may be employed. For example regenerative braking converts much of the energy to electrical energy, which may be stored for later use. Other methods convert kinetic energy into potential energy in such stored forms as pressurized air or pressurized oil. Eddy current brakes use magnetic fields to convert kinetic energy into electric current in the brake disc, fin, or rail, which is converted into heat. Still other braking methods even transform kinetic energy into different forms, for example by transferring the energy to a rotating flywheel.

Brakes are generally applied to rotating axles or wheels, but may also take other forms such as the surface of a moving fluid (flaps deployed into water or air). Some vehicles use a combination of braking mechanisms, such as drag racing cars with both wheel brakes and a parachute, or airplanes with both wheel brakes and drag flaps raised into the air



during landing.

Since kinetic energy increases quadratically with velocity ( $k=mv^2/2$ ) an object moving at 10 m/s has 100 times as much energy as one of the same mass moving at 1 m/s, and consequently the theoretical braking distance, when braking at the traction limit, is 100 times as long. In practice, fast vehicles usually have significant air drag, and energy lost to air drag rises quickly with speed. Almost all wheeled vehicles have a brake of some sort. Even baggage carts and shopping carts may have them for use on a moving ramp. Most fixed-wing aircraft are fitted with wheel brakes on the undercarriage. Some aircraft also feature air brakes designed to reduce their speed in flight.

Notable examples include gliders and some World War II-era aircraft, primarily some fighter aircraft and many dive bombers of the era. These allow the aircraft to maintain a safe speed in a steep descent. The Saab B 17 dive bomber and Vought F4U Corsair fighter used the deployed undercarriage as an air brake. Friction brakes on automobiles store braking heat in the drum brake or disc brake while braking then conduct it to the air gradually. When traveling downhill some vehicles can use their engines to brake.

When the brake pedal of a modern vehicle with hydraulic brakes is pushed, ultimately a piston pushes the brake pad against the brake disc which slows the wheel down. On the brake drum it is similar as the cylinder pushes the brake shoes against the drum which also slows the wheel down. Brakes may be broadly described as using friction, pumping, or electromagnetic. One brake may use several principles: for example, a pump may pass fluid through an orifice to create friction: Frictional brakes are most common and can be divided broadly into "shoe" or "pad" brakes, using an explicit wear surface, and hydrodynamic brakes, such as parachutes, which use friction in a working fluid and do not explicitly wear. Typically the term "friction brake" is used to mean pad/shoe brakes and excludes hydrodynamic brakes, even though hydrodynamic brakes use friction.

Friction (pad/shoe) brakes are often rotating devices with a stationary pad and a rotating wear



surface. Common configurations include shoes that contract to rub on the outside of a rotating drum, such as a band brake; a rotating drum with shoes that expand to rub the inside of a drum, commonly called a "drum brake", although other drum configurations are possible; and pads that pinch a rotating disc, commonly called a "disc brake".

Other brake configurations are used, but less often. For example, PCC trolley brakes include a flat shoe which is clamped to the rail with an electromagnet; the Murphy brake pinches a rotating drum, and the Ausco Lambert disc brake uses a hollow disc (two parallel discs with a structural bridge) with shoes that sit between the disc surfaces and expand laterally. Pumping brakes are often used where a pump is already part of the machinery. For example, an internal-combustion piston motor can have the fuel supply stopped, and then internal pumping losses of the engine create some braking. Some engines use a valve override called a Jake brake to greatly increase pumping losses. Pumping brakes can dump energy as heat, or can be regenerative brakes that recharge a pressure reservoir called a hydraulic accumulator.

Electromagnetic brakes are likewise often used where an electric motor is already part of the machinery. For example, many hybrid gasoline/electric vehicles use the electric motor as a generator to charge electric batteries and also as a regenerative brake. Some diesel/electric railroad locomotives use the electric motors to generate electricity which is then sent to a resistor bank and dumped as heat.

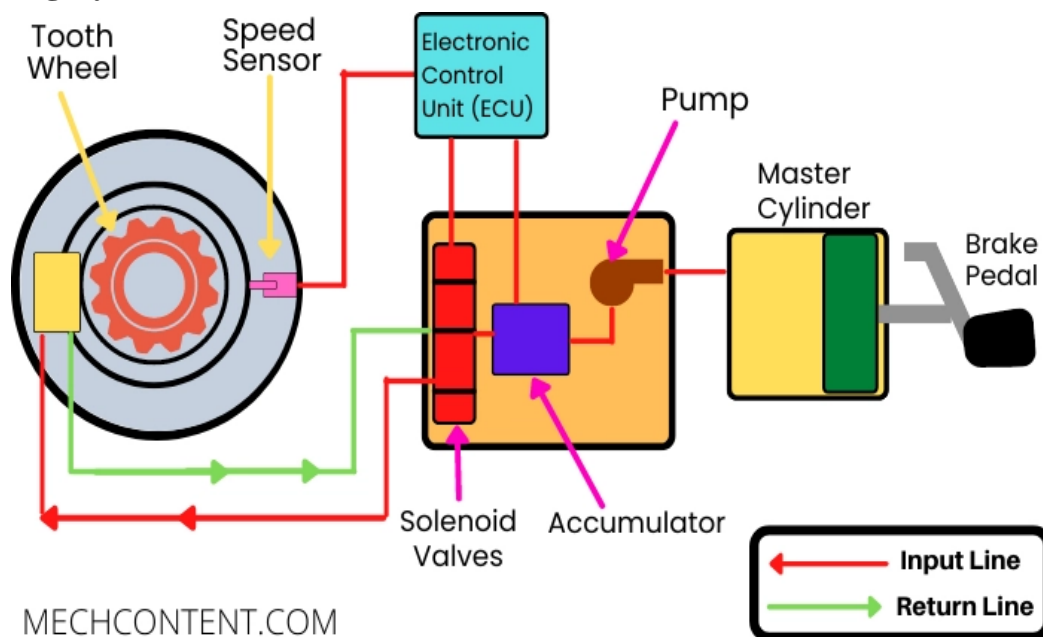
### **Types of Braking system in Automobile;**

- By applications –
  1. Foot Brake,
  2. Hand brake.
- By Method of power –
  1. Mechanical brake,
  2. Hydraulic brake.
  3. Vacuum brake,



4. Electrical brake and
  5. Air brake.
- By method of operations –
    1. Manual brake,
    2. Servo brake.
    3. Power operation.
  - By construction –
    1. Drum type brake,
    2. Disc type brake

### Anti-lock braking system (ABS)



Anti-lock braking system (ABS) is an automobile safety system that allows the wheels on a motor vehicle to maintain tractive contact with the road surface according to driver inputs while braking, preventing the wheels from locking up (ceasing rotation) and avoiding uncontrolled skidding. It is an automated system that uses the principles of threshold braking and cadence braking which were practiced by skillful drivers with previous generation braking systems. It does this at a much faster



rate and with better control than a driver could manage.

ABS generally offers improved vehicle control and decreases stopping distances on dry and slippery surfaces for many drivers; however, on loose surfaces like gravel or snow-covered pavement, ABS can significantly increase braking distance, although still improving vehicle control.

Since initial widespread use in production cars, anti-lock braking systems have evolved considerably. Recent versions not only prevent wheel lock under braking, but also electronically control the front-to-rear brake bias. This function, depending on its specific capabilities and implementation, is known as electronic brake force distribution (EBD), traction control system, emergency brake assist, or electronic stability control(ESC).

## **Operation**

The anti-lock brake controller is also known as the CAB (Controller Anti-lock Brake). Typically ABS includes a central electronic control unit (ECU), four wheel speed sensors, and at least two hydraulic valves within the brake hydraulics. The ECU constantly monitors the rotational speed of each wheel; if it detects a wheel rotating significantly slower than the others, a condition indicative of impending wheel lock, it actuates the valves to reduce hydraulic pressure to the brake at the affected wheel, thus reducing the braking force on that wheel; the wheel then turns faster.

Conversely, if the ECU detects a wheel turning significantly faster than the others, brake hydraulic pressure to the wheel is increased so the braking force is reapplied, slowing down the wheel. This process is repeated continuously and can be detected by the driver via brake pedal pulsation. Some anti-lock systems can apply or release braking pressure 15 times per second.<sup>[17]</sup> Because of this, the wheels of cars equipped with ABS are practically impossible to lock even during panic braking in extreme conditions.

The ECU is programmed to disregard differences in wheel rotative speed below a critical threshold,



because when the car is turning, the two wheels towards the center of the curve turn slower than the outer two. For this same reason, a differential is used in virtually all roadgoing vehicles. If a fault develops in any part of the ABS, a warning light will usually be illuminated on the vehicle instrument panel, and the ABS will be disabled until the fault is rectified.

Modern ABS applies individual brake pressure to all four wheels through a control system of hub-mounted sensors and a dedicated micro-controller. ABS is offered or comes standard on most road vehicles produced today and is the foundation for electronic stability control systems, which are rapidly increasing in popularity due to the vast reduction in price of vehicle electronics over the years.

Modern electronic stability control systems are an evolution of the ABS concept. Here, a minimum of two additional sensors are added to help the system work: these are a steering wheel angle sensor, and a gyroscopic sensor. The theory of operation is simple: when the gyroscopic sensor detects that the direction taken by the car does not coincide with what the steering wheel sensor reports, the ESC software will brake the necessary individual wheel(s) (up to three with the most sophisticated systems), so that the vehicle goes the way the driver intends. The steering wheel sensor also helps in the operation of Cornering Brake Control (CBC), since this will tell the ABS that wheels on the inside of the curve should brake more than wheels on the outside, and by how much.

ABS equipment may also be used to implement a traction control system (TCS) on acceleration of the vehicle. If, when accelerating, the tire loses traction, the ABS controller can detect the situation and take suitable action so that traction is regained. More sophisticated versions of this can also control throttle levels and brakes simultaneously.

## **Components of ABS**

There are four main components of ABS:

- Speed sensors,
- Valves,



- Pump, and
- Controller.

## **Speed sensors**

A speed sensor is used to determine the acceleration or deceleration of the wheel. These sensors use a magnet and a coil of wire to generate a signal. The rotation of the wheel or differential induces a magnetic field around the sensor. The fluctuations of this magnetic field generate a voltage in the sensor. Since the voltage induced in the sensor is a result of the rotating wheel, this sensor can become inaccurate at slow speeds. The slower rotation of the wheel can cause inaccurate fluctuations in the magnetic field and thus cause inaccurate readings to the controller.

## **Valves**

There is a valve in the brake line of each brake controlled by the ABS. On some systems, the valve has three positions:

In position one, the valve is open; pressure from the master cylinder is passed right through to the brake.

In position two, the valve blocks the line, isolating that brake from the master cylinder. This prevents the pressure from rising further should the driver push the brake pedal harder.

In position three, the valve releases some of the pressure from the brake.

The majority of problems with the valve system occur due to clogged valves. When a valve is clogged it is unable to open, close, or change position. An inoperable valve will prevent the system from modulating the valves and controlling pressure supplied to the brakes.

## **Pump**



The pump in the ABS is used to restore the pressure to the hydraulic brakes after the valves have released it. A signal from the controller will release the valve at the detection of wheel slip. After a valve release the pressure supplied from the user, the pump is used to restore a desired amount of pressure to the braking system. The controller will modulate the pumps status in order to provide the desired amount of pressure and reduce slipping.

## **Controller**

The controller is an ECU type unit in the car which receives information from each individual wheel speed sensor, in turn if a wheel loses traction the signal is sent to the controller, the controller will then limit the brake force (EBD) and activate the ABS modulator which actuates the braking valves on and off.

## **Use**

There are many different variations and control algorithms for use in ABS. One of the simpler systems works as follows,

The controller monitors the speed sensors at all times. It is looking for decelerations in the wheel that are out of the ordinary. Right before wheel locks up, it will experience a rapid deceleration.

If left unchecked, the wheel would stop much more quickly than any car could. It might take a car five seconds to stop from 60 mph (96.6 km/h) under ideal conditions, but a wheel that locks up could stop spinning in less than a second.

The ABS controller knows that such a rapid deceleration is impossible, so it reduces the pressure to that brake until it sees an acceleration, then it increases the pressure until it sees the deceleration again. It can do this very quickly, before the tire can actually significantly change speed. The result is that the tire slows down at the same rate as the car, with the brakes keeping the tires very near the point at which they will start to lock up. This gives the system maximum braking power.

This replaces the need to manually pump the brakes while driving on a slippery or a low traction



surface, allowing steering even in the most emergency braking conditions.

When the ABS is in operation the driver will feel a pulsing in the brake pedal; this comes from the rapid opening and closing of the valves. This pulsing also tells the driver that the ABS has been triggered. Some ABS systems can cycle up to 16 times per second.

## **Hydraulic braking system**

The disc brake or disk brake is a device for slowing or stopping the rotation of a wheel while it is in motion. A brake disc (or rotor in U.S. English) is usually made of cast iron, but may in some cases be made of composites such as reinforced carbon-carbon or ceramic-matrix composites.

This is connected to the wheel and/or the axle. To stop the wheel, friction material in the form of brake pads (mounted on a device called a brake caliper) is forced mechanically, hydraulically, pneumatically or electromagnetically against both sides of the disc. Friction causes the disc and attached wheel to slow or stop. Brakes (both disc and drum) convert motion to heat, but if the brakes get too hot, they will become less effective because they cannot dissipate enough heat. This condition of failure is known as brake fade.

## **Construction of Braking system;**

The most common arrangement of hydraulic brakes for passenger vehicles, motorcycles, scooters, and mopeds, consists of the following:

- Brake pedal or lever
- A pushrod (also called an actuating rod)
- A master cylinder assembly containing a piston assembly
- Reinforced hydraulic lines

Brake caliper assembly usually consisting of one or two hollow aluminum or chrome-plated steel pistons (called caliper pistons), a set of thermally conductive brake pads and a rotor (also called a



brake disc) or drum attached to an axle. The system is usually filled with a glycol-ether based brake fluid (other fluids may also be used).

At one time, passenger vehicles commonly employed drum brakes on all four wheels. Later, disc brakes were used for the front and drum brakes for the rear. However disc brakes have shown better heat dissipation and greater resistance to 'fading' and are therefore generally safer than drum brakes. So four-wheel disc brakes have become increasingly popular, replacing drums on all but the most basic vehicles. Many two-wheel vehicle designs, however, continue to employ a drum brake for the rear wheel. The following description uses the terminology for and configuration of a simple

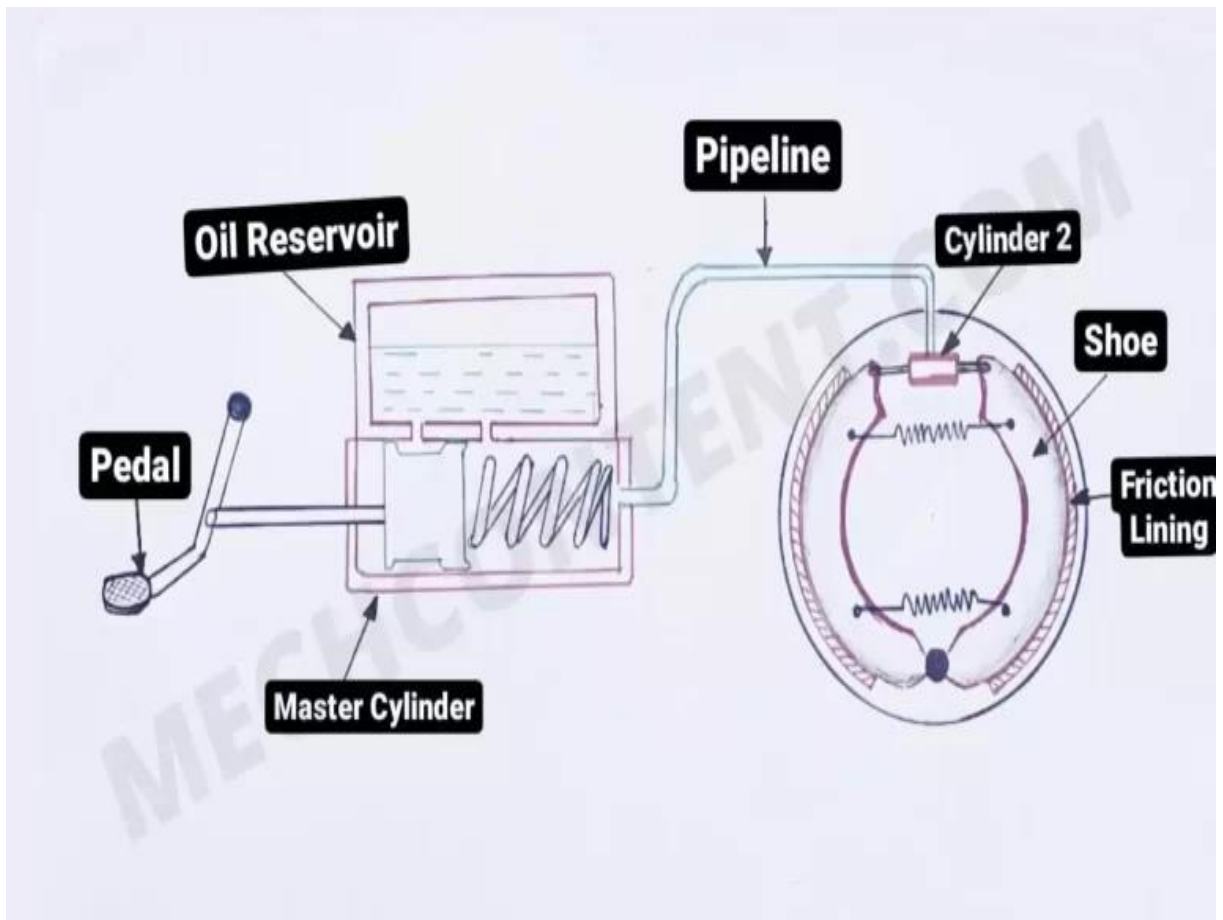
In a hydraulic brake system, when the brake pedal is pressed, a pushrod exerts force on the piston(s) in the master cylinder, causing fluid from the brake fluid reservoir to flow into a pressure chamber through a compensating port. This results in an increase in the pressure of the entire hydraulic system, forcing fluid through the hydraulic lines toward one or more calipers where it acts upon one or two caliper pistons sealed by one or more seated O-rings (which prevent leakage of the fluid).

The brake caliper pistons then apply force to the brake pads, pushing them against the spinning rotor, and the friction between the pads and the rotor causes a braking torque to be generated, slowing the vehicle. Heat generated by this friction is either dissipated through vents and channels in the rotor or is conducted through the pads, which are made of specialized heat-tolerant materials such as kevlar or sintered glass.

Subsequent release of the brake pedal/lever allows the spring(s) in my master cylinder assembly to return the master piston(s) back into position. This action first relieves the hydraulic pressure on the caliper, then applies suction to the brake piston in the caliper assembly, moving it back into its housing and allowing the brake pads to release the rotor.

The hydraulic braking system is designed as a closed system: unless there is a leak in the system, none of the brake fluid enters or leaves it, nor does the fluid get consumed through use.





## Pneumatic braking system

An air brake or, more formally, a compressed air brake system, is a type of friction brake for vehicles in which compressed air pressing on a piston is used to apply the pressure to the brake pad needed to stop the vehicle.

Air brakes are used in large heavy vehicles, particularly those having multiple trailers which must be linked into the brake system, such as trucks, buses, trailers, and semi-trailers in addition to their use in railroad trains.

George Westinghouse first developed air brakes for use in railway service. He patented a safer air brake on March 5, 1872. Westinghouse made numerous alterations to improve his air pressured brake invention, which led to various forms of the automatic brake. In the early 20th century, after its advantages were proven in railway use, it was adopted by manufacturers of trucks and heavy road vehicles



## **Construction of Braking system;**

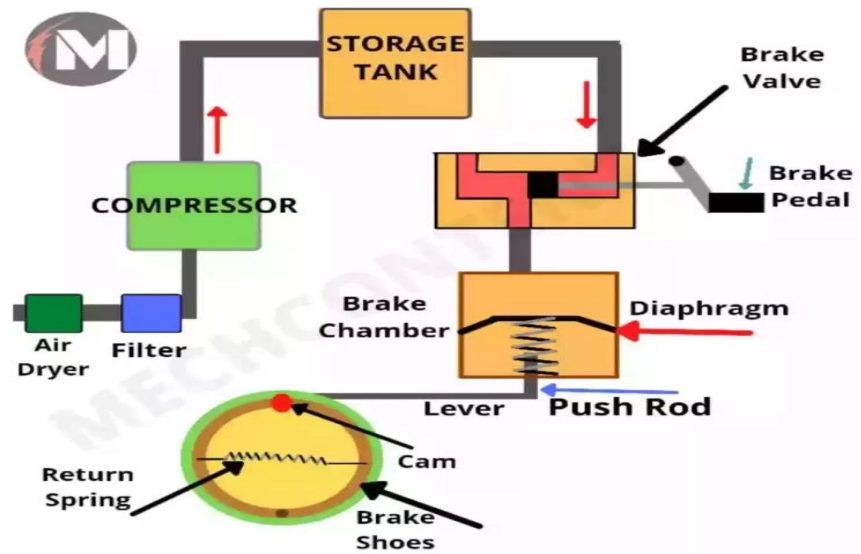
Air brake systems are typically used on heavy trucks and buses. The system consists of service brakes, parking brakes, a control pedal, and an air storage tank. For the parking brake, there is a disc or drum brake arrangement which is designed to be held in the 'applied' position by spring pressure.

Air pressure must be produced to release these "spring brake" parking brakes. For the service brakes (the ones used while driving for slowing or stopping) to be applied, the brake pedal is pushed, routing the air under pressure (approx 100–120 psi or 690–830 kPa) to the brake chamber, causing the brake to be engaged. Most types of truck air brakes are drum brakes, though there is an increasing trend towards the use of disc brakes in this application. The air compressor draws filtered air from the atmosphere and forces it into high-pressure reservoirs at around 120 psi (830 kPa).

Most heavy vehicles have a gauge within the driver's view, indicating the availability of air pressure for safe vehicle operation, often including warning tones or lights. Setting of the parking/emergency brake releases the pressurized air in the lines between the compressed air storage tank and the brakes, thus allowing the spring actuated parking brake to engage. A sudden loss of air pressure would result in full spring brake pressure immediately.

A compressed air brake system is divided into a supply system and a control system. The supply system compresses, stores and supplies high-pressure air to the control system as well as to additional air operated auxiliary truck systems (gearbox shift control, clutch pedal air assistance servo, etc.).





Highly simplified air brake diagram on a commercial road vehicle (does not show all air reservoirs and all applicable air valves). The air compressor is driven by the engine either by crankshaft pulley via a belt or directly from the engine timing gears. It is lubricated and cooled by the engine lubrication and cooling systems.

Compressed air is first routed through a cooling coil and into an air dryer which removes moisture and oil impurities and also may include a pressure regulator, safety valve and smaller purge reservoir. As an alternative to the air dryer, the supply system can be equipped with an anti-freeze device and oil separator. The compressed air is then stored in a reservoir (also called a wet tank) from which it is then distributed via a four way protection valve into the front and rear brake circuit air reservoir, a parking brake reservoir and an auxiliary air supply distribution point. The system also includes various check, pressure limiting, drain and safety valves. Air brake systems may include a wig wag device which deploys to warn the driver if the system air pressure drops too low.

## Control system

The control system is further divided into two service brake circuits: the parking brake circuit and the trailer brake circuit. This dual brake circuit is further split into front and rear wheel circuits which receive compressed air from their individual reservoirs for added safety in case of an air leak. The



service brakes are applied by means of a brake pedal air valve which regulates both circuits.

The parking brake is the air operated spring brake type where its applied by spring force in the spring brake cylinder and released by compressed air via hand control valve. The trailer brake consists of a direct two line system: the supply line (marked red) and the separate control or service line (marked blue). The supply line receives air from the prime mover park brake air tank via a park brake relay valve and the control line is regulated via the trailer brake relay valve. The operating signals for the relay are provided by the prime mover brake pedal air valve, trailer service brake hand control (subject to a country's relevant heavy vehicle legislation) and the prime mover park brake hand control.

### **Advantages of Air Brakes;**

Air brakes are used as an alternative to hydraulic brakes which are used on lighter vehicles such as automobiles. Hydraulic brakes use a liquid (hydraulic fluid) to transfer pressure from the brake pedal to the brake shoe to stop the vehicle. Air brakes have several advantages for large multitrailer vehicles:

- The supply of air is unlimited, so the brake system can never run out of its operating fluid, as hydraulic brakes can. Minor leaks do not result in brake failures.
- Air line couplings are easier to attach and detach than hydraulic lines; there is no danger of letting air into hydraulic fluid. So air brake circuits of trailers can be attached and removed easily by operators with little training.
- Air not only serves as a fluid for transmission of force, but also stores potential energy. So it can serve to control the force applied. Air brake systems include an air tank that stores sufficient energy to stop the vehicle if the compressor fails.
- Air brakes are effective even with considerable leakage, so an air brake system can be designed with sufficient "fail-safe" capacity to stop the vehicle safely even when leaking.





---

## UNIT V

# ALTERNATIVE ENERGY SOURCES

---

---



## UNIT V

### ALTERNATIVE ENERGY SOURCES

#### 5.1. Natural Gas as a Fuel in Automobile;

A natural gas vehicle (NGV) is an alternative fuel vehicle that uses compressed natural gas (CNG) or liquefied natural gas (LNG) as a cleaner alternative to other fossil fuels. Natural gas vehicles should not be confused with vehicles powered by propane (LPG), which is a fuel with a fundamentally different composition. Worldwide, there were 14.8 million natural gas vehicles by 2011, led by Iran with 2.86 million, Pakistan (2.85 million), Argentina (2.07 million), Brazil (1.70 million), and India (1.10 million).

The Asia-Pacific region leads the world with 6.8 million NGVs, followed by Latin America with 4.2 million vehicles. In the Latin American region almost 90% of NGVs have bi-fuel engines, allowing these vehicles to run on either gasoline or CNG. In Pakistan, almost every vehicle converted to (or manufactured for) alternative fuel use typically retains the capability to run on ordinary gasoline.

As of 2009, the U.S. had a fleet of 114,270 compressed natural gas (CNG) vehicles, mostly buses; 147,030 vehicles running on liquefied petroleum gas (LPG); and 3,176 vehicles liquefied natural gas (LNG). Other countries where natural gas-powered buses are popular include India, Australia, Argentina, and Germany. In OECD countries there are around 500,000 CNG vehicles. Pakistan's market share of NGVs was 61.1% in 2010, followed by Armenia with 32%, and Bolivia with 20%. The number of NGV refueling stations has also increased, to 18,202 worldwide as of 2010, up 10.2% from the previous year.

Existing gasoline-powered vehicles may be converted to run on CNG or LNG, and can be dedicated (running only on natural gas) or bi-fuel (running on either gasoline or natural gas). Diesel engines for heavy trucks and busses can also be converted and can be dedicated with the addition of new heads containing spark ignition systems, or can be run on a blend of diesel and natural gas, with the primary fuel being natural gas and a small amount of diesel fuel being used



as an ignition source.

An increasing number of vehicles worldwide are being manufactured to run on CNG. Until recently, the Honda Civic GX was the only NGV commercially available in the US market., however now Ford, GM and Ram have bi-fuel offerings in their vehicle lineup. Fords approach is to offer a bi-fuel prep kit as a factory option, and then have the customer choose an authorized partner to install the natural gas equipment.

In 2006 the Brazilian subsidiary of FIAT introduced the Fiat Siena Tetra fuel, a four-fuel car developed under Magneti Marelli of Fiat Brazil. This automobile can run on natural gas (CNG); 100% ethanol (E100); E20 to E25 gasoline blend, Brazil's mandatory gasoline; and pure gasoline, though no longer available in Brazil it is used in neighboring countries.

NGV filling stations can be located anywhere that natural gas lines exist. Compressors (CNG) or liquification plants (LNG) are usually built on large scale but with CNG small home refueling stations are possible. A company called FuelMaker pioneered such a system called Phill Home Refueling Appliance (known as "Phill"), which they developed in partnership with Honda for the American GX model. Phill is now manufactured and sold by BRC FuelMaker, a division of Fuel Systems Solutions, Inc.

CNG may also be mixed with biogas, produced from landfills or wastewater, which doesn't increase the concentration of carbon in the atmosphere. Despite its advantages, the use of natural gas vehicles faces several limitations, including fuel storage and infrastructure available for delivery and distribution at fueling stations. CNG must be stored in high pressure cylinders (3000psi to 3600psi operation pressure), and LNG must be stored in cryogenic cylinders (-260F to -200F).

These cylinders take up more space than gasoline or diesel tanks that can be molded in intricate shapes to store more fuel and use less on-vehicle space. CNG tanks are usually located in the vehicle's trunk or pickup bed, reducing the space available for other cargo. This problem can be solved by installing the tanks under the body of the vehicle, or on the roof (typical for busses), leaving cargo areas free.



As with other alternative fuels, other barriers for widespread use of NGVs are natural gas distribution to and at fueling stations as well as the low number of CNG and LNG stations. CNG- powered vehicles are considered to be safer than gasoline-powered vehicles

## **5.2.Liquefied petroleum gas as a Fuel in Automobile;**

Liquefied petroleum gas or liquid petroleum gas (LPG or LP gas), also referred to as simply propane or butane, is a flammable mixture of hydrocarbon gases used as a fuel in heating appliances, cooking equipment, and vehicles. It is increasingly used as an aerosol propellant and a refrigerant, replacing chlorofluorocarbons in an effort to reduce damage to the ozone layer. When specifically used as a vehicle fuel it is often referred to as auto gas.

Varieties of LPG bought and sold include mixes that are primarily propane ( $C_3H_8$ ), primarily butane ( $C_4H_{10}$ ) and, most commonly, mixes including both propane and butane. In winter, the mixes contain more propane, while in summer, they contain more butane. In the United States, primarily two grades of LPG are sold: commercial propane and HD-5. These specifications are published by the Gas Processors Association (GPA) and the American Society of Testing and Materials (ASTM). Propane/butane blends are also listed in these specifications.

Propylene, butylenes and various other hydrocarbons are usually also present in small concentrations. HD-5 limits the amount of propylene that can be placed in LPG to 5%, and is utilized as an autogas specification. A powerful odorant, ethanethiol, is added so that leaks can be detected easily. The international standard is EN 589. In the United States, tetrahydrothiophene (thiophane) or amyl mercaptan are also approved odorants,[5] although neither is currently being utilized.

LPG is prepared by refining petroleum or "wet" natural gas, and is almost entirely derived from fossil fuel sources, being manufactured during the refining of petroleum (crude oil), or extracted from petroleum or natural gas streams as they emerge from the ground. It was first produced in 1910 by Dr. Walter Snelling, and the first commercial products appeared in 1912. It currently provides about 3% of all energy consumed, and burns relatively cleanly with no soot and very few sulfur emissions.



As it is a gas, it does not pose ground or water pollution hazards, but it can cause air pollution. LPG has a typical specific calorific value of 46.1 MJ/kg compared with 42.5 MJ/kg for fuel oil and 43.5 MJ/kg for premium grade petrol (gasoline).[6] However, its energy density per volume unit of 26 MJ/L is lower than either that of petrol or fuel oil, as its relative density is lower (about 0.5–0.58, compared to 0.71–0.77 for gasoline).

As its boiling point is below room temperature, LPG will evaporate quickly at normal temperatures and pressures and is usually supplied in pressurised steel vessels. They are typically filled to 80–85% of their capacity to allow for thermal expansion of the contained liquid. The ratio between the volumes of the vaporized gas and the liquefied gas varies depending on composition, pressure, and temperature, but is typically around 250:1.

The pressure at which LPG becomes liquid, called its vapour pressure, likewise varies depending on composition and temperature; for example, it is approximately 220 kilopascals (32 psi) for pure butane at 20 °C (68 °F), and approximately 2,200 kilopascals (320 psi) for pure propane at 55 °C (131 °F). LPG is heavier than air, unlike natural gas, and thus will flow along floors and tend to settle in low spots, such as basements. There are two main dangers from this. The first is a possible explosion if the mixture of LPG and air is within the explosive limits and there is an ignition source. The second is suffocation due to LPG displacing air, causing a decrease in oxygen concentration.

Large amounts of LPG can be stored in bulk cylinders and can be buried underground.

### **Bio diesel as a Fuel in Automobile;**

Biodiesel and conventional diesel vehicles are one in the same. Although light-, medium-, and heavy-duty diesel vehicles are not technically "alternative fuel" vehicles, many are capable of running on biodiesel. Biodiesel, which is most often used as a blend with regular diesel fuel, can be used in many diesel vehicles without any engine modification. The most common biodiesel blend is B20, which is 20% biodiesel and 80% conventional diesel. B5 (5% biodiesel, 95% diesel) is also commonly used in fleets.

Before using biodiesel, be sure to check your engine warranty to ensure that higher-level blends



(all OEMs accept the use of B5 and many accept the use of B20) of this alternative fuel don't void or affect it. High-level biodiesel blends (blends over B20) can have a solvency effect in engines and fuel systems that previously used petroleum diesel which may result in degraded seals and clogged fuel filters.

Biodiesel improves fuel lubricity and raises the cetane number of the fuel. Diesel engines depend on the lubricity of the fuel to keep moving parts from wearing prematurely. Federal regulations have gradually reduced allowable fuel sulfur to only 15 parts per million, which has often resulted in lowered aromatics content in diesel fuel. One advantage of biodiesel is that it can impart adequate lubricity to diesel fuels at blend levels as low as 1%.

### **Hybrid electric vehicle:**

A hybrid electric vehicle (HEV) is a type of hybrid vehicle and electric vehicle which combines a conventional internal combustion engine (ICE) propulsion system with an electric propulsion system. The presence of the electric powertrain is intended to achieve either better fuel economy than a conventional vehicle or better performance. There are a variety of HEV types, and the degree to which they function as EVs varies as well. The most common form of HEV is the hybrid electric car, although hybrid electric trucks (pickups and tractors) and buses also exist.

Modern HEVs make use of efficiency-improving technologies such as regenerative braking, which converts the vehicle's kinetic energy into electric energy to charge the battery, rather than wasting it as heat energy as conventional brakes do. Some varieties of HEVs use their internal combustion engine to generate electricity by spinning an electrical generator (this combination is known as a motor-generator), to either recharge their batteries or to directly power the electric drive motors

Many HEVs reduce idle emissions by shutting down the ICE at idle and restarting it when needed; this is known as a start-stop system. A hybrid-electric produces less emissions from its ICE than a comparably sized gasoline car, since an HEV's gasoline engine is usually smaller than a comparably sized pure gasoline-burning vehicle (natural gas and propane fuels produce



lower emissions) and if not used to directly drive the car, can be geared to run at maximum



efficiency, further improving fuel economy.

In 1901 Ferdinand Porsche developed the Lohner-Porsche Mixte Hybrid, the first gasoline- electric hybrid automobile in the world. The hybrid-electric vehicle did not become widely available until the release of the Toyota Prius in Japan in 1997, followed by the Honda Insight in 1999. While initially perceived as unnecessary due to the low cost of gasoline, worldwide increases in the price of petroleum caused many automakers to release hybrids in the late 2000s; they are now perceived as a core segment of the automotive market of the future.

About 9 million hybrid electric vehicles have been sold worldwide by October 2014, led by Toyota Motor Company (TMC) with more than 7 million Lexus and Toyota hybrids sold as of September 2014, followed by Honda Motor Co., Ltd. with cumulative global sales of more than

1.35 million hybrids as of June 2014, Ford Motor Corporation with over 375 thousand hybrids sold in the United States through September 2014, and the Hyundai Group with cumulative global sales of 200 thousand hybrids as of March 2014, including both Hyundai Motors and Kia Motors hybrid models.

Worldwide sales of hybrid vehicles produced by TMC reached 1 million units in May 2007; 2 million in August 2009; and passed the 5 million mark in March 2013. As of December 2013, worldwide hybrid sales are led by the Toyota Prius lift back, with cumulative sales of 3.17 million units, and available in almost 80 countries and regions.

The Prius nameplate has sold 4.2 million hybrids and plug-in hybrids up to December 2013. The United States is the world's largest hybrid market with over 3 million hybrid automobiles and SUVs sold through October 2013, followed by Japan with more than 2.6 million hybrids sold through September 2013. The Prius is the top selling hybrid car in the U.S. market, passing the 1 million milestones in April 2011. Cumulative sales of the Prius in Japan reached the 1 million mark in August 2011.

### **Fuel Cell:**

A Fuel Cell is an electrochemical device that combines hydrogen and oxygen to produce



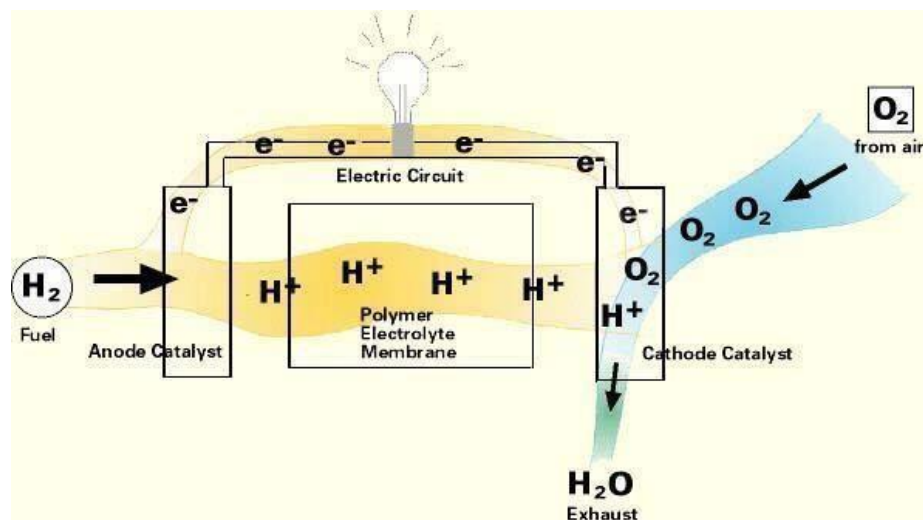
electricity, with water and heat as its by-product. Since conversion of the fuel to energy takes



place via an electrochemical process, not combustion. It is a clean, quiet and highly efficient process- two to three times more efficient than fuel burning.

It operates similarly to a battery, but it does not run down nor does it require recharging As long as fuel is supplied, a Fuel Cell will produce both energy and heat A Fuel Cell consists of two catalyst coated electrodes surrounding an electrolyte. One electrode is an anode and the other is a cathode The process begins when Hydrogen molecules enter the anode The catalyst coating separates hydrogen's negatively charged electrons from the positively charged protons The electrolyte allows the protons to pass through to the cathode, but not the electrons. The

electrolyte allows the protons to pass through to the cathode, but not the electrons. Instead the electrons are directed through an external circuit which creates electrical current. While the electrons pass through the external circuit, oxygen molecules pass through the cathode. There the oxygen and the protons combine with the electrons after they have passed through the external circuit. When the oxygen and the protons combine with the electrons it produces water and heat. Individual fuel cells can then be placed in a series to form a fuel cell stack. The stack can be used in a system to power a vehicle or to provide stationary power to a building



## **Hydrogen:**

- ❑ Hydrogen is the most abundant element in the universe, but it does not exist by itself in nature.
- ❑ Instead, it is found bonded to other elements in compounds such as water, natural gas, coal, or biological material.
- ❑ Hydrogen can be produced from a number of different sources, including natural gas, water, methanol etc. Two methods are generally used to produce hydrogen:
  - (1) Electrolysis
  - (2) Synthesis gas production from steam reforming or partial oxidation.
- ❑ Hydrogen and oxygen from air fed into a proton exchange membrane fuel cell produce enough electricity to power an electric automobile, without producing harmful emissions. The only byproduct of a hydrogen fuel cell is water.
- ❑ When burned in an internal combustion engine, small amounts of nitrogen oxides and small amounts of unburned hydrocarbons and carbon monoxide are produced, due to the use of engine lubricants.

### **Advantages**

- Hydrogen is the perfect fuel to run fuel cells cause pure hydrogen reacts only with oxygen releasing water thus no emissions.
- Hydrogen burns more efficiently and creates energy more efficiently than gasoline.
- Hydrogen has high self-ignition temperature but requires very little energy to ignite it.
- As a fuel it is very efficient as there are no losses associated with throttling.

## **AE QUESTION BANK**

### **UNIT-I**

1. Explain how a four wheel drive mechanism offers better power transmission in a Automobile.
2. Explain how the power can be transmitted in front wheel drive by using a neat diagram.
3. Explain with neat sketches the various types of chassis & discuss their advantages and disadvantages
4. Briefly discuss the working principle of a simple Carburetor system with neat sketch

### **UNIT-II**

1. What are catalytic convertors and explain how they help in containing emissions from a automobile.
2. Explain briefly the methods available to control emissions from a automobile.
3. Write about thermal and catalytic converters?
4. Explain common rail diesel injection system with necessary diagram.

### **UNIT-III**

1. Explain with a simple sketch, working of differential in a automobile
2. Explain the construction working and performance of a fluid flywheel. Enumerate the advantages of fluid flywheel over the other types of clutches
3. Draw and explain with a simple sketch, working of a constant mesh gear box.
4. Draw a schematic diagram and explain the working of a torque convertor.
5. Explain with a simple sketch, construction and working of differential in a automobile
6. Explain with a simple sketch, construction and working of epicyclic gear box in a automobile.

### **UNIT-IV**

1. Define camber, castor, king pin rake angles and their significance in steering geometry.
2. With the help of a schematic diagram, explain Ackerman steering mechanism.
3. Explain the functioning of independent front wheel suspension system with torsion bar in a automobile.
4. Explain with a suitable schematic diagram, working of hydraulic braking system in a vehicle.
5. What is ABS and how does ABS helps in improving uncontrolled skidding?

6. Explain the functioning of rigid axle suspension system with a neat sketch.
7. Briefly discuss the functional requirements of braking fluids.

#### **UNIT-V**

1. Explain the electric and hybrid vehicle with neat sketch?
2. Explain different fuel cells with a neat sketch .Give their advantages and disadvantages?
3. Explain the operation of liquefied petroleum gas system with a neat sketch?
4. Explain engine modification required to use the alternate fuel in automobiles?