

# COURSE MATERIAL

III Year B. Tech I- Semester  
MECHANICAL ENGINEERING  
AY: 2023-24



Thermal Engineering

R20A0314



Prepared by:  
Dr. Hussain Valli Assoc. Professor



**MALLA REDDY COLLEGE OF ENGINEERING & TECHNOLOGY**  
**DEPARTMENT OF MECHANICAL ENGINEERING**

(Autonomous Institution-UGC, Govt. of India)  
Secunderabad-500100, Telangana State, India.  
[www.mrcet.ac.in](http://www.mrcet.ac.in)



# MALLA REDDY COLLEGE OF ENGINEERING & TECHNOLOGY

(Autonomous Institution – UGC, Govt. of India)

## DEPARTMENT OF MECHANICAL ENGINEERING

---

### CONTENTS

1. Vision, Mission & Quality Policy
2. Pos, PSOs & PEOs
3. Blooms Taxonomy
4. Course Syllabus
5. Lecture Notes (Unit wise)
  - a. Objectives and outcomes
  - b. Notes
  - c. Presentation Material (PPT Slides/ Videos)
  - d. Industry applications relevant to the concepts covered
  - e. Question Bank for Assignments
  - f. Tutorial Questions
6. Previous Question Papers



# MALLA REDDY COLLEGE OF ENGINEERING & TECHNOLOGY

(Autonomous Institution – UGC, Govt. of India)

---

## VISION

- ❖ To establish a pedestal for the integral innovation, team spirit, originality and competence in the students, expose them to face the global challenges and become technology leaders of Indian vision of modern society.

## MISSION

- ❖ To become a model institution in the fields of Engineering, Technology and Management.
- ❖ To impart holistic education to the students to render them as industry ready engineers.
- ❖ To ensure synchronization of MRCET ideologies with challenging demands of International Pioneering Organizations.

## QUALITY POLICY

- ❖ To implement best practices in Teaching and Learning process for both UG and PG courses meticulously.
- ❖ To provide state of art infrastructure and expertise to impart quality education.
- ❖ To groom the students to become intellectually creative and professionally competitive.
- ❖ To channelize the activities and tune them in heights of commitment and sincerity, the requisites to claim the never - ending ladder of **SUCCESS** year after year.

For more information: [www.mrcet.ac.in](http://www.mrcet.ac.in)

# **MALLA REDDY COLLEGE OF ENGINEERING & TECHNOLOGY**

(Autonomous Institution – UGC, Govt. of India)

[www.mrcet.ac.in](http://www.mrcet.ac.in)

**Department of Mechanical Engineering**

---

## **VISION**

To become an innovative knowledge center in mechanical engineering through state-of-the-art teaching-learning and research practices, promoting creative thinking professionals.

## **MISSION**

The Department of Mechanical Engineering is dedicated for transforming the students into highly competent Mechanical engineers to meet the needs of the industry, in a changing and challenging technical environment, by strongly focusing in the fundamentals of engineering sciences for achieving excellent results in their professional pursuits.

## **Quality Policy**

To pursuit global Standards of excellence in all our endeavors namely teaching, research and continuing education and to remain accountable in our core and support functions, through processes of self-evaluation and continuous improvement.

To create a midst of excellence for imparting state of art education, industry-oriented training research in the field of technical education.

# MALLA REDDY COLLEGE OF ENGINEERING & TECHNOLOGY

(Autonomous Institution – UGC, Govt. of India)

www.mrcet.ac.in

Department of Mechanical Engineering

---

## PROGRAM OUTCOMES

Engineering Graduates will be able to:

- 1. Engineering knowledge:** Apply the knowledge of mathematics, science, engineering fundamentals, and an engineering specialization to the solution of complex engineering problems.
- 2. Problem analysis:** Identify, formulate, review research literature, and analyze complex engineering problems reaching substantiated conclusions using first principles of mathematics, natural sciences, and engineering sciences.
- 3. Design/development of solutions:** Design solutions for complex engineering problems and design system components or processes that meet the specified needs with appropriate consideration for the public health and safety, and the cultural, societal, and environmental considerations.
- 4. Conduct investigations of complex problems:** Use research-based knowledge and research methods including design of experiments, analysis and interpretation of data, and synthesis of the information to provide valid conclusions.
- 5. Modern tool usage:** Create, select, and apply appropriate techniques, resources, and modern engineering and IT tools including prediction and modeling to complex engineering activities with an understanding of the limitations.
- 6. The engineer and society:** Apply reasoning informed by the contextual knowledge to assess societal, health, safety, legal and cultural issues and the consequent responsibilities relevant to the professional engineering practice.
- 7. Environment and sustainability:** Understand the impact of the professional engineering solutions in societal and environmental contexts, and demonstrate the knowledge of, and need for sustainable development.
- 8. Ethics:** Apply ethical principles and commit to professional ethics and responsibilities and norms of the engineering practice.
- 9. Individual and teamwork:** Function effectively as an individual, and as a member or leader in diverse teams, and in multidisciplinary settings.
- 10. Communication:** Communicate effectively on complex engineering activities with the engineering community and with society at large, such as, being able to comprehend and write effective reports and design documentation, make effective presentations, and give and receive clear instructions.
- 11. Project management and finance:** Demonstrate knowledge and understanding of the engineering and management principles and apply these to one's own work, as a member and leader in a team, to manage projects and in multidisciplinary environments.

# MALLA REDDY COLLEGE OF ENGINEERING & TECHNOLOGY

(Autonomous Institution – UGC, Govt. of India)

www.mrcet.ac.in

## Department of Mechanical Engineering

---

**12. Life-long learning:** Recognize the need for and have the preparation and ability to engage in independent and life-long learning in the broadest context of technological change.

### PROGRAM SPECIFIC OUTCOMES (PSOs)

- PSO1** Ability to analyze, design and develop Mechanical systems to solve the Engineering problems by integrating thermal, design and manufacturing Domains.
- PSO2** Ability to succeed in competitive examinations or to pursue higher studies or research.
- PSO3** Ability to apply the learned Mechanical Engineering knowledge for the Development of society and self.

### Program Educational Objectives (PEOs)

The Program Educational Objectives of the program offered by the department are broadly listed below:

#### PEO1: PREPARATION

To provide sound foundation in mathematical, scientific and engineering fundamentals necessary to analyze, formulate and solve engineering problems.

#### PEO2: CORE COMPETANCE

To provide thorough knowledge in Mechanical Engineering subjects including theoretical knowledge and practical training for preparing physical models pertaining to Thermodynamics, Hydraulics, Heat and Mass Transfer, Dynamics of Machinery, Jet Propulsion, Automobile Engineering, Element Analysis, Production Technology, Mechatronics etc.

#### PEO3: INVENTION, INNOVATION AND CREATIVITY

To make the students to design, experiment, analyze, interpret in the core field with the help of other inter disciplinary concepts wherever applicable.

#### PEO4: CAREER DEVELOPMENT

To inculcate the habit of lifelong learning for career development through successful completion of advanced degrees, professional development courses, industrial training etc.

# **MALLA REDDY COLLEGE OF ENGINEERING & TECHNOLOGY**

(Autonomous Institution – UGC, Govt. of India)

[www.mrcet.ac.in](http://www.mrcet.ac.in)

**Department of Mechanical Engineering**

---

## **PEO5: PROFESSIONALISM**

To impart technical knowledge, ethical values for professional development of the student to solve complex problems and to work in multi-disciplinary ambience, whose solutions lead to significant societal benefits.

# MALLA REDDY COLLEGE OF ENGINEERING & TECHNOLOGY

(Autonomous Institution – UGC, Govt. of India)

[www.mrcet.ac.in](http://www.mrcet.ac.in)

Department of Mechanical Engineering

---

## Blooms Taxonomy

Bloom's Taxonomy is a classification of the different objectives and skills that educators set for their students (learning objectives). The terminology has been updated to include the following six levels of learning. These 6 levels can be used to structure the learning objectives, lessons, and assessments of a course.

1. **Remembering**: Retrieving, recognizing, and recalling relevant knowledge from long-term memory.
2. **Understanding**: Constructing meaning from oral, written, and graphic messages through interpreting, exemplifying, classifying, summarizing, inferring, comparing, and explaining.
3. **Applying**: Carrying out or using a procedure for executing or implementing.
4. **Analyzing**: Breaking material into constituent parts, determining how the parts relate to one another and to an overall structure or purpose through differentiating, organizing, and attributing.
5. **Evaluating**: Making judgments based on criteria and standard through checking and critiquing.
6. **Creating**: Putting elements together to form a coherent or functional whole; reorganizing elements into a new pattern or structure through generating, planning, or producing.

# MALLA REDDY COLLEGE OF ENGINEERING & TECHNOLOGY

(Autonomous Institution – UGC, Govt. of India)

[www.mrcet.ac.in](http://www.mrcet.ac.in)

Department of Mechanical Engineering

---

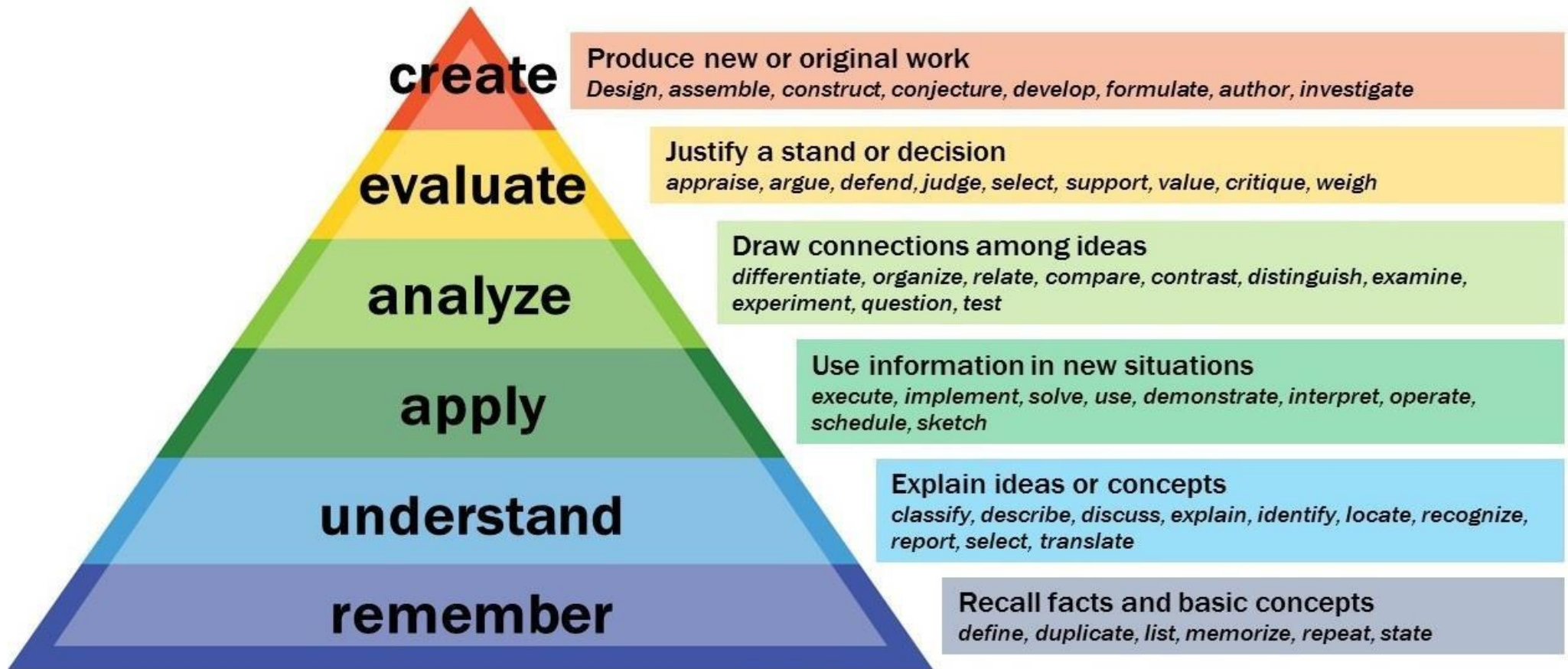

---

**MALLA REDDY COLLEGE OF ENGINEERING AND TECHNOLOGY**  
**III Year B.Tech. ME- I Sem**

**L/T/P/C**  
**3/-/-/3**

**(R20A0314) THERMAL ENGINEERING**

**COURSE OBJECTIVES:**

1. Student will learn applications and the principles of thermodynamics to components and systems.
2. Student will understand the thermodynamic principles which govern the behavior of various Engines.
3. Student have knowledge of methods of analysis and design of complicated thermodynamic systems
4. Student will acquire knowledge about thermodynamic analysis for compressors.
5. Student will obtain knowledge on various types of compressors and its functions.

**UNIT-I**

**Actual Cycles and their Analysis:** Introduction, Comparison of Air Standard and Actual Cycles, Time Loss Factor, Heat Loss Factor, Exhaust Blow down-Loss due to Gas exchange process, Volumetric Efficiency. Loss due to Rubbing Friction, Actual and Fuel-Air Cycles of CI Engines.

**I.C. ENGINES:** Classification - Working principles, Valve and Port Timing Diagrams, Air – Standard, air-fuel and actual cycles - Engine systems – Fuel, Carburetor, Fuel Injection System, Ignition, Cooling and Lubrication.

**UNIT-II**

**Combustion in S.I. Engines:** Normal Combustion and abnormal combustion – Importance of flame speed and effect of engine variables – Type of Abnormal combustion, pre-ignition and knocking (explanation of) – Fuel requirements and fuel rating, anti-knock additives – combustion chamber – requirements, types.

**Combustion in C.I. Engines:** Four stages of combustion – Delay period and its importance – Effect of engine variables – Diesel Knock– Need for air movement, suction, compression and combustion induced turbulence – open and divided combustion chambers and nozzles used – fuel requirements and fuel rating.

**UNIT-III**

**Testing and Performance of IC Engines:** Parameters of performance - measurement of cylinder pressure, fuel consumption, air intake, exhaust gas composition, Brake power – Determination of frictional losses and indicated power – Performance test – Heat balance sheet and chart.

**UNIT-IV**

**Compressors** – Classification –positive displacement and roto dynamic machinery – Power producing and power absorbing machines, fan, blower and compressor – positive displacement and dynamic types – reciprocating and rotary types.

**Reciprocating:** Principle of operation, work required, Isothermal efficiency volumetric efficiency and effect of clearance, stage compression, under cooling, saving of work, minimum work condition for stage compression.

**Rotary (Positive displacement type):** Roots Blower, vane sealed compressor, Lysholm compressor – mechanical details and principle of working – efficiency considerations.

**UNIT-V**

**Dynamic Compressors:** Centrifugal compressors: Mechanical details and principle of operation – velocity and pressure variation. Energy transfer-impeller blade shape-losses, slip factor, power input factor, pressure coefficient and adiabatic coefficient – velocity diagrams – power.

**Axial Flow Compressors:** Mechanical details and principle of operation – velocity triangles and energy transfer per stage degree of reaction, work done factor - isentropic efficiency- pressure rise calculations – Polytropic efficiency.

**TEXT BOOKS:**

1. I.C. Engines / V. GANESAN- TMH
2. Thermal Engineering / Rajput / Lakshmi Publications.
3. IC Engines – Mathur & Sharma – Dhanpath Rai & Sons.

**REFERENCE BOOKS:**

1. Thermal Engineering / Rudramoorthy - TMH
2. Thermodynamics & Heat Engines / R.S. Yadav/ Central Book Depot., Allahabad
3. Thermal Engineering – R.S. Khurmi & J.K.Gupta – S.Chand

**COURSE OUTCOMES:**

1. Graduate will recognize and recall the importance of thermodynamic analysis for improvement of efficiency.
2. Graduate will understand the working principles of SI and CI Engines.
3. Student will be able to do thermodynamic analysis for various powers and efficiencies of IC Engines.
4. Student will evaluate the thermodynamic analysis and various efficiencies of Compressors.

Student will develop the skill required in solving problems related to Compressors and do the thermodynamic analysis.

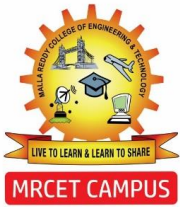

# MALLA REDDY COLLEGE OF ENGINEERING & TECHNOLOGY

(Autonomous Institution – UGC, Govt. of India)  
DEPARTMENT OF MECHANICAL ENGINEERING

## INTERNAL COMBUSTION ENGINES (R18A0313)

### COURSE OBJECTIVES

|          |  |
|----------|--|
| UNIT - 1 | <b>CO1:</b> To recall air standard cycles and compare with actual cycles, classification and working principles of air standard and actual cycles. |
| UNIT - 2 | <b>CO2:</b> Understand the process of combustion of IC engines and deal with practical challenges in combustion process.                           |
| UNIT - 3 | <b>CO3:</b> Evaluate the performance parameters of IC engines by conducting the performance tests.   |
| UNIT - 4 | <b>CO4:</b> Understand the classification of air compressors of positive displacement and rotodynamic.   |
| UNIT - 5 | <b>CO5:</b> Evaluate and analyze the performance of centrifugal and axial flow compressors.  |

# Bloom's Taxonomy - Cognitive

## 1 Remember

**Behavior:** To recall, recognize, or identify concepts

## 2 Understand

**Behavior:** To comprehend meaning, explain data in own words

## 3 Apply

**Behavior:** Use or apply knowledge, in practice or real life situations



## 4 Analyze

**Behavior:** Interpret elements, structure relationships between individual components

## 5 Evaluate

**Behavior:** Assess effectiveness of whole concepts in relation to other variables

## 6 Create

**Behavior:** Display creative thinking, develop new concepts or approaches

# COURSE OUTLINE

## UNIT – 1

NO OF LECTURE HOURS: 18

| LECTURE | LECTURE TOPIC                                       | KEY ELEMENTS   | LEARNING OBJECTIVES<br>(2 to 3 objectives) |
|---------|---|--|--|
| 1.      | Introduction to IC engines                          | Heat engines, Energy conversion, Concept of automotive force | Understanding (2)                          |
| 2.      | Comparison of Air Standard and Actual Cycles        | General comparison based on working                          | Understanding (2)                          |
| 3.      | Time Loss Factor, Heat Loss Factor                  | Heat Loss Factor   | Analyzing (4)                              |
| 4.      | Exhaust Blow down-Loss due to Gas exchange process  | Exhaust Blow down-Loss                                       | Analyzing (4)                              |
| 5.      | Volumetric Efficiency. Loss due to Rubbing Friction | Volumetric Efficiency  | Understanding (2)                          |
| 6.      | Actual and Fuel-Air Cycles of CI Engines            | Actual and Fuel-Air Cycles                                   | Understanding (2)                          |
| 7.      | IC engines classification                           | classification   | Remembering (1)                            |

|            |  |                    |                   |
|------------|--|--------------------|-------------------|
| <b>8.</b>  | Working principle of SI engines 4 stroke | Working principle  | Evaluating (5)    |
| <b>9.</b>  | Working principle of SI engines 2 stroke | 2 stroke           | Remembering (1)   |
| <b>10.</b> | Working principle of CI engines 4 stroke | CI engines         | Remembering (1)   |
| <b>11.</b> | Valve timing diagrams                    | Valve timing       | Remembering (1)   |
| <b>12.</b> | Port timing diagrams                     | Port timing        | Understanding (1) |
| <b>13.</b> | Fuel supply system in SI engines         | Fuel supply system | Analyzing (4)     |
| <b>14.</b> | Working principle of a simple carburetor | simple carburetor  | Remembering (1)   |
| <b>15.</b> | Fuel injection system in CI engines      | Fuel injection     | Understand (2)    |
| <b>16.</b> | Ignition systems                         | Ignition           | Understanding (2) |
| <b>17.</b> | Cooling systems of IC engines            | Cooling systems    | Remembering (1)   |
| <b>18.</b> | Lubrication systems of IC engines        | Lubrication        | Evaluating (5)    |
|            |  |                    |                   |

## UNIT – 2

NO OF LECTURE HOURS: 17

| LECTURE | LECTURE TOPIC  | KEY ELEMENTS        | LEARNING OBJECTIVES<br>(2 to 3 objectives) |
|---------|--|---------------------|--|
| 1.      | Introduction to combustion of IC engines                 | Introduction        | Analyzing (4)                              |
| 2.      | Normal Combustion and abnormal combustion                | Normal Combustion   | Analyzing (4)                              |
| 3.      | Importance of flame speed and effect of engine variables | flame speed         | Understanding (2)                          |
| 4.      | Importance of flame speed and effect of engine variables | flame speed         | Understanding (2)                          |
| 5.      | Type of Abnormal combustion                              | Abnormal combustion | Remembering (1)                            |
| 6.      | pre-ignition and knocking                                | pre-ignition        | Evaluating (5)                             |
| 7.      | Fuel requirements and fuel rating                        | fuel rating         | Remembering (1)                            |
| 8.      | Anti-knock additives                                     | additives           | Remembering (1)                            |
| 9.      | combustion chamber – requirements, types                 | combustion chamber  | Remembering (1)                            |

|            |   |                      |                   |
|------------|---|----------------------|-------------------|
| <b>10.</b> | Combustion in CI engines  | Combustion           | Understanding (1) |
| <b>11.</b> | Four stages of combustion   | stages of combustion | Analyzing (4)     |
| <b>12.</b> | Delay period and its importance   | Delay period         | Remembering (1)   |
| <b>13.</b> | Effect of engine variables  | engine variables     | Understand (2)    |
| <b>14.</b> | Diesel Knock  | Diesel Knock         | Understanding (2) |
| <b>15.</b> | Need for air movement, suction, compression and combustion induced turbulence | turbulence           | Remembering (1)   |
| <b>16.</b> | combustion chambers and nozzles   | nozzles              | Evaluating (5)    |
| <b>17.</b> | fuel requirements and fuel rating   | fuel requirements    | Remembering (1)   |

## UNIT – 3

NO OF LECTURE HOURS: 17

| LECTURE | LECTURE TOPIC                                       | KEY ELEMENTS            | LEARNING OBJECTIVES<br>(2 to 3 objectives) |
|---------|---|-------------------------|--|
| 1.      | Testing and performance of IC engines               | Testing                 | Analyzing (4)                              |
| 2.      | Performance parameters                              | Performance parameters  | Analyzing (4)                              |
| 3.      | Performance parameters                              | Performance             | Understanding (2)                          |
| 4.      | Measurement of cylinder pressure, fuel consumption, | cylinder pressure       | Understanding (2)                          |
| 5.      | Measurement of cylinder pressure, fuel consumption, | fuel consumption        | Remembering (1)                            |
| 6.      | Air intake, exhaust gas composition                 | Air intake              | Evaluating (5)                             |
| 7.      | Air intake, exhaust gas composition                 | exhaust gas composition | Remembering (1)                            |
| 8.      | Air intake, exhaust gas composition                 | exhaust gas composition | Remembering (1)                            |

|            |                                    |                   |                   |
|------------|------------------------------------|-------------------|-------------------|
| <b>9.</b>  | Brake power                        | Brake power       | Remembering (1)   |
| <b>10.</b> | Determination of frictional losses | frictional losses | Understanding (1) |
| <b>11.</b> | frictional losses                  | frictional losses | Analyzing (4)     |
| <b>12.</b> | Performance test                   | Performance test  | Remembering (1)   |
| <b>13.</b> | Performance test                   | Performance test  | Understand (2)    |
| <b>14.</b> | Performance test                   | Performance test  | Understanding (2) |
| <b>15.</b> | Heat balance sheet and chart       | Heat balance      | Remembering (1)   |
| <b>16.</b> | Heat balance sheet and chart       | Heat balance      | Evaluating (5)    |
| <b>17.</b> | Heat balance sheet and chart       | Heat balance      | Remembering (1)   |

## UNIT – 4

NO OF LECTURE HOURS: 26

| LECTURE | LECTURE TOPIC                                    | KEY ELEMENTS           | LEARNING OBJECTIVES<br>(2 to 3 objectives) |
|---------|--|------------------------|--|
| 1.      | <b>Compressors</b> – Classification              | Classification         | Understanding (1)                          |
| 2.      | positive displacement and roto dynamic machinery | positive displacement  | Analyzing (4)                              |
| 3.      | positive displacement and roto dynamic machinery | roto dynamic machinery | Remembering (1)                            |
| 4.      | Power producing and power absorbing machines     | Power producing        | Understand (2)                             |
| 5.      | Power producing and power absorbing machines     | power absorbing        | Understanding (2)                          |
| 6.      | fan, blower and compressor                       | fan, blower            | Remembering (1)                            |
| 7.      | fan, blower and compressor                       | compressor             | Evaluating (5)                             |

|     |   |                        |                   |
|-----|---|------------------------|-------------------|
| 8.  | positive displacement and dynamic types                 | dynamic types          | Remembering (1)   |
| 9.  | reciprocating and rotary types                          | reciprocating          | Analyzing (4)     |
| 10. | reciprocating and rotary types                          | rotary types           | Analyzing (4)     |
| 11. | <b>Reciprocating Compressors</b> Principle of operation | Principle of operation | Understanding (2) |
| 12. | work required   | work required          | Understanding (2) |
| 13. | Isothermal efficiency                                   | Isothermal efficiency  | Remembering (1)   |
| 14. | volumetric efficiency                                   | volumetric efficiency  | Evaluating (5)    |
| 15. | volumetric efficiency                                   | volumetric efficiency  | Remembering (1)   |
| 16. | Effect of clearance                                     | clearance              | Remembering (1)   |
| 17. | Stage compression                                       | Stage compression      | Remembering (1)   |

|     |  |                        |                   |
|-----|--|------------------------|-------------------|
| 18. | Undercooling   | Undercooling           | Understanding (1) |
| 19. | Saving of work                                       | Saving of work         | Analyzing (4)     |
| 20. | Minimum work condition for stage compression         | Minimum work           | Remembering (1)   |
| 21. | <b>Rotary compressors</b> Positive displacement type | Rotary compressors     | Understanding (2) |
| 22. | Roots Blower   | Roots Blower           | Understanding (2) |
| 23. | Vane sealed compressor                               | Vane sealed compressor | Remembering (1)   |
| 24. | Lysholm compressor                                   | Lysholm compressor     | Evaluating (5)    |
| 25. | Mechanical details and principle of working          | working                | Remembering (1)   |
| 26. | Efficiency considerations                            | Efficiency             | Remembering (1)   |

## UNIT – 5

NO OF LECTURE HOURS: 25

| LECTURE | LECTURE TOPIC                                 | KEY ELEMENTS            | LEARNING OBJECTIVES<br>(2 to 3 objectives) |
|---------|---|-------------------------|--|
| 1.      | Centrifugal compressors:                      | Centrifugal compressors | Understanding (1)                          |
| 2.      | Mechanical details and principle of operation | principle of operation  | Analyzing (4)                              |
| 3.      | Mechanical details and principle of operation | principle of operation  | Remembering (1)                            |
| 4.      | Velocity and pressure variation               | Velocity and pressure   | Understand (2)                             |
| 5.      | Velocity and pressure variation               | Velocity and pressure   | Understanding (2)                          |
| 6.      | Energy transfer                               | Energy transfer         | Remembering (1)                            |
| 7.      | Impeller blade shape                          | Impeller                | Evaluating (5)                             |
| 8.      | Losses  | Losses                  | Remembering (1)                            |
| 9.      | Slip factor                                   | Slip factor             | Analyzing (4)                              |

|     |                                  |                        |                   |
|-----|----------------------------------|------------------------|-------------------|
| 10. | Power input factor               | Power input factor     | Analyzing (4)     |
| 11. | Pressure coefficient             | Pressure coefficient   | Understanding (2) |
| 12. | Adiabatic coefficient            | Adiabatic coefficient  | Understanding (2) |
| 13. | Velocity diagrams                | Velocity diagrams      | Remembering (1)   |
| 14. | Power of centrifugal compressors | Power                  | Evaluating (5)    |
| 15. | Axial flow compressors           | Axial flow compressors | Remembering (1)   |
| 16. | Mechanical details               | Mechanical details     | Remembering (1)   |
| 17. | Principle of operation           | Principle of operation | Remembering (1)   |
| 18. | velocity triangles               | velocity triangles     | Understanding (1) |
| 19. | Energy transfer per stage        | Energy transfer        | Analyzing (4)     |
| 20. | Degree of reaction               | Degree of reaction     | Remembering (1)   |
| 21  | Work done factor                 | Work done factor       | Understanding (2) |

|     |                            |                       |                   |
|-----|----------------------------|-----------------------|-------------------|
| 22. | Isentropic efficiency      | Isentropic efficiency | Understanding (2) |
| 23. | Pressure rise calculations | Pressure rise         | Remembering (1)   |
| 24. | pressure rise calculations | Pressure rise         | Evaluating (5)    |
| 25. | Polytropic efficiency      | Polytropic efficiency | Remembering (1)   |



---

# UNIT 1

## ACTUAL CYCLES & ANALYSIS

---





# 1

## Introduction

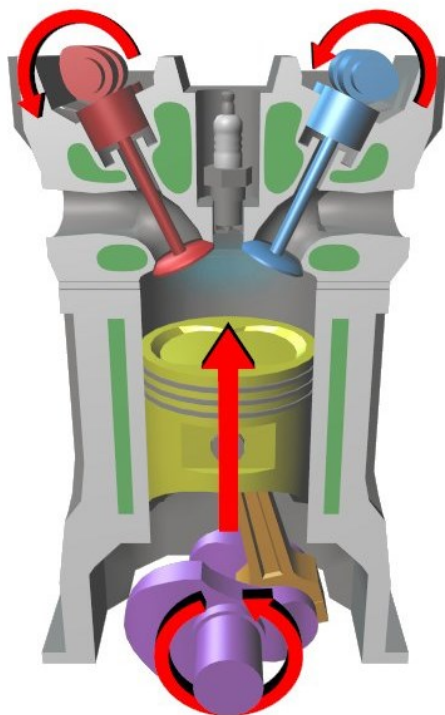

### ***Course Contents***

- 1.1 Introduction
- 1.2 Basic components and terminology of IC engine
- 1.3 Working of 4-Stroke SI engine
- 1.4 Working of 4-Stroke CI engine
- 1.5 Comparison of SI and CI Engines
- 1.6 Two-Stroke Engine
- 1.7 IC Engine classification
- 1.8 Application of IC Engine
- 1.9 Engine Performance Parameters
- 1.10 Air standard cycles

## 1.1 Introduction

- Once man discovered the use of heat in the form of fire, it was just a step to formulate the energy interactions. With this, human beings started to use heat energy for cooking, warming up living spaces, drying and so on.
- Further, due to the development of civilization and increase in population, man had to move from one place to another. Animals were used in transportation between the 4<sup>th</sup> and 5<sup>th</sup> centuries BC, and spread to Europe and other countries in the 5<sup>th</sup> century BC and China in about 1200 BC.
- Gradually, man replaced the animals with motive power that was used in transportation. The use of power vehicles began in the late 18th century, with the creation of the steam engine. The invention of Otto (1876) and Diesel (1892) cycles in the 19th century transformed the method of propulsion from steam to petroleum fuel.
- **ENGINE:** Engine is a device which converts one form of Energy into another form
- **HEAT ENGINE:** Heat engine is a device which transforms the chemical energy of a fuel into thermal energy and utilizes this thermal energy to perform useful work. Thus, thermal energy is converted to mechanical energy in a heat engine.
- Heat engines can be broadly classified into two categories:
  - a) Internal Combustion Engines (IC Engines)
  - b) External Combustion Engines (EC Engines)

### 1.1.1 Classification of heat engines

- Engines whether Internal Combustion or External Combustion are of two types:
  - (i) Rotary engines
  - (ii) Reciprocating engines
- A detailed classification of heat engines is given in Fig. 1.1.

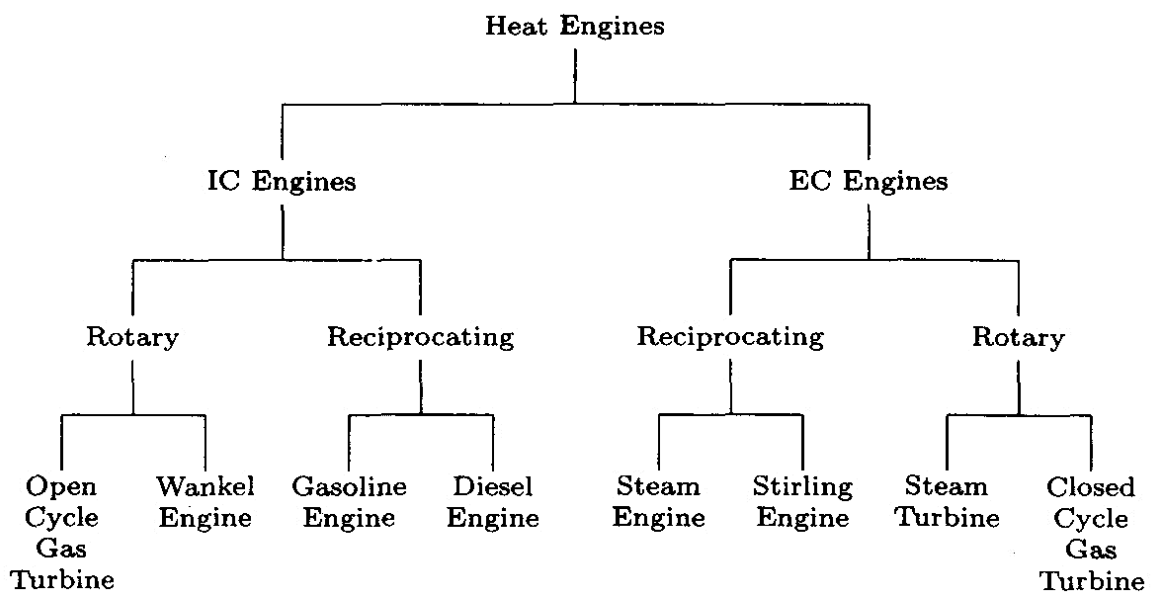

Fig 1.1 Classification of heat engines

### 1.1.2 Comparison of I.C. Engines and E.C. Engines

- Comparison of IC engine and EC engine is given in table 1.1.

Table 1.1 Comparison of IC engine and EC engine

| I.C. Engine   | E.C. engine  |
|---|--|
| 1. Combustion of fuel takes place inside the cylinder           | 1. Combustion of fuel takes place outside the cylinder     |
| 2. Working fluid may be Petrol, Diesel & Various types of gases | 2. Working fluid is steam                                  |
| 3. Require less space   | 3. Require large space                                     |
| 4. Capital cost is relatively low                               | 4. Capital cost is relatively high                         |
| 5. Starting of this engine is easy & quick                      | 5. Starting of this engine requires time                   |
| 6. Thermal efficiency is high                                   | 6. Thermal Efficiency is low                               |
| 7. Power developed per unit weight of these engines is high     | 7. Power Developed per unit weight of these engines is low |
| 8. Fuel cost is relatively high                                 | 8. Fuel cost is relatively low                             |

### 1.2 Basic components and terminology of IC engines

- Even though reciprocating internal combustion engines look quite simple, they are highly complex machines. There are many components which have to perform their functions effectively to produce output power.
- There are two types of engines, viz., spark-ignition (SI) and compression-ignition (CI) engine.

#### 1.2.1 Engine Components

- A cross section of a single cylinder spark-ignition engine with overhead valves is shown in Fig.1.2. The major components of the engine and their functions are briefly described below.

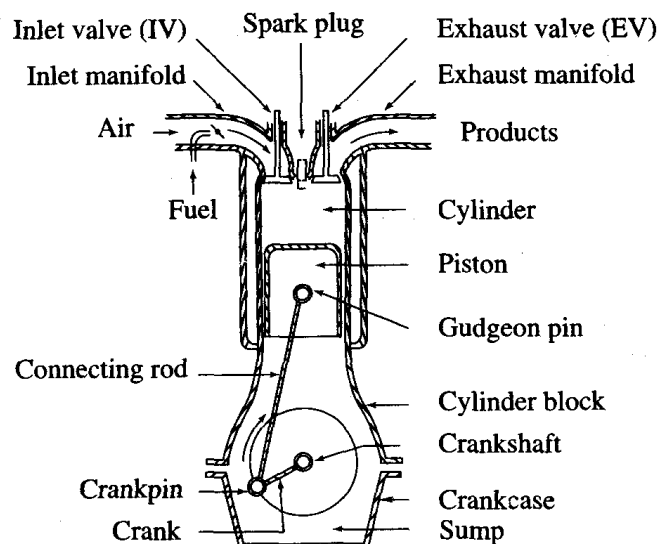

Fig. 1.2 Cross-section of spark-ignition engine

#### a) Cylinder block

- The cylinder block is the main supporting structure for the various components. The cylinder of a multicylinder engine are cast as a single unit, called cylinder block. The

cylinder head is mounted on the cylinder block. The cylinder head and cylinder block are provided with water jackets in the case of water cooling or with cooling fins in the case of air cooling.

**b) Cylinder**

- As the name implies it is a cylindrical vessel or space in which the piston makes a reciprocating motion. The varying volume created in the cylinder during the operation of the engine is filled with the working fluid and subjected to different thermodynamic processes. The cylinder is supported in the cylinder block.

**c) Piston**

- It is a cylindrical component fitted into the cylinder forming the moving boundary of the combustion system. It fits perfectly (snugly) into the cylinder providing a gas-tight space with the piston rings and the lubricant. It forms the first link in transmitting the gas forces to the output shaft.

**d) Combustion chamber**

- The space enclosed in the upper part of the cylinder, by the cylinder head and the piston top during the combustion process, is called the combustion chamber. The combustion of fuel and the consequent release of thermal energy results in the building up of pressure in this part of the cylinder.

**e) Inlet manifold**

- The pipe which connects the intake system to the inlet valve of the engine and through which air or air-fuel mixture is drawn into the cylinder is called the inlet manifold.

**f) Exhaust manifold**

- The pipe which connects the exhaust system to the exhaust valve of the engine and through which the products of combustion escape into the atmosphere is called the exhaust manifold.

**g) Inlet and Exhaust valves**

- Valves are commonly mushroom shaped pop-pet type. They are provided either on the cylinder head or on the side of the cylinder for regulating the charge coming into the cylinder (inlet valve) and for discharging the products of combustion (exhaust valve) from the cylinder.

**h) Spark Plug**

- It is a component to initiate the combustion process in Spark- Ignition (SI) engines and is usually located on the cylinder head.

**i) Connecting Rod**

- It interconnects the piston and the crankshaft and transmits the gas forces from the piston to the crankshaft. The two ends of the connecting rod are called as small end and the big end (Fig.1.3). Small end is connected to the piston by gudgeon pin and the big end is connected to the crankshaft by crankpin.

**j) Crankshaft**

- It converts the reciprocating motion of the piston into useful rotary motion of the output shaft. In the crankshaft of a single cylinder engine there are a pair of crank arms

and balance weights. The balance weights are provided for static and dynamic balancing of the rotating system. The crankshaft is enclosed in a crankcase.

**k) Piston rings**

- Piston rings, fitted into the slots around the piston, provide a tight seal between the piston and the cylinder wall thus preventing leakage of combustion gases.

**l) Gudgeon pin**

- It links the small end of the connecting rod and the piston.

**m) Camshaft**

- The camshaft (not shown in the figure) and its associated parts control the opening and closing of the two valves. The associated parts are push rods, rocker arms, valve springs and tappets. This shaft also provides the drive to the ignition system. The camshaft is driven by the crankshaft through timing gears.

**n) Cams**

- These are made as integral parts of the camshaft and are so de-signed to open the valves at the correct timing and to keep them open for the necessary duration.

**o) Flywheel**

- The net torque imparted to the crankshaft during one complete cycle of operation of the engine fluctuates causing a change in the angular velocity of the shaft. In order to achieve a uniform torque an inertia mass in the form of a wheel is attached to the output shaft and this wheel is called the flywheel.

**p) Carburetor**

- Carburetor is used in petrol engine for proper mixing of air and petrol.

**q) Fuel pump**

- Fuel pump is used in diesel engine for increasing pressure and controlling the quantity of fuel supplied to the injector.

**r) Fuel injector**

- Fuel injector is used to inject diesel fuel in the form of fine atomized spray under pressure at the end of compression stroke.

### **1.2.2 Terminologies used in IC engine**

- **Cylinder Bore (d):** The nominal inner diameter of the working cylinder is called the cylinder bore and is designated by the letter d and is usually expressed in millimeter (mm).
- **Piston Area (A):** The area of a circle of diameter equal to the cylinder bore is called the piston area and is designated by the letter A and is usually expressed in square centimeter (cm<sup>2</sup>).
- **Stroke (L):** It is the linear distance traveled by the piston when it moves from one end of the cylinder to the other end. It is equal to twice the radius of the crank. It is designated by the letter L and is expressed usually in millimeter (mm).

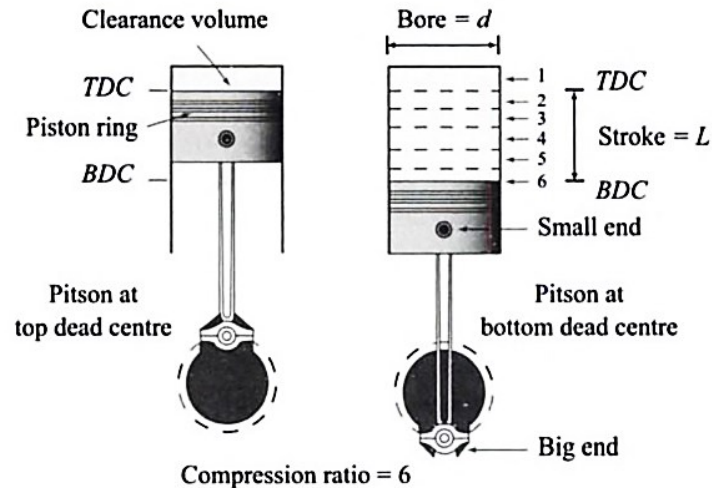

Fig 1.3 IC Engine nomenclature

- **Stroke to Bore Ratio (L/d):** L / d ratio is an important parameter in classifying the size of the engine.
  - If  $d < L$ , it is called under-square engine.
  - If  $d = L$ , it is called square engine.
  - If  $d > L$ , it is called over-square engine.

An over-square engine can operate at higher speeds because of larger bore and shorter stroke.

- **Dead Centre:**

In the vertical engines, top most position of the piston is called Top Dead Centre (TDC). When the piston is at bottom most position, it is called Bottom Dead Centre (BDC).

In horizontal engine, the extreme position of the piston near to cylinder head is called Inner Dead Centre (IDC.) and the extreme position of the piston near the crank is called Outer Dead Centre (O.D.C.).

- **Displacement or Swept Volume ( $V_s$ ):** The volume displaced by the piston in one stroke is known as stroke volume or swept volume. It is expressed in terms of cubic centimeter (cc) and given by

$$V_s = A \times L = \frac{\pi}{4} d^2 L$$

- **Cubic Capacity or Engine Capacity:** The displacement volume of a cylinder multiplied by number of cylinders in an engine will give the cubic capacity or the engine capacity. For example, if there are K cylinders in an engine, then

$$\text{Cubic capacity} = V_s \times K$$

- **Clearance Volume ( $V_c$ ):** It is the volume contained between the piston top and cylinder head when the piston is at top or inner dead center.
- **Compression Ratio (r):** The ratio of total cylinder volume to clearance volume is called the compression ratio (r) of the engine.

$$r = \frac{\text{Total cylinder volume}}{\text{Clearance volume}}$$

$$\therefore r = \frac{V_c + V_s}{V_c}$$

For petrol engine  $r$  varies from 6 to 10 and for Diesel engine  $r$  varies from 14 to 20.

- **Piston speed ( $V_p$ ):** It is average speed of piston. It is equal to  $2LN$ , where  $N$  is speed of crank shaft in rev/sec.

$$V_p = \frac{2LN}{60} \text{ m/sec}$$

where,  $L$  = Stroke length, m

$N$  = Speed of crank shaft, RPM

### 1.3 Working of Four Stroke Spark-Ignition Engine

- In a four-stroke engine, the cycle of operations is completed in four strokes of the piston or two revolutions of the crankshaft.
- During the four strokes, there are five events to be completed, viz., suction, compression, combustion, expansion and exhaust. Each stroke consists of  $180^\circ$  of crankshaft rotation and hence a four-stroke cycle is completed through  $720^\circ$  of crank rotation.
- The cycle of operation for an ideal four-stroke SI engine consists of the following four strokes: (i) suction or intake stroke; (ii) compression stroke; (iii) expansion or power stroke and (iv) exhaust stroke.

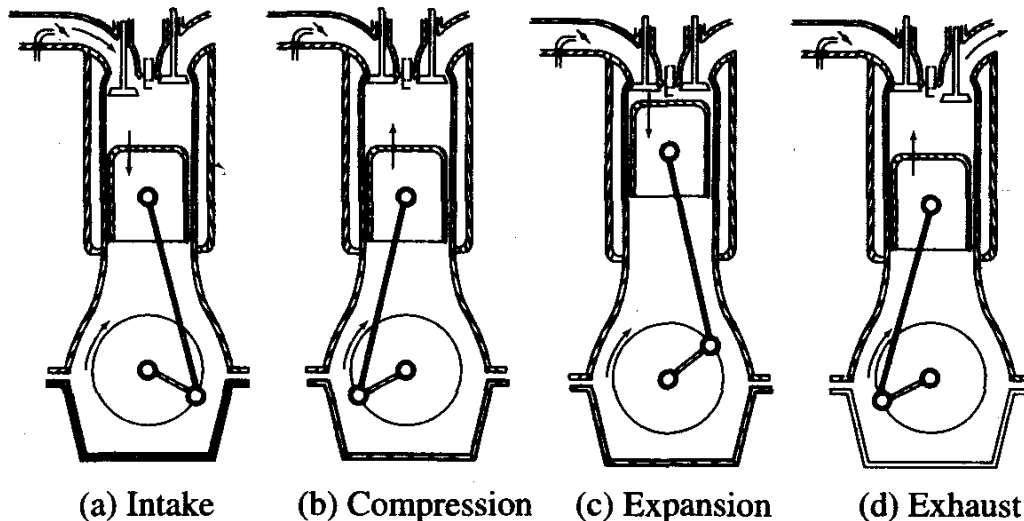

*Fig. 1.4 Working principle of a four-stroke SI engine*

- The details of various processes of a four-stroke spark-ignition engine with overhead valves are shown in Fig. 1.4 (a-d). When the engine completes all the five events under ideal cycle mode, the pressure-volume ( $p$ - $V$ ) diagram will be as shown in Fig.1.5.

**a) Suction or Intake Stroke:** Suction stroke 0→1 (Fig.1.5) starts when the piston is at the top dead centre and about to move downwards. The inlet valve is assumed to open instantaneously and at this time the exhaust valve is in the closed position, Fig.1.4 (a).

- Due to the suction created by the motion of the piston towards the bottom dead centre, the charge consisting of fuel-air mixture is drawn into the cylinder. When the piston reaches the bottom dead centre the suction stroke ends and the inlet valve closes instantaneously.

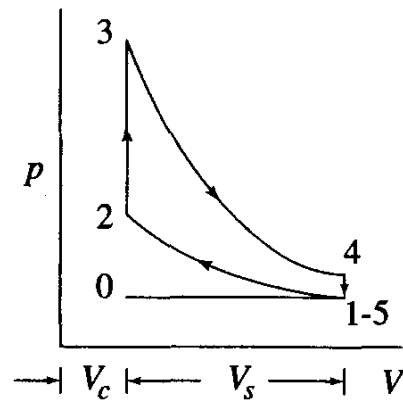

Fig. 1.5 Ideal  $p$ - $V$  diagram of a four-stroke SI engine

**b) Compression Stroke:** The charge taken into the cylinder during the suction stroke is compressed by the return stroke of the piston 1→2, (Fig.1.5). During this stroke both inlet and exhaust valves are in closed position, Fig. 1.4(b).

- The mixture which fills the entire cylinder volume is now compressed into the clearance volume. At the end of the compression stroke the mixture is ignited with the help of a spark plug located on the cylinder head.
- In ideal engines it is assumed that burning takes place instantaneously when the piston is at the top dead centre and hence the burning process can be approximated as heat addition at constant volume.
- During the burning process the chemical energy of the fuel is converted into heat energy producing a temperature rise of about 2000 °C (process 2→3), Fig.1.5. The pressure at the end of the combustion process is considerably increased due to the heat release from the fuel.

**c) Expansion or Power Stroke:** The high pressure of the burnt gases forces the piston towards the BDC, (stroke 3→4) Fig .1.5. Both the valves are in closed position, Fig. 1.4(c). Of the four-strokes only during this stroke power is produced. Both pressure and temperature decrease during expansion.

**d) Exhaust Stroke:** At the end of the expansion stroke the exhaust valve opens instantaneously and the inlet valve remains closed, Fig. 1.4(d). The pressure falls to atmospheric level a part of the burnt gases escape. The piston starts moving from the bottom dead centre to top dead centre (stroke 5→0), Fig.1.5 and sweeps the burnt gases out from the cylinder almost at atmospheric pressure. The exhaust valve closes when the piston reaches TDC.

- At the end of the exhaust stroke and some residual gases trapped in the clearance volume remain in the cylinder. These residual gases mix with the fresh charge coming in during the following cycle, forming its working fluid.

- Each cylinder of a four-stroke engine completes the above four operations in two engine revolutions, first revolution of the crankshaft occurs during the suction and compression strokes and the second revolution during the power and exhaust strokes.
- Thus for one complete cycle there is only one power stroke while the crankshaft makes two revolutions. For getting higher output from the engine the heat addition (process 2→3) should be as high as possible and the heat rejection (process 3→4) should be as small as possible. Hence, one should be careful in drawing the ideal p - V diagram (Fig.1.5), which should represent the processes correctly.

### 1.4 Working of Four Stroke Compression-Ignition Engine

- The four-stroke CI engine is similar to the four-stroke SI engine but it operates at a much higher compression ratio. The compression ratio of an SI engine is between 6 and 10 while for a CI engine it is from 16 to 20.
- In the CI engine during suction stroke, air, instead of a fuel-air mixture, is inducted. Due to higher compression ratios employed, the temperature at the end of the compression stroke is sufficiently high to self-ignite the fuel which is injected into the combustion chamber.
- In CI engines, a high pressure fuel pump and an injector are provided to inject the fuel into the combustion chamber. The carburetor and ignition system necessary in the SI engine are not required in the CI engine.
- The ideal sequence of operations for the four-stroke CI engine as shown in Fig. 1.6 is as follows:

a) **Suction Stroke:** In the suction stroke piston moves from TDC to BDC. Air alone is inducted during the suction stroke. During this stroke inlet valve is open and exhaust valve is closed, Fig.1.6 (a).

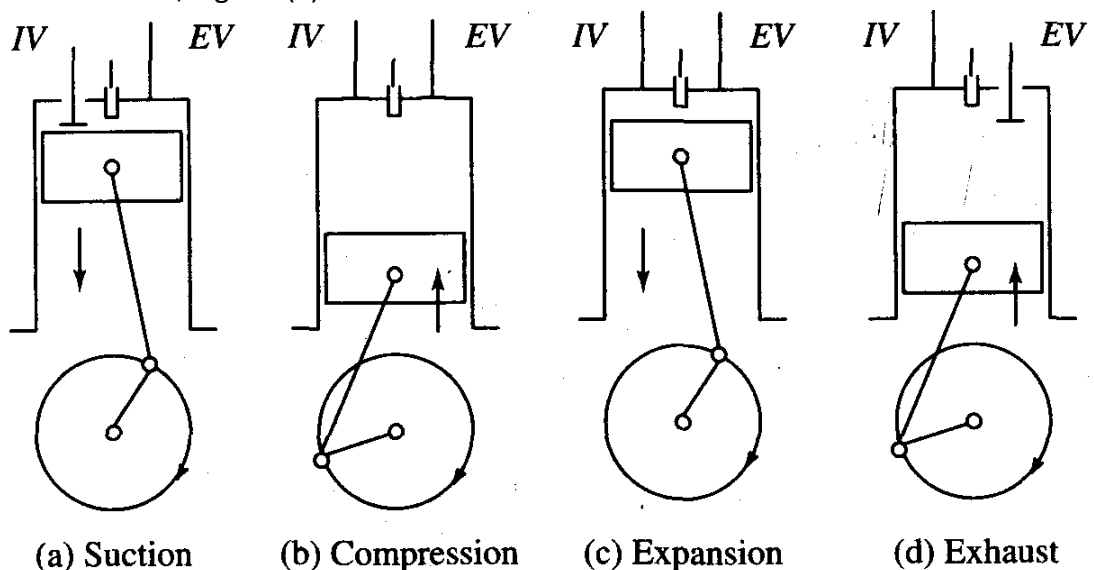

Fig. 1.6 Cycle of operation of CI engine

b) **Compression Stroke:** In this stroke piston moves from BDC to TDC. Air inducted during the suction stroke is compressed into the clearance volume. Both valves remain closed during this stroke, Fig. 1.6 (b).

c) **Expansion Stroke:** Fuel injection starts nearly at the end of the compression stroke. The rate of injection is such that combustion maintains the pressure constant in spite of the piston movement on its expansion stroke increasing the volume. Heat is assumed to have been added at constant pressure. After the injection of fuel is completed (i.e. after cut-off) the products of combustion expand. Both the valves remain closed during the expansion stroke, Fig. 1.6(c).

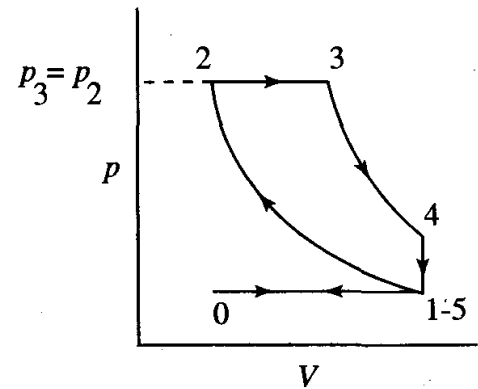

Fig. 1.7 Ideal p-V diagram for a four stroke CI engine

d) **Exhaust Stroke:** The piston travelling from BDC to TDC pushes out the products of combustion. The exhaust valve is open and the intake valve is closed during this stroke, Fig. 1.6 (d). The ideal p - V diagram is shown in Fig. 1.7.

- Due to higher pressures in the cycle of operations the CI engine has to be sturdier than a SI engine for the same output. This results in a CI engine being heavier than the SI engine. However, it has a higher thermal efficiency on account of the high compression ratio (of about 18 as against about 8 in SI engines) used.

## 1.5 Comparison of SI and CI Engines

- The detailed comparison of SI and CI engine is given in table 1.2

Table 1.2 Comparison of SI and CI Engines

| Description                 | SI Engine   | CI Engine  |
|-----------------------------|---|--|
| <b>Basic cycle</b>          | Works on Otto cycle or constant volume heat addition cycle.   | Works on Diesel cycle or constant pressure heat addition cycle.  |
| <b>Fuel</b>                 | Gasoline, a highly volatile fuel. Self-ignition temperature is high.  | Diesel oil, a non-volatile fuel. Self-ignition temperature is comparatively low  |
| <b>Introduction of fuel</b> | A gaseous mixture of fuel-air is introduced during the suction stroke. A carburetor and an ignition system are necessary. Modern engines have gasoline injection. | Fuel is injected directly into the combustion chamber at high pressure at the end of the compression stroke. A fuel pump and injector are necessary. |
| <b>Load control</b>         | Throttle controls the quantity of fuel-air mixture to control the load.   | The quantity of fuel is regulated to control the load. Air quantity is not controlled.   |

|                           |  |  |
|---------------------------|--|--|
| <b>Ignition</b>           | Requires an ignition system with spark plug in the combustion chamber. Primary voltage is provided by either a battery or a magneto. | Self-ignition occurs due to high temperature of air because of the high compression. Ignition system and spark plug are not necessary. |
| <b>Compression ratio</b>  | 6 to 10. Upper limit is fixed by anti-knock quality of the fuel.   | 16 to 20. Upper limit is limited by weight increase of the engine.   |
| <b>Speed</b>              | Due to light weight and also due to homogeneous combustion, they are high speed engines.   | Due to heavy weight and also due to heterogeneous combustion, they are low speed engines.  |
| <b>Thermal efficiency</b> | Because of the lower CR, the maximum value of thermal efficiency that can be obtained is lower.                                      | Because of higher CR, the maximum value of thermal efficiency that can be obtained is higher.  |
| <b>Weight</b>             | Lighter due to comparatively lower peak pressures.   | Heavier due to comparatively higher peak pressures.  |

## 1.6 Two-Stroke Engine

- In two-stroke engines the cycle is completed in one revolution of the crankshaft. The main difference between two-stroke and four-stroke engines is in the method of filling the fresh charge and removing the burnt gases from the cylinder.
- In the four-stroke engine these operations are performed by the engine piston during the suction and exhaust strokes respectively.
- In a two-stroke engine, the filling process is accomplished by the charge compressed in crankcase or by a blower. The induction of the compressed charge moves out the product of combustion through exhaust ports. Therefore, no separate piston strokes are required for these two operations.
- Two strokes are sufficient to complete the cycle, one for compressing the fresh charge and the other for expansion or power stroke. It is to be noted that the effective stroke is reduced.
- Figure 1.8 shows one of the simplest two-stroke engines, viz., the crankcase scavenged engine. Figure 1.9 shows the ideal  $p - V$  diagram of such an engine.
- The air-fuel charge is inducted into the crankcase through the spring loaded inlet valve when the pressure in the crankcase is reduced due to upward motion of the piston during compression stroke. After the compression and ignition, expansion takes place in the usual way.
- During the expansion stroke the charge in the crankcase is compressed. Near the end of the expansion stroke, the piston uncovers the exhaust ports and the cylinder pressure drops to atmospheric pressure as the combustion products leave the cylinder.
- Further movement of the piston uncovers the transfer ports, permitting the slightly compressed charge in the crankcase to enter the engine cylinder.

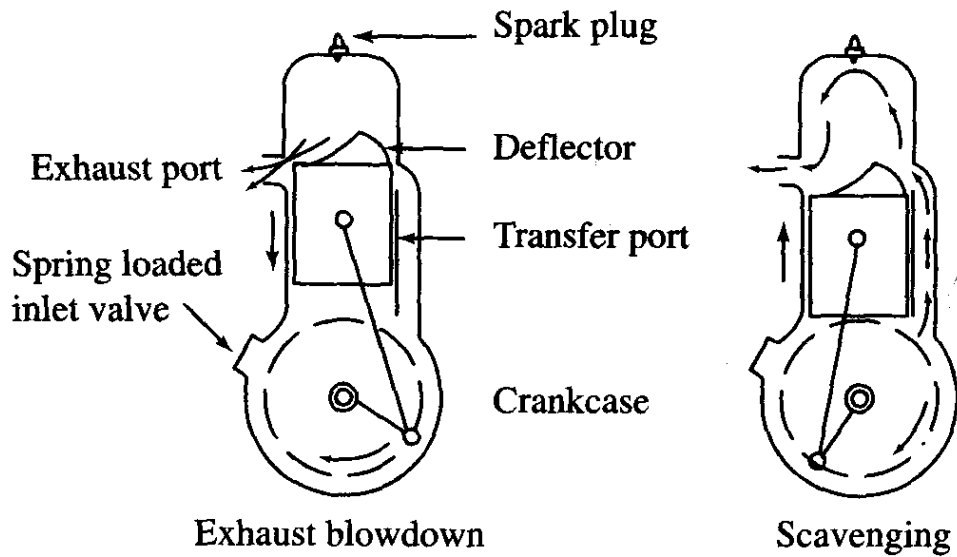

Fig. 1.8 Crankcase scavenged two-stroke SI engine

- The piston top usually has a projection to deflect the fresh charge towards the top of the cylinder preventing the flow through the exhaust ports. This serves the double purpose of scavenging the combustion products from the upper part of the cylinder and preventing the fresh charge from flowing out directly through the exhaust ports.
- The same objective can be achieved without piston deflector by proper shaping of the transfer port. During the upward motion of the piston from B D C the transfer ports close first and then the exhaust ports, thereby the effective compression of the charge begins and the cycle is repeated.

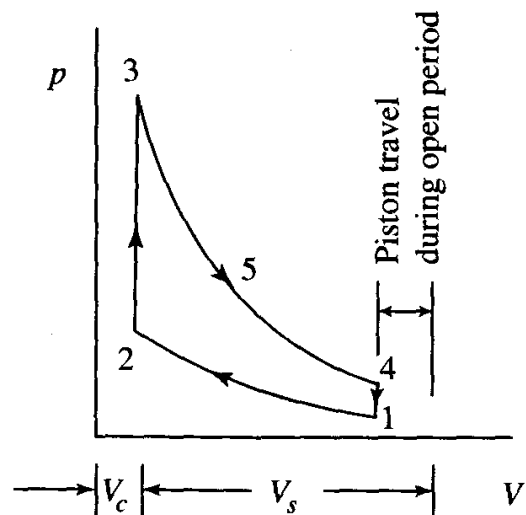

Fig 1.9 Ideal  $p$ - $V$  diagram of a two-stroke SI engine

## 1.7 IC engine Classification

- I.C. Engines may be classified according to,
  - a) Type of the fuel used as :
    - (1) Petrol engine
    - (2) Diesel engine
    - (3) Gas engine
    - (4) Bi-fuel engine (Two fuel engine)
  - b) Nature of thermodynamic cycle as :
    - (1) Otto cycle engine
    - (2) Diesel cycle engine
    - (3) Duel or mixed cycle engine
  - c) Number of strokes per cycle as :
    - (1) Four stroke engine
    - (2) Two stroke engine

- d) Method of ignition as :
- (1) Spark ignition engine (S.I. engine)  
Mixture of air and fuel is ignited by electric spark.
  - (2) Compression ignition engine (C.I. engine)  
The fuel is ignited as it comes in contact with hot compressed air.
- e) Method of cooling as :
- (1) Air cooled engine      (2) Water cooled engine
- f) Speed of the engine as :
- (1) Low speed      (2) Medium speed
  - (3) High speed
- Petrol engine are high speed engines and diesel engines are low to medium speed engines
- g) Number of cylinder as :
- (1) Single cylinder engine (2) Multi cylinder engine
- h) Position of the cylinder as :
- (1) Inline engines      (2) V – engines
  - (3) Radial engines      (4) Opposed cylinder engine
  - (5) X – Type engine      (6) H – Type Engine
  - (7)U – Type Engine      (8) Opposed piston engine
  - (9) Delta Type Engine

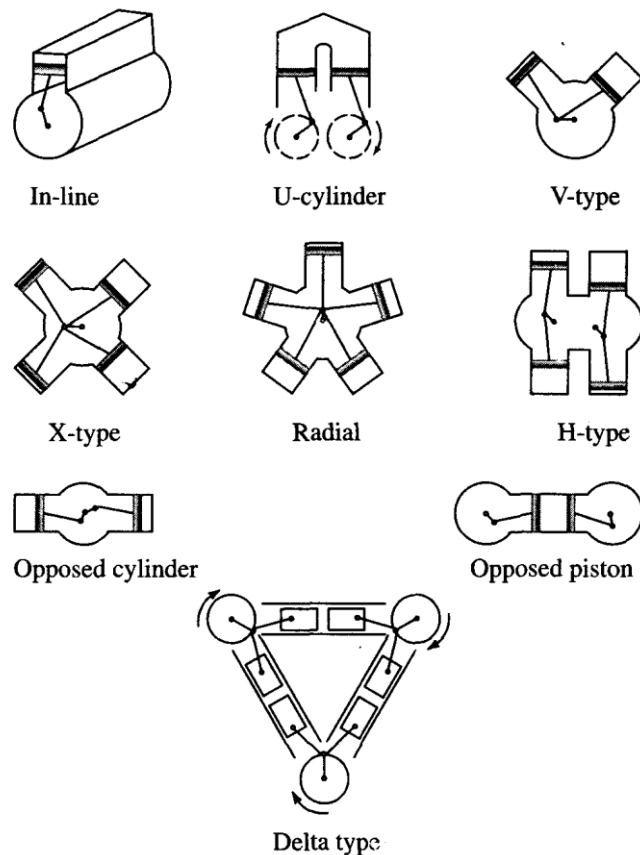

Fig. 1.10 Engine classification by cylinder arrangements

## 1.8 Application of IC Engines

- The most important application of IC engines is in transport on land, sea and air. Other applications include industrial power plants and as prime movers for electric generators. Table 1.3 gives, in a nutshell, the applications of both IC and EC engines.

Table 1.3 Application of Engines

| IC Engine        |                                     | EC Engine               |                             |
|------------------|-------------------------------------|-------------------------|-----------------------------|
| Type             | Application                         | Type                    | Application                 |
| Gasoline engines | Automotive, Marine, Aircraft        | Steam Engines           | Locomotives, Marine         |
| Gas engines      | Industrial power                    | Stirling Engines        | Experimental Space Vehicles |
| Diesel engines   | Automotive, Railways, Power, Marine | Steam Turbines          | Power, Large Marine         |
| Gas turbines     | Power, Aircraft, Industrial, Marine | Close Cycle Gas Turbine | Power, Marine               |

## 1.9 Engine Performance Parameters

- The engine performance is indicated by the term efficiency,  $\eta$ . Five important engine efficiencies and other related engine performance parameters are discussed below.

### 1.9.1 Indicated Power

- The power produced inside the engine cylinder by burning of fuel is known as Indicated power (I.P.) of engine. It is calculated by finding the actual mean effective pressure.

$$\text{Actual mean effective pressure, } P_m = \frac{sa}{l} \frac{N}{m^2} \quad (1.1)$$

where,

a = Area of the actual indicator diagram,  $\text{cm}^2$

l = Base width of the indicator diagram, cm

s = Spring value of the spring used in the indicator,  $\text{N/m}^2/\text{cm}$

$$ip = \frac{P_m L A n}{60000} \text{ kW} \quad (1.2)$$

where,

$P_m$  = Mean effective pressure  $\text{N/m}^2$

L = Length of stroke, m

A = Area of cross section of the cylinder,  $\text{m}^2$

N = RPM of the engine crank shaft

$$n = \frac{N}{2} \quad \text{for 4-stroke}$$

$$n = N \quad \text{for 2-stroke}$$

### 1.9.2 Brake power

- It is the power available at engine crank shaft for doing useful work. It is also known as engine output power. It is measured by dynamometer.

$$B.P. = \frac{2\pi NT}{60000} = \frac{P_{mb}LAN}{60000} kW \quad (1.3)$$

where

$$T = W \times R \quad (1.4)$$

W = Net load acting on the brake drum, N

R = Effective radius of the brake drum, m

N = RPM of the crank shaft

T = Resisting torque, Nm

$P_{mb}$  = Brake mean effective pressure

### 1.9.3 Indicated Thermal Efficiency ( $\eta_{ith}$ )

- Indicated thermal efficiency is the ratio of energy in the indicated power, ip, to the input fuel energy in appropriate units.

$$\eta_{ith} = \frac{ip [kJ/s]}{\text{energy in fuel per second } [kJ/s]} \quad (1.1)$$

$$\eta_{ith} = \frac{ip}{\text{mass of fuel/s} \times CV \text{ of fuel}} = \frac{ip}{m_f \times CV} \quad (1.2)$$

### 1.9.4 Brake Thermal Efficiency ( $\eta_{bth}$ )

- Brake thermal efficiency is the ratio of power available at crank shaft, bp, to the input fuel energy in appropriate units.

$$\eta_{bth} = \frac{bp}{\text{mass of fuel/s} \times CV \text{ of fuel}} = \frac{bp}{m_f \times CV} \quad (1.3)$$

### 1.9.5 Mechanical Efficiency ( $\eta_m$ )

- Mechanical efficiency is defined as the ratio of brake power (delivered power) to the indicated power (power provided to the piston).

$$\eta_m = \frac{bp}{ip} = \frac{bp}{bp + fp} \quad (1.4)$$

$$fp = ip - bp \quad (1.5)$$

### 1.9.6 Volumetric Efficiency ( $\eta_v$ )

- Volumetric efficiency indicates the breathing ability of the engine. It is to be noted that the utilization of the air is that determines the power output of the engine. Intake system must be designed in such a way that the engine must be able to take in as much air as possible.
- Volumetric efficiency is defined as the ratio of actual volume flow rate of air into the intake system to the rate at which the volume is displaced by the system.

$$\eta_v = \frac{\text{Actual volume of charge or air sucked at atm. condition}}{\text{Swept volume}} \quad (1.6)$$

### 1.9.7 Air standard efficiency

- It is the efficiency of the thermodynamic cycle of the engine.
- For petrol engine,

$$\eta_{air} = 1 - \frac{1}{(r)^{\gamma-1}} \quad (1.7)$$

- For diesel engine,

$$\eta_{air} = 1 - \frac{1}{(r)^{\gamma-1}} \left[ \frac{\rho^\gamma - 1}{\gamma(\rho - 1)} \right] \quad (1.8)$$

### 1.9.8 Relative Efficiency or Efficiency Ratio

- Relative efficiency or efficiency ratio is the ratio of thermal efficiency of an actual cycle to that of the ideal cycle. The efficiency ratio is a very useful criterion which indicates the degree of development of the engine.

$$\eta_{rel} = \frac{\eta_{th}}{\eta_{air}} \quad (1.9)$$

### 1.9.9 Specific output

- The specific output of the engine is defined as the power output per unit area.

$$\text{Specific output} = \frac{B.P.}{A} \quad (1.10)$$

### 1.9.10 Specific fuel consumption

- Specific fuel consumption (SFC) is defined as the amount of fuel consumed by an engine for one unit of power production. SFC is used to express the fuel efficiency of an I.C. engine.

$$SFC = \frac{m_f}{B.P.} \text{ k g / kWh} \quad (1.11)$$

## 1.10 Air Standard Cycles

- In most of the power developing systems, such as petrol engine, diesel engine and gas turbine, the common working fluid used is air. These devices take in either a mixture of fuel and air as in petrol engine or air and fuel separately and mix them in the combustion chamber as in diesel engine
- The mass of fuel used compared with the mass of air is rather small. Therefore the properties of mixture can be approximated to the properties of air.
- Exact condition existing within the actual engine cylinder are very difficult to determine, but by making certain simplifying assumptions, it is possible to approximate these conditions more or less closely. The approximate engine cycles thus analysed are known as theoretical cycles.
- The simplest theoretical cycle is called the air-cycle approximation. The air-cycle approximation used for calculating conditions in internal combustion engine is called the air-standard cycle.

- The analysis of all air-standard cycles is based upon the following assumption:
- a) The gas in the engine cylinder is a perfect gas, i.e. it obeys the gas laws and has constant specific heats.
- b) The physical constants of the gas in the cylinder are the same as those of air at moderate temperatures i.e., the molecular weight of cylinder gas is 29 and  $C_p = 1.005$  kJ/kg K and  $C_v = 0.718$  kJ/kg K.
- c) The compression and expansion processes are adiabatic and they take place without internal friction, i.e., these processes are isentropic.
- d) No chemical reaction takes place in the cylinder. Heat is supplied or rejected by bringing a hot body or a cold body in contact with cylinder at appropriate points during the process.
- e) The cycle is considered closed, with the same 'air' always remaining in the cylinder to repeat the cycle.
- Because of many simplifying assumptions, it is clear that the air-cycle approximation does not closely represent the conditions within the actual cylinder. Due to the simplicity of the air-cycle calculation, it is often used to obtain approximate answers to complex engine problems.

### 1.10.1 The Otto Cycle OR Constant Volume Cycle (Isochoric)

- The cycle was successfully applied by a German scientist Nicolous A. Otto to produce a successful 4 – stroke cycle engine in 1876.

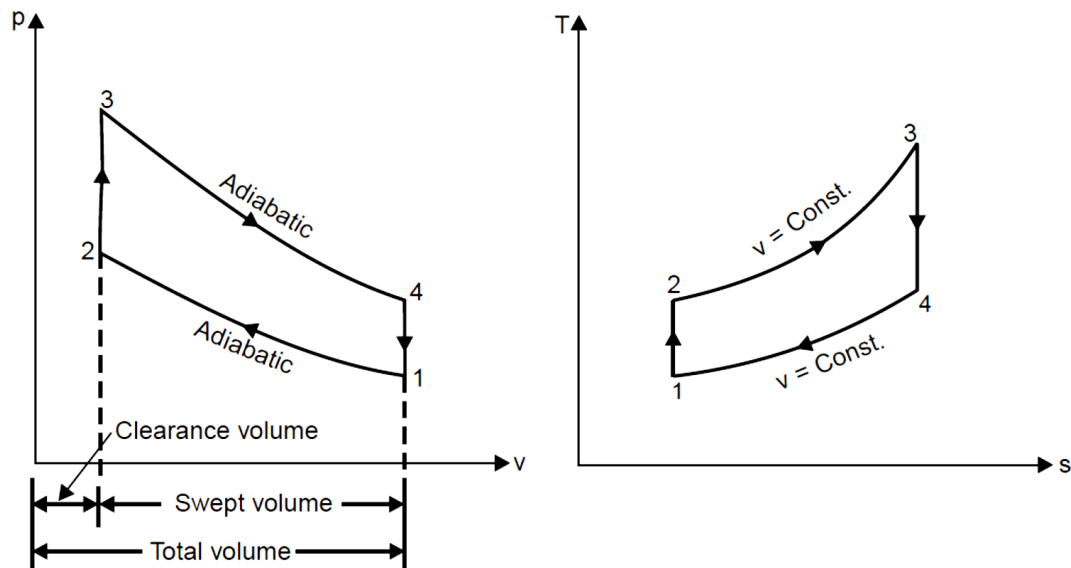

Fig. 1.11 p-V and T-s diagrams of Otto cycle

- The thermodynamic cycle is operated with isochoric (constant volume) heat addition and consists of two adiabatic processes and two constant volume changes.
- Fig. 1.11 shows the Otto cycle plotted on p – V and T – s diagram.

#### Adiabatic Compression Process (1 – 2):

- At pt. 1 cylinder is full of air with volume  $V_1$ , pressure  $P_1$  and temp.  $T_1$ .

- Piston moves from BDC to TDC and an ideal gas (air) is compressed isentropically to state point 2 through compression ratio,

$$r = \frac{V_1}{V_2}$$

**Constant Volume Heat Addition Process (2 – 3):**

- Heat is added at constant volume from an external heat source.
- The pressure rises and the ratio  $r_p$  or  $\alpha = \frac{p_3}{p_2}$  is called expansion ratio or pressure ratio.

**Adiabatic Expansion Process (3 – 4):**

- The increased high pressure exerts a greater amount of force on the piston and pushes it towards the BDC.
- Expansion of working fluid takes place isentropically and work done by the system.
- The volume ratio  $\frac{V_4}{V_3}$  is called isentropic expansion ratio.

**Constant Volume Heat Rejection Process (4 – 1):**

- Heat is rejected to the external sink at constant volume. This process is so controlled that ultimately the working fluid comes to its initial state 1 and the cycle is repeated.
- Many petrol and gas engines work on a cycle which is a slight modification of the Otto cycle.
- This cycle is called constant volume cycle because the heat is supplied to air at constant volume.

**Air Standard Efficiency of an Otto Cycle:**

- Consider a unit mass of air undergoing a cyclic change.
- **Heat supplied** during the process 2 – 3,

$$q_1 = C_v (T_3 - T_2)$$

- **Heat rejected** during process 4 – 1 ,

$$q_2 = C_v (T_4 - T_1)$$

- **Work done,**

$$\begin{aligned} \therefore W &= q_1 - q_2 \\ \therefore W &= C_v (T_3 - T_2) - C_v (T_4 - T_1) \end{aligned}$$

- **Thermal efficiency,**

$$\begin{aligned}
\eta &= \frac{\text{Work done}}{\text{Heat supplied}} = \frac{W}{q_1} \\
&= \frac{C_v (T_3 - T_2) - C_v (T_4 - T_1)}{C_v (T_3 - T_2)} \\
&= 1 - \frac{(T_4 - T_1)}{(T_3 - T_2)} \tag{1.12}
\end{aligned}$$

- For Adiabatic compression process (1 – 2),

$$\begin{aligned}
\frac{T_2}{T_1} &= \left( \frac{V_1}{V_2} \right)^{\gamma-1} = r^{\gamma-1} \\
\therefore T_2 &= T_1 r^{\gamma-1} \tag{1.13}
\end{aligned}$$

- For Isentropic expansion process (3 – 4),

$$\begin{aligned}
\frac{T_4}{T_3} &= \left( \frac{V_3}{V_4} \right)^{\gamma-1} \\
\therefore T_3 &= T_4 \left( \frac{V_4}{V_3} \right)^{\gamma-1} \\
\therefore T_3 &= T_4 \left( \frac{V_1}{V_2} \right)^{\gamma-1} \quad (\because V_1 = V_4, V_2 = V_3) \\
\therefore T_3 &= T_4 (r)^{\gamma-1} \tag{1.14}
\end{aligned}$$

- From equation 1.16, 1.17 & 1.18, we get,

$$\begin{aligned}
\eta_{otto} &= 1 - \frac{(T_4 - T_1)}{T_4 r^{\gamma-1} - T_1 r^{\gamma-1}} \\
\therefore \eta_{otto} &= 1 - \frac{(T_4 - T_1)}{r^{\gamma-1} (T_4 - T_1)} \\
\therefore \eta_{otto} &= 1 - \frac{1}{r^{\gamma-1}} \tag{1.15}
\end{aligned}$$

- Expression 1.19 is known as the air standard efficiency of the Otto cycle.
- It is clear from the above expression that efficiency increases with the increase in the value of  $r$  (as  $\gamma$  is constant).
- We can have maximum efficiency by increasing  $r$  to a considerable extent, but due to practical difficulties its value is limited to 8.
- In actual engines working on Otto cycle, the compression ratio varies from 5 to 8 depending upon the quality of fuel.

- At compression ratios higher than this, the temperature after combustion becomes high and that may lead to spontaneous and uncontrolled combustion of fuel in the cylinder.
- The phenomenon of uncontrolled combustion in petrol engine is called detonation and it leads to poor engine efficiency and in structural damage of engine parts.

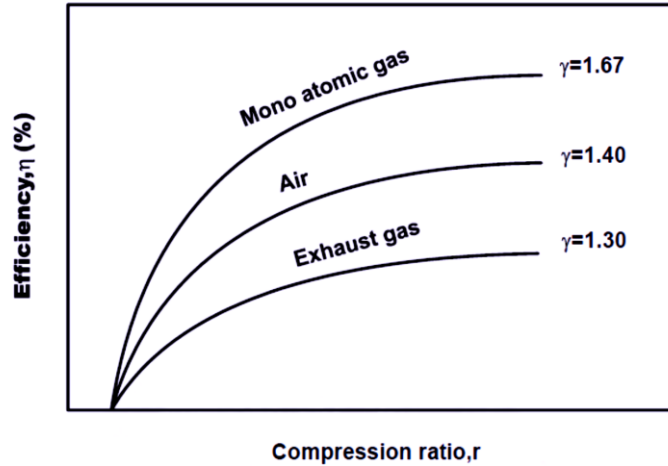

Fig. 1.12 Variation of Otto cycle efficiency with compression ratio

- Fig. 1.12 shows the variation of air standard efficiency of Otto cycle with compression ratio.

### Mean Effective Pressure:

- **Net work done** per unit mass of air,

$$W_{net} = C_v (T_3 - T_2) - C_v (T_4 - T_1) \quad (1.16)$$

- **Swept volume,**

$$\begin{aligned} \text{Swept volume} &= V_1 - V_2 = V_1 \left( 1 - \frac{V_2}{V_1} \right) = \frac{RT_1}{P_1} \left( 1 - \frac{1}{r} \right) \\ &= \frac{RT_1}{P_1 r} (r - 1) \end{aligned} \quad (1.17)$$

- **Mean effective pressure,**

$$\begin{aligned} mep &= \frac{\text{Work done per cycle}}{\text{swept volume}} \\ &= \frac{C_v (T_3 - T_2) - C_v (T_4 - T_1)}{\frac{RT_1}{P_1 r} (r - 1)} \\ &= \frac{C_v}{R} \frac{P_1 r}{(r - 1)} \left[ \frac{(T_3 - T_2) - (T_4 - T_1)}{T_1} \right] \end{aligned} \quad (1.18)$$

- For process 1 – 2,

$$\frac{T_2}{T_1} = \left( \frac{V_1}{V_2} \right)^{\gamma-1}$$

$$T_2 = T_1 r^{\gamma-1}$$

– Process 2 – 3,

$$\frac{T_3}{T_2} = \frac{P_3}{P_2} (\because$$

$$\therefore T_3 = T_2 \alpha \quad (\alpha = \text{explosion pressure ratio})$$

$$\therefore T_3 = T_1 \alpha r^{\gamma-1}$$

– Process 3 – 4,

$$T_4 = T_3 \left( \frac{V_3}{V_4} \right)^{\gamma-1}$$

$$T_4 = T_3 \left( \frac{V_3}{V_4} \right)^{\gamma-1}$$

$$\therefore T_4 = T_1 \alpha r^{\gamma-1} \left( \frac{V_2}{V_1} \right)^{\gamma-1}$$

$$\therefore T_4 = T_1 \alpha r^{\gamma-1} \times \frac{1}{r^{\gamma-1}}$$

$$\therefore T_4 = T_1 \cdot \alpha$$

– Substituting all these temperature values in equation 1.22, We get,

$$mep = \frac{C_v}{R} \frac{P_1 r}{(r-1)} \left[ \frac{(T_1 \alpha r^{\gamma-1} - T_1 r^{\gamma-1}) - (T_1 \alpha - T_1)}{T_1} \right]$$

$$\therefore mep = \frac{C_v}{R} \frac{P_1 r}{(r-1)} \left[ \frac{T_1 r^{\gamma-1} (\alpha - 1) - T_1 (\alpha - 1)}{T_1} \right]$$

$$\therefore mep = \frac{C_v}{R} \frac{P_1 r}{(r-1)} [(r^{\gamma-1} - 1)(\alpha - 1)]$$

$$\therefore mep = \frac{P_1 r}{(r-1)(\gamma-1)} [(r^{\gamma-1} - 1)(\alpha - 1)] \quad (1.19)$$

$$\left( \because \frac{C_v}{R} = \frac{1}{\gamma-1} \right)$$

$$\left[ \begin{array}{l} \frac{C_p}{C_v} = \gamma, \quad C_p - C_v = R, \\ C_v \left( \frac{C_p}{C_v} - 1 \right) = R, \quad \frac{C_v}{R} = \frac{1}{\gamma-1} \end{array} \right]$$

### 1.10.2 The Diesel Cycle OR Constant Pressure Cycle (Isobaric)

- This cycle was discovered by a German engineer Dr. Rudolph Diesel. Diesel cycle is also known as **constant pressure heat addition cycle**.

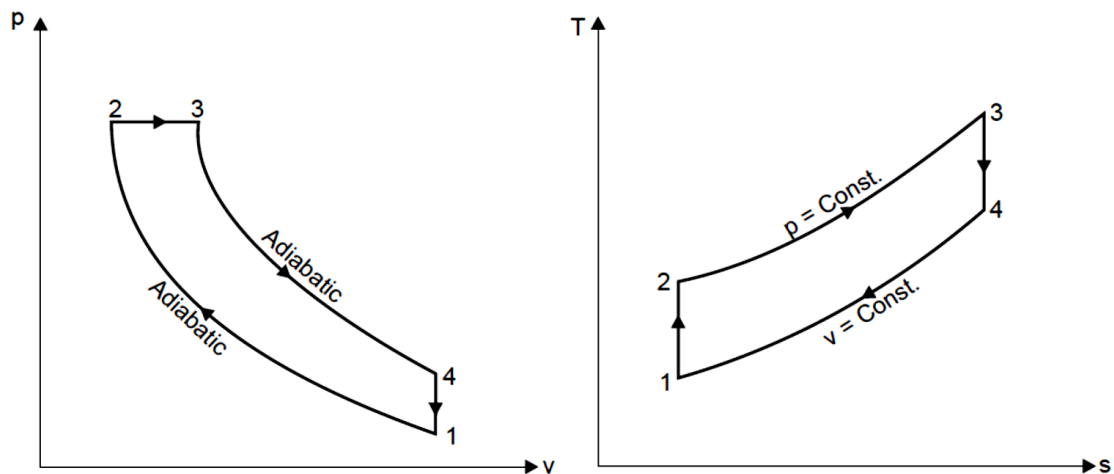

Fig. 1.13 p-V and T-s diagrams of Diesel cycle

#### Adiabatic Compression Process (1 – 2):

- Isentropic (Reversible adiabatic) compression with  $r = \frac{V_1}{V_2}$ .

#### Constant Pressure Heat Addition Process (2 – 3):

- The heat supply is stopped at point 3 which is called the cut – off point and the volume ratio  $\rho = \frac{V_3}{V_2}$  is called **cut off ratio** or Isobaric expansion ratio.

#### Adiabatic Expansion Process (3 – 4):

- Isentropic expansion of air  $\frac{V_4}{V_3} =$  isentropic expansion ratio.

#### Constant Volume Heat Rejection Process (4 – 1):

- In this process heat is rejected at constant volume.
- This thermodynamics cycle is called constant pressure cycle because heat is supplied to the air at constant pressure.

#### Air Standard Efficiency for Diesel Cycle:

- Consider unit mass of air.
- **Heat supplied** during process 2 – 3,

$$q_1 = C_p (T_3 - T_2)$$

- **Heat rejected** during process 4 – 1,

$$q_2 = C_v (T_4 - T_1)$$

- **Work done,**

$$W = q_1 - q_2$$

$$W = C_p(T_3 - T_2) - C_v(T_4 - T_1)$$

– **Thermal efficiency,**

$$\eta = \frac{\text{Work done}}{\text{Heat supplied}}$$

$$\therefore \eta = \frac{C_p(T_3 - T_2) - C_v(T_4 - T_1)}{C_p(T_3 - T_2)}$$

$$\therefore \eta = 1 - \frac{C_v(T_4 - T_1)}{C_p(T_3 - T_2)}$$

$$\therefore \eta = 1 - \frac{1}{\gamma} \frac{(T_4 - T_1)}{(T_3 - T_2)} \quad (1.20)$$

– For adiabatic compression process (1 – 2),

$$r = \frac{V_1}{V_2} \quad (1.21)$$

$$\frac{P_2}{P_1} = \left( \frac{V_1}{V_2} \right)^\gamma$$

$$P_2 = P_1 \cdot r^\gamma \quad (1.22)$$

$$T_2 = T_1 \left( \frac{V_1}{V_2} \right)^{\gamma-1} = T_1 r^{\gamma-1} \quad (1.23)$$

– For constant pressure heat addition process (2 – 3)

$$P_3 = P_2 = P_1 \cdot r^\gamma \quad (1.24)$$

$$\rho = \frac{V_3}{V_2} \quad (\text{Cutoff ratio}) \quad (1.25)$$

$$T_3 = T_2 \frac{V_3}{V_2} \quad (1.26)$$

$$= T_2 \cdot \rho$$

$$\therefore T_3 = T_1 \cdot r^{\gamma-1} \cdot \rho \quad (1.27)$$

– For adiabatic expansion process (3 – 4),

$$P_4 = P_3 (V_3 / V_4)^\gamma = P_3 (V_3 / V_1)^\gamma$$

$$\therefore P_4 = P_3 \left( \frac{V_3 / V_2}{V_1 / V_2} \right)^\gamma = P_3 (\rho / r)^\gamma \quad (1.28)$$

$$T_4 = T_3 \left( \frac{V_3}{V_4} \right)^{\gamma-1} = T_3 \left( \frac{\rho}{r} \right)^{\gamma-1}$$

$$\begin{aligned} \therefore T_4 &= \frac{T_1 \cdot r^{\gamma-1} \cdot \rho \cdot \rho^{\gamma-1}}{r^{\gamma-1}} \\ \therefore T_4 &= T_1 \cdot \rho^\gamma \end{aligned} \quad (1.29)$$

- Using above equations in equation 1.24

$$\begin{aligned} \eta &= 1 - \frac{1}{\gamma} \frac{(T_4 - T_1)}{(T_3 - T_2)} \\ \therefore \eta &= 1 - \frac{1}{\gamma} \frac{(T_1 \rho^\gamma - T_1)}{(T_1 r^{\gamma-1} \rho - T_1 r^{\gamma-1})} \\ \therefore \eta &= 1 - \frac{1}{r^{\gamma-1}} \left[ \frac{(\rho^\gamma - 1)}{\gamma(\rho - 1)} \right] \end{aligned} \quad (1.30)$$

- Apparently the efficiency of diesel cycle depends upon the compression ratio (r) and cutoff ratio (ρ) and hence upon the quantity of heat supplied.
- Fig. 1.14 shows the air standard efficiency of diesel cycle for various cut off ratio.
- Further,

$$K = \frac{\rho^\gamma - 1}{\gamma(\rho - 1)}$$

reveals that with an increase in the cut – off ratio (ρ) the value of factor K increases.

- That implies that for a diesel engine at constant compression ratio, the efficiency would increase with decrease in ρ and in the limit  $\rho \rightarrow 1$ , the efficiency would become

$$1 - \frac{1}{r^{\gamma-1}}$$

- Since the factor  $K = \frac{\rho^\gamma - 1}{\gamma(\rho - 1)}$  is

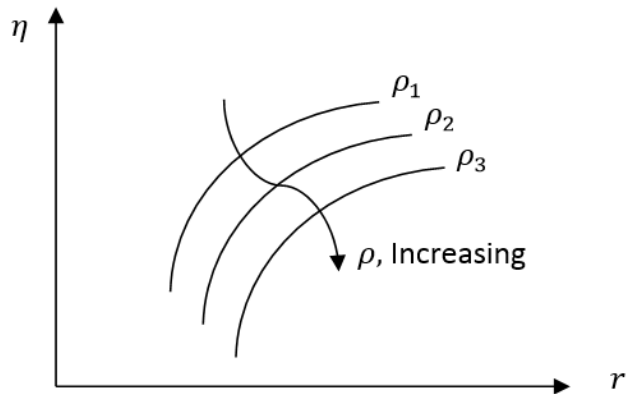

Fig. 1.14 Efficiency of Diesel cycle for various cut-off ratio

- always greater than unity, the Diesel cycle is always less efficient than a corresponding Otto cycle having the same compression ratio.
- However Diesel engine operates on much higher compression ratio (14 to 18) compared to those for S.I. Engines operating on Otto cycle.
- High compression ratios for Diesel engines are must not only for high efficiency but also to prevent diesel knock; a phenomenon which leads to uncontrolled and rapid combustion in diesel engines.

### **Mean Effective Pressure:**

- Net work done per unit mass of air,

$$W_{net} = C_p (T_3 - T_2) - C_v (T_4 - T_1) \quad (1.31)$$

- Swept volume,

$$\begin{aligned} \text{Swept volume} &= V_1 - V_2 = V_1 \left( 1 - \frac{V_2}{V_1} \right) = \frac{RT_1}{P_1} \left( 1 - \frac{1}{r} \right) \\ &= \frac{RT_1}{P_1 r} (r - 1) \end{aligned} \quad (1.32)$$

- Mean effective pressure,

$$\begin{aligned} mep &= \frac{\text{Work done per cycle}}{\text{swept volume}} \\ \therefore mep &= \frac{C_p (T_3 - T_2) - C_v (T_4 - T_1)}{\frac{RT_1}{P_1 r} (r - 1)} \\ \therefore mep &= \frac{C_v}{R} \frac{P_1 r}{(r - 1)} \left[ \frac{\gamma (T_3 - T_2) - (T_4 - T_1)}{T_1} \right] \end{aligned} \quad (1.33)$$

- From equation 1.27, 1.31 and 1.33,

$$T_2 = T_1 r^{\gamma-1}$$

$$T_3 = T_1 r^{\gamma-1} \rho$$

$$T_4 = T_1 \rho^\gamma$$

$$\begin{aligned} \therefore mep &= \frac{C_v}{R} \frac{P_1 r}{(r - 1)} \left[ \frac{\gamma (T_1 r^{\gamma-1} \rho - T_1 r^{\gamma-1}) - (T_1 \rho^\gamma - T_1)}{T_1} \right] \\ \therefore mep &= \frac{P_1 r}{(\gamma - 1)(r - 1)} \left[ \gamma r^{\gamma-1} (\rho - 1) - (\rho^\gamma - 1) \right] \end{aligned} \quad (1.34)$$

### **1.10.3 The Dual Combustion Cycle OR The Limited Pressure Cycle**

- This is a cycle in which the addition of heat is partly at constant volume and partly at constant pressure.

#### **Adiabatic Compression Process (1 – 2):**

- Isentropic (Reversible adiabatic) compression with  $r = \frac{V_1}{V_2}$ .

#### **Constant Volume Heat Addition Process (2 – 3):**

- The heat is supplied at constant volume with explosion ratio or pressure ratio  $\alpha = \frac{P_3}{P_2}$ .

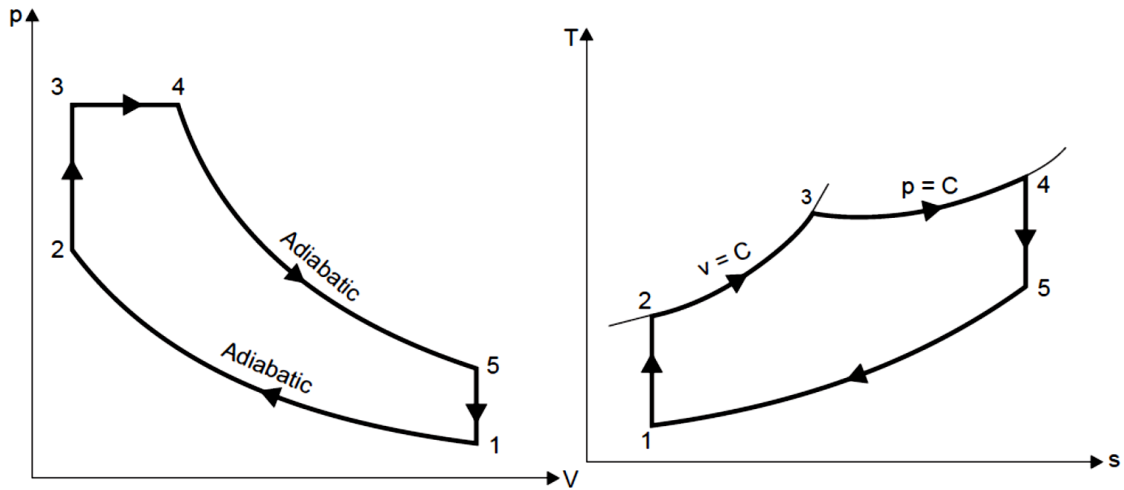

Fig. 1.15 p-V and T-s diagrams of Diesel cycle

**Constant Pressure Heat Addition Process (3 – 4):**

- The heat supply is stopped at point 4 which is called the cut – off point and the volume ratio  $\rho = \frac{V_4}{V_3}$  is called **cut off ratio**.

**Adiabatic Expansion Process (4 – 5):**

- Isentropic expansion of air with  $\frac{V_5}{V_4} =$  isentropic expansion ratio.

**Constant Volume Heat Rejection Process (5 – 1):**

- In this process heat is rejected at constant volume.
- The high speed Diesel engines work on a cycle which is slight modification of the Dual cycle.

**Thermal Efficiency for Dual Cycle:**

- Consider unit mass of air undergoing the cyclic change.
- **Heat supplied,**

$$q_1 = q_{2-3} + q_{3-4}$$

$$q_1 = C_V (T_3 - T_2) + C_P (T_4 - T_3)$$

- **Heat rejected** during process 5 – 1,

$$q_2 = C_V (T_5 - T_1)$$

- **Work done,**

$$W = q_1 - q_2$$

$$W = C_V (T_3 - T_2) + C_P (T_4 - T_3) - C_V (T_5 - T_1)$$

- **Thermal efficiency,**

$$\eta = \frac{\text{Work done}}{\text{Heat supplied}}$$

$$\therefore \eta = \frac{C_V(T_3 - T_2) + C_P(T_4 - T_3) - C_V(T_5 - T_1)}{C_V(T_3 - T_2) + C_P(T_4 - T_3)}$$

$$\therefore \eta = 1 - \frac{(T_5 - T_1)}{(T_3 - T_2) + \gamma(T_4 - T_3)} \quad (1.35)$$

- For adiabatic compression process (1 – 2),

$$r = \frac{V_1}{V_2} \quad (1.36)$$

$$\frac{P_2}{P_1} = \left( \frac{V_1}{V_2} \right)^\gamma$$

$$P_2 = P_1 r^\gamma \quad (1.37)$$

$$T_2 = T_1 \left( \frac{V_1}{V_2} \right)^{\gamma-1} = T_1 r^{\gamma-1} \quad (1.38)$$

- For constant volume heat addition process (2 – 3)

$$V_3 = V_2 = \frac{V_1}{r}$$

$$\alpha = \frac{P_3}{P_2} \quad (\text{Pressure ratio}) \quad (1.39)$$

$$\therefore P_3 = P_2 \cdot \alpha = P_1 \cdot r^\gamma \cdot \alpha$$

$$T_3 = T_2 \frac{P_3}{P_2}$$

$$= T_2 \alpha$$

$$\therefore T_3 = T_1 r^{\gamma-1} \alpha \quad (1.40)$$

- For constant pressure heat addition process (3 – 4)

$$P_3 = P_4 = P_1 r^\gamma \alpha \quad (1.41)$$

$$\rho = \frac{V_4}{V_3} \quad (\text{Cutoff ratio}) \quad (1.42)$$

$$T_4 = T_3 \frac{V_4}{V_3}$$

$$\therefore T_4 = T_3 \rho$$

$$\therefore T_4 = T_1 r^{\gamma-1} \rho \alpha \quad (1.43)$$

- For adiabatic expansion process (4 – 5),

$$P_4 V_4^\gamma = P_5 V_5^\gamma$$

$$\begin{aligned}
P_5 &= P_4 (V_4 / V_5)^\gamma = P_3 (V_4 / V_1)^\gamma \quad (\because \quad \&P_3 = P_4) \\
P_5 &= P_3 \left( \frac{V_4 V_3}{V_1 V_3} \right)^\gamma = P_3 \left( \frac{V_4 V_2}{V_1 V_3} \right)^\gamma \quad (\because \quad | \\
\therefore P_5 &= P_3 \left( \frac{V_4 / V_3}{V_1 / V_2} \right)^\gamma = P_3 (\rho / r)^\gamma \text{-----}(i) \quad (1.44)
\end{aligned}$$

and

$$\begin{aligned}
T_5 &= T_4 \left( \frac{V_4}{V_5} \right)^{\gamma-1} \\
\therefore T_5 &= T_4 \left( \frac{\rho}{r} \right)^{\gamma-1} \\
\therefore T_5 &= \frac{T_1 r^{\gamma-1} \rho \alpha \rho^{\gamma-1}}{r^{\gamma-1}} \\
\therefore T_5 &= T_1 \alpha \rho^\gamma \quad (1.45)
\end{aligned}$$

– From equation 1.39,

$$\begin{aligned}
\eta &= 1 - \frac{(T_5 - T_1)}{(T_3 - T_2) + \gamma(T_4 - T_3)} \\
\therefore \eta &= 1 - \frac{(T_1 \alpha \rho^\gamma - T_1)}{(T_1 r^{\gamma-1} \alpha - T_1 r^{\gamma-1}) + \gamma(T_1 r^{\gamma-1} \alpha \rho - T_1 r^{\gamma-1} \alpha)} \\
\therefore \eta &= 1 - \frac{(\rho^\gamma \alpha - 1)}{\left[ r^{\gamma-1} \{(\alpha - 1\alpha) + \gamma\alpha(\rho - 1)\} \right]} \\
\therefore \eta &= 1 - \frac{1}{r^{\gamma-1}} \left[ \frac{(\alpha \rho^\gamma - 1)}{(\alpha - 1) + \gamma\alpha(\rho - 1)} \right] \quad (1.46)
\end{aligned}$$

- It can be seen from the equation 1.50 that the thermal efficiency of a Dual cycle can be increased by supplying a greater portion of heat at constant volume (high value of  $\alpha$ ) and smaller portion at constant pressure (low value of  $\rho$ ).
- In the actual high speed Diesel engines operating on this cycle, it is achieved by early fuel injection and an early cut-off.
- It is to be noted that Otto and Diesel cycles are special cases of the Dual cycle.
- If  $\rho = 1$  ( $V_3 = V_4$ )
- Hence, there is no addition of heat at constant pressure. Consequently the entire heat is supplied at constant volume and the cycle becomes the Otto cycle.
- By substituting  $\rho = 1$  in equation 1.50, we get,

$$\eta = 1 - \frac{1}{r^{(\gamma-1)}} = \text{Efficiency of Otto cycle}$$

- Similarly if  $\alpha = 1$ , the heat addition is only at constant pressure and cycle becomes Diesel cycle.

- By substituting  $\alpha = 1$  in equation 1.50, we get,

$$\eta = 1 - \frac{1}{r^{\gamma-1}} \left[ \frac{(\rho^\gamma - 1)}{\gamma(\rho - 1)} \right] = \text{Efficiency of Diesel cycle}$$

- **Mean Effective Pressure:**

- **Net work done** per unit mass of air,

$$W_{net} = C_V (T_3 - T_2) + C_p (T_4 - T_3) - C_V (T_5 - T_1) \quad (1.47)$$

- **Swept volume,**

$$\begin{aligned} \text{Swept Volume} = V_1 - V_2 &= V_1 \left( 1 - \frac{V_2}{V_1} \right) = \frac{RT_1}{P_1} \left( 1 - \frac{1}{r} \right) \\ &= \frac{RT_1}{P_1 r} (r - 1) \end{aligned} \quad (1.48)$$

- **Mean effective pressure,**

$$mep = \frac{\text{Work done per cycle}}{\text{swept volume}}$$

$$\therefore mep = \frac{C_V (T_3 - T_2) + C_p (T_4 - T_3) - C_V (T_5 - T_1)}{\frac{RT_1}{P_1 r} (r - 1)}$$

$$\therefore mep = \frac{C_V}{R} \frac{P_1 r}{(r - 1)} \left[ \frac{(T_3 - T_2) + \gamma (T_4 - T_3) - (T_5 - T_1)}{T_1} \right]$$

- From equation 1.42, 1.44, 1.47 and 1.49,

$$T_2 = T_1 \cdot r^{\gamma-1}$$

$$T_3 = T_1 \cdot r^{\gamma-1} \cdot \alpha$$

$$T_4 = T_1 \cdot r^{\gamma-1} \cdot \alpha \cdot \rho$$

$$T_5 = T_1 \cdot \alpha \cdot \rho^\gamma$$

$$\therefore mep = \frac{C_V}{R} \frac{P_1 r}{(r - 1)} \left[ \frac{\gamma (T_1 r^{\gamma-1} \alpha - T_1 r^{\gamma-1}) + \gamma (T_1 r^{\gamma-1} \alpha \rho - T_1 r^{\gamma-1} \alpha) - (T_1 \alpha \rho^\gamma - T_1)}{T_1} \right]$$

$$\therefore mep = \frac{P_1 r}{(\gamma - 1)(r - 1)} \left[ (\alpha - 1) r^{\gamma-1} + \gamma \alpha r^{\gamma-1} (\rho - 1) - (\alpha \rho^\gamma - 1) \right] \quad (1.49)$$

# 2

## FUEL AIR CYCLES & ACTUAL AIR CYCLES

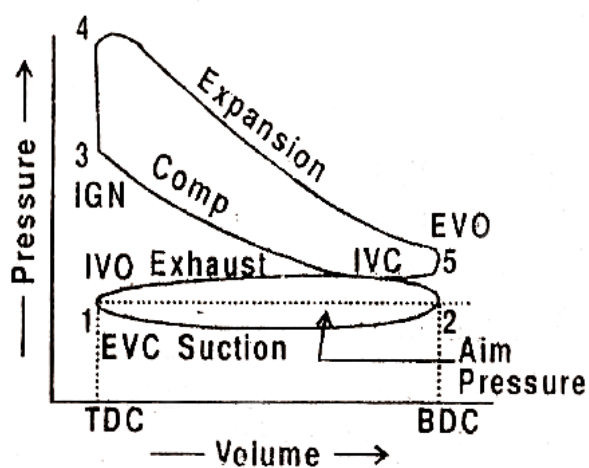
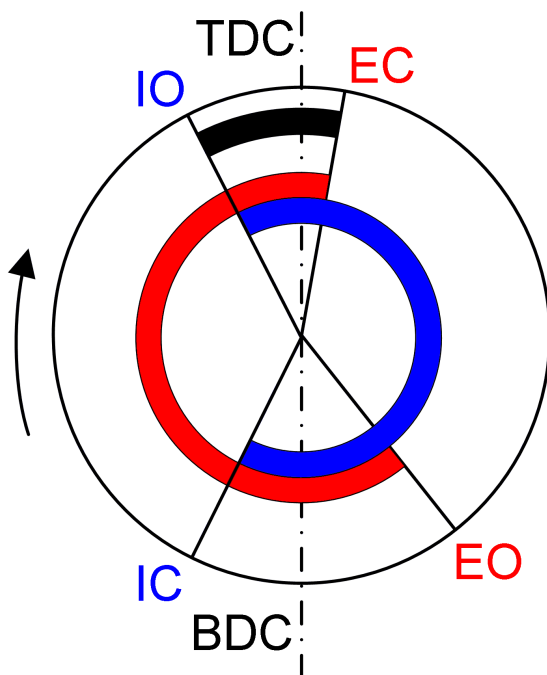

Indicator Diagram For A Four Stroke Cycle Petrol Engine.

### Course Contents

- 2.1 Fuel-Air cycle
- 2.2 Variable specific heat
- 2.3 Change of internal energy and enthalpy during a process with variable specific heats
- 2.4 Isentropic expansion with variable specific heats
- 2.5 Effect of variable specific heats on air standard efficiency of Otto and Diesel cycle
- 2.6 Dissociation
- 2.7 Effect of operating variables
- 2.8 Comparison of air standard and actual cycle
- 2.9 Deviation of actual cycle from fuel air cycle
- 2.10 Valve and Port timing diagram

## 2.1 Fuel-Air cycle

### 2.1.1 Introduction

- The air cycle approximation of air standard theory has highly simplified assumptions. The air standard theory gives an estimate of engine performance which is much greater than the actual performance. For example the actual indicated thermal efficiency of a petrol engine of, say compression ratio 7:1, is of the order of 30% whereas the air standard efficiency is of the order of 54%.
- This large divergence is partly due to non-instantaneous burning and valve operation, incomplete combustion, etc. But the main reason of divergence is the oversimplification in using the values of the properties of the working fluid for cycle analysis.
- In the air cycle analysis it was assumed that the working fluid is nothing but air and this air was a perfect gas and had constant specific heats.
- In actual engine the working fluid is not air but a mixture of air, fuel and residual gases. Furthermore, the specific heats of the working fluid are not constant but increase as temperature rises, and finally, the products of combustion are subjected to dissociation at high temperature.

### 2.1.2 Factors considered for Fuel-Air cycle calculations

The following factors are taken into consideration while making fuel-air cycle calculations:

- **The actual composition of the cylinder gases:** The cylinder gases contain fuel, air, water vapour and residual gas. The fuel-air ratio changes during the operation of the engine which changes the relative amounts of CO<sub>2</sub>, water vapour, etc.
- **The variation in the specific heat with temperature:** Specific heats increase with temperature except for mono-atomic gases. Therefore, the value of  $\gamma$  also changes with temperature.
- **The effect of dissociation:** The fuel and air do not completely combine chemically at high temperatures (above 1600 K) and this leads to the presence of CO, H<sub>2</sub>, H and O<sub>2</sub> at equilibrium conditions.
- **The variation in the number of molecules:** The number of molecules present after combustion depends upon fuel-air ratio and upon the pressure and temperature after the combustion.

### 2.1.3 Assumptions made for Fuel-Air cycle analysis

- There is no chemical change in either fuel or air prior to combustion.
- Subsequent to combustion, the charge is always in chemical equilibrium.
- There is no heat exchange between the gases and the cylinder walls in any process, i.e. they are adiabatic. Also the compression and expansion processes are frictionless.
- In case of reciprocating engines it is assumed that fluid motion can be ignored inside the cylinder.
- With particular reference to constant-volume fuel-air cycle, it is also assumed that

- The fuel is completely vaporized and perfectly mixed with the air, and
- The burning takes place instantaneously at top dead centre (at constant volume).

### 2.1.4 Importance of Fuel-Air cycle

- The air-standard cycle analysis shows the general effect of only compression ratio on engine efficiency whereas the fuel-air cycle analysis gives the effect of variation of fuel-air ratio, inlet pressure and temperature on the engine performance. It will be noticed that compression ratio and fuel-air ratio are very important parameters of the engine while inlet conditions are not so important.
- The actual efficiency of a good engine is about 85 per cent of the estimated fuel-air cycle efficiency. A good estimate of the power to be expected from the actual engine can be made from fuel-air cycle analysis. Also, peak pressures and exhaust temperatures which affect the engine structure and design can be estimated reasonably close to an actual engine. Thus the effect of many variables on the performance of an engine can be understood better by fuel-air cycle analysis.

## 2.2 Variable Specific Heats

- All gases, except mono-atomic gases, show an increase in specific heat with temperature. The increase in specific heat does not follow any particular law. However, over the temperature range generally encountered for gases in heat engines (300 K to 2000 K) the specific heat curve is nearly a straight line which may be approximately expressed in the form

$$\begin{aligned} C_p &= a_1 + K_1 T \\ C_v &= b_1 + K_1 T \end{aligned} \quad (2.1)$$

where  $a_1, b_1$  and  $K_1$  are constants. Now,

$$R = C_p - C_v = a_1 - b_1 \quad (2.2)$$

where  $R$  is the characteristic gas constant.

- Above 1500 K the specific heat increases much more rapidly and may be expressed in the form

$$C_p = a_1 + K_1 T + K_2 T^2 \quad (2.3)$$

$$C_v = b_1 + K_1 T + K_2 T^2 \quad (2.4)$$

- In above equations if the term  $T^2$  is neglected it becomes same as Eqn.2.1. Many expressions are available even upto sixth order of  $T$  (i.e.  $T^6$ ) for the calculation of  $C_p$  and  $C_v$ .
- The physical explanation for increase in specific heat is that as the temperature is raised, larger fractions of the heat would be required to produce motion of the atoms within the molecules. Since temperature is the result of motion of the molecules, as a whole, the energy which goes into moving the atoms does not contribute to proportional temperature rise. Hence, more heat is required to raise the temperature

of unit mass through one degree at higher levels. This heat by definition is the specific heat. The values for  $C_p$  and  $C_v$  for air are usually taken as

$$C_p = 1.005 \text{ kJ/kg K}, \quad C_v = 0.717 \text{ kJ/kg K} \quad \text{at 300 K}$$

$$C_p = 1.345 \text{ kJ/kg K}, \quad C_v = 1.057 \text{ kJ/kg K} \quad \text{at 2000 K}$$

- Since the difference between  $C_p$  and  $C_v$  is constant, the value of  $\gamma$  decreases with increase in temperature. Thus, if the variation of specific heats is taken into account during the compression stroke, the final temperature and pressure would be lower than if constant values of specific heat are used. This point is illustrated in Fig.2.1.

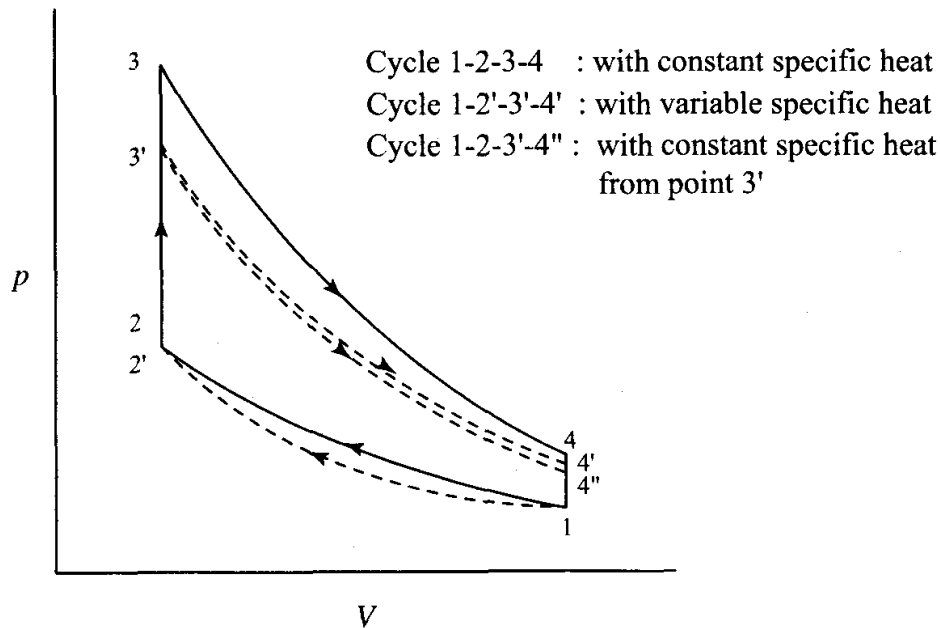

Fig. 2.1 Loss of power due to variation of specific heat

- With variable specific heats, the temperature at the end of compression will be  $2'$ , instead of  $2$ . The magnitude of drop in temperature is proportional to the drop in the value of ratio of specific heats. For the process  $1 \rightarrow 2$ , with constant specific heats

$$T_2 = T_1 \left( \frac{v_1}{v_2} \right)^{\gamma-1} \quad (2.5)$$

with variable specific heats,

$$T_{2'} = T_1 \left( \frac{v_1}{v_{2'}} \right)^{k-1} \quad (2.6)$$

where  $k = \frac{C_p}{C_v}$ . Note that  $v_{2'} = v_2$  and  $v_1/v_2 = v_1/v_{2'} = r$ .

- For given values of  $T_1$ ,  $p_1$  and  $r$ , the magnitude of  $T_2$  depends on  $k$ . Constant volume combustion, from point  $2'$  will give a temperature  $T_{3'}$  instead of  $T_3$ . This is due to the fact that the rise in the value of  $C_v$  because of variable specific heat, which reduces the temperature as already explained.
- The process,  $2'-3'$  is heat addition with the variation in specific heat. From  $3'$ , if expansion takes place at constant specific heats, this would result in the process  $3'-4''$

whereas actual expansion due to variable specific heat will result in 3'-4' and 4' is higher than 4". The magnitude in the difference between 4' and 4" is proportional to the reduction in the value of  $\gamma$ .

- Consider the process 3'-4"

$$T_{4''} = T_{3'} \left( \frac{v_3}{v_4} \right)^{k-1} \quad (2.7)$$

For the process 3'-4'

$$T_{4'} = T_{3'} \left( \frac{v_3}{v_4} \right)^{\gamma-1} \quad (2.8)$$

- Reduction in the value of  $k$  due to variable specific heat results in increase of temperature from  $T_{4''}$  to  $T_{4'}$ .

## 2.3 Change of Internal energy and enthalpy during a process with variable specific heats

### 2.3.1 Change of Internal energy

- The small change in internal energy of a unit mass of a gas for small change in temperature ( $dT$ ) is given by:

$$du = C_v dT$$

$$\begin{aligned} \therefore u_2 - u_1 &= \int_{T_1}^{T_2} C_v dT \\ &= \int_{T_1}^{T_2} (b + KT) dT \\ &= \left[ bT + K \frac{T^2}{2} \right]_{T_1}^{T_2} = b(T_2 - T_1) + \frac{K}{2}(T_2^2 - T_1^2) \\ &= (T_2 - T_1) \left[ b + K \frac{(T_2 + T_1)}{2} \right] \\ &= (T_2 - T_1)(b + KT_m) \quad \text{where, } T_m = \frac{T_1 + T_2}{2} \end{aligned}$$

$$C_{vm} = b + KT_m \quad (C_{vm} \text{ mean specific heat at constant volume})$$

$$\therefore u_2 - u_1 = C_{vm}(T_2 - T_1) \quad (2.9)$$

### 2.3.2 Change of Enthalpy

- The small change in enthalpy of a unit mass of a gas for small change in temperature ( $dT$ ) is given by:

$$dh = C_p dT$$

$$\begin{aligned}
\therefore h_2 - h_1 &= \int_{T_1}^{T_2} C_p dT \\
&= \int_{T_1}^{T_2} (a + KT) dT \\
&= \left[ aT + K \frac{T^2}{2} \right]_{T_1}^{T_2} = a(T_2 - T_1) + \frac{K}{2}(T_2^2 - T_1^2) \\
&= (T_2 - T_1) \left[ a + K \frac{(T_2 + T_1)}{2} \right] \\
&= (T_2 - T_1)(a + KT_m) \quad \text{where, } T_m = \frac{T_1 + T_2}{2}
\end{aligned}$$

$$C_{pm} = a + KT_m \quad (C_{pm} \text{ mean specific heat at constant pressure})$$

$$\therefore h_2 - h_1 = C_{pm} (T_2 - T_1) \quad (2.10)$$

## 2.4 Isentropic expansion with variable specific heats

- Consider one kg of air, the heat transfer to a system using first law can be written as

$$dQ = du + dW$$

$$dQ = C_v dT + p dv$$

- For isentropic process,  $dQ = 0$

$$\therefore C_v dT + p dv = 0$$

$$\therefore C_v \frac{dT}{T} + \frac{p}{T} dv = 0$$

$$\therefore C_v \frac{dT}{T} + R \frac{dv}{v} = 0 \quad (\because pv = RT)$$

- Putting the values of  $R$  and  $C_v$  in the above equation, we get

$$\therefore (b + KT) \frac{dT}{T} + (a - b) \frac{dv}{v} = 0$$

- Integrating both sides we get

$$\therefore \int (b + KT) \frac{dT}{T} + \int (a - b) \frac{dv}{v} = \text{constant}$$

$$\therefore \int b \frac{dT}{T} + K \int dT + (a - b) \int \frac{dv}{v} = \text{constant}$$

$$\therefore b \log_e T + KT + (a - b) \log_e v = \text{constant}$$

$$\therefore \log_e T^b + \log_e e^{KT} + \log_e v^{(a-b)} = \text{constant}$$

$$\therefore T^b e^{KT} v^{(a-b)} = \text{constant}$$

$$\therefore T e^{\frac{K}{b} T} v^{\frac{(a-b)}{b}} = \text{constant} \quad (2.11)$$

$$\therefore \frac{T}{v} e^{\frac{K}{b} T} v^{\frac{a}{b}} = \text{constant} \quad (2.12)$$

$$pv = RT \Rightarrow \frac{T}{v} = \frac{p}{R} = \frac{p}{a-b}$$

- Inserting the value of above equation in eq. 2.13.

$$\begin{aligned}\therefore \frac{p}{a-b} e^{\frac{KT}{b}} v^{\frac{a}{b}} &= \text{constant} \\ \therefore p v^{\frac{a}{b}} e^{\frac{KT}{b}} &= \text{constant}\end{aligned}\quad (2.13)$$

## 2.5 Effect of variable specific heats on air standard efficiency of Otto and diesel cycle

### 2.5.1 Otto cycle

- The air standard efficiency of Otto cycle is given by

$$\begin{aligned}\eta &= 1 - \frac{1}{r^{\gamma-1}} \\ \text{Now, } C_p - C_v &= R \\ \therefore \frac{C_p}{C_v} - 1 &= \frac{R}{C_v} \\ \therefore \gamma - 1 &= \frac{R}{C_v} \quad \left( \because \begin{matrix} \gamma \\ \gamma_v \end{matrix} \right)\end{aligned}\quad (2.14)$$

$$\begin{aligned}\eta &= 1 - \frac{1}{r^{\frac{R}{C_v}}} = 1 - r^{-\frac{R}{C_v}} \\ \therefore 1 - \eta &= (r)^{-\frac{R}{C_v}}\end{aligned}$$

- Taking log on both sides, we have

$$\therefore \log_e (1 - \eta) = -\frac{R}{C_v} \log_e (r)$$

- Differentiating the above equation, we have

$$\begin{aligned}\therefore -\frac{1}{1-\eta} \frac{d\eta}{dC_v} &= -R \log_e r \left( -\frac{1}{C_v^2} \right) \\ \therefore \frac{d\eta}{1-\eta} &= -\frac{R}{C_v} \cdot \log_e r \cdot \frac{dC_v}{C_v} \\ \therefore \frac{d\eta}{\eta} &= -\frac{1-\eta}{\eta} \cdot (\gamma-1) \cdot \log_e r \cdot \frac{dC_v}{C_v}\end{aligned}\quad (2.15)$$

- Negative sign indicates the decrease in efficiency with increase in  $C_v$ .
- The Eq. 2.15 gives the percentage variation in air standard efficiency of Otto cycle on account of percentage variation in  $C_v$ .

### 2.5.2 Diesel Cycle

- The air standard efficiency of diesel cycle is given by

$$\eta = 1 - \frac{1}{(r)^{\gamma-1}} \left[ \frac{\rho^\gamma - 1}{\gamma(\rho - 1)} \right]$$

$$\therefore 1 - \eta = \frac{1}{(r)^{\gamma-1}} \left[ \frac{\rho^\gamma - 1}{\gamma(\rho - 1)} \right]$$

- Taking log on both sides, we get

$$\therefore \log(1 - \eta) = \log(\rho^\gamma - 1) - \log(r)^{\gamma-1} - \log \gamma - \log(\rho - 1)$$

$$\therefore \log(1 - \eta) = \log(\rho^\gamma - 1) - (\gamma - 1) \log r - \log \gamma - \log(\rho - 1)$$

- Differentiating the above equation with respect to  $\gamma$

$$\therefore -\frac{1}{1 - \eta} \cdot \frac{d\eta}{d\gamma} = \frac{1}{\rho^\gamma - 1} \cdot \rho^\gamma \log_e \rho - \log_e r - \frac{1}{\gamma}$$

$$\therefore \frac{d\eta}{d\gamma} = (1 - \eta) \left[ \log_e r - \frac{\rho^\gamma \log_e \rho}{\rho^\gamma - 1} + \frac{1}{\gamma} \right]$$

- Multiplying the above equation by  $\frac{d\gamma}{\eta}$

$$\therefore \frac{d\eta}{\eta} = \left( \frac{1 - \eta}{\eta} \right) \left[ \log_e r - \frac{\rho^\gamma \log_e \rho}{\rho^\gamma - 1} + \frac{1}{\gamma} \right] \cdot d\gamma \quad (2.16)$$

- Eq. 2.14 is  $\gamma - 1 = \frac{R}{C_v}$ , differentiating this equation with respect to  $C_v$

$$\therefore \frac{d\gamma}{dC_v} = -\frac{R}{C_v^2} \Rightarrow d\gamma = -\frac{R}{C_v} \cdot \frac{dC_v}{C_v}$$

$$d\gamma = -(\gamma - 1) \cdot \frac{dC_v}{C_v} \quad (2.17)$$

- Inserting the value of Eq. 2.17 into Eq. 2.16, we get

$$\therefore \frac{d\eta}{\eta} = -\frac{1 - \eta}{\eta} \cdot (\gamma - 1) \left[ \log_e r - \frac{\rho^\gamma \log_e \rho}{\rho^\gamma - 1} + \frac{1}{\gamma} \right] \cdot \frac{dC_v}{C_v} \quad (2.18)$$

## 2.6 Dissociation

- Dissociation process can be considered as the disintegration of combustion products at high temperature.
- Dissociation can also be looked as the reverse process to combustion. During dissociation the heat is absorbed whereas during combustion the heat is liberated.
- In IC engines, mainly dissociation of  $\text{CO}_2$  into  $\text{CO}$  and  $\text{O}_2$  occurs, whereas there is a very little dissociation of  $\text{H}_2\text{O}$ .
- The dissociation of  $\text{CO}_2$  into  $\text{CO}$  and  $\text{O}_2$  starts commencing around  $1000^\circ\text{C}$  and the reaction equation can be written as

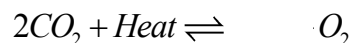

- Similarly, the dissociation of  $H_2O$  occurs at temperatures above  $1300\text{ }^\circ\text{C}$  and written as

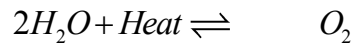

- The presence of  $CO$  and  $O_2$  in the gases tends to prevent dissociation of  $CO_2$ ; this is noticeable in a rich fuel mixture, which, by producing more  $CO$ , suppresses dissociation of  $CO_2$ .
- On the other hand, there is no dissociation in burnt gases of a lean fuel-air mixture. This is mainly due to the fact that temperature produced is too low for this phenomenon to occur.
- Hence, the maximum extent of dissociation occurs in the burnt gases of the chemically correct fuel-air mixture when the temperatures are expected to be high but decreases with the leaner and richer mixtures.
- In case of internal combustion engines heat transfer to the cooling medium causes a reduction in the maximum temperature and pressure. As the temperature falls during the expansion stroke the separated constituents recombine; the heat absorbed during dissociation is thus again released, but it is too late in the stroke to recover entirely the lost power. A portion of this heat is carried away by the exhaust gases.

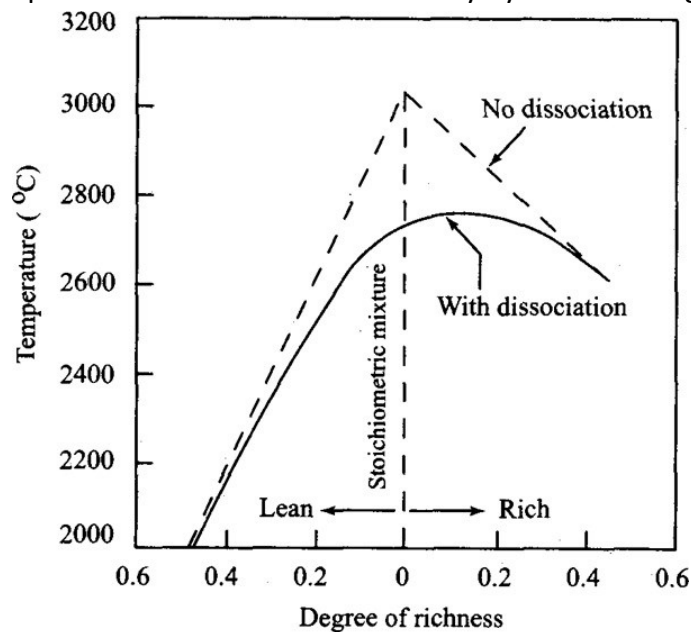

Fig. 2.2 Effect of dissociation on temperature

- Figure 2.2 shows a typical curve that indicates the reduction in the temperature of the exhaust gas mixtures due to dissociation with respect to air-fuel ratio. With no dissociation maximum temperature is attained at chemically correct air-fuel ratio.
- With dissociation maximum temperature is obtained when mixture is slightly rich. Dissociation reduces the maximum temperature by about  $300\text{ }^\circ\text{C}$  even at the chemically correct air-fuel ratio. In the Fig. 2.2, lean mixtures and rich mixtures are marked clearly.

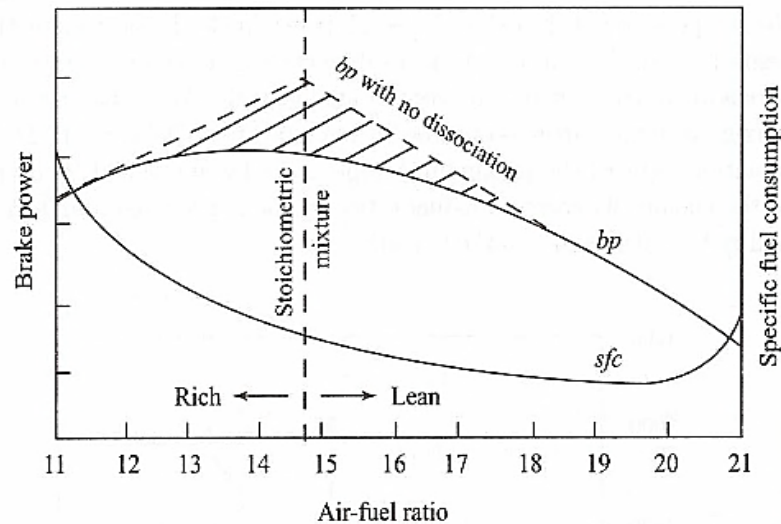

Fig. 2.3 Effect of dissociation on power

- The effect of dissociation on output power is shown in Fig.2.3 for a typical four-stroke spark-ignition engine operating at constant speed. If there is no dissociation the brake power output is maximum when the mixture ratio is stoichiometric.
- The shaded area between the brake power graphs shows the loss of power due to dissociation. When the mixture is quite lean there is no dissociation. As the air-fuel ratio decreases i.e., as the mixture becomes rich the maximum temperature raises and dissociation commences.
- The maximum dissociation occurs at chemically correct mixture strength. As the mixture becomes richer, dissociation effect tends to decline due to incomplete combustion.
- Dissociation effects are not so pronounced in a CI engine as in an SI engine. This is mainly due to
  - (i) the presence of a heterogeneous mixture and
  - (ii) excess air to ensure complete combustion.

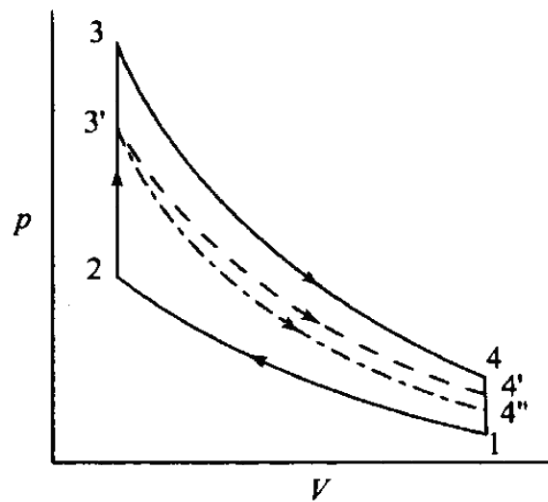

Fig. 2.4 Effect of dissociation shown on a p-V diagram

- Both these factors tend to reduce the peak gas temperature attained in the CI engine.
- Figure 2.4 shows the effect of dissociation on p-V diagram of Otto cycle. Because of lower maximum temperature due to dissociation the maximum pressure is also reduced and the state after combustion will be represented by 3' instead of 3. If there was no reassociation due to fall of temperature during expansion the expansion

process would be represented by  $3'-4''$  but due to reassociation the expansion follows the path  $3'-4'$ .

- By comparing with the ideal expansion  $3-4$ , it is observed that the effect of dissociation is to lower the temperature and consequently the pressure at the beginning of the expansion stroke. This causes a loss of power and also efficiency. Though during recombining the heat is given back it is too late to contribute a convincing positive increase in the output of the engine.

## 2.7 Effect of operating variables

The effect of common engine operating variables on the pressure and temperature within the engine cylinder is better understood by fuel-air cycle analysis. The details are discussed in this section:

### 2.7.1 Compression Ratio

- The fuel-air cycle efficiency increases with the compression ratio in the same manner as the air-standard cycle efficiency, principally for the same reason (more scope of expansion work. This is shown in fig 2.5.

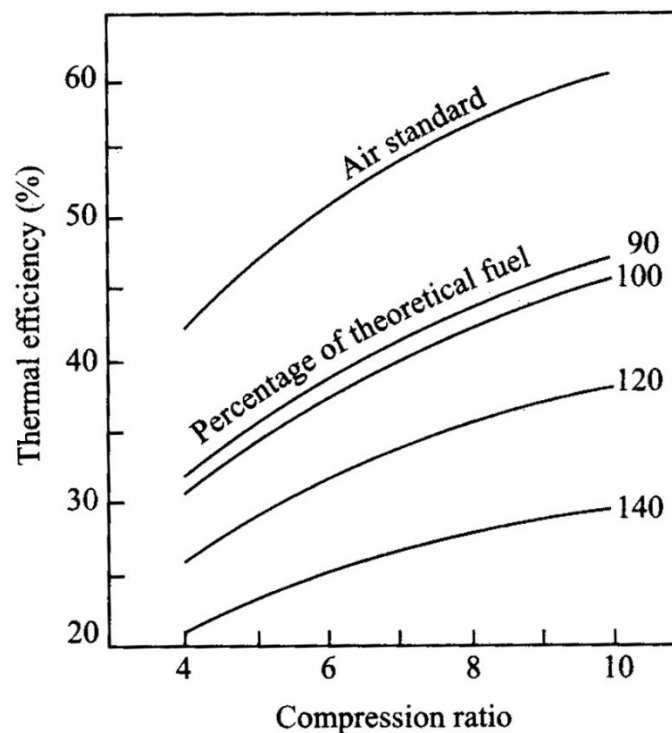

Fig. 2.5 Effect of compression ratio and mixture strength on efficiency

- The variation of indicated thermal efficiency with respect to the equivalence ratio for various compression ratios is given in fig 2.6. The equivalence ratio,  $\phi$ , is defined as ratio of actual fuel-air ratio to chemically correct fuel-air ratio on mass basis.

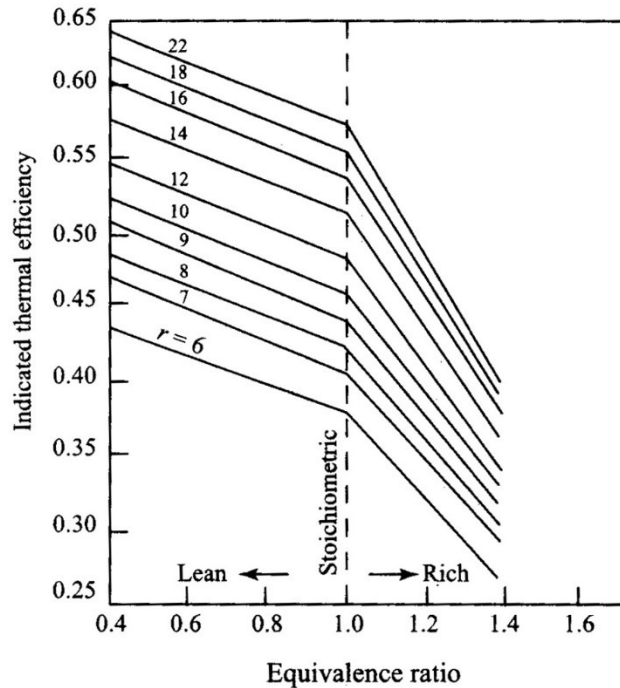

Fig. 2.6 Effect of mixture strength on thermal efficiency for various compression ratios

- The maximum pressure and temperature increase with compression ratio since the temperature,  $T_2$ , and pressure,  $p_2$ , at the end of compression are higher. However, it can be noted from the experimental results that the ratio of fuel-air cycle efficiency to air-standard efficiency is independent of the compression ratio for given equivalence ratio for the constant volume fuel-air cycle.

## 2.7.2 Fuel Air ratio

### a) Efficiency

- As the mixture is made lean (less fuel) the temperature rise due to combustion will be lowered as a result of reduced energy input per unit mass of mixture. This will result in lower specific heat.
- Further, it will lower the losses due to dissociation and variation in specific heat. The efficiency is therefore, higher and, in fact, approaches the air-cycle efficiency as the fuel-air ratio is reduced as shown in Fig. 2.7.

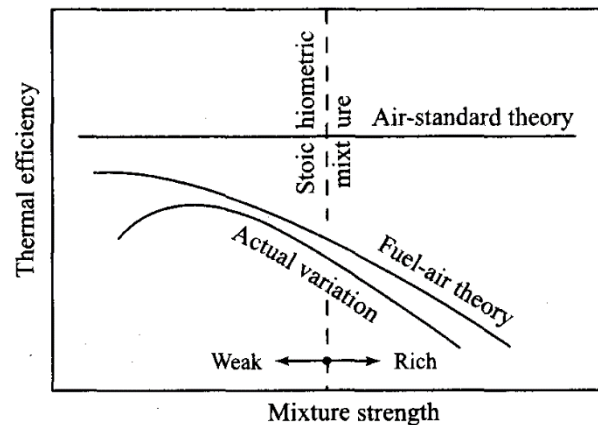

Fig. 2.7 Effect of mixture strength on thermal efficiency

### b) Maximum Power

- Fig. 2.8 gives the cycle power as affected by fuel-air ratio. By air-standard theory maximum power is at chemically correct mixture, but by fuel-air theory maximum

power is when the mixture is about 10% rich. As the mixture becomes richer the efficiency falls rapidly.

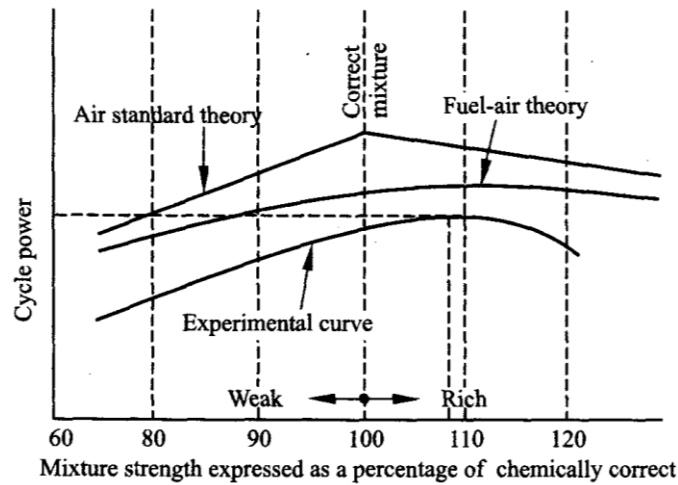

Fig. 2.8 Effect of fuel-air ratio on power

- This is because in addition to higher specific heats and chemical equilibrium losses, there is insufficient air which will result in formation of CO and H<sub>2</sub> in combustibles, which represents a direct wastage of fuel.

**c) Maximum temperature**

- At a given compression ratio the temperature after combustion reaches a maximum when the mixture is slightly rich, i.e., around 6 % or so ( $F/A = 0.072$  or  $A/F = 14:1$ ) as shown in Fig. 2.9.
- At chemically correct ratio there is still some oxygen present at the point 3 because of chemical equilibrium effects a rich mixture will cause more fuel to combine with oxygen at that point thereby raising the temperature  $T_3$ . However, at richer mixtures increased formation of CO counters this effect.

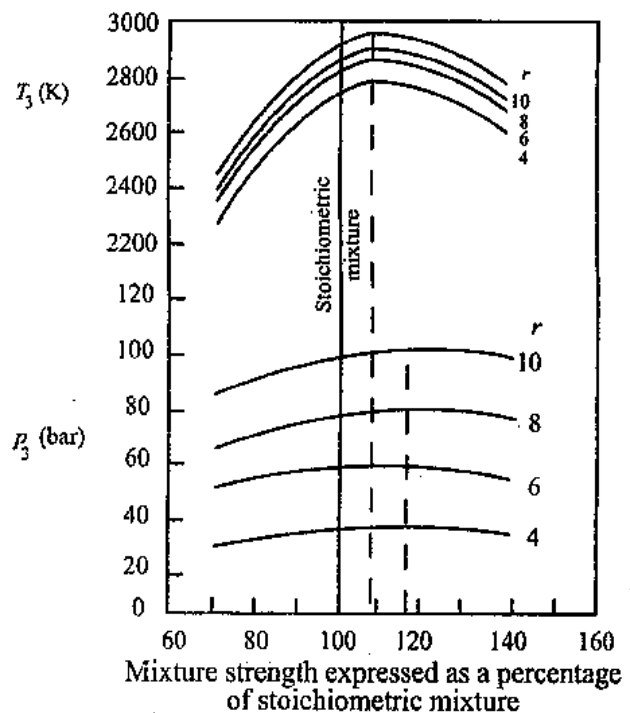

Fig. 2.9 Effect of equivalence ratio on  $T_3$  and  $p_3$

**d) Maximum Pressure**

- The pressure of a gas in a given space depends upon its temperature and the number of molecules. The curve of  $p_3$ , therefore follows  $T_3$ , but because of the increasing number of molecules  $p_3$  does not start to decrease until the mixture is somewhat richer than that for maximum  $T_3$  (at  $F/A = 0.083$  or  $A/F = 12:1$ ), i.e. about 20 per cent rich (Fig.2.9).

### e) Exhaust Temperature

- The exhaust gas temperature,  $T_4$  is maximum at the chemically correct mixture as shown in Fig. 2.10. At this point there is reassociation as the temperature decrease so heat will be released these heat cannot be used in engine cylinder so the exhaust gases carry these heat with them and it result in higher exhaust temperature.
- At lean mixtures, because of less fuel,  $T_3$  is less and hence  $T_4$  is less. At rich mixtures less sensible energy is developed and hence  $T_4$  is less. That is,  $T_4$  varies with fuel-air ratio in the same manner as  $T_3$  except that maximum  $T_4$  is at the chemically correct fuel-air ratio in place of slightly rich fuel-air ratio (6 %) as in case of  $T_3$ .

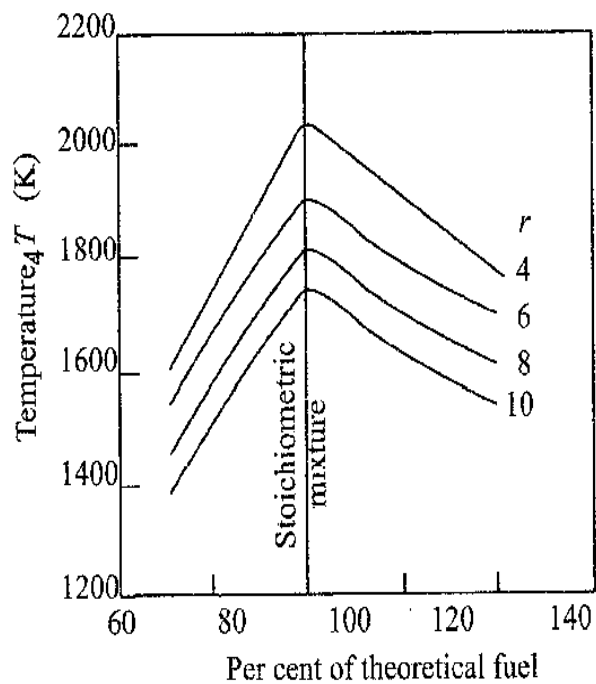

Fig. 2.10 Effect of fuel-air ratio on the exhaust gas temperature

- However, the behaviour of  $T_4$  with compression ratio is different from that of  $T_3$  as shown in Fig. 2.10 Unlike  $T_3$ , the exhaust gas temperature,  $T_4$  is lower at high compression ratios, because the increased expansion causes the gas to do more work on the piston leaving less heat to be rejected at the end of the stroke. The same effect is present in the case of air-cycle analysis also.

## 2.8 Comparison of air standard and actual cycles

The actual cycles for internal combustion engines differ from air-standard cycles in many respects. These differences are mainly due to:

- The working substance being a mixture of air and fuel vapour or finely atomized liquid fuel in air combined with the products of combustion left from the previous cycle.
- The change in chemical composition of the working substance.
- The variation of specific heats with temperature.
- The change in the composition, temperature and actual amount of fresh charge because of the residual gases.
- The progressive combustion rather than the instantaneous combustion.
- The heat transfer to and from the working medium
- The substantial exhaust blowdown loss, i.e., loss of work on the expansion stroke due to early opening of the exhaust valve.
- Gas leakage, fluid friction etc., in actual engines.

Most of the factors listed above tend to decrease the thermal efficiency and power output of the actual engines. On the other hand, the analysis of the cycles while taking these factors into account clearly indicates that the estimated thermal efficiencies are not very different from those of the actual cycles.

## 2.9 Deviation of Actual cycle from Fuel-Air cycle

- Major deviation from of actual cycle from the Fuel air cycle is due to
  - Variation in Specific heats
  - Dissociation
  - Progressive combustion
  - Incomplete combustion of fuel
  - Time loss factor
  - Heat loss factor
  - Exhaust blowdown factor

### 2.9.1 Time losses

Time losses may be burning time loss and spark timings loss.

#### a) Burning time loss

- In theoretical cycle, the burning is assumed to be instantaneous but actually burning takes some time. The time required depends upon F:A ratio, fuel chemical structure and its ignition temperature. This also depends upon the flame velocity and the distance from the ignition point to the opposite side of combustion chamber.
- During combustion, there is always increase in volume. The time internal between the spark and complete burning of the charge is approximately  $40^\circ$  crank rotation.

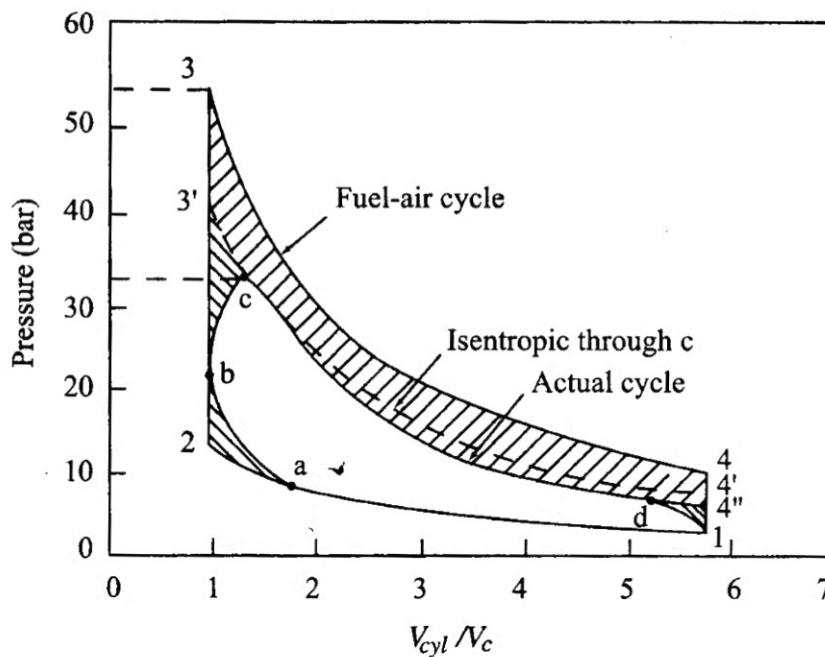

Fig. 2.11 Effect of time losses on p-V diagram

- The effect of time required for combustion; the maximum pressure is not produced when volume is minimum ( $v_c$ ) as expected. It is produced some time after TDC. Therefore, the pressure rises from b to c as shown in Fig. 2.11.
- The point 3 represents the maximum pressure if the combustion should have taken place instantly. The difference in area of actual cycle and fuel-air cycle shows the loss of power as shown in Fig. 2.11. This loss of work is called burning time loss. This time loss is defined as the loss of power due to time required for mixing the fuel with air and for complete combustion.

### b) Spark Timing Loss

- A definite time is required to start the burning of fuel after generating the spark in the cylinder. The effect of this, the maximum pressure is not reached at TDC and it reaches late during the expansion stroke. The time at which the burning starts is varied by varying the angle of advance (spark advance).
  - If the spark is given at T.D.C., the maximum pressure is low due to expansion of gases.
  - If the spark is advanced by  $40^\circ$  to start combustion at T.D.C., the combustion takes place at T.D.C. But the heat loss and the exhaust loss may be higher and again work obtained is not optimum.
- In the above two cases, the work area is less, and, therefore, power developed per cycle and efficiency are lower.

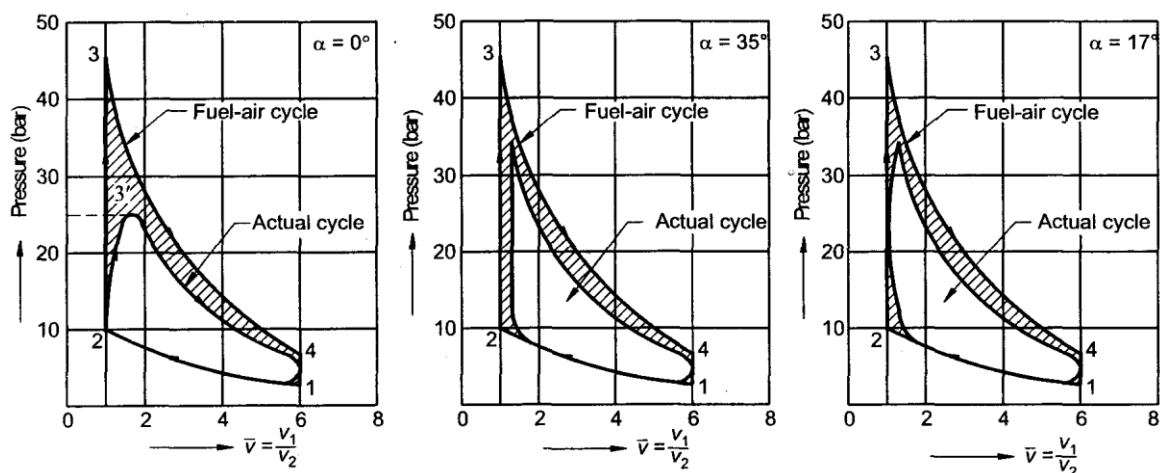

Fig. 2.12 Effects of angle of advance  $\alpha$  on  $p - v$  diagram

- Thus for getting maximum work output, a moderate spark advance of  $15^\circ$  to  $25^\circ$  is the best.

### c) Incomplete Combustion Loss

- The time loss always includes a loss due to incomplete combustion. It is impossible to obtain perfect homogeneous air-fuel mixture. Fuel vapour, air, and residual gas is present in the cylinder before ignition takes place. Under these circumstances it is possible to have excess oxygen in one part of the cylinder and excess fuel in another part of it. Therefore, some fuel does not burn or burns partially. Both CO and  $O_2$  will appear in the exhaust.

- It should be noted that it is necessary to use a lean mixture to eliminate fuel wastage while a rich mixture is required to utilize all the oxygen. Slightly leaner mixture will give maximum efficiency but too lean a mixture will burn slowly, increasing the losses or will not burn at all causing total waste. In the rich mixture some of the fuel will not get oxygen and will be completely wasted. Also, the flame speed in the rich mixture is low, thereby increasing the time losses and lowering the efficiency.

### 2.9.2 Direct heat loss

- During the combustion process and expansion process, the gases inside the engine cylinder are at a considerably higher temperature, so the heat is lost to the jacket cooling water or air. Some heat is lost to the lubricating oil where splash lubrication system is used for lubricating cylinder and piston.
- The loss of heat which takes place during combustion has the maximum effect, while that lost before the end of the expansion stroke has little effect, since it can do very small amount of useful work.
- During combustion and expansion, about 15% of the total heat is lost. Out of this, however, much is lost too late in the cycle to have done any useful work.
- In case all heat loss is recovered, about 20 percent of it may appear as useful work.

### 2.9.3 Exhaust blowdown loss

- At the end of exhaust stroke, the cylinder pressure is about 7 bar. If the exhaust valve is opened at B.D.C., the piston has to do work against high cylinder pressure costing part of the exhaust stroke. When the exhaust valve is opened too early entire part of the expansion stroke is lost.
- Thus, best compromise is that exhaust valve be opened  $40^\circ$  to  $70^\circ$  before B.D.C., thereby, reducing the cylinder pressure to halfway to atmosphere before the start of the exhaust stroke.

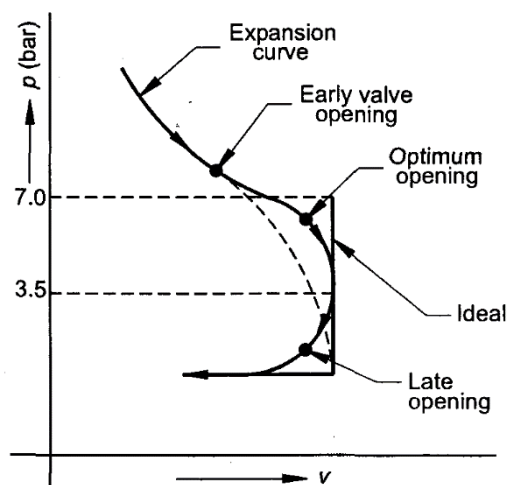

Fig. 2.13 Effect of blow down

### 2.9.4 Pumping losses

- In case of ideal cycles the suction and exhaust processes were assumed to be at atmospheric pressure. However some pressure differential is required to carry out the suction and exhaust processes between the fluid pressure and cylinder pressures.
- During suction the cylinder pressure is lower than the fluid pressure in order to induct the fluid into the cylinder and the exhaust gases are expelled at a pressure higher than the atmospheric pressure.
- Therefore some work is done on the gases during suction and exhaust stroke. This work is called pumping work as shown in Fig. 2.14 by shaded area.

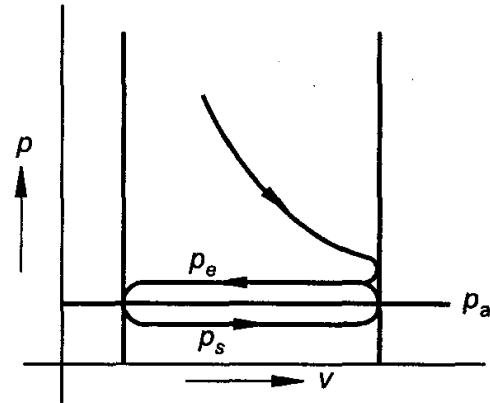

Fig. 2.14 Pumping Loss

### 2.9.5 Rubbing Friction Losses

- The rubbing friction losses are caused due to
  - Friction between piston and cylinder walls
  - Friction in various bearings
  - Friction in auxiliary equipment such as pumps and fans.
- The piston friction increases rapidly with engine speed and to small extent by in-creases in m.e.p.
- The bearing and auxiliary friction also increase with engine speed.
- The engine efficiency is maximum at full load and reduces with the decrease in load. It is due to the fact that direct heat loss, pumping loss and rubbing friction loss increase at lower loads.

### 2.10 Valve and port timing diagrams

- The valve timing diagram shows the position of the crank when the various operations i.e., suction, compression, expansion exhaust begin and end.
- The valve timing is the regulation of the positions in the cycle at which the valves are set to at open and close
- The poppet valves of the reciprocating engines are opened and closed by cam mechanisms. The clearance between cam, tappet and valve must be slowly taken up and valve slowly lifted, at first, if noise and wear is to be avoided. For the same reasons the valve cannot be closed abruptly, else it will bounce on its seat. (Also, the cam contours should be so designed as to produce gradual and smooth changes in directional acceleration).
- Thus, the valve opening and closing periods are spread over a considerable number of crankshaft degrees. As a result, the opening of the valve must commence ahead of the time at which it is fully opened (i.e. before dead centres). The same reasoning applies for the closing time and the valves must close after the dead centres.

### 2.10.1 Valve timing diagram of 4-Stroke Petrol engine

- The actual valve timings used for low speed and high speed engines are shown in Fig. 2.15 (a) and (b).

#### a) Inlet valve

- The inlet valve opening occurs a few degrees prior to the arrival of the piston at TDC during the exhaust stroke. This is necessary to insure that the valve will be fully open and fresh charge starts to flow into the cylinder as soon as the piston starts to move down.
- If the inlet valve is allowed to close at BDC, the cylinder would receive less charge than its capacity and the pressure of the charge at the end of suction stroke will be below atmosphere. To avoid this, the inlet valve is kept open for  $40^{\circ}$ - $50^{\circ}$  rotation of the crank after the suction stroke for high speed engine and  $20^{\circ}$  to  $25^{\circ}$  for low speed engine.
- The kinetic energy of the charge produces a ram effect which packs more charge into the cylinder during this additional valve opening. Therefore, the inlet valve closing is delayed.
- Higher the speed of the engine, the inlet valve closing is delayed longer to take an advantage of ram effect.

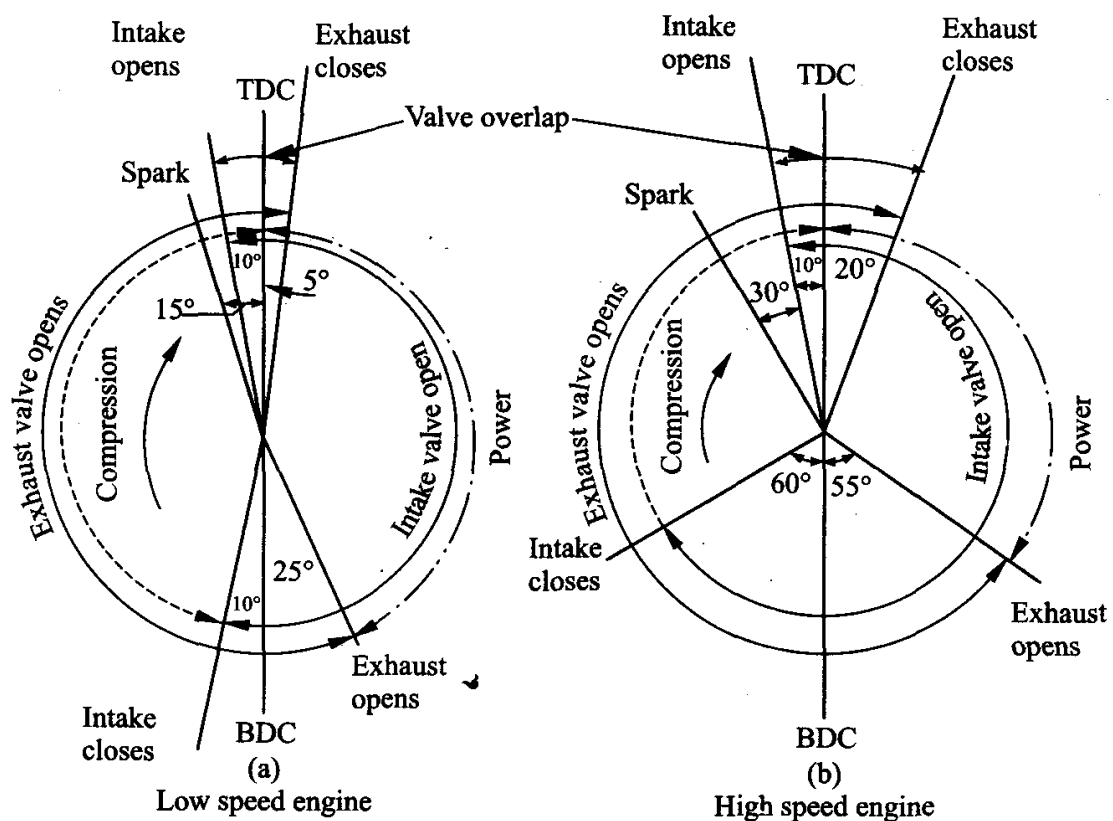

Fig. 2.15 Valve timing diagram for low and high speed 4-stroke SI engine

#### b) Exhaust valve

- The exhaust valve is set to open before BDC (say about  $25^{\circ}$  before BDC in low speed engines and  $55^{\circ}$  before BDC in high speed engines).

- If the exhaust valve did not start to open until BDC, the pressures in the cylinder would be considerably above atmospheric pressure during the first portion of the exhaust stroke, increasing the work required to expel the exhaust gases. But opening the exhaust valve earlier reduces the pressure near the end of the power stroke and thus causes some loss of useful work on this stroke.
- However, the overall effect of opening the valve prior to the time the piston reaches BDC results in overall gain in output.
- The closing time of exhaust valve effects the volumetric efficiency. By closing the exhaust valve a few degrees after TDC (about  $15^\circ$  in case of low speed engines and  $20^\circ$  in case of high speed engines) the inertia of the exhaust gases tends to scavenge the cylinder by carrying out a greater mass of the gas left in the clearance volume. This results in increased volumetric efficiency.

#### c) Ignition

- Theoretically it is assumed that spark is given at the TDC and fuel burns instantaneously. However, there is always a time lag between the spark and ignition of the charge. The ignition starts some time after giving the spark, therefore it is necessary to produce the spark before piston reaches the TDC to obtain proper combustion without losses. The angle through which the spark is given earlier is known as "**Ignition Advance**" or "**Angle of Advance**".

#### d) Valve Overlap

- From the valve timing diagram it is obvious that there will a period when both the intake and exhaust valves are open at the same time. This is called **valve overlap** (say about  $15^\circ$  in low speed engine and  $30^\circ$  in high speed engines). This overlap should not be excessive otherwise it will allow the burned gases to be sucked into the intake manifold, or the fresh charge to escape through the exhaust valve.

### 2.10.2 Valve timing diagram of 4-Stroke Diesel engine

- The actual valve timing diagram of 4-Stroke Diesel cycle engine is shown in fig. 2.16. The various strokes are modified for similar reasons as explained in case of petrol engine.

#### Fuel Injection Timing

- The opening of fuel valve is necessary for better evaporation and mixing of the fuel. As there is always lag between ignition and supply of fuel, it is always necessary to supply the fuel little earlier.
- In case of diesel engine, the overlapping provided is sufficiently large compared with the petrol engine. More overlapping is not advisable in petrol engine because the mixture of air and petrol may pass out with the exhaust gases and it is highly uneconomical. This danger does not arise in case of diesel engine because only air is taken during the suction stroke.

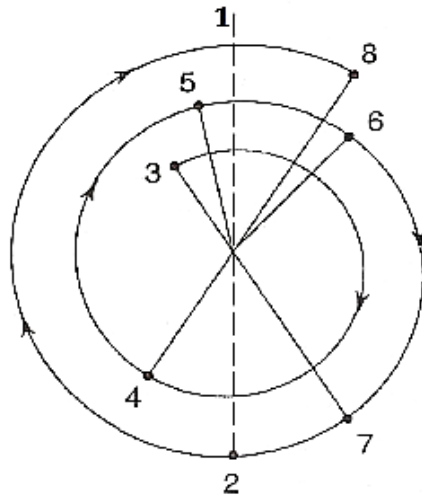

- 1 – TDC
- 2 – BDC
- 3 – Inlet Valve Opens
- 4 – Inlet Valve Closes
- 5 – Fuel Valve Opens
- 6 – Fuel Valve Closes
- 7 – Exhaust Valve Opens
- 8 – Exhaust Valve Closes

### 2.16 Valve Timing Diagram of 4-Stroke Diesel Cycle Engine

- The valve timing of diesel engine have to be adjusted depending upon the speed of the engine. The typical valve timings are as follows:
  - IV opens at  $25^{\circ}$  before TDC
  - IV closes at  $30^{\circ}$  after BDC
  - Fuel injection starts at  $5^{\circ}$  before TDC
  - Fuel injection closes at  $25^{\circ}$  after TDC
  - EV opens at  $45^{\circ}$  before BDC
  - EV closes at  $15^{\circ}$  after TDC

### 2.10.3 Port Timing Diagram of 2-stroke engine

- The port timing diagram for actual working of the two-stroke petrol and diesel engine is shown in Fig. 2.17. The port timing diagram is self-explanatory.

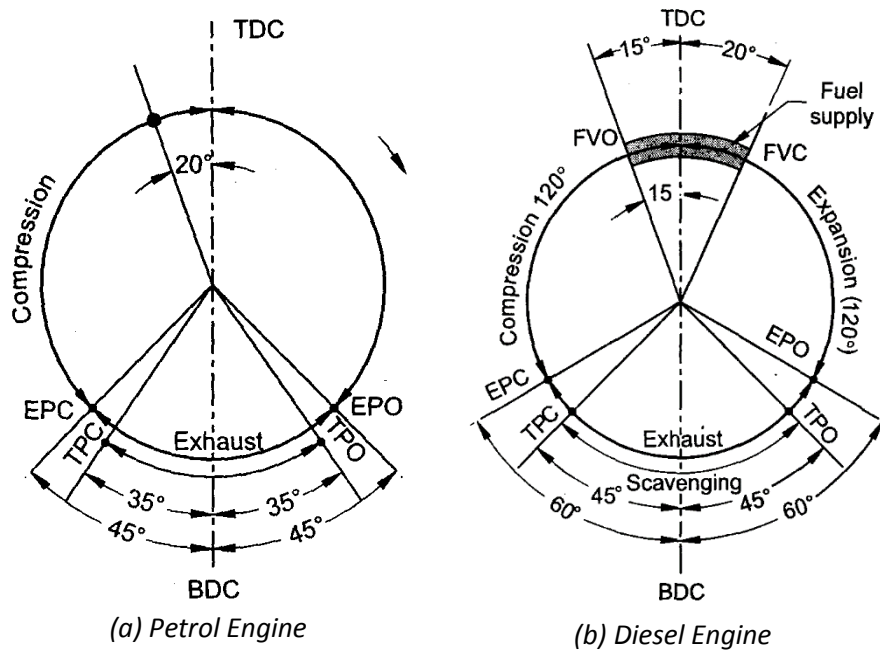

Fig. 2.17 Port Timing Diagram for 2-stroke Engine

## Tutorial Questions

|    |   |
|----|---|
| 1  | Give classification of IC Engines.  |
| 2  | Distinguish between SI engines and CI engines?  |
| 3  | Sketch and explain the valve timing diagram of a four stroke Otto cycle?                        |
| 4  | In what respect two stroke engines differs from 4-stroke engine Discuss?                        |
| 5  | Explain fuel injection system of an SI engine?  |
| 6  | What are the different lubrication systems available for IC engines?                            |
| 7  | Discuss the importance of cooling system for an IC engines. Describe different cooling systems? |
| 8  | List out the properties of fuel for (i) SI engine (ii) CI engine.                               |
| 9  | Explain lubrication system for IC engines?  |
| 10 | Explain cooling system for IC engines?  |

## Assignment Questions

|   |   |
|---|---|
| 1 | what is scavenging ? explain with sketches?   |
| 2 | List the factors causes detonation and explain in detail?   |
| 3 | Explain Magneto ignition system with a neat diagram?  |
| 4 | Explain coil ignition system with a neat diagram?   |
| 5 | What is Octane number? What is the role of Octane number in the performance of engine? For higher performance of engine which rated fuels are to be selected? |



---

# **UNIT 2**

## **COMBUSTION**

---





# Combustion in SI and CI Engines



## ***Course Contents***

- 7.1. Introduction to S.I. engine
- 7.2. Combustion Related Concepts and Definitions
- 7.3. Ignition Limit
- 7.4. Stages of combustion
- 7.5. Factors affecting ignition lag
- 7.6. Factors affecting the flame propagation
- 7.7. Abnormal combustion and knocking in S.I. engines
- 7.8. Effect of Engine Variables on Detonation in S.I. Engines
- 7.9. Control of knocking
- 7.10. S.I. engine Combustion Chamber Design
- 7.11. Different Types of Combustion Chambers for S.I. Engines in Use:
- 7.12. Introduction to C.I engine
- 7.13. Combustion Stages in C.I. Engines
- 7.14. Effect of Engine Variables on Delay Period
- 7.15. Knock in C.I. Engines (Abnormal Combustion)
- 7.16. Factors affecting the knocking in C.I engine
- 7.17. Comparison of the knocking in S.I. and C.I. engines
- 7.18. Combustion Chamber Design for C.I. Engines
- 7.19. Classification of Combustion Chambers for C.I. Engines

## 7.1. Introduction

- In Spark Ignition (S.I.) engine, fuel and air is mixed outside the engine cylinder in carburetor in proper proportion.
- Combustion is chemical reaction between hydrogen and carbon in fuel with oxygen in air. It produces  $\text{CO}_2$  and  $\text{H}_2\text{O}$  and liberates energy in the form of heat. Actual process of combustion is very complicated and lot of research is going on since many years.
- During combustion, large amount of heat is generated which is utilized to run the I.C engine.
- Combustion in S.I. engine requires following conditions:
  - (1) Proper proportion of air-fuel mixture should be compressed to required level (compression ratio = 6 to 10)
  - (2) Spark should take place with required intensity.
  - (3) Combustion should start at spark plug, and the flame should propagate in combustion chamber.

## 7.2. Combustion Related Concepts and Definitions

- The internal combustion engines derive their energy in the form of heat by combustion of homogeneous mixture of fuel and air in the combustion chamber.
- An enormous amount of research has been carried out, both theoretical and experimental, regarding the burning of this homogeneous mixture, but in actual practice the mixture inside the cylinder is never homogeneous.
- The reasons for such existent of heterogeneous mixtures in the cylinder may be non-uniform distribution of fuel and air in the combustion chamber or due to the dilution of mixture by the left over residual (burnt) gases in the clearance space of the cylinder of its previous stroke or for other reasons.
- The combustion problem of such mixtures is quite complex and intricate.
- However, the researches carried out in case of combustion of homogeneous mixtures in spherical bomb by igniting the fuel by a spark at a point have shown that there is a development of a flame defined as gas rendered luminous by liberation of chemical energy, which starts from the point of ignition and spreads continuously in outward direction.
- If the flame travels from the point of ignition up to the end of combustion chamber without any change in speed and shape, the combustion is said to be *normal*.
- If the mixture of fuel and air ignites prior to reaching the flame front, this phenomenon of combustion is called *auto-ignition*.
- The temperature at which the fuel will ignite itself without a flame is called *self-ignition temperature (S.I.T.)*.
- The auto-ignition of fuel is affected by various factors like density of charge (mixture of fuel and air); its temperature and pressure, turbulence and the air-fuel ratio.
- In case of normal combustion the forward boundary of reaction zone of a flame is called *flame front*. It is defined as the surface or area between the luminous region and the dark region of the unburned charge.
- The velocity of flame by which it moves in space is called *spatial velocity* which depends upon the shape and size of the combustion chamber.
- It has two components viz. transformation velocity and gas velocity.

- Former is defined as the relative velocity of burned gases with which the flame front moves from burned to unburned gases and it is the velocity by which the unburned gases approach the burning zone.
- The combustion is defined as the rapid and high temperature oxidation of fuel with liberation of heat energy.
- The main constituents of most fuels are carbon (C) and hydrogen (H<sub>2</sub>) and their burning involves the rapid oxidation of C to CO or CO<sub>2</sub> and of H<sub>2</sub> to H<sub>2</sub>O. Usually the combustion processes take place in gaseous phase.
- The requirement for initiating a combustion process are the presence of a combustible mixture of air and fuel, a means for initiating the combustion, the formation of a flame and its propagation across the combustion chamber.

### 7.3. Ignition Limit

- The flame inside the combustion chamber will propagate from spark plug to end of combustion chamber only if temperature inside the cylinder exceeds 1500 K and A/F ratio is within combustible limit i.e. between 9:1 to 21:1.
- Beyond this limit it may be too lean or too rich and practically the combustion will not be possible. As we know that Stoichiometric A/F ratio for isooctane (C<sub>8</sub>H<sub>18</sub>) is approximately 15:1.

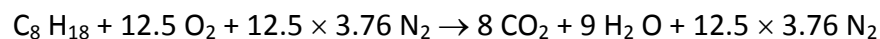

- If combustion is complete, CO<sub>2</sub> and H<sub>2</sub>O will come out in exhaust. If mixture is lean, excess air comes out in exhaust with CO<sub>2</sub> and H<sub>2</sub>O. If mixture is rich, incomplete combustion will take place resulting in reduced power and producing CO<sub>2</sub>, H<sub>2</sub>O and CO in exhaust.

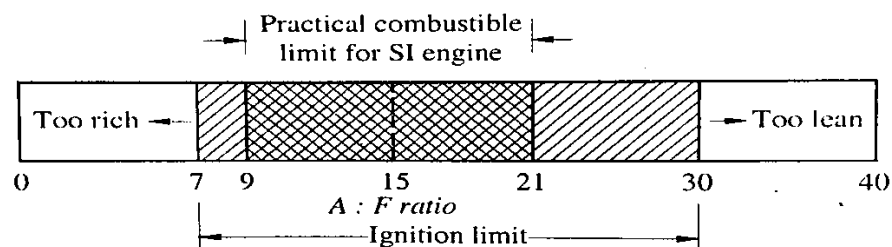

Fig.7. 1 Ignition Limit Hydrocarbons

### 7.4. Stages of combustion

- In I.C. engine, if inlet and exhaust valves are closed and piston moves from bottom dead centre (BDC) to top dead centre (TDC), compression will take place and similarly from top to bottom, expansion will take place. If combustion does not take place during this process, the pressure (p) versus crank angle (θ) diagram obtained is known as Motoring curve.
- Theoretical p- θ diagram where spark occurs at TDC, pressure suddenly rises due to combustion and, then expansion of combustion products take place.

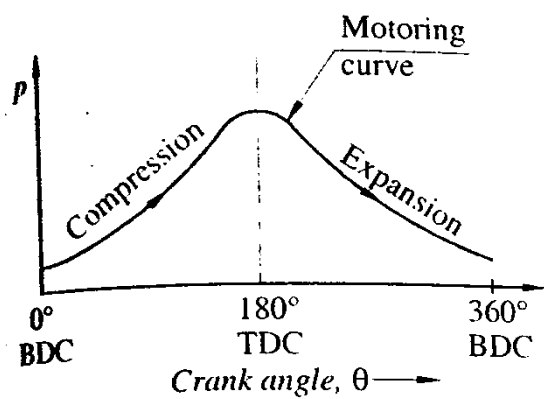
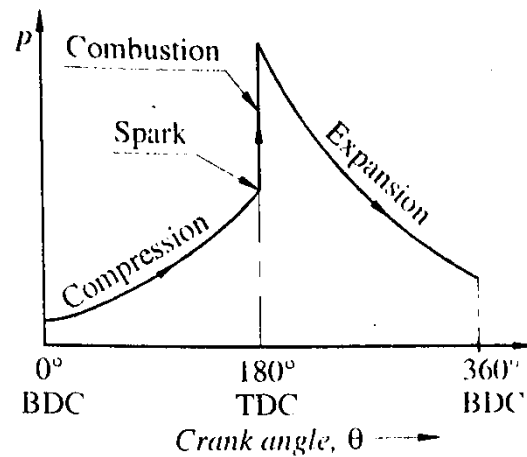

Fig. 7.2 (a)  $p - \theta$  diagram without combustion (non-firing)



(b) theoretical  $p - \theta$  diagram with combustion

- The actual  $p - \theta$  diagram with combustion is very complicated but as per this figure it is divided into three stages namely;
  - Stage I = A to B = Ignition lag,
  - Stage II = B to C = Flame propagation,
  - Stage III = C onwards = After burning.
- To achieve maximum advantage of high pressure generated during combustion, peak pressure should be after and near to the TDC.
  - If peak pressure is before TDC, it produces negative force on the piston which may damage the piston, piston rod, and crank shaft.
  - If peak pressure is after and far from TDC, force generated due to combustion cannot be fully utilized.
- Considering above fact spark timing (point A) should be selected that maximum pressure (point C) will be after and near TDC.

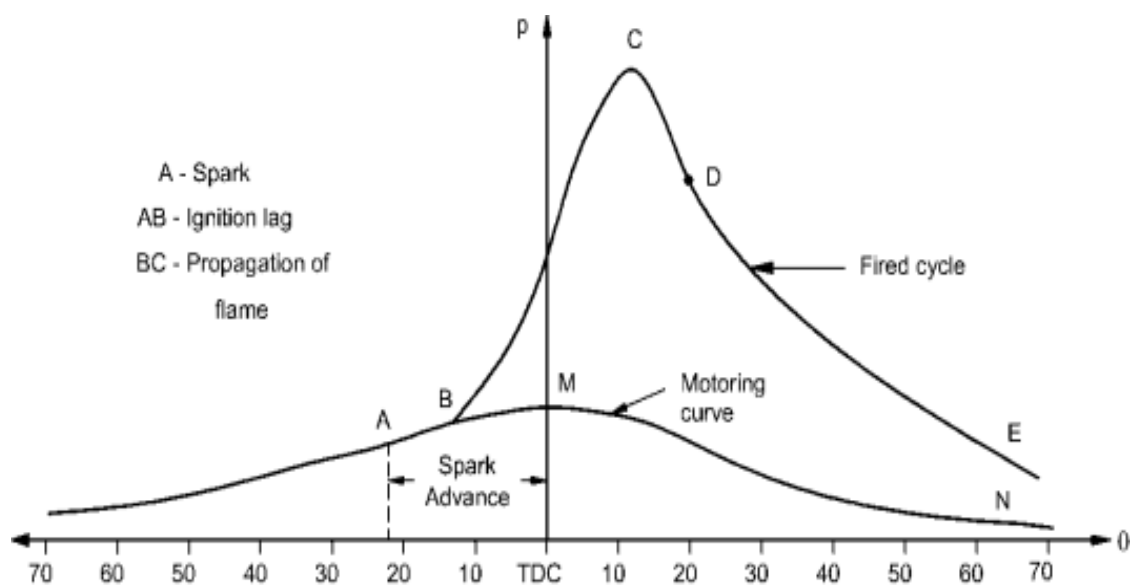

Fig 7.3 Actual  $p - \theta$  diagram for S.I. engine

### Stage I - Ignition lag:

- Ignition lag is the duration between spark (point A) and starting of combustion (point B).
- At point B, first rise of pressure detected and the actual curve differs from motoring curve. So time interval between spark (point A) and first pressure rise (point B) is known as ignition lag and generally it is expressed in terms of crank angle  $\theta$ .
- Ignition lag is also known as preparation phase during which spark, chemical process takes place, and flame generates. In SI engine combustion ignition lag is very important and it should be as small as possible for getting more power.

### Stage II - Flame propagation:

- The time duration between point B (combustion starts) and point C (Peak pressure) is known as flame propagation.
- The most of the heat is generated during this phase. Normally spark will occur (Point A) approximately  $30^\circ$  to  $35^\circ$  before TDC, so that peak pressure (Point C) is obtained  $5^\circ$  to  $10^\circ$  after TDC at cruising speed.
- As speed vary this spark timing should vary forgetting peak pressure at  $5^\circ$  to  $10^\circ$  after TDC.

### Stage III - After burning:

- Theoretically we can say that combustion should be completed at point C i.e. at maximum pressure in Fig.
- But actually combustion will continue after point C i.e. during expansion stroke which is known as after burning.
- It may be due to type of fuel, rich mixture etc. About 10% of heat may be liberated during this stage.

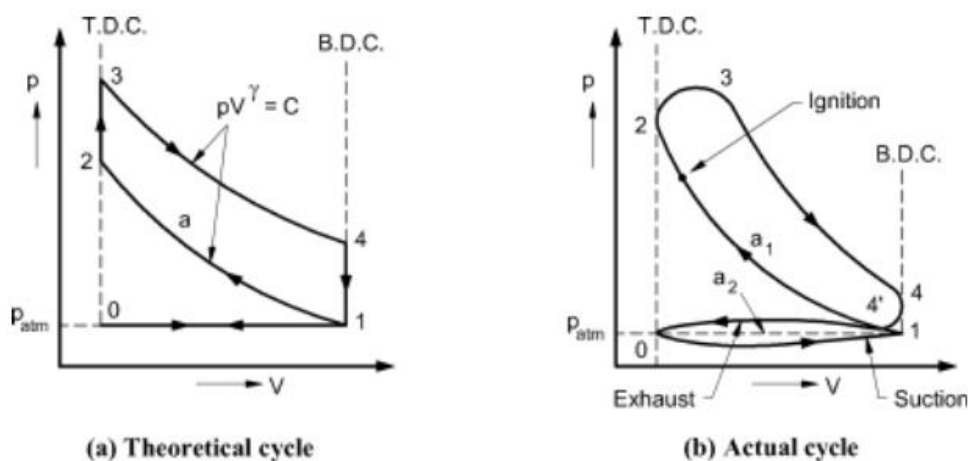

Fig 7. 4 Theoretical and Actual p-V diagram for S.I. engine

- In S.I engine, combustion takes place at constant volume and in C.I. engine at constant pressure. Area of actual p-V diagram is always less than theoretical p-V diagram. Area of p-V diagram means work done and it should be as large as possible.
- So to achieve this, actual p-V diagram should be close to theoretical p-V diagram. To achieve this, process of combustion should be as fast as possible i.e. timing or crank angle of 1<sup>st</sup> and 2<sup>nd</sup> phase should be as small as possible.

## 7.5. Factors affecting ignition lag

### 1. A:F ratio:

- Maximum power is produced at slightly richer mixture. At maximum power, heat generated is maximum, which will reduce Ignition-lag timing as shown.

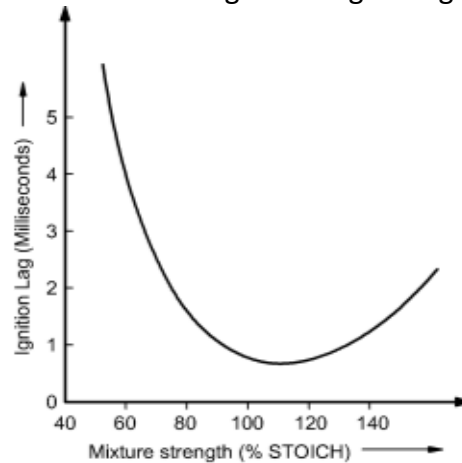

Fig.7. 5 Effect of A/F Ratio on Ignition Lag

### 2. Fuel:

- Chemical composition and nature of fuel plays vital role in combustion. The fuel with higher self-ignition temperature has longer ignition lag period.

### 3. Initial temperature and pressure:

- The chemical reaction between fuel and air greatly depends on temperature and pressure. As temperature and pressure increases reaction becomes fast which reduces ignition lag. Any factor which increases in-cylinder temperature or pressure will lead to decrease the ignition lag period. These factors may be supercharging, increasing compression ratio, retarding –the spark timing, etc.

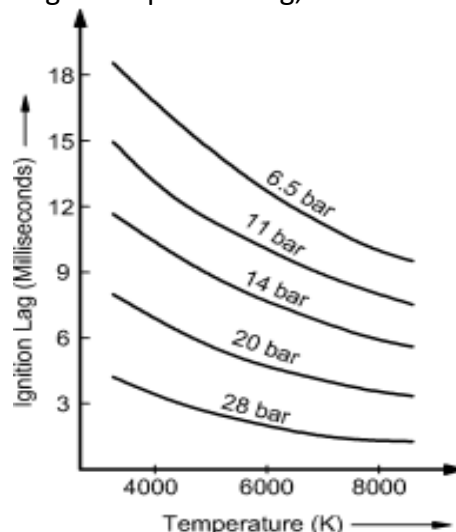
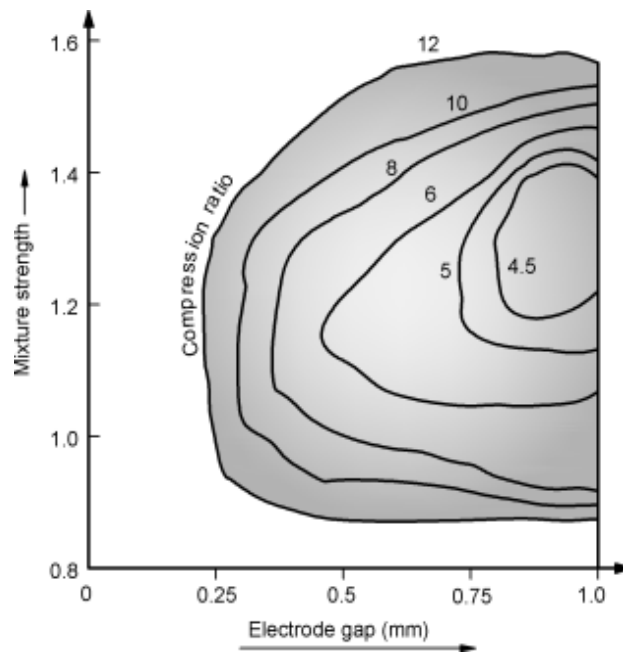

Fig.7. 6 Effect of Pressure and Temperature on Ignition Lag

### 4. Electrode gap:

- In a spark plug, distance between positive and negative electrode is known as electrode gap. The effect of electrode gap on mixture strength for different compression. As the electrode gap increases, higher voltage is required to produce the spark.



*Fig.7. 7 Effect of Electrode gap on A:F ratio required for different compression ratio*

- Following conclusion were made.
  - a) For small electrode gap (i.e. 0.25 mm) range of A:F ratio for development of flame nucleus is reduced.
  - b) For low compression ratio (say for CR=5) higher electrode gap is required.
  - c) As electrode gap increases the range of mixture strength increases.
  - d) As compression ratio increases combustion will be possible with small electrode gap.

#### 5. Turbulence:

- Turbulence means irregular motion of the charge inside the combustion chamber. Turbulence is directly proportional to engine speed.
- Ignition lag is not much affected by increasing the turbulence. So, engine speed does not affect the ignition lag measured in milli seconds but ignition lag in crank angle increases with speed.
- Therefore, angle of advance for spark timing increases with increasing speed and decreases with decreasing speed to maintain a constant ignition lag. Therefore, in all S.I engine automatic spark advance and retard mechanism is used to maintain constant ignition lag.

### 7.6. Factors affecting the flame propagation

- Flame propagation is very important in combustion process of S.I engines. The flame propagation depends on velocity of flame from spark plug to cylinder wall. The fast flame propagation will improve combustion and economy. A : F ratio and turbulence are major factors affect the flame propagation. Following are the factors that affect the flame propagation.

#### 1. A : F Ratio:

- As we know that maximum power is generated at slightly richer mixture. Therefore, maximum flame speed and flame propagation take place at approximately 10% richer mixture. For lean or too rich mixture flame propagation takes large time.

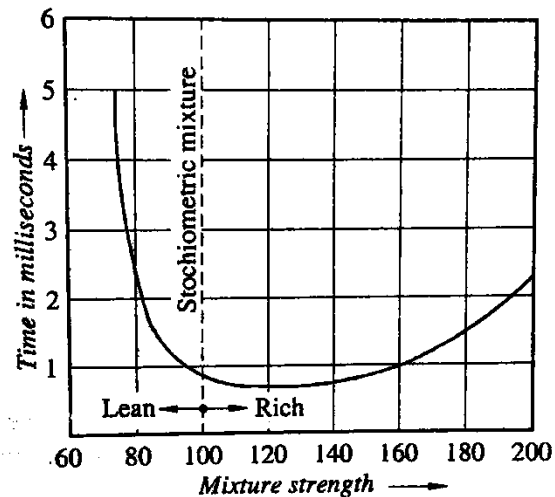

Fig. 7. 8 Effect of A/F Ratio on flame propagation

## 2. Compression Ratio (CR):

- Higher value of compression ratio increases the pressure and temperature of the working mixture and decreases the concentration of residual gases in the engine cylinder. This will speed up 1<sup>st</sup> phase (Ignition lag) and 2<sup>nd</sup> phase (flame propagation) of combustion. The drawback of increasing the in-cylinder temperature and pressure is to increase the possibility of detonation or knocking.

## 3. Intake temperature and pressure:

- As discussed earlier, as the intake temperature and pressure increases, the flame speed and flame propagation also increases.

## 4. Load on the Engine:

- As the load on an engine increases, the cycle pressure and temperature also increases. Hence the flame speed increases.

## 5. Turbulence:

- Irregular motion of charge entered inside the cylinder is known as turbulence. Turbulence is also generated inside the cylinder during compression by suitable design of the combustion chamber. In S.I. engine for combustion of fuel, the turbulence is very important factor because flame speed is directly proportional to the turbulence of the mixture. Advantages of turbulence are as follows:

- It provides better mixing of air and fuel.
- It increases the rate of heat transfer.
- Accelerate the chemical reaction, therefore combustion is improved.
- Flame propagation decreases and flame speed increases, therefore, weak (lean) mixture can also be burnt efficiently.

Besides all above advantages there are few disadvantages of high turbulence:-

- Due to high turbulence high heat transfer rate may cool the flame generated which lead to reduce flame velocity and flame may extinguish.

## 6. Engine Speed;

- Turbulence generated is linearly proportional to engine speed. So as engine speed increases, turbulence increases which will increase the flame propagation.

## 7.7. Abnormal combustion and knocking in S.I. engines

- In normal combustion the flame generated from spark plug and it travels to the end of cylinder wall smoothly without any disturbance.
- Under some operating conditions abnormal combustion may occur which will affect the combustion process. This results into the decreased power output, rough running of engine, and damage the engine parts also.
- Abnormal combustions are mainly of two types :
  - a) Detonation or knocking, and
  - b) Surface ignition.

### 1. Detonation or knocking

- The temperature at which fuel will be self-ignited without any external source (like flame front, or spark, etc.) is known as “Self-Ignition Temperature” (SIT).
- This process of ignition is called “auto ignition”.
- In normal combustion all the charge in the engine cylinder is ignited by flame front
- In knock combustion most of the charge is ignited by flame front but some amount of change will “auto ignite”.

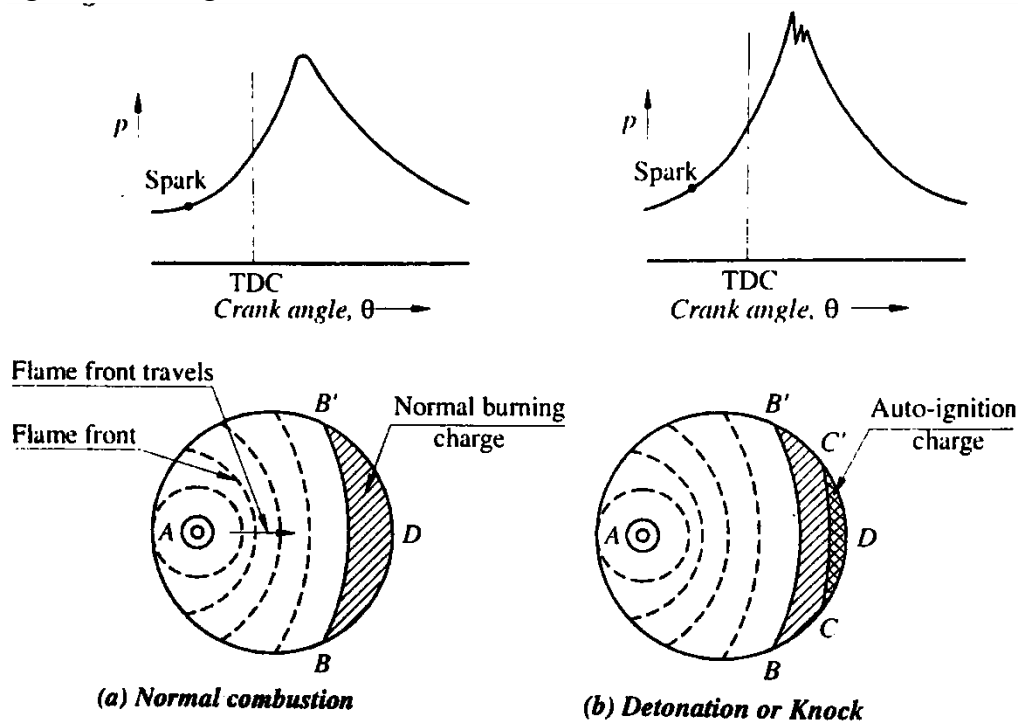

Fig.7. 9 Normal combustion and detonation

- Knocking or detonation is due to auto ignition of end charge before reaching the flume front in that part of the combustion chamber.
- In normal combustion flame will travel from A to BB' to D. Combustion of end charge between BB' and D takes place by flame front only
- The flame from A travels towards BB' two things will happen during this process, which will create the knocking.
  1. End charge between BB and D receives heat by flame front, and
  2. This end charge is compressed because of flame front.

- Both these factors will increase the temperature of end charge and reaches up to the self-ignition temperature (SIT). Therefore, the charge between CC' and D auto ignites before the flame is reached, which is known as knocking.
- Due to this knocking high pitching metallic sound is produced, combustion becomes erratic, power is drastically reduced and whole engine vibrates.

Salient features of knocking: -

1. Peak pressure for normal combustion is approximately 50 bar while during knocking it increases to 150 to 170 bar.

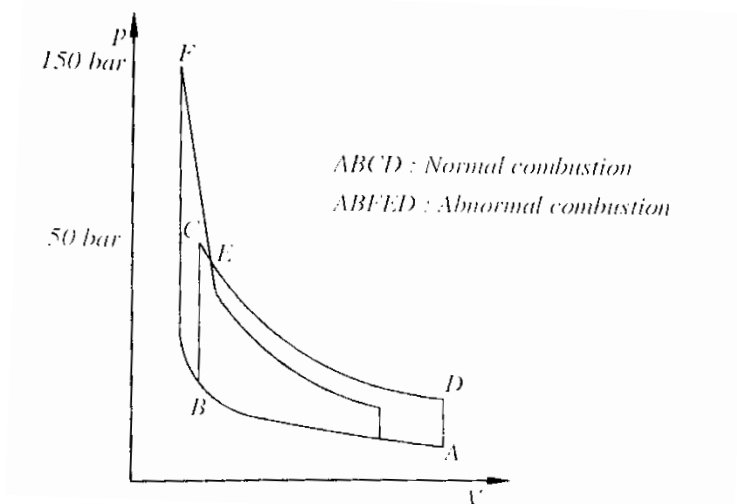

Fig.7. 10 Pressure rise due to knocking

2. Only 5% of total charge can produce the severe knock.
3. High pitching metallic sound is produced during knocking.
4. Inside the cylinder high velocity and pressure waves are produced.

## 2. Effects of detonation or knocking

### 1. Decrease In power output and efficiency:

- Heat transfer to cooling water increases during knocking, therefore, power output and efficiency of the engine decreases.

### 2. Pre-ignition:

- As rate of heat transfer increases, some parts inside the cylinder like valves, spark plug, etc. get overheated. Due to overheating hot spot ignition of charge occurs before the spark. This phenomenon is known as Pre-ignition and pre-ignition is very danger which may damage the engine and blast may also take place.

### 3. Mechanical damage:

- High pressure waves with large amplitude (190-210 bar) are generated during knocking. This will lead to wear different parts of engine like piston, cylinder, cylinder head, valves etc. Due to high heat transfer rate piston and piston rings may damage and even melts also. Spark plug is also over heated and may became hot spot.

### 4. Noise and Roughness:

- Due to high pressure waves engine parts vibrate, engine runs rough, and loud pulsating noise is created.

### 3. Abnormal Combustion (Surface ignition)

- Knocking or detonation discussed above is combustion knock, and it is due to end charge combustion by self-ignition before reaching the flame front. It is also known as spark knock.
- Abnormal combustion also occurs by surface ignition. In surface ignition, ignition will not occur by spark plug but due to any hot spot in combustion chamber.
- During combustion some of the part receives heat from combustion and becomes very hot and it acts as a spark plug. This hot part may be exhaust valve head, any carbon particle deposited on the piston or cylinder head or spark plug electrode.
- Carbon deposits also occupy some space inside the cylinder. So increases the compression ratio which causes for high temperature. Also carbon deposits are poor heat conductor which acts as an insulator leads to decreases the heat transfer and finally causes high in cylinder temperature.
- The surface ignition occurs before (pre-ignition) or after (post-ignition) normal ignition. Pre ignition is very dangerous as it creates the negative work which may damage the engine parts like piston, piston rod, and crank shaft. Pre-ignition and post-ignition may or may not causes knocking.
- Different type of combustion phenomenon available by this surface ignition are:
  1. Run-on surface ignition
  2. Run-away surface ignition
  3. Wild ping
  4. Rumble
- 1. **Run-on surface ignition:**
  - S. I. engine can be stop by switch-off the ignition system means power supply to spark plug is cut-off and hence spark does not occur by spark plug.
  - Theoretically engine should stop but actually it runs due to any hot surface (which may act as a spark plug) inside the engine cylinder. This phenomenon is known as “Run-on surface ignition”.
- 2. **Run-away surface ignition:**
  - Defective spark plug or exhaust valve receive the heat from combustion cycle and this heated spot causes pre-ignition. This type of surface ignition is very dangerous which may seizure or melt the piston and cylinder. The engine may catch fire, when fire enters in suction intake manifold.
- 3. **Wild ping:**
  - Some hot carbon deposits moves free inside the combustion chamber which provide source for combustion.
  - This combustion occurs erratic and unpredictable way produces very sharp knocking which is known as wild ping.
- 4. **Rumble:**
  - Due to hot spot inside the combustion chamber, combustion starts at a number of points (like diesel engine). It may be before (pre-ignition) or after (post-ignition) normal spark.
  - As combustion starts at number of points, heavy explosion of mixture take place which produces large erratic noise. High pressure waves produces resulting in engine vibration & noise which is known as engine rumble.

## 7.8. Effect of Engine Variables on Detonation in S.I. Engines

- It has been seen that the detonation in S.I. engine sets in if the end part of the gas auto-ignites before the flame front reaches it. The tendency to detonation will be reduced if the fuel has long ignition lag, high S.I.T. and high flame speeds or reduced time for flame travel. Therefore the onset of detonation is very dependent on the properties of fuel.
- Hence, those engine variables which tend to increase the ignition lag and increase the flame speeds would tend to reduce the detonation tendency. The factors are :
  1. **Intake temperature:**
    - Increased intake temperature reduces the delay period, therefore, increases the detonation tendency. However, it should be noted that the increased temperatures also increases the flame speed, thereby, reducing the detonation tendency.
    - But, the effect of increase temperature has more pronounced effect on delay period compared to flame speeds due to which the detonation tendency is increased with increase in intake temperature.
  2. **Intake pressure:**
    - Increased intake pressure increases the density of charge and reduces the delay period but increases the flame speed. The overall effect is to increase the detonation tendency.
  3. **Compression ratio:**
    - Increased compression ratio increases both the pressure and temperature and reduces the delay period, hence, the tendency to detonation increases.
  4. **Ignition advance:**
    - Advancing the spark timing increases the peak pressures of the cycle and thus reduces the delay period of end part of the gas in the combustion chamber, hence, tendency to detonate increases.
  5. **Coolant temperature:**
    - Raising the coolant temperature will increase the cylinder wall temperature and reduce the heat transfer rate between gas and cylinder walls.
    - Increased temperature of the gases would reduce the delay period and increase the detonation tendency.
  6. **Engine load:**
    - Higher loads on the engine increases the heating of the engine and reduces the delay period. Therefore the increased loads increases the detonation tendency of the engine.
    - It is for this reason the spark ignition engines are never overloaded.
  7. **Engine speed:**
    - Increase in engine speed increases the turbulence in the combustion chamber thereby increasing the flame speeds while the effect on the delay period is negligible. Due to this the increased speed of the engine reduces the detonation tendency.
  8. **Air-fuel ratio:**
    - It has been mentioned earlier that about 10% rich mixtures have the minimum delay period and the flame speeds are high.
    - But, it is observed that the effect of slightly rich mixtures on delay period is more dominant compared to flame speeds due to which the detonation tendency increases.

### 9. Engine size:

- Similar engines of various sizes have the delay period nearly the same. However, in case of larger sized engines the flame has to travel longer distance of combustion space compared to smaller sized engines.
- Therefore, the larger engines have more tendency to detonate compared to smaller engines.

### 10. Combustion chamber design:

- In general, more the compact combustion chambers, shorter will be flame travel and combustion time, hence, it will give better anti-knock characteristics.
- Also, if the combustion chamber design is such that it promotes turbulence then the flame speed will increase which would reduce the tendency to detonate.
- For above reasons the combustion chamber are designed nearer to spherical shape to reduce the distance of flame travel and shaped in such a way to promote turbulence

### 11. Location of spark plug:

- In case the spark plug is located centrally in the combustion chamber, it reduces the length of flame travel, hence, reduces the tendency to detonate. The flame travel can also be reduced by using two or more spark plugs.

### 12. Type of fuel:

- The fuels with lower self-ignition temperature or with its greater pre flame reactions will have more tendency to detonate.
- Fuels of paraffin series have maximum tendency to detonate and of aromatic series have minimum tendency to detonate.
- The naphthalene series fuels come in between the two.
- Table 7.1 gives the general summary of engine variables affecting the detonation in S.I. engines.

*Table 7. 1 Effect of engine variables on detonation in S.I. engines*

| Sr. No. | Increase in variable                    | Effective on ignition lag | Effect on flame speed/on time factor | Overall tendency for engine to detonate |
|---------|---|---------------------------|--------------------------------------|---|
| 1.      | Intake temperature                      | reduces                   | increases                            | increases                               |
| 2.      | Intake pressure                         | reduces                   | increases                            | increases                               |
| 3.      | Compression ratio                       | reduces                   | increases                            | increases                               |
| 4.      | Advancing ignition advance              | reduces                   | negligible                           | increases                               |
| 5.      | Coolant temperature                     | reduces                   | slightly increases                   | increases                               |
| 6.      | Engine load                             | reduces                   | increases                            | increases                               |
| 7.      | Engine speed                            | negligible                | increases                            | decreases                               |
| 8.      | Air-fuel ratio beyond 10% lean mixtures | increases                 | reduces                              | reduces                                 |
| 9.      | Engine size                             | nil                       | time factor high                     | increases                               |
| 10.     | Turbulence                              | negligible                | increases                            | reduces                                 |
| 11.     | Distance of flame travel                | negligible                | increases                            | increases                               |

## 7.9. Control of knocking

- Following are different parameter by which knocking tendency can be reduced.
  1. Increasing engine speed which increases the turbulence.
  2. Retarding spark timing.
  3. Reducing pressure in inlet manifold
  4. Using too lean or too rich mixture.
  5. Injecting the water inside the combustion chamber which reduces the in cylinder temperature, hence the knocking tendency decreases.
  6. Decreasing the compression ratio.
  7. Increasing turbulence by proper combustion chamber design.

## 7.10. S.I. engine Combustion Chamber Design

- Design of combustion chamber for S.I engine is very important for following reasons:
  1. To achieve high power output.
  2. To achieve high thermal efficiency.
  3. Smooth running of engine.
  4. To avoid knocking or detonation.
  5. Long life of engine.
  6. Minimum maintenance of engine.

### Objectives of Combustion Chamber Design for S.I. Engines

- A combustion chamber needs to be designed to meet the general objectives of developing high power output and high thermal efficiency with smooth running of engine and minimum octane number requirement of fuel. In order to achieve these objectives, following factors are to be kept in mind while designing the combustion chambers of S.I. engines.
  1. The **length of flame travel** from the spark plug to the farthest point should be kept minimum to avoid detonation problem.  
It involves the problem of location of spark plug and shape of combustion chamber. Usually the spark plugs are located at the central location or in some cases dual spark plugs are used.  
Also, the shape of combustion chambers should be as far as possible spherical to reduce the length of flame travel.
  2. To achieve **high speed of flame propagation**, an adequate amount of turbulence also ensures more homogeneous mixture by scouring away the layer of stagnant gas clinging to the chamber walls. However, excessive turbulence should be avoided since it increases the heat transfer losses to cylinder walls and affects the thermal efficiency of the engine.
  3. It should have small surface to volume ratio to minimise heat losses. A **hemispherical shape** provides minimum surface to volume ratio.
  4. It should provide large area to the inlet and exhaust valves with ample clearance around the valve head. It reduces the pressure drop across the valves, therefore, improves the volumetric efficiency. Use of sleeve valves are said to have low tendency to detonate compared to poppet valves due to absence of any high temperature area.
  5. Exhaust valves should not be located near the end gas location of combustion chamber to reduce the possibility of detonation since these valves are hottest spot in the combustion chamber.

6. The combustion chambers should be so designed that it can burn largest mass of the charge as soon as the ignition occurs with progressive reduction in the mass of charge burned towards the end of combustion.
7. Exhaust valve head is the hottest region of combustion chamber. It should be cooled by water jacket or by other means to reduce the possibility of detonation.
8. Octane number requirement of fuel increases with bore at the same piston speed when other factor remaining the same. Combustion time and cylinder inner surface temperature also increase with bore. For this reason the S.I. engine cylinder diameters are usually limited to 100 mm.
9. Thickness of cylinder walls should be uniform to avoid non-uniform expansion.

## 7.11. Different Types of Combustion Chambers for S.I. Engines in

### Use:

- Few important types of S.I. combustion chambers used are being discussed below :

#### 1. T-Head Combustion Chamber:

- This type of combustion chamber is shown in Fig. 7.11. It was used by Ford in 1908 but it is obsolete today. It has the following **disadvantages** :
  1. It needs two cam shafts to operate each valve separately.
  2. Long flame travel, therefore, it has more tendency to detonate. Compression ratios were limited to 5 : 1.
  3. Has high surface-volume ratio.

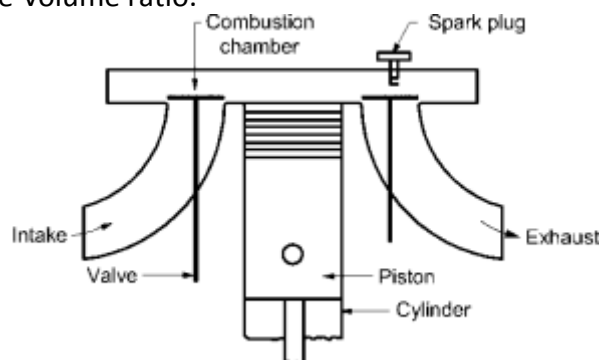

*Fig.7. 11 T-head combustion chambers*

#### 2. L-Head or Side Valve Combustion Chamber:

- Original form of L-head combustion chambers used up to 1930 is shown in Fig. 7.12. The top surface of the combustion chamber is in the form of a flat slab. Its intake valve and exhaust valve are kept side by side with spark plug location above the valves. Length of the combustion chamber covers the entire piston and valve assembly.
- **Advantages of L-head combustion chamber** :
  1. Easy to cast.
  2. Easy to carry out maintenance.
  3. Easy to lubricate the valve mechanism.
  4. Cylinder head can easily be removed, therefore, decarbonizing can be carried out without disturbing the valve gear mechanism.

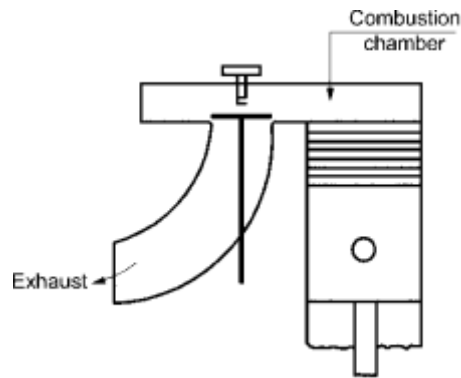
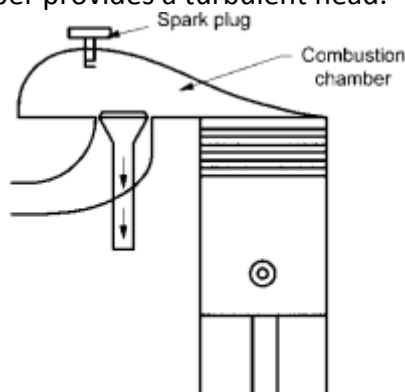

*Fig.7. 12 L-head combustion chamber*

- **Disadvantages of L-head combustion chamber :**
  1. There is a loss of velocity of intake air since it has to take two right angle turns before reaching the cylinder. It results into poor turbulence.
  2. Distance to be travelled by flame is more and it is super imposed by poor turbulence, therefore, tendency to detonation is more. Compression ratio is limited to 4 : 1.
  3. Mixing of air-fuel is unsatisfactory.
  4. It has low power and low thermal efficiency.

### **3. Recardo Turbulent Combustion Chamber:**

- The design of combustion chamber as suggested by Recardo in the year 1919 is shown in Fig. 7.13. However, modifications have been carried out in the design given at later stages.
- The Recardo combustion chamber overcomes the disadvantages experienced in the L-head combustion chamber.
- Recardo combustion chamber provides a turbulent head.



*Fig.7. 13 Recardo turbulent combustion chamber*

- The salient features of this combustion chamber are :
  1. Combustion chamber provides high turbulence. Because at top dead centre position only a thin layer of charge exists between the piston crown and combustion chamber, due to this the whole charge is pushed back in the combustion chamber during the compression stroke, therefore, it provides additional turbulence.
  2. Combustion chamber ensures a more homogeneous mixture of fuel and air by scouring away the layer of stagnant gas clinging to the chamber walls.
  3. The piston comes in closed contact with the combustion chamber head in this design, it reduces the effective length of flame travel. Hence, tendency to detonation is reduced.

4. Because of contact of piston with chamber the mass of end gas is negligible. Therefore impact of detonation will be negligible even if detonation occurs.
5. The detonation tendency is further reduced since the end gas is a thin layer and it is cooled by comparatively cooler cylinder head.
6. Spark plug is centrally located in the combustion chamber, the length of flame travel is reduced. It results into reduced tendency to detonate.

### **Modern S.I. Engine Combustion Chambers:**

- After the period of 1950 the combustion chambers used are either overhead valve, also called as I-head, combustion chambers or the F-head combustion chambers. Overhead combustion chambers were first introduced in Ambassador Car in the year 1959.
- The overhead and F-combustion chamber designs are based on principles of Ricardo combustion chamber with certain modifications.
- The advantages of overhead valve combustion chambers on L-head combustion chambers are as follows :
  1. Use of large valves or valve lifts and reduced passage ways provides better breathing of the engine, it increases volumetric efficiency of the engine with reduced pumping losses.
  2. It gives less tendency to detonate due to reduced flame travel.
  3. Less force on head bolts and reduced possibility of leakage.
  4. Exhaust valve is incorporated in the combustion chamber head instead of cylinder block. Therefore, heat failures limited to head only.
  5. Uses low surface-volume ratio, it reduces the heat losses and increases power output and efficiency.
- Few of the important combustion chambers of overhead valve type and F-head type are described below.

#### **1. Bath Tub Combustion Chamber:**

- This type of combustion chamber is shown in Fig. 7.14. It is simple and easy to cast. Both valves are mounted on the head with spark plug on one side of the combustion chamber.
- The charge at the end of compression stroke is pushed into the combustion space known as squish which provides additional turbulence.
- Since the valves are provided in a single row in the head, it reduces the size of the valves.
- Because of this the disadvantage of this design is that it reduces the breathing capacity of the engine with increased pumping losses.
- To overcome this difficulty, the modern engine design use relatively larger piston diameters compared to stroke length.

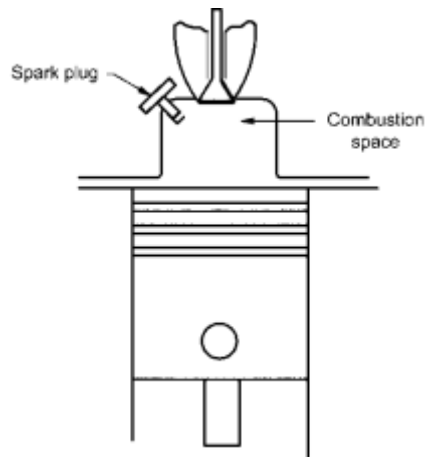

*Fig.7. 14 Bath tub combustion chamber*

## 2. Rover Head Combustion Chamber:

- The piston has cavity at the centre which produces high turbulence and reduces knocking tendency.
- High compression ratio can be used
- Due to high CR better combustion with high thermal efficiency can be achieved

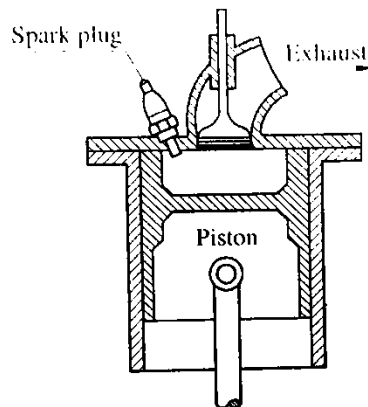

*Fig.7. 15 Rover Head Combustion Chamber*

## 3. Wedge Head Combustion Chamber:

- This type of combustion chamber is shown in Fig. 7.16. Valves are placed in inclined position.
- The end gas is kept cool by the intake valve and relatively cooler piston.
- Spark plug is approximately kept at the centre and it reduces the flame travel.

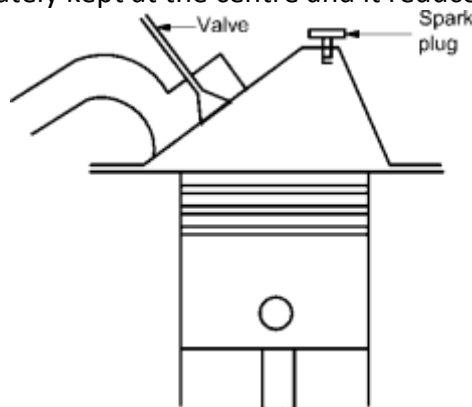

*Fig.7. 16 Wedge head combustion chamber*

#### 4. F-Head Combustion Chamber:

- Fig. 7.17 shows the combustion chamber similar to combustion chamber used by Willy's Jeep in India. This combustion chamber is also wedge shaped but similar in design to Rover head chamber.
- This combustion chamber has all the advantages of modern combustion chambers listed above. The inlet valve is kept in vertical position with large intake area to increase breathing of air and reduce the pumping losses.
- The air during compression stroke creates turbulence due to back flow of air into the chamber.
- Additional turbulence is created by the left hand portion of the piston head when at TDC by squish action.

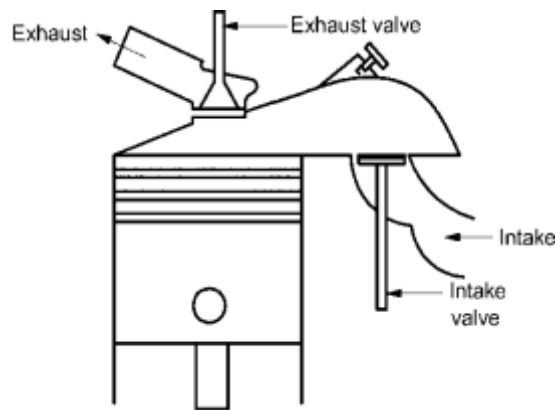
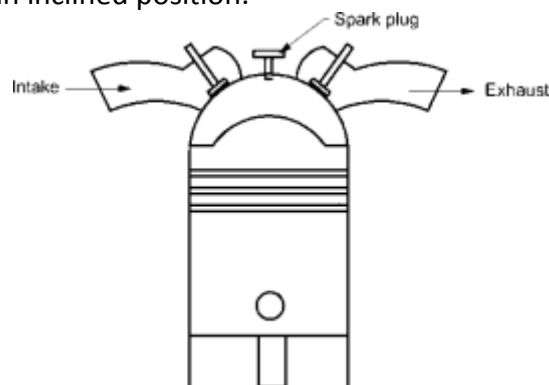

*Fig.7. 17 F-head combustion chamber*

- The spark plug is inclined and so located that it reduces the flame travel, hence, the detonation tendency.

#### 5. Combustion Chamber for Jaguar Engine:

- Fig. 7.18 shows the combustion chamber shape used for Jaguar engine.
- It utilises the principle that the hemispherical shape gives the minimum surface to volume ratio.
- Such a concept is useful to reduce the head losses thereby increasing the output power and thermal efficiency of the engine.
- The combustion chamber is designed hemispherical shape with inlet and exhaust valves placed on the sides of the head.
- Valves are operated in inclined position.



*Fig.7. 18 Combustion chamber to Jaguar engine*

- Hemispherical shape used not only reduces the heat transfer losses by virtue of low surface to volume ratio, it also permits to use the larger diameter valves, therefore, has higher volumetric efficiency.
- The crown of piston is so shaped to produce required turbulence, therefore, the flame speeds are increased, hence, reduces the tendency to detonate.
- Spark plug is located centrally which reduces the flame travel and again it helps in preventing detonation.

## **Section II: Combustion in C.I. Engines**

### **7.12. Introduction**

- C.I. engine only air sucks during suction and fuel is injected at the end of compression stroke.
- In S.I. engine nearly stoichiometric air fuel mixture is supplied while in C.I. engine 40 to 75% excess air is required for better combustion. For induction of this excess air, the size of C.I. engine compared to S.I. engine is always larger and heavier to generate the 1 same power.
- C.I. engine the combustion starts at 1 number of points simultaneously i.e. multipoint combustion takes place.
- In S.I. engine combustion takes place due to spark, whereas in C.I. engine combustion takes place due to compression ignition. As self-ignition temperature (SIT) of diesel is low, fuel can be ignited without spark.
- During compression stroke only air is compressed to higher pressure (CR = 16 to 22), so that temperature of air inside the cylinder increases (440 to 540°C) beyond SIT of diesel fuel. At the end of compression, diesel fuel is injected in liquid state at very high pressure (120 to 200 bar) with the help of fuel pump and injector.
- The atomized fuel vaporize, mix with air, and combustion starts.

### **7.13. Combustion Stages in C.I. Engines**

- In case of compression ignition engines the air alone is compressed and raised to high pressure and temperatures in the compression stroke by using high compression ratios.
- The temperature of air attained is far above the self-ignition temperature of the diesel fuel used.

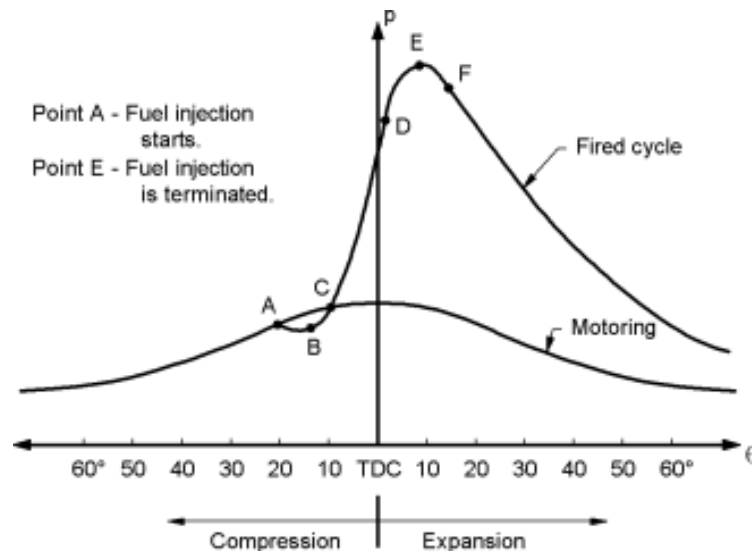

Fig.7. 19 Combustion stages in C.I. Engines

- The fuel is injected by a fuel pump into the combustion chamber by one or more jets under very high pressures of about 120-210 bar pressures at about (20°– 35°) before TDC. The point A represents the time at which the fuel injection starts on (p - θ) diagram shown in Fig. 7.19. Combustion takes place in four stages which are as follows :

### 1. First stage (Ignition delay period):

- The fuel leaves the nozzles initially in the form of a jet, and later on, it disintegrates into a core of fuel surrounded by a spray envelope of air and fuel particles due to atomization, vaporization and mixing with hot air.
- During vaporization process of fuel it receives its latent heat from surrounding air and this causes a slight drop in pressure in the cylinder as shown by curve AB.
- As soon as the vaporization is over, the preflame reactions of the mixture start. During such chemical reactions the energy is released at slow rate and the pressure starts building up.
- Therefore, the preflame reactions first start slowly and then accelerates until the ignition of fuel takes place. It corresponds to point C on diagram.
- The time interval between the start of fuel injection and commencement of combustion is called the **delay period**.
- The delay period can be divided into two parts as follows :

#### a) Physical delay:

- This represents the time interval from the time of injection of fuel to its attainment of self-ignition temperature during which the fuel is atomized, vaporized and mixed with air.

#### b) Chemical delay:

- After physical delay period is over, the time interval up to the time the fuel auto-ignites and flame appears is called chemical delay.
- During this period pre flame reactions take place. This period corresponds to ignition lag of S.I. engines.

- In practice, it is very difficult to separate exactly these two delay periods since the processes involved are very complex.

## **2. Second stage (Period of uncontrolled combustion):**

- Once the delay period is over the mixture of fuel and air will auto-ignite since it is above the self-ignition temperature.
- The flame appears at one or more locations where concentration of fuel and air mixture is optimum. This is due to the fact that the mixture present in the combustion chamber at the time of ignition is extremely heterogeneous unlike the homogeneous mixture of S.I. engines.
- Once the flame appears the mixture in other regions will either be burnt by propagating flames or it will auto-ignite because of the heat transfer from the burnt mixture and high temperatures existing in the combustion chamber.
- The fuel which is accumulated during the delay period is now ready for combustion and it would burn at an extremely rapid rate causing a steep rise in cylinder pressure and temperature.
- The rate of pressure rise depends upon the fuel injected and accumulated, which is directly proportional to the time of injection and the engine speed.
- Higher the delay period, higher would be the rate of pressure rise. During this period it is difficult to control the amount of fuel burning, for this reason, this period of rapid combustion is called the period of uncontrolled combustion as represented by curve CD in Fig. 7.19.

## **3. Third stage (Period of controlled combustion):**

- Once the fuel accumulated during the delay period is burnt in the period of uncontrolled combustion, the temperature and pressures in the cylinder will be so high that the further quantity of fuel injected will burn as soon as it leaves the nozzle provided sufficient oxygen is present in the cylinder.
- Therefore the rate of pressure rise can now be controlled by controlling the rate of fuel injection. This period of combustion is known as period of controlled combustion represented by curve DE.

## **4. Fourth state (After burning):**

- Theoretically the combustion is completed at the point the maximum pressure is attained during the cycle corresponding to point E few degree after TDC.
- However, the burning of fuel continues during its expansion stroke due to reassociation of dissociated gases and any unburned fuel due to heterogeneous condition of mixture. This phase of combustion is called after burning.

## **7.14. Effect of Engine Variables on Delay Period**

### **1. Compression ratio:**

- Increased compression ratio increases the density, pressure and temperature of the charge. Increased temperatures and pressure reduces the delay period.

### **2. Inlet pressure (supercharging):**

- Increased inlet pressures increases the pressures in the compression stroke and reduces the delay period.

### 3. Intake temperature:

- Higher intake temperatures will result into high temperatures at the time of fuel injection, therefore, it will reduce the delay period.

### 4. Engine speed:

- Increased speed will increase the delay period in terms of degrees of crank rotation, since the fuel pump is driven by the engine through gears. Therefore, during the delay period more fuel will be accumulated in the cylinder with increased speed and burning of this fuel during the period of uncontrolled combustion will result into high rate of pressure rise and high temperatures. It also results into better mixing of fuel and air due to increased turbulence.

### 5. Jacket water temperature:

- Increased jacket water temperature increases the air temperature in the cylinder, hence, reduces the delay period.

### 6. Load on engine:

- Increased loads on the engine reduces delay period. Since the air-fuel ratio decreases with the increase in operating temperatures.

### 7. Injection pressure:

- Increased injection pressures will give better atomization of fuel. It generally tends to reduce the delay period slightly.

### 8. Fuels:

- Higher the self-ignition temperature of the fuel, higher will be the delay period.

### 9. Injection timing:

- If fuel is injected much before TDC the delay period is larger since the pressure and temperatures in the cylinder are low. It will give extremely high rate of pressure rise during the period of uncontrolled combustion.
- Too late injection will reduce delay period but it would result in poor efficiency of the engine and the engine will not run smoothly.

### 10. Engine size:

- It has no effect on delay period in terms of time. However, large engines operate at lesser speed, therefore, delay period in terms of crank angle is smaller. Hence, less fuel enters the cylinder and the engine will run smooth.

## **7.15. Knock in C.I. Engines (Abnormal Combustion)**

- In C.I engine as delay period increases, the amount of fuel injected and accumulated in combustion chamber increases. A very high temperature and pressure is generated by combustion of this large amount of fuel is known as knocking or detonation in C.I engine.
- “Accumulation of fuel during large delay period creates very high pressure, it is known as knocking in C.I. engine.”
- This high rate of pressure rise creates pulsating combustion which produces heavy noise.
- In C.I. engine knocking occurs during initial phase of combustion i.e. as delay period is completed and uncontrolled combustion starts.

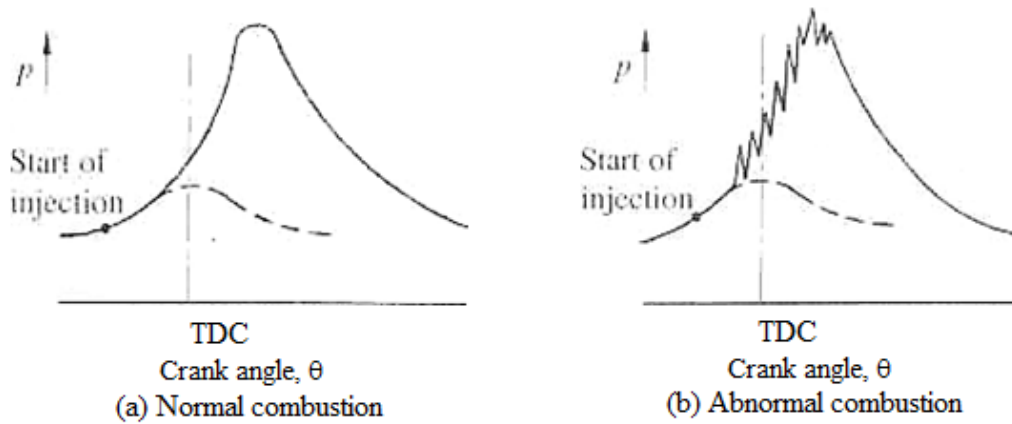

Fig.7. 20  $p - \theta$  diagram of C.I. engine with and without Knocking

## 7.16. Factors affecting the knocking in C.I engine

Table 7. 2 Factors affecting the knocking in C.I engine

| Sr. No | Variable increases                 | Effect on knocking tendency |
|--------|------------------------------------|-----------------------------|
| 1.     | Fuel (Cetane No.)                  | Decreases                   |
| 2.     | Intake air/fuel/Jacket water temp. | Decreases                   |
| 3.     | Intake Pressure (supercharging)    | Decreases                   |
| 4.     | Load (F: A Ratio)                  | Decreases                   |
| 5.     | Injection pressure                 | Decreases                   |
| 6.     | Injection advance angle            | Increases                   |
| 7.     | Engine size                        | Decreases                   |
| 8.     | Speed                              | Increases                   |
| 9.     | Compression ratio                  | Decreases                   |

## 7.17. Comparison of the knocking in S.I. and C.I. engines

- (1) In S.I. engine knocking takes place at the end of combustion process while in C.I. engine it takes place at the beginning of combustion.
- (2) In S.I. engine knocking is due to end charge auto-ignition before reaching the flame while in C.I. engine knocking is due to auto-ignition of more fuel accumulated due to long delay period.

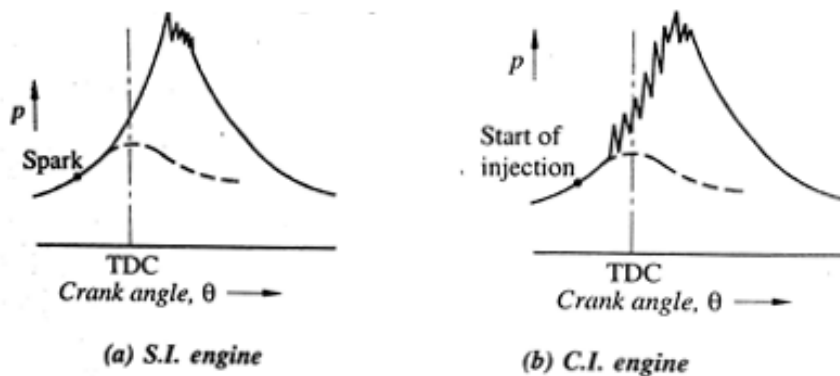

Fig.7. 21  $p - \theta$  diagram of S.I and C.I. engine

- (3) In S.I. engine pressure rise is very high during knocking due to homogeneous mixture as compared to the C.I. engines.

- (4) Chances of pre-ignition in the S.I. engine is more because air-fuel mixture enters during suction stroke while in the C.I. engine fuel is injected at the end of compression stroke.
- (5) In the C.I engine knocking is due to delay period and delay period cannot be zero. There is always pressure rise due to accumulation of fuel during delay period. Therefore, the C.I. engine is known as knock engine. As degree of pressure rise increases above certain limit which may start to produce audible noise and vibration. It is the starting of knocking. Therefore, in the C.I. engine it is difficult to distinguish between knocking and non-knocking operation.
- Table 7.3 gives the factors which reduce the detonation and knocking tendency in S.I. and C.I. engines.

*Table 7.3 Factors tending to reduce detonation and knocking in S.I. and C.I. engines*

| Sr. No. | Factors                           | S.I. engine | C.I. engine |
|---------|-----------------------------------|-------------|-------------|
| 1.      | Compression ratio                 | low         | high        |
| 2.      | Inlet temperatures                | low         | high        |
| 3.      | Inlet pressures (super charging)  | low         | high        |
| 4.      | Self ignition temperature of fuel | high        | low         |
| 5.      | Time lag or delay period of fuel  | long        | short       |
| 6.      | Load on the engine                | low         | high        |
| 7.      | Combustion wall temperature       | low         | high        |
| 8.      | Speed (rpm)                       | high        | low         |
| 9.      | Cylinder size                     | small       | large       |

## 7.18. Combustion Chamber Design for C.I. Engines

### Objectives

- In the C.I engine during induction, suction, and compression only air is there and fuel is injected at the end of compression. The time available for vaporization and mixing with air is very limited. Also for better mixing and better combustion air swirl is required which gives better combustion.
- For better combustion atomization, vaporization and proper mixing with air is required in minimum time and result of all these give high power, better efficiency, smooth and noiseless engine running, and shorter delay period which reduces probability of knocking.
- To achieve all of the above advantages the design of C.I engine combustion chamber becomes more complicated and swirl is very important in the C.I engine.

### Air Swirl:

- For proper mixing of fuel and air in the combustion chamber the various methods of air movement are employed called **air swirl**. Various types of air swirl are being discussed below :

#### 1. Induction Swirl

- In this method swirl is provided to incoming air to the cylinder during suction, that's why it is known as induction swirl.
- Different methods of giving swirl to incoming air are shown in fig 7.22 in which air enters at some angle and gets the swirl.
- Fig. 7.22 (b) shows a masking or shrouding one side of the inlet valve, so that air enters only around the part of periphery of the valve and air swirl is produced. The angle of mask used usually varies from  $90^\circ$  to  $140^\circ$ .
- The best tangential direction of air movement can be obtained by turning the valve around its axis. Fig. 7.22 (c) illustrates the method of producing air swirl by casting a lip on one side of the inlet valve. Air enters from the top and due to lip it gets the swirl.

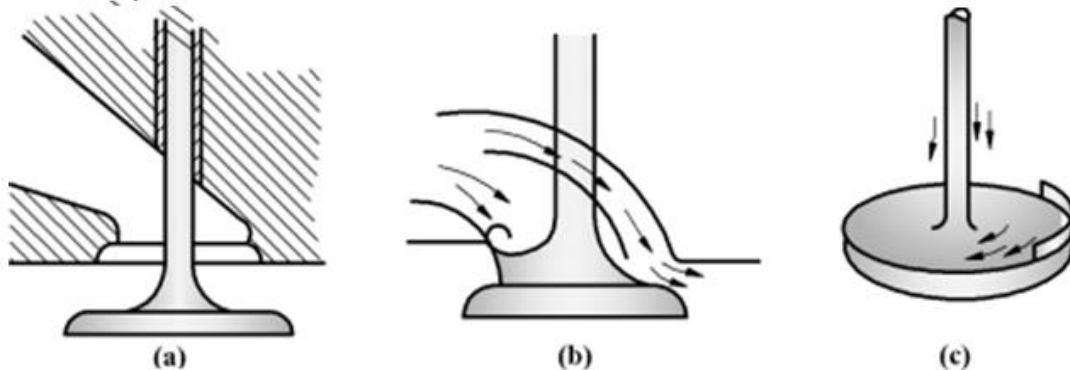

*Fig.7. 22 Different methods of achieve induction swirl*

## 2. Compression Swirl

- In this method air swirl is produced during compression stroke. At the top of the piston different types of cavity is formed which gives different type of swirl during compression. It is shown in Fig. 7.23 (a) and (b).

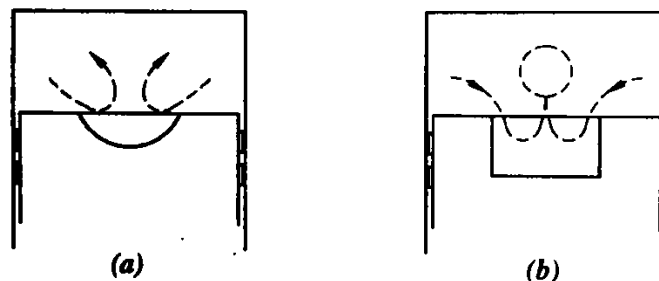

*Fig.7. 23 Compression Swirl*

## 3. Combustion Induced Swirl

- In this method swirl is produced by high pressure generated during first part of combustion of fuel. The piston head have different types of design which help to generate the swirl during combustion. This method is employed in pre-combustion and air cell combustion chamber designs.

## 7.19. Classification of Combustion Chambers for C.I. Engines

- The combustion chamber for the C.I. engines are classified as follows:
  - a. Open combustion chamber or Direct injection (D.I.) combustion chambers.
  - b. Pre-combustion chamber.
  - c. Turbulent combustion chamber or Indirect injection combustion chamber.
  - d. Special combustion chambers.

### 1. Open or Direct Injection (DI) Combustion Chambers

- In an open combustion chamber the space between the piston and cylinder head is open i.e. no restriction in between. Therefore, all air is contained in single space between the piston and cylinder head. The fuel is directly injected inside this space that's why it is also known as direct injection engine or in short D.I. engine.
- To achieve better combustion and swirl different types of cavity are formed in piston crown and cylinder head.
- In some cases, the shape of cylinder head provides a cavity to create favourable conditions for better mixing and better burning.
- The salient features of open combustion chamber are:
  - (1) Less turbulence is generated in this type, so heat loss is less and thus, starting is easier.
  - (2) Excess air required is more, so engine size increases, and thermal efficiency also increases.
  - (3) Generally they are used for large capacity, and low speed engines.

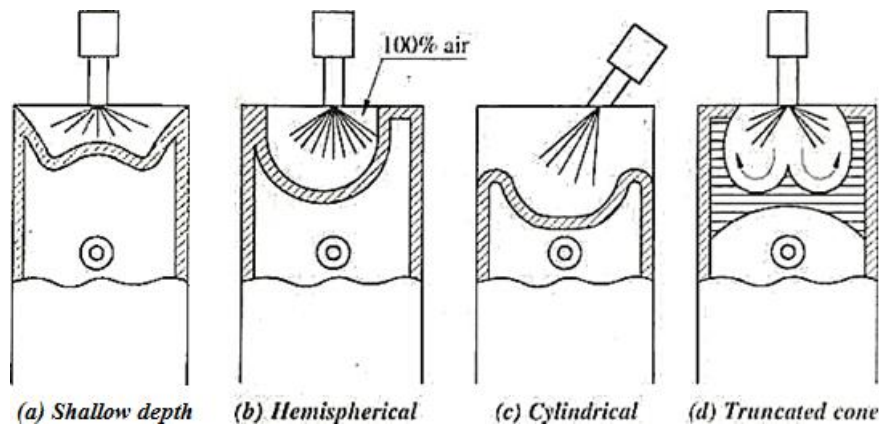

Fig.7. 24 Cavity in piston crown

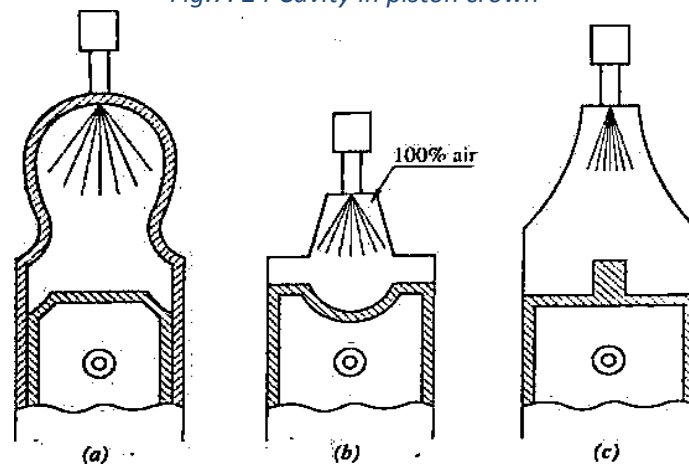

Fig.7. 25 Cavity in piston crown

- Advantages and disadvantages of this type of combustion chambers are as follows :

**Advantages:**

1. The thermal efficiency is high because heat transfer losses are less.
2. Easier starting because heat transfer losses are less.
3. Simple in construction.
4. In case of slow speed engines less costly fuels with longer delay can be used.

Disadvantages:

1. Engine size becomes large for generating same power due to large excess air required.
2. Due to less turbulence, high injection pressure is required with multiple hole nozzle.
3. Maintenance cost is higher.

## 2. Pre-Combustion Chamber

- A small additional chamber called as pre-combustion chamber is connected with main combustion chamber where fuel is injected in this pre-combustion chamber. Both these chambers are connected with small holes.
- As fuel is injected, combustion starts at pre-combustion chamber and products of combustion rush out through small holes to main combustion chamber with very high velocity, thus it generates turbulence as well as swirl which produces bulk combustion in the main combustion chamber. About 80% of energy is released in main combustion chamber.
- The first combustion starts at pre-combustion chamber due to high temperature of it and it propagates to main combustion chamber, thus the delay period is reduced and poor grade fuel can also be easily burnt.

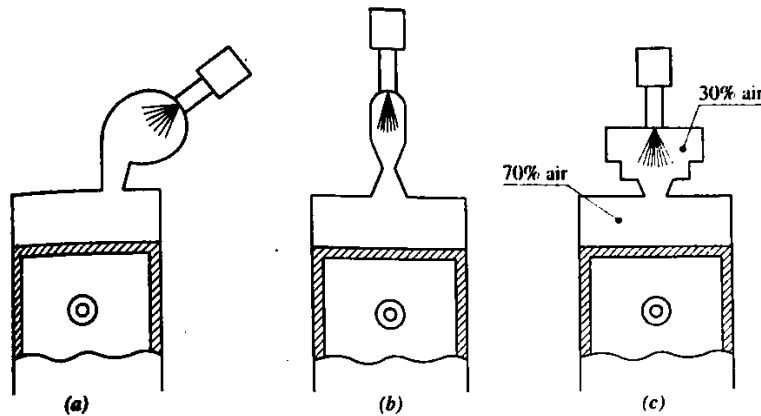

*Fig.7. 26 Precombustion chamber*

Advantages:

1. Fuel with wide range of Cetane No. can be used.
2. As injection pressure is low, simple fuel nozzle can be used.
3. Smoother running of engine.
4. Engine can be run at high speed.
5. As delay period in main combustion chamber is very small, knocking tendency is very less. Also engine can run with higher compression ratio.

Disadvantages:

1. Engine design becomes complicated due to pre-combustion chamber.
2. Heat loss from pre-combustion chamber is high.
3. Due to high heat loss cold starting is difficult.
4. The fuel consumption is high and thermal efficiency is low.

### 3. Turbulent or Indirect Injection (IDI) Combustion Chambers

- These combustion chambers are similar as that of pre-combustion chamber. The difference is that in pre-combustion chamber only 20 to 25% of total air enters while in these type 80 to 90% of total air circulates in pre-chamber.
- As high rate of “swirl” produces in this type, it is also known as swirl combustion chamber. During compression stroke most of the air from main combustion chamber enters to pre-combustion chamber, where high rate of swirl is produced.
- Fuel is injected in this pre-combustion chamber and the ignition and bulk of the combustion takes place therein. Few configurations of these type are shown in Fig.7.27 (a) and (b).

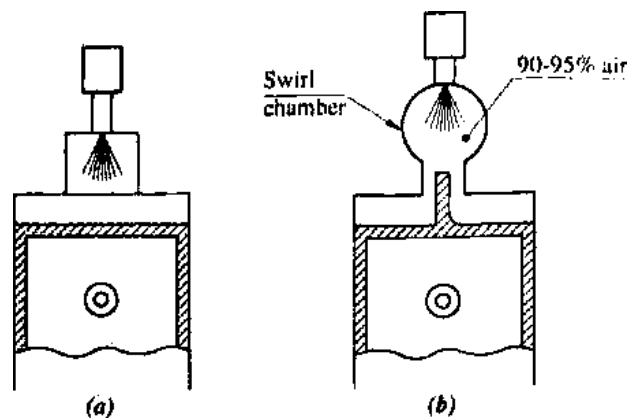

Fig.7. 27 Turbulent or Indirect Injection (IDI) Combustion Chambers

- The advantages and disadvantages of this type are listed below:

Advantages:

1. Due to high rate of swirl comparatively rich mixture (low A:F ratio) can be used which makes engine compact for given output.
2. Large range of Cetane No. fuel can be used.
3. Injection pressure and pattern of injection is not very important due to swirl f thus simple nozzle can be used.
4. Smooth running and low maintenance of the engine.
5. The engine can be operated at high speed because delay period is very small, thus probability of knocking is less.

Disadvantages:

1. Due to large heat loss to cylinder wall fuel consumption increases (high bsfc).
2. Low thermal efficiency due to heat loss.
3. Cold starting of engine is difficult.

### 4. Special combustion chambers

#### 1. M.A.N. Combustion Chamber

- Dr. Meurer of Maschinenfabrik Augsburg Nürnberg (M.A.N.) of Germany in 1954 developed a special type of open combustion chamber, also called as 'M' combustion chamber.
- It is suitable for small, high speed engines. In this design, the combustion chamber has a spherical cavity in the piston as shown in Fig. 7.28.
- The fuel spray impinges tangentially on the cavity and it spreads over the entire chamber. Such type fuel spray impingement was believed to be undesirable in earlier designs of open combustion chambers.

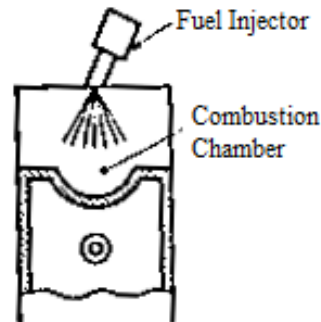

*Fig.7. 28 M.A.N. combustion chamber*

- But according to the theory used in this design it is suggested that the air borne fuel spray in the cavity makes homogeneous mixture and it auto ignites before impingement with normal delay period, while the remainder fuel impinging on the cavity walls have to evaporate from the cavity prior to combustion.
- It controls the rate of pressure rise in the second stage of combustion and gives smooth running of engine.
- However, it is further possible to control the air borne fuel spray by varying the distance between the nozzle tip and the combustion chamber walls.

#### Advantages:

1. Large range of fuel can be used, so poor quality of fuel with low cetane no. can also be used.
2. Better combustion and low exhaust emission.
3. More power because of high volumetric efficiency.
4. Easy cold starting.
5. No combustion noise.
6. Low rate of pressure rise.

#### Disadvantages:

1. Poor performance and high emission at low load on engine.

## 2. Air-Cell Combustion Chamber

- Air-cell combustion chamber design used for Lanova engine is represented in Fig. 7.29. In this case a separate air-cell through a small neck communicates with the main combustion chamber.
- The fuel is injected across the main chamber into the neck of air-cell which is designed to run hot.

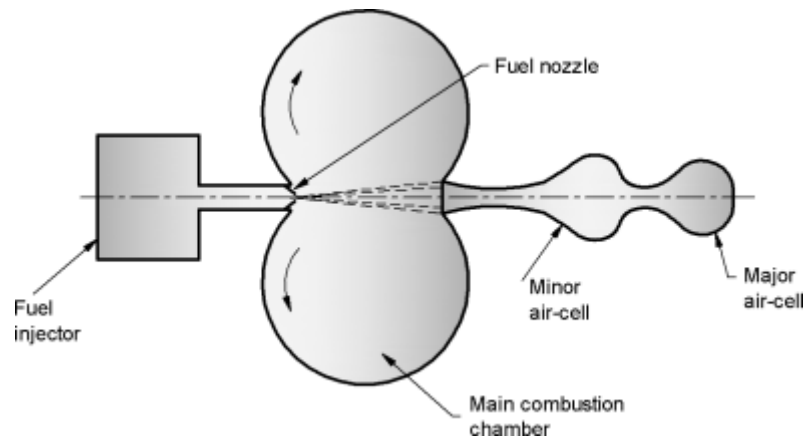

*Fig.7. 29 Air cell combustion chamber for Lanova engine (plan view)*

- The combustion is initiated in the air cell and due to high pressure rise it flows back into main chamber.
- The main combustion chamber is so designed that the gas stream from air-cell splits into two vertices to create high swirl.
- High turbulence and high temperature of gases reduce the delay period and it controls the rate of pressure rise and the engine runs smooth.
- This design differs from pre-combustion chamber in respect of fuel injection.
- In case of air cell the fuel is injected in the main chamber while in the other case into pre-combustion chamber.

### Advantages:

1. Cold starting of the engine is easier.
2. Due to high rate of swirl better mixing of air and fuel can be achieved which improves the combustion.
3. Exhaust emissions is less.
4. As maximum pressure rise is low, engine runs smoothly.

### Disadvantages:

1. Low thermal efficiency.
2. Higher fuel consumption (high bsfc).
3. Cannot be used for variable speed engine.

## Tutorial Questions

|    |   |
|----|---|
| 1  | State and explain different combustion stages in SI engine?                                     |
| 2  | State and explain different combustion stages in CI engine?                                     |
| 3  | Explain knocking, properties and its effects in CI engine?                                      |
| 4  | Explain different types of combustion chambers in SI and CI engines?                            |
| 5  | Explain the need for air motion and types?  |
| 6  | Factors influencing knocking in SI and CI engine?   |
| 7  | Differentiate between normal combustion and abnormal combustion phenomena in case of SI Engine. |
| 8  | What is the importance of variables like flame speed flame front in case of delay period.       |
| 9  | Explain knocking additives.   |
| 10 | Discuss air flow movements in CI engines  |

## Assignment Questions

|   |   |
|---|---|
| 1 | Explain the Splash lubrication system with the diagram?                           |
| 2 | Explain the carburetor working principle with diagram?                            |
| 3 | What are the types of fuel injection systems? Explain any one with a neat sketch? |
| 4 | How to tell a two stroke cycle engine from a 4 stroke cycle engine?               |
| 5 | Explain the Pressure feed system with a diagram?                                  |



---

# UNIT 3

## TESTING & PERFORMANCE

---





# Measurement and Testing of IC engines

---



## ***Course Contents***

- 9.1. Introduction
- 9.2. IS Standard Code 10000 to 10004 for Testing of Engines
- 9.3. Indicated Power (I.P.)
- 9.4. Measurement of Brake Power (B.P.)
- 9.5. Friction power
- 9.6. Fuel measurement
- 9.7. Measurement of Air Consumption
- 9.8. Measurement of Speed
- 9.9. Heat Balance Sheet or Energy Balance
- 9.10. Variables Affecting Engine Performance
- 9.11. Methods of Improving Engine Performance
- 9.12. Performance Characteristics of an Engine
- 9.13. Variable compression ratio (VCR) engine

## 9.1 Introduction

- The basic task in the design and development of I.C.Engines is to reduce the cost of production and improve the efficiency and power output. In order to achieve the above task, the engineer has to compare the engine developed by him with other engines in terms of its output and efficiency.
- Hence he has to test the engine and make measurements of relevant parameters that reflect the performance of the engine. In general the nature and number of tests to be carried out depend on a large number of factors. In this chapter only certain basic as well as important measurements and tests are described.

### Objectives

- With the development of internal combustion and their testing procedures, an Engineer's task is to reduce the cost and increase the power output and the efficiency of the engine. The aims of the engine testing are:
  1. To get the specified information which cannot be possibly determined by calculation.
  2. To justify the rating of the engine and the guaranteed specific fuel consumption.
  3. To verify and confirm the validity of engine data used in designing the engine i.e. to confirm that the actual performance matches with the design specifications.
- The BIS has published IS 14599(1999) as the standard for engine testing for determination of power, specific fuel consumption and smoke capacity (for CI. engine). The Indian standards for measurement of smoke IS 8118 (1998) and IS 14553 (1998) may be referred.

### Important performance parameters of ic engine

- Important performance parameters of ic engine are as follow:
  - i. Friction power
  - ii. Indicated power
  - iii. Brake power
  - iv. Fuel consumption
  - v. Air flow
  - vi. Speed
  - vii. Exhaust and coolant temperature
  - viii. Emissions
  - ix. Noise

## 9.2 IS Standard Code 10000 to 10004 for Testing of Engines

- IS standard code 10000 (Part I to Part XI) to 10004 specifies the Indian standards for testing of vehicles.

Table 9. 1 IS Standard Code

| <i>IS Code</i> |          | <i>Details</i>  |
|----------------|----------|---|
| IS : 10000     | Part I   | Glossary of terms related to test methods   |
|                | Part II  | Standard reference conditions   |
|                | Part III | Measurements for testing, units and limit of accuracy                                       |
|                | Part IV  | Declarations of power, efficiency specific fuel consumption and lubricating oil consumption |

|            |           |   |
|------------|-----------|---|
|            | Part V    | Preparation for tests and measurement for wear  |
|            | Part VI   | Recording of test results   |
|            | Part VII  | Governing test for constant speed engines. Also, the selection of engine for use with electrical generators.  |
|            | Part VIII | Performance test  |
|            | Part IX   | Endurance test procedures both for constant speed and variable speed engines. It is performed after tests specified in part VIII Endurance test for constant speed engines is carried and for 32 cycles in which each cycle is of 16 hrs continuous running. Before start of next cycle the temperature of oil sump is brought down to within 5°C of its initial temperature.<br>Endurance test for variable speed engines is conducted for 10 cycles (100 hrs) in which each cycle is of 10 hrs with interval of 2 hrs between cycles 10 hrs duration is divided into 5 cycles of each 2 hr duration.<br>Results obtained are corrected to standard reference conditions and compared to results of part VI above. |
|            | Part X    | Test for smoke levels for variable speed engines.   |
| IS 10000   | Part XI   | Information supplied by manufacturer test certificates  |
| IS : 10001 |           | Deals with specification for performance requirements for constant speed diesel engines up to 20 kW capacity.   |
| IS : 10002 |           | Same as above but for engines above 20 kW capacity  |
| IS : 10003 |           | Deals with specification for performance requirement of variable speed diesel engine for automotive purposes.   |
| IS : 10004 |           | Specifications for performance requirement for variable speed spark ignition (S.I) engines for automotive purposes.   |

### 9.3 Indicated Power (I.P.)

- The indicated power of an engine is the power developed within the cylinder. In order to determine the indicated power it is necessary to plot (p-V) diagram representing the actual conditions of the engine within the cylinder since the area of (p-V) diagram gives the work developed by the engine per cycle.
- Knowing the speed and type of engine the rate of work developed can be evaluated.
- The apparatus used for drawing actual (p-V) diagram is called engine indicator shown in Fig. 9.1.
- In order to estimate the indicated power of an engine the following methods are usually followed.
  1. Using the indicator diagram
  2. By adding two measured quantities viz. brake power and friction power
  3. From morse test
- Engine indicator consists of a cylinder, piston and piston rod. On the cylinder a coupling nut is fitted.
- The coupling nut is connected to a gas hole tap which is fitted to the cylinder head of the engine to be tested.

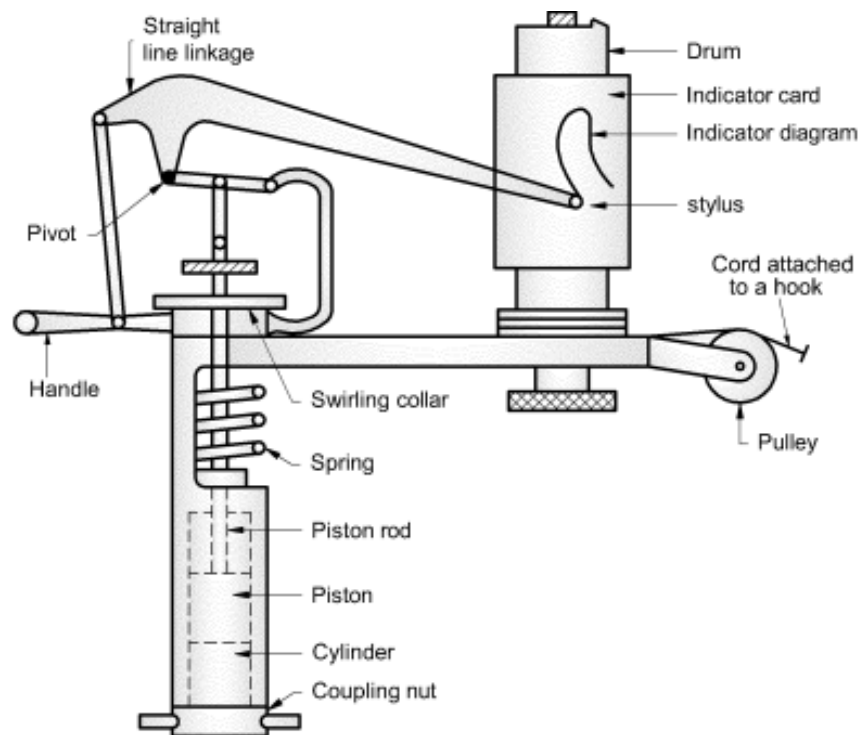

*Fig. 9. 1 Engine indicator (Mechanical type)*

- The gas tap connects through passages both to the cylinder of indicator and to the combustion chamber of the engine cylinder.
- The piston slides in the cylinder and the piston rod is connected to straight line linkage through a spring of proper stiffness.
- The straight line linkage is mounted on a swinging collar which can rotate on the top of the indicator cylinder.
- The spring controls the movement of the piston according to the pressure of engine cylinder.
- A stylus (pencil) is attached at the end of straight line linkage so that it moves in a vertical line in proportion to the movement of piston by magnifying its movement.
- A drum, to which a paper or indicator card can be fixed, is mounted on a vertical spring and shaft. It is rotated by a cord wound round it, the other end of which is attached to a point on the engine whose motion is same as that the piston of the engine cylinder.
- The vertical movement of the stylus and the horizontal movement of the cord combines to produce a closed figure known as indicator diagram.
- The area enclosed on the indicator diagram measures the work developed during a stroke to a definite scale.
- It should be noted that the stiffness of the spring is chosen appropriate to the maximum pressure in the cylinder.
- These type of indicators are not suitable for measurement in case of high speed engines due to its mechanical nature. Usually, these are found suitable up to a speed of 1500 r.p.m.

## Indicated Mean Effective Pressure (I.M.E.P.)

- It represents that constant pressure which if it is acted over the full length of the stroke would produce the same amount of work done by the piston as is actually produced by the engine cylinder during a cycle.

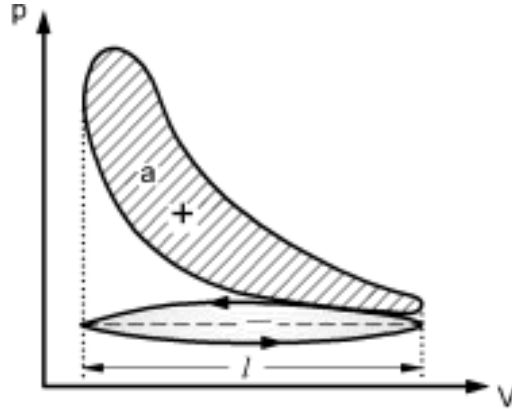

Fig. 9. 1 Indicator diagram

- i.m.e.p. can be determined with the help of indicator diagram shown in Fig. 9.2. The area of indicator diagram can be measured with the help of planimeter.

Let,  $a$  = Net area of indicator diagram ( $\text{cm}^2$ )  
 $l$  = Length of indicator diagram (cm)  
 $K$  = Spring constant,  $\text{N/cm}^2 / \text{cm}$

Therefore,

$$\text{Mean height of diagram} = \frac{a}{l}$$

$$\text{i. m. e. p.} = \frac{a}{l} \times K \text{ (N/cm}^2\text{)}$$

## Indicated power (I.P.):

Let,  $p_m$  = Indicated mean effective pressure ( $\text{N/cm}^2$ )  
 $A$  = Cross – sectional area of piston ( $\text{cm}^2$ ) =  $\frac{\pi}{4}(d)^2$

Where,

$d$  = Diameter of piston or bore (cm)  
 $L$  = Length of stroke (m)  
 $n$  = Number of power strokes per minute  
 $N$  = Speed of the engine (r.p.m.)  
 $n$  = Power stroke /min  
 =  $N/2$  for 4 S engine as one power stroke per 2 rev &  
 =  $N$  for 2S engine

Force on piston =  $p_m \times A$  (Newtons)

Work done per cycle =  $(p_m \times A) L$  (Nm)

$$\text{I.P.} = p_m A L n \text{ (Nm / min)}$$

$$\text{I.P.} = p_m A L \frac{n}{60} \text{ (Nm/s or W)}$$

$$\text{I.P.} = \frac{p_m A L n}{60000} \text{ (kW)}$$

## 9.4 Measurement of Brake Power (B.P.)

- Measurement of brake power is an important test carried out in the test schedule of an engine.
- It involves the determination of the torque and the angular speed of the engine output shaft. The torque measuring device is called a dynamometer.

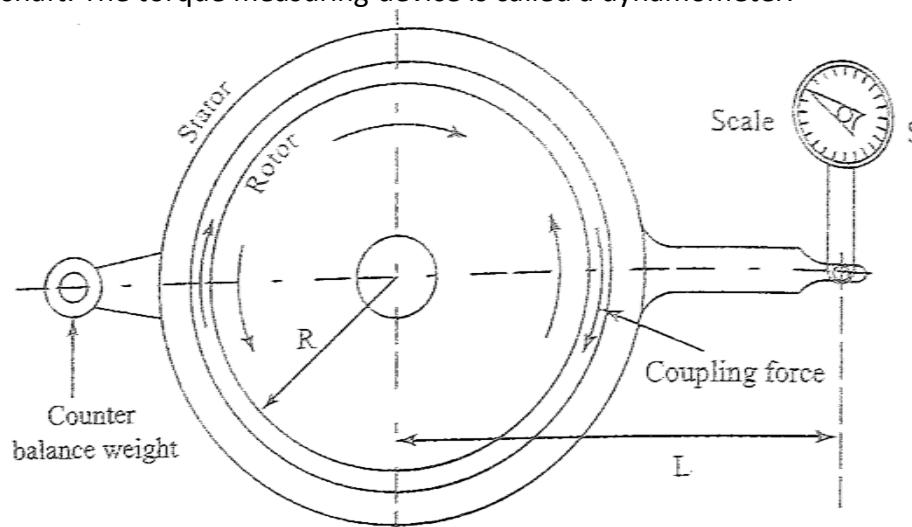

Fig. 9. 2 Principle of a dynamometer

- Figure shows the basic principle of a dynamometer. A rotor driven by the engine under test, is mechanically, hydraulically or electromagnetically coupled to a stator. For every revolution of the shaft, the rotor periphery moves through a distance  $2\pi R$  against the coupling force,  $F$ . Hence the work done per revolution is

$$W = 2\pi R F$$

- The external moment or torque is equal to  $S \times L$ , where  $S$  is the scale reading and  $L$  is the arm length. This moment balances the turning moment  $R \times F$ , i.e.,

$$S \times L = R \times F$$

Therefore

$$\text{Work done/revolution} = 2\pi S L$$

$$\text{Work done/minute} = 2\pi S L N$$

- Hence brake power is given by

$$bp = 2\pi N T \text{ Watts}$$

Where,  $T$  is the torque and  $N$  is rpm.

## Classification of dynamometers

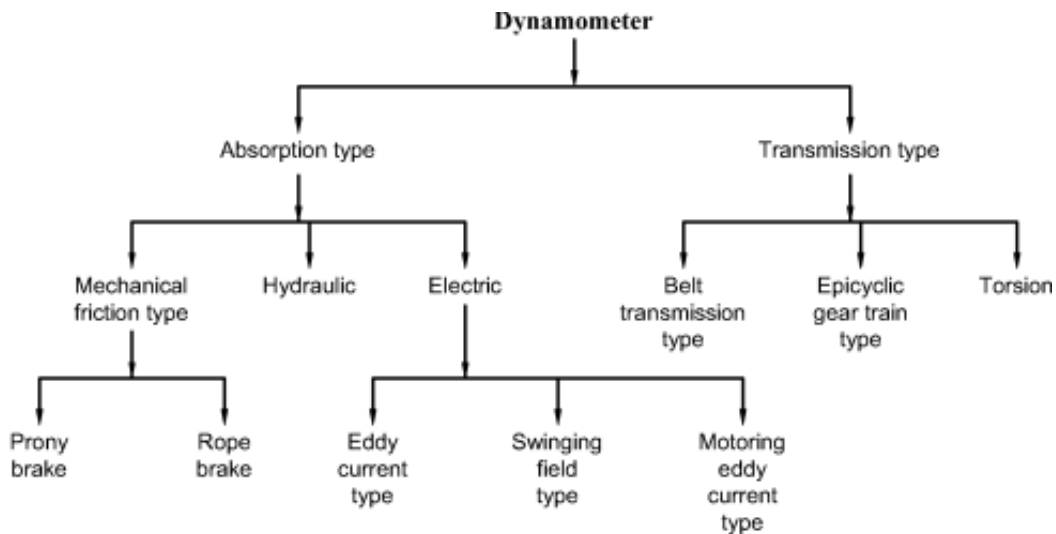

### 1. Prony Brake Dynamometer:

- One of the simplest methods of measuring power output of an engine is to attempt to stop the engine by means of a mechanical brake on the flywheel and measure the weight which an arm attached to the brake will support, as it tries to rotate with the flywheel. This system is known as the prony brake and from its use, the expression brake power has come. The prony brake consists of a frame with two brake shoes gripping the flywheel

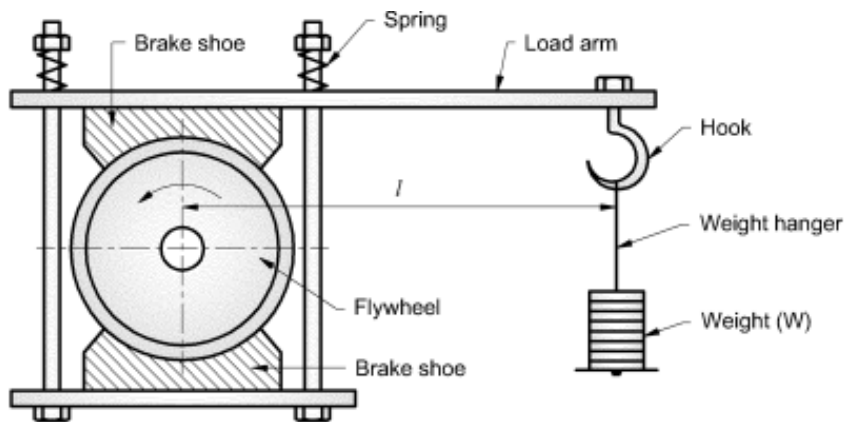

*Fig. 9. 3 Prony Brake Dynamometer*

- The pressure of the brake shoes on the fly wheel can be varied by the spring loaded using nuts on the top of the frame. The wooden block when pressed into contact with the rotating drum opposes the engine torque and the power is dissipated in overcoming frictional resistance. The power absorbed is converted into heat and hence this type of dynamometer must be cooled.

Let,  $W$  = Weight on hanger (N)

$L$  = Distance from centre to flywheel to the hanger called load arm (m)

$N$  = Speed (rpm)

Torque =  $W \times L$

$$B.P. = \frac{(W \times L)2\pi N}{60000} \text{ kW}$$

## 2. Rope brake Dynamometer:

- The rope brake as shown in Fig. is another simple device for measuring  $b_p$  of an engine. It consists of a number of turns of rope wound around the rotating drum attached to the output shaft.
- One side of the rope is connected to a spring balance and the other to a loading device. The power absorbed is due to friction between the rope and the drum. The drum therefore requires cooling.

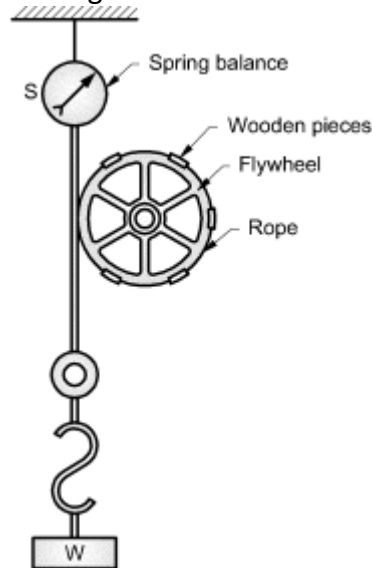

Fig. 9. 4 Rope Brake Dynamometer

- Rope brake is quite cheaper and can be easily fabricated but not very accurate because of changes in the friction coefficient of the rope with temperature.

Let,  $W$  = Dead weight (Newtons)

$S$  = Spring balance reading (Newtons)

$R_b$  = Radius of brake drum or flywheel (effective) =  $\frac{D + d}{2}$

Where,  $D$  = Brake drum diameter, and

$d$  = Rope diameter

$N$  = Speed in r.p.m.

Brake load or net load =  $(W - S)$

Braking torque =  $(W - S) R_b$

$$\text{Brake Power} = \frac{(W - S) R_b \times 2\pi N}{60000} \text{ kW}$$

- With the help of brake power, the brake mean effective pressure (b.m.e.p.) can be calculated from the following equation,

$$\text{Brake Power} = \frac{(b_{mep})ALn}{60000} = \frac{(P_{mb})ALn}{60000} \text{ kW}$$

## 3. Hydraulic Dynamometer:

- The hydraulic dynamometer was developed by Froude in 1877. This dynamometer is useful for measuring brake power over wide range of power and speeds.
- These are accurate, simple in construction, and free from vibration and maintenance.

- Fig. shows the part of a hydraulic dynamometer. It consists of a shaft supported in shaft bearings. The casing is carried by the anti-friction trunions so that it is free to swirl about the same axis as the axis of the shaft.
- The shaft carries a rotor in the form of semi-elliptical cross-section divided one from another by means of oblique vanes.
- The internal faces of the casing are provided with liners which are pocketed in the same way.

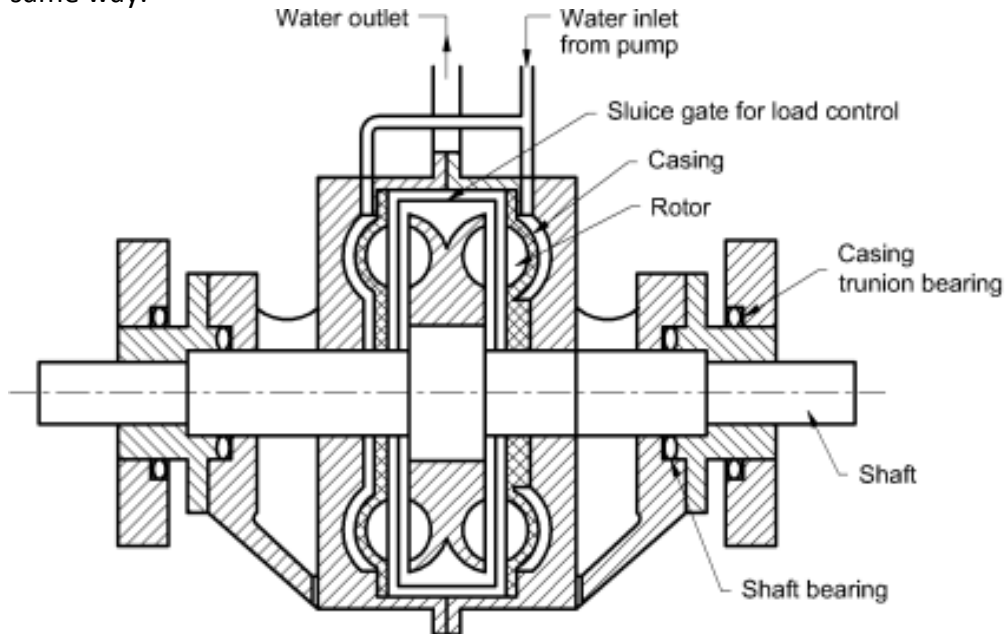

*Fig. 9. 5 Hydraulic Dynamometer*

- The pockets in rotor and liners together form an elliptical receptacles round which the water runs across at high speed.
- The engine shaft is directly coupled to dynamometer shaft. The water is circulated to the rotor to provide the hydraulic resistance and it carries away the heat developed due to absorption of power by water.
- The water is discharged from the rotor at high speed from its periphery into pockets formed in by the casing liners, by which it is then returned at diminished speed into rotor pockets near the shaft.
- The output can be controlled by controlling the sluice gates which can be moved in and out partially or fully to obstruct the flow of water between the rotor and casing.
- The resistance offered to motion of rotor reacts on the casing which tends to turn on its antifriction roller supports. This tendency is countered by means of a lever arm carrying weight 'W' which measures the torque.

$$\text{Brake Power} = \frac{W \cdot N}{K}$$

Where,            W = weight on lever arm (N)  
                       N = speed (r.p.m.)  
                       K = dynamometer constant

#### 4. Swinging Field Dynamometer:

- This type of dynamometer is usually used to measure brake power of high speed engines. It consists of an electric generator with its field system mounted on the trunions.
- The casing of the generator can revolve due to unbalancing of the applied and reactive torques.
- The torque supplied to the field of the dynamometer and the reaction of the electromagnetic induction on frame causes it to revolve about its shaft.
- This is counterbalanced by applying the external dead load or by the spring force.
- The speed of rotation is measured.
- The product of the applied external load, the load arm and the speed will give the power transmitted.

#### 5. Eddy Current Dynamometer:

- Fig. represents the principle of working of an eddy current dynamometer. It consists of a rotor disc made of steel or copper. The rotor shaft is supported in the bearings and it is coupled to the engine shaft.
- Its stator is fitted with a number of electromagnets and the stator cradles in the trunion bearing.
- When the rotor rotates, it produces the eddy currents in the stator due to magnetic flux set up by the passage of field current in the electromagnets.

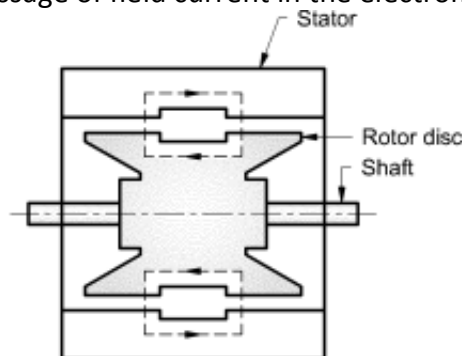

*Fig. 9. 6 Eddy current dynamometer*

- These eddy currents oppose the rotor motion, thus loading the engine.
- The torque is measured with the help of torque arm and the load as in the other types of dynamometers explained above.
- This dynamometer also requires to be provided with some cooling arrangement since the produced eddy currents are dissipated in producing heat.

#### Advantages of eddy current dynamometer:

1. It can measure high power output at all speeds therefore, these are suitable to test automobile and aircraft engines.
2. Its size is small compared to other dynamometers.
3. The torque developed is smooth and continuous under all operating conditions.
4. These dynamometers can be produced in all sizes for measurement of power.

## 6. Transmission Dynamometer

- Transmission dynamometers, also called torque meters, mostly consist of a set of strain gauges fixed on the rotating shaft and the torque is measured by the angular deformation of the shaft which is indicated as strain of the strain gauge. Usually a four-arm bridge is used to reduce the effect of temperature to minimum and the gauges are arranged in pairs such that the effect of axial or transverse load on the strain gauges is avoided.
- Figure shows a transmission dynamometer which employs beams and strain-gauges for a sensing torque.

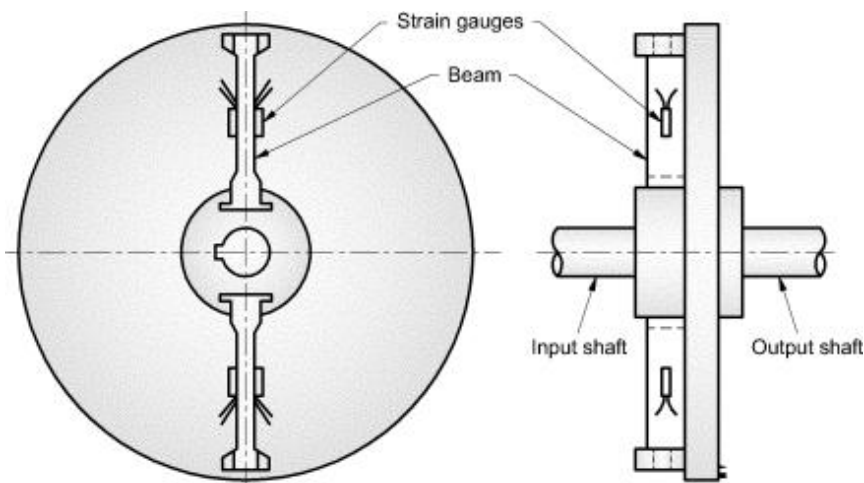

*Fig. 9. 7 Transmission dynamometers*

- Transmission dynamometers are very accurate and are used where continuous transmission of load is necessary. These are used mainly in automatic units.

## 9.5 Friction power

- The difference between the indicated and the brake power of an engine is known as friction power. The internal losses in an engine are essentially of two kinds, viz., pumping losses and friction losses. During the inlet and exhaust stroke the gaseous pressure on the piston is greater on its forward side (on the underside during the inlet and on the upper side during the exhaust stroke), hence during both strokes the piston must be moved against a gaseous pressure and this causes the so called pumping loss.
- The friction loss is made up of the friction between the piston and cylinder walls, piston rings and cylinder walls, and between the crankshaft and camshaft and their bearings, as well as by the loss incurred by driving the essential accessories, such as the water pump, ignition unit etc.
- It should be the aim of the designer to have minimum loss of power in friction. Friction power is used for the evaluation of indicated power and mechanical efficiency. Following methods are used to find the friction power to estimate the performance of the engine.
  1. Willan's line method
  2. Morse test
  3. Motoring test
  4. From the measurement of indicated and brake power

## 5. Retardation test

### 1. Willan's line method

- In Willan's line method, gross fuel consumption vs. BP at a constant speed is plotted and the graph is extrapolated back to zero fuel consumption as illustrated in Figure. The point where this graph cuts the BP axis is an indication of the friction power of the engine at that speed. This negative work represents the combined loss due to mechanical friction, pumping and blow by.
- In petrol engine, we keep the air-fuel mixture constant and vary the amount of the mixture intake for required torque or power. This is called quantitative governing. In diesel engine, we draw a constant volume of air (compressed) and vary the fuel injected. Technically, we alter the quality of the air - fuel mixture, this is called qualitative governing.
- In SI engine, at low speeds, the air mixture intake is very low (quantitative governing). Hence, there will be a low pressure region created inside the cylinder due to which, there will be pumping losses. Therefore, there will be more friction power than actual, we get erroneous output if we use Willan's line test for SI engine.
- If we use the same test for CI engines, there is qualitative governing and hence, there will be fixed amount of air entering the cylinder and no negative pressure and pumping losses occurs. So, we get a relatively closer value of friction power, the errors are greatly minimized.
- So, Willan's line method is applicable only to Diesel (C.I) engines.

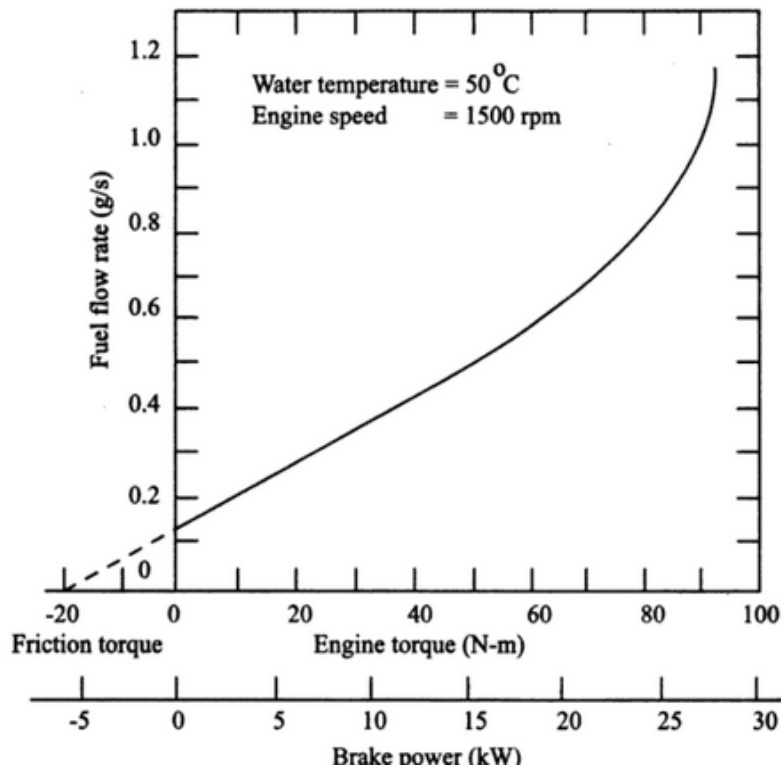

Fig. 9. 8 Willan's line method

- The main drawback of this method is the long distance to be extrapolated from data measured between 5 and 40% load towards the zero line of fuel input.
  1. The directional margin of error is rather wide because of the graph which may not be a straight line many times.

2. The changing slope along the curve indicates part efficiencies of increments of fuel. The pronounced change in the slope of this line near full load reflects the limiting influence of the air-fuel ratio and of the quality of combustion.
3. Similarly, there is a slight curvature at light loads. This is perhaps due to difficulty in injecting accurately and consistently very small quantities of fuel per cycle.
4. Therefore, it is essential that great care should be taken at light loads to establish the true nature of the curve.
5. The Willan's line for a swirl-chamber CI engine is straighter than that for a direct injection type engine.
6. The accuracy obtained in this method is good and compares favorably with other methods if extrapolation is carefully done.

## 2. Morse test

- The indicated power (ip) of multi cylinder engine can be found out by this method, is not possible to find ip for single cylinder that is the limitation of this method. Also, in the method the indicator or indicator diagram is not required. For multi cylinder engine, power developed in any one cylinder is cut off and output power (bp) is measured. In case of petrol (S.I.) engines, each cylinder in turn is rendered inoperative by shorting the spark plug of the cylinder and in case of diesel (C.I.) engines by cutting off the fuel supply to cylinders successively.
- Consider a four cylinder spark ignition engine coupled to a dynamometer. Throughout the test the engine is run at constant speed of N r.p.m. It is assumed that the pumping and mechanical friction losses are the same whether the cylinder is working or not. Also, the throttle position is kept constant throughout the test.
- Let :
  - B = B.P. of the engine when all the four cylinders are working
  - $B_1$  = B.P. of the engine when cylinder - 1 is cut - off
  - $B_2$  = B.P. of the engine when the cylinder - 2 is cut-off
  - $B_3$  = B.P. of the engine when cylinder - 3 is cut-off
  - $B_4$  = B.P. of the engine when cylinder - 4 is cut-off.

$I_1, I_2, I_3$  and  $I_4$  be the indicated power (I.P.) developed by cylinder numbers 1, 2, 3 and 4 respectively and their corresponding friction power (F.P) be  $F_1, F_2, F_3$  and  $F_4$ .

$$\text{Total brake power (B)} = (I_1 + I_2 + I_3 + I_4) - (F_1 + F_2 + F_3 + F_4)$$

$$B_1 = (I_2 + I_3 + I_4) - (F_1 + F_2 + F_3 + F_4)$$

On subtracting Equation

$$B - B_1 = I_1$$

Similarly, we could write the equations when the other cylinders are cut-off in turn as follows:

$$B - B_2 = I_2$$

$$B - B_3 = I_3$$

$$B - B_4 = I_4$$

On adding Equations

$$\text{Total indicated power, } I = I_1 + I_2 + I_3 + I_4 = 4B - (B_1 + B_2 + B_3 + B_4)$$

$$\text{Frictional power, } F = I - B$$

$$\text{F.P.} = \text{I.P.} - \text{B.P}$$

### Errors involved in measurement of F.P. by Morse Test:

- Though the measurement of frictional power is fairly accurate, however, the errors involved in measurement of F.P. by this method are :
- 1. In petrol engines using common intake manifolds may affect the distribution of mixture and the volumetric efficiency of each cylinder.
- 2. The use of common exhaust manifolds and the cutting off the cylinders may cause pulsations in the exhaust system, which in turn will affect the performance of the engine.

### 3. Motoring Test:

- In motoring test method of determining the frictional power, the engine is run up to its rated power till steady state conditions are reached. The power developed by engine is absorbed by a swinging field dynamometer connected to engine shaft. Either the ignition of a petrol engine or the fuel supply of a diesel engine, as the case may be, is then cut-off.
- By suitable changes in electric switching devices, the dynamometer is run as a motor at the same speed at which the engine was run.
- The output of the motor is measured which would represent the frictional power losses of the engine. In order to maintain the operating temperatures of the engine, the cooling water system is also cut-off during the motoring test.
- Errors involved in measurement of F.P. by motoring test:
- However, the motoring test does not give the true friction losses at the test speed and load for the following reasons :
  1. Temperatures during the motoring test are lower than those in a firing engine due to cooling by the incoming air and heat transfer to the surroundings.
  2. Reduced temperatures reduces the lubricating oil temperatures and increases oil viscosity, therefore, it increases friction power.
  3. The pressure and load on bearings and piston rings are lower than firing engine, it reduces frictional power.
  4. The clearance between piston and cylinder is more due to reduced temperatures in the cylinder. It reduces the friction losses.
  5. Friction power is also affected due to air being drawn at a temperature lower than firing engine since it is not heated from cylinder walls.
  6. Back pressure is more than the firing engine since after expansion, the required pressure difference is not available to impart kinetic energy to expel the exhaust gases.
- However, motoring test gives fairly good results since the increased and reduced friction losses almost balance each other.
- This method is very useful for finding the friction losses caused by various components by progressively stripping off the engine component for research purposes.

### 4. From the Measurement of Indicated and Brake Power

- This is an ideal method by which  $f_p$  is obtained by computing the difference between indicated power obtained from an indicator diagram and brake power obtained by a dynamometer. This method is mostly used only in research laboratories as it is

necessary to have elaborate equipment to obtain accurate indicator diagrams at high speeds.

## 5. Retardation Test

- This test involves the method of retarding the engine by cutting the fuel supply. The engine is made to run at no load and rated speed taking into all usual precautions. When the engine is running under steady operating conditions the supply of fuel is cut-off and simultaneously the time of fall in speeds by say 20%, 40%, 60%, 80% of the rated speed is recorded. The tests are repeated once again with 50% load on the engine. The values are usually tabulated in an appropriate table. A graph connecting time for fall in speed (x-axis) and speed (y-axis) at no load as well as 50% load conditions is drawn as shown in Fig.

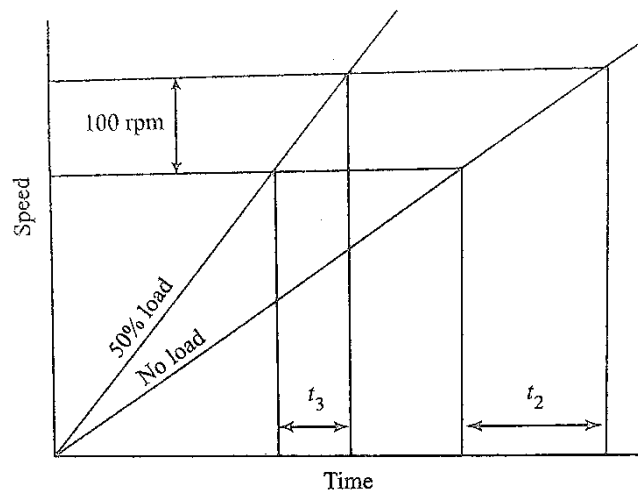

Fig. 9. 9 Graph for Retardation Test

- From the graph the time required to fall through the same range (say 100 rpm) in both, no load and load conditions are found. Let  $t_2$  and  $t_3$  be the time of fall at no load and load conditions respectively. The frictional torque and hence frictional power are calculated as shown below. Moment of inertia of the rotating parts is constant throughout the test.

$$\text{Torque} = \text{Moment of Inertia} \times \text{Angular Acceleration}$$

- Let  $\omega$  be the angular velocity and  $\frac{d\omega}{dt}$  be the angular acceleration.

$$T = I \frac{d\omega}{dt}$$

$$\text{But, } I = MK^2$$

$$\therefore T = MK^2 \frac{d\omega}{dt}$$

$$d\omega = \frac{T}{MK^2} dt$$

- Now integrating between the limits  $\omega_1$  and  $\omega_2$  for time  $t_1$  and  $t_2$ ,

$$\int_{\omega_1}^{\omega_2} d\omega = \frac{T}{MK^2} \int_{t_1}^{t_2} dt$$

$$\therefore (\omega_2 - \omega_1) = \frac{T}{MK^2} (t_2 - t_1)$$

- Let  $T_f$  be the friction torque and  $T_l$  the load torque. At no load the torque is only friction torque  $T_f$  and at load the torque is  $T_f + T_l$ . Hence at no load

$$\therefore (\omega_2 - \omega_1) = \frac{T_f}{MK^2} (t_2 - 0)$$

- The reference angular velocity  $\omega_0$  is that at, say 1000 rpm, the time of fall for the same range at load

$$\therefore (\omega_0 - \omega_1) = \frac{T_f + T_l}{MK^2} (t_3 - 0)$$

$$(T_f + T_l)t_3 = T_f t_2$$

$$\frac{t_2}{t_3} = \frac{(T_f + T_l)}{T_f} = 1 + \frac{T_l}{T_f}$$

$$\frac{T_l}{T_f} = \frac{t_2}{t_3} - 1 = \frac{t_2 - t_3}{t_3}$$

$$\therefore T_f = T_l \left( \frac{t_3}{t_2 - t_3} \right)$$

- $T_l$  is the load torque which can be measured from the loading  $t_2$  and  $t_3$  are observed values. From the above  $T_f$  can be calculated and there by the friction power.

### Comparison of Various Methods

- The Willan's line method and Morse tests are comparatively easy to conduct. However, both these tests give only an overall idea of the losses whereas motoring test gives a very good insight into the various causes of losses and is a much more powerful tool.
- As far as accuracy is concern, the ip – bp method is the most accurate, if carefully done. Motoring methods usually gives a higher value for fp as compared to that given by the Willan's line method. Retardation method, though simple, require, accurate determination of the load torque and the time for the fall in speed for the same range.

## 9.6 Fuel Measurement

- Fuel consumption of an engine may be expressed either in terms of volume or mass of fuel supplied in a specified time. The two basic types of fuel measurement are :
  - Volumetric type flow meters
  - Gravimetric type flow meters

### 1. Volumetric Type Fuel Flow meter:

- A simple arrangement for measurement of fuel supply in laboratory is shown in Fig. It consists of two spherical shells of 100 cc and 200 cc capacity.

- These are connected to two-three way cocks so that one spherical shell feeds the engine while the other is filled from the fuel tank.
- The time required to feed the given volume of fuel is noted.

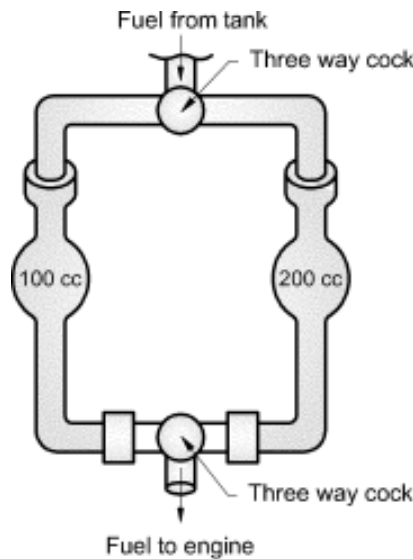

*Fig. 9. 10 Volumetric Type Fuel Flow meter*

- The mass flow rate of fuels supply is,  

$$m_f = \frac{\text{Volume}}{\text{Time}} \times \text{Density of fuel}$$
- Where, density of fuel  $\rho_f = \text{Specific gravity of fuel} \times \text{density of water } \rho_w$   
(But,  $\rho_w = 1000 \text{ kg / m}^3$  )
- The disadvantage of this method is that it does not give exact mass flow rate due to variation in density with temperature.

## 2. Gravimetric Fuel Flow meter:

- Fig. shows the arrangement for direct measurement of the mass of fuel supplied.
- When the measurement of fuel supply is not required, the valve B is closed and the valve A is kept open so that the fuel from fuel tank is directly supplied to the engine.
- When the measurement of fuel flow is required, both the valves A and B are kept open. The quantity of fuel in flask is weighed on the balance.
- After this the valve A is closed and the valve B is kept open so that the fuel from flask flows into engine and the time is measured.
- The quantity of fuel in the flask is again weighed. In this way the mass flow rate of fuel supplied to the engine can be determined.

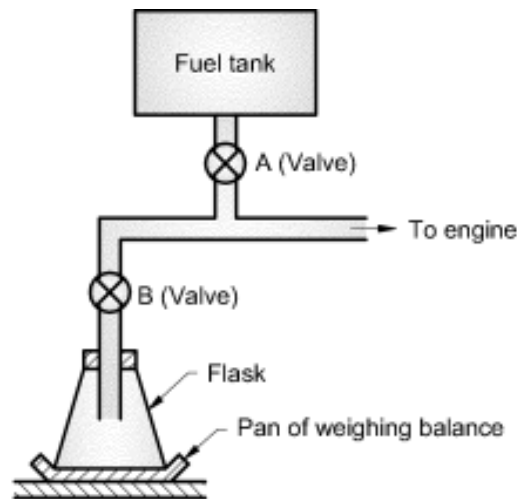

Fig. 9. 11 Direct weighing of fuel flow

## 9.7 Measurement of Air Consumption

### 1. Air Flow Meter:

- The air flow meter is shown in Fig. for measurement of air consumption in a laboratory. It consists of a surge tank of capacity (400-600) times to the displacement volume of the engine so as to reduce pulsations. The surge tank is connected to the intake side of the engine with an orifice of cross-sectional area  $A$  and of known coefficient of discharge  $C_d$ .
- The pressure difference causing the air flow is measured with the help of a water manometer.
- Let  $(\Delta H)_w$  be the pressure difference measured in cm of water and  $(\Delta H)_{air}$  the corresponding pressure difference in cm of air. Based on unit area of manometer, the head in terms of meters of air is given by,

$$(\Delta p) = (\Delta H)_w \times 1 \times \rho_w = (\Delta H)_{air} \times 1 \times \rho_{air}$$

$$(\Delta H)_{air} = \frac{\rho_w}{\rho_{air}} \times (\Delta H)_w$$

where ,  $\rho_w = 1000 \text{ kg / m}^3$

- The volume flow rate of air is given by,

$$V = C_d \times A \times \sqrt{2g(\Delta H)_{air}}$$

$$V = C_d \times A \times \sqrt{2g \frac{\rho_w}{\rho_{air}} \times (\Delta H)_w}$$

$$m_{air} = V \cdot \rho_a$$

$$m_{air} = C_d \times A \times \sqrt{2g \cdot \rho_w \cdot \rho_a (\Delta H)_w}$$

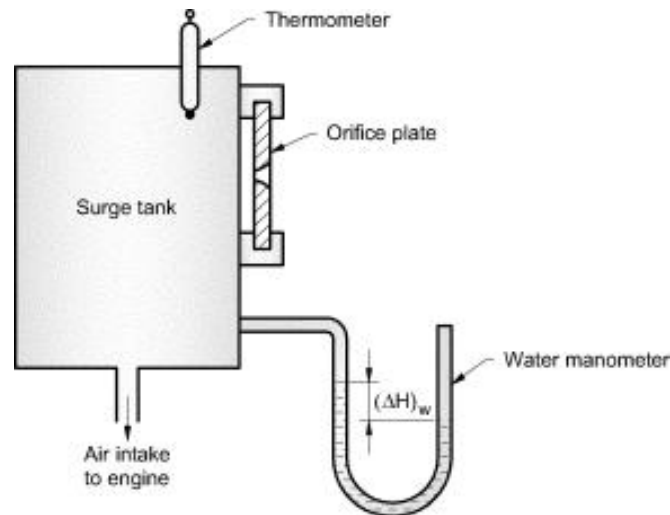

Fig. 9. 12 Air flow meter

## 2. Viscous Air Flow Meter:

- For accurate measurement of air flow, Alcock viscous air flow meter is shown in Fig.
- This meter uses an element where viscous resistance is the principal source of pressure loss with negligible kinetic effects. Therefore, it gives a linear relationship between the flow and the pressure drop.
- The air is passed through the air filter so as to remove any contamination in it.
- The air now passes over the viscous element consisting of very large number of passages in the form of honeycomb; each passage being triangular size (0.5 mm × 0.5 mm × 75 mm approx.)
- The pressure drop is measured with the help of a manometer.
- Felt pads are fitted in the manometer connections to damp out fluctuations.

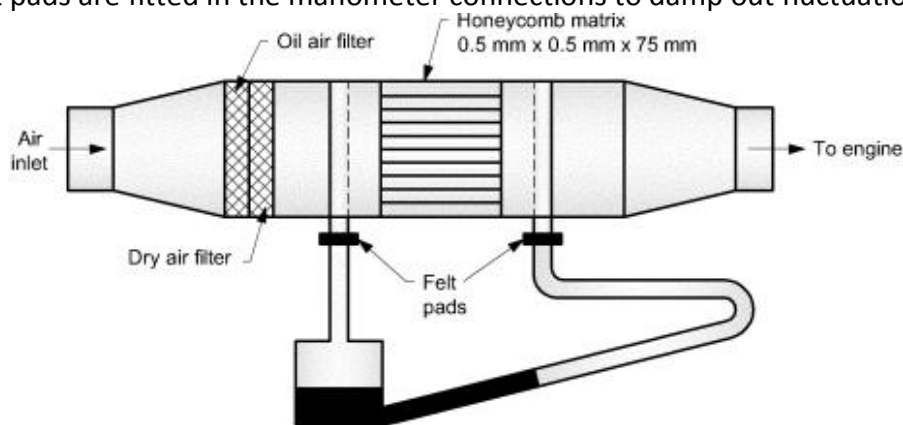

Fig. 9. 13 Alcock viscous air flow meter

## 9.8 Measurement of Speed

- The speed of the engine can be measured with the help of tachometers (mechanical or electrical), mechanical counters and timers, stroboscope, electronic pulse counters etc. However, mechanical and electrical tachometers are affected by the temperature variation and they are not very accurate.
- For accurate and continuous measurement of speed a magnetic pick up placed near a toothed wheel coupled to the engine shaft can be used. The magnetic pick up will

produce a pulse every revolution and a pulse counter will measure the speed accurately.

## 9.9 Heat Balance Sheet or Energy Balance

- Heat balance sheet represents an account of the heat supplied in fuel and released in combustion and its utilization in the engine. Necessary information concerning the performance of the engine is obtained from the heat balance sheet.
- In order to draw a heat balance sheet, a complete test on the engine must be carried out while the engine is run at constant load.
- Heat supplied: Energy is supplied to the engine in the form of fuel supplied to the engine, its heat being released during combustion.

$$\text{Heat supplied} = m_f \times C.V. \text{ (kJ/min)}$$

Where,

$m_f$  = mass flow rate of fuel (kg/min)

C.V. = Calorific value of fuel in kJ/kg

Heat expenditure / Heat utilised:

- Heat energy of the fuel is partly converted into useful work equivalent to its B.P. and the remainder is carried away by cooling water, exhaust gases and some of heat is lost in radiation, incomplete combustion, lubricating oil, which remains unaccounted for.

**Note:** Frictional power is not accounted in the heat calculations since friction work is converted into heat which in turn is transferred partly to cooling water and remainder is carried away by exhaust gases.

Calculations for expenditure of heat are as follows:

a) Heat equivalent to B.P.:

- Heat equivalent to brake power per min = B.P.  $\times$  60 (kJ/min)

b) Heat rejected to cooling water:

- Heat carried away by cooling water per minute

$$= m_w \times C_{pw} \times (t_{wo} - t_{wi})$$

Where,

$m_w$  = mass of cooling water circulated in kg/min

$C_{pw}$  = specific heat of water = 4.187 kJ/kg K

$t_{wi}$  = cooling water inlet temperature ( $^{\circ}$ C)

$t_{wo}$  = cooling water outlet temperature ( $^{\circ}$ C)

Heat carried away by exhaust gases:

- Heat carried away by exhaust gases per minute

$$= m_g \times C_{pg} \times (t_g - t_o)$$

Where,

$m_g$  = mass flow of flue or exhaust gases (kg/min)

$m_g$  = mass flow rate of air  $m_a$  + mass flow rate of fuel  $m_f$

$C_{pg}$  = specific heat of gases

$t_g$  = temperature of exhaust gases ( $^{\circ}$ C)

$t_o$  = room temperature ( $^{\circ}$ C) or surrounding temperature

## Heat balance sheet

Table 9. 2 Heat balance sheet

| Heat supplied   | kJ/min   | %           | Heat Expenditure   | kJ/min   | %           |
|---|----------|-------------|--|----------|-------------|
| Heat supplied by<br>Combustion of<br>fuel = $\dot{m}_f \times C.V.$ | –        | 100         | (a) Heat in B.P. = B.P. $\times$ 60  | –        | –           |
|   |          |             | (b) Heat rejected to cooling water<br>= $\dot{m}_w \times C_{pw} \times (t_{c2} - t_{c1})$ | –        | –           |
|   |          |             | (c) Heat carried away by exhaust<br>gases = $\dot{m}_g \times C_{pg} \times (t_g - t_0)$   | –        | –           |
|   |          |             | (d) Heat unaccounted due to<br>radiation etc. (by difference)                              | –        | –           |
| <b>Total</b>  | <b>–</b> | <b>100%</b> | <b>Total</b>   | <b>–</b> | <b>100%</b> |

### 9.10 Variables Affecting Engine Performance

- Important variables which affect the engine performance are as follows:

#### 1. Compression ratio:

- The increase in compression ratio increases the thermal efficiency of the engine. However, increased C.R. ratio increases the pressure and temperature which results into higher friction losses of the engine.
- Moreover, increased C.R. tends to increase detonation in S.I. engines. Thus the C.R. is limited to a certain value for better performance.

#### 2. Air-fuel ratio:

- Lean mixtures are used for economic running of the engine while the stoichiometric air-fuel ratios are used for development of maximum power and during acceleration of the engine.

#### 3. Rate of combustion and ignition timing:

- In case of S.I. engines the igniting timings are adjusted to provide the combustion rates such that the maximum pressure occurs to the beginning of power stroke i.e. at T.D.C. for smooth running of the engine.
- In case of C.I. engines, the fuel injection is so timed that it provides the half of total pressure rise during combustion almost near to TDC. For optimum performance.

#### 4. Engine speed:

- Increase in speed of the engine, increases the mass flow rate of air. It increases the power output. However, the increased speeds also increase the friction losses.
- Thus the optimum of the engine should be adjusted so as to provide the optimum performance.

#### 5. Mass of intake charge and supercharging of engines:

- Higher the mass flow rates will provide better volumetric efficiency and power output. Mass flow rates can be improved by supercharging the engine.

- But in case of S.I. engines, the supercharging is not employed due to increased tendency of detonation whereas of supercharged C.I. engines run smooth.

## 9.11 Methods of Improving Engine Performance

- Basically, the engine performance can be improved either by increasing the energy input to the engine or by improving the conversion efficiency of engine, following methods are suggested to improve the engine performance:
  1. By increasing mass flow rate of mixture.
  2. Supercharging the engine.
  3. Use of larger piston diameters.
  4. Use of fuels of higher calorific value.
  5. Increased engine speeds.
  6. By improving its volumetric efficiency by reducing pressure losses in intake manifolds and reducing the mixture flow restrictions.
  7. Use of higher compression ratios.
  8. Use of fuel additives, exhaust gas recirculation, positive crankcase ventilation etc.
  9. Reduction in heat losses.

## 9.12 Performance Characteristics of an Engine

- Engine Performance Characteristics are the Graphical Representation of Engine Performance.
- Laboratory tests are performed to determine I.P., B.P., mechanical efficiency, thermal efficiency and specific fuel consumption. The performance characteristics of S.I. and C.I. engines are being discussed below.

### 1. S.I. Engines:

- Fig. 9.14 (a), (b) and (c) represent the performance characteristic curves for a variable speed S.I. engine.
- At full load the throttle is kept wide open and the speed is varied by adjusting the brake load.
- The I.P., B.P. and fuel consumptions are measured as discussed earlier. Similar tests can be carried out at half load by changing the brake load to half of full load at the same speed.
- It can be observed that the I.P. increases when i.m.e.p or the speed or both of them increase.
- The I.P. increases first with the increase in speed if the inlet conditions are kept constant.
- However, after certain limit the rate of increase of I.P. is reduced with increase in speed because of drop in pressure at intake and reduction in volumetric efficiency.
- Mechanical losses increase with increase in speed due to which the increase in I.P. is offset by the increased losses; therefore, the mechanical efficiency reduces with increase in speed as shown in Fig. (b).

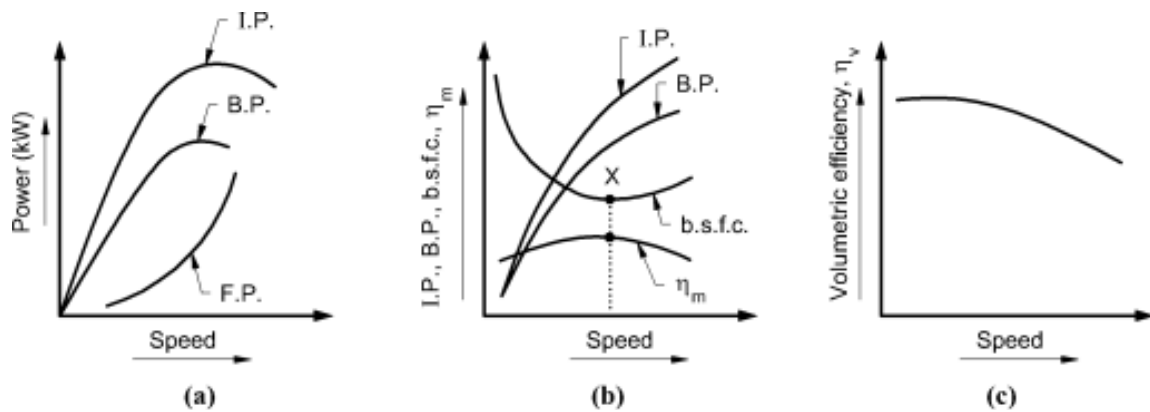

Fig. 9.14 Performance curve for S.I. engine

- The effect on brake specific fuel consumption (b.s.f.c.) with variation in speed is also represented in Fig. (b). At low speeds with increase in speed the b.s.f.c. reduces since the volumetric efficiency and mechanical efficiency are high.
- After certain speed the b.s.f.c. increases because of reduction in volumetric efficiency and increased mechanical losses.
- Point-X represents the economical speed for minimum fuel consumption for the engine.
- Fig.(c) shows the variation of volumetric efficiency with speed. The volumetric efficiency reduces with the increase in speed because of drop in pressure at suction caused by increase in velocity of charge to be inducted.
- The suction valve will only open when pressure inside the cylinder is slightly below the surrounding pressure, thus the effective suction stroke is reduced.
- It reduces the volume of mixture inducted lowering the volumetric efficiency.

## 2. C.I. Engines:

- Fig. 9.15 shows the performance curves for C.I. engine at various speeds.
- Fig. 9.15 shows the variation of brake fuel consumption Vs B.P. for S.I. and C.I. engines when run at constant speed.
- The test is carried out by keeping the speed constant and by varying the throttling from no load to maximum load in case of S.I. engines or by varying the fuel supply in case of C.I. engines.

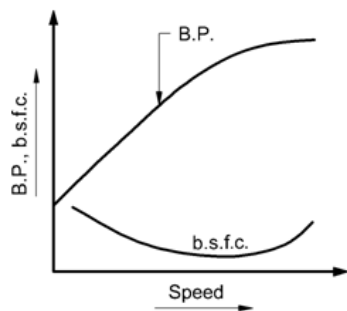

Fig. 9.15 Performance curve for C.I. engine

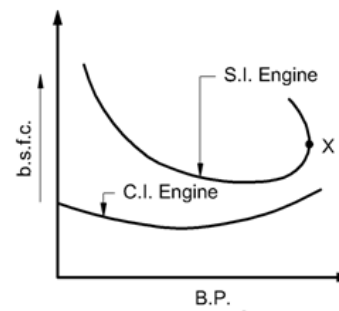

Fig. 9.16 Performance curve for S.I. and C.I. engine at constant speed

- It could be seen that in case of S.I. engines the b.s.f.c. first decreases with increase in load while working at part loads upto a certain minimum value and then it starts increasing rapidly with further increase in loads.

- Beyond full load the curve starts forming a loop backward beyond point - X which shows that the output decreases but the fuel consumption increases. It is due to the fact that the mixture supplied to the engine is too rich and lot goes as unburnt in the exhaust.
- Such a condition of the engine is called choking. In case of C.I. engines the b.s.f.c. Vs B.P. curve is more uniform and the specific fuel consumption is lower than S.I. engines.

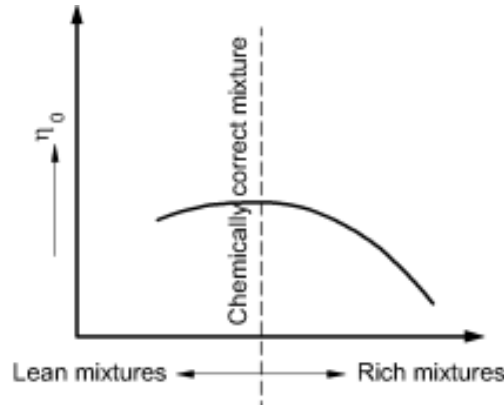
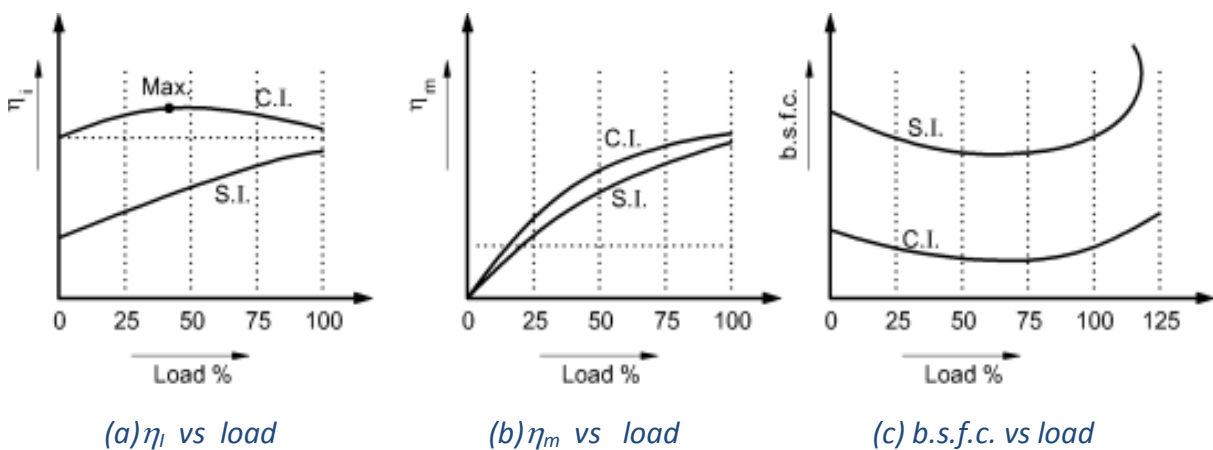

Fig. 9.17 Brake thermal Vs Mixture strength

- It shows that the thermal efficiency of C.I. engine is higher than that of the S.I. engine and the specific fuel consumption in case of C.I. engines is not much affected with variation in load on the engine.
- Fig. 9.20 shows the performance curve between brake or overall thermal efficiency ( $\eta_0$ ) and mixture strength.
- It shows that with slightly weak mixtures the thermal efficiency is maximum since the fuel supplied will be utilised to maximum extent.
- While the efficiency is low with very lean mixtures because of lower maximum temperatures attained after combustion and also the efficiency is low with rich mixtures due to incomplete combustion of fuel.

### 3. Effect of Load on Different Engine Parameters:

- The engine speed of an engine is maintained constant with the help of governor and the load on the engine is varied. The variation of indicated thermal efficiency, mechanical efficiency and brake specific fuel consumption vs percentage of load on the engine is shown in Fig. 9.18(a), 9.18(b) and 9.18(c) respectively.



(a)  $\eta_i$  vs load

(b)  $\eta_m$  vs load

(c) b.s.f.c. vs load

Fig. 9.18 Performance curves of S.I. and C.I. engines at constant speed

- The conclusions are as follows :
- a) **Indicated thermal efficiency:**
  - The indicated thermal efficiency increases with the increase in load for S. I. engines. While for C. I. engines, the indicated thermal efficiency first increases to maximum at about 40% of load and then decreases with increase in load as shown in Fig. 9.21(a).
- b) **Mechanical efficiency:**
  - Referring to Fig. 9.21(b), it is observed that the mechanical efficiency increases with load for both type of engines. Since friction power is less than the rate in increase in B. P. of the engine.
  - Mechanical efficiency of C. I. engine is more than the mechanical efficiency of S. I. engine at the same load since friction losses in C. I. engines are less compared to S. I. engines.
- c) **Brake specific fuel consumption:**
  - Referring to Fig. 9.21(c), it is observed that the b.s.f.c. reduces with load upto 70% to 80% of load since combustion is efficient but with further increase in load, the b.s.f.c. reduces since at higher loads the friction losses increase considerably. While in case of C. I. engines, the b.s.f.c. keeps on reducing upto 90% load.

#### 4. Comparison of Performance of S. I. and C. I. Engines:

- It should be noted that higher indicated mean effective pressure results into higher power developed for a given displacement. The comparison between S.I. and C.I. engines is given below.

Table 9. 3 Comparison

| Sr. No. | Aspect                         | S.I. Engine             | C.I. Engine  |
|---------|--------------------------------|-------------------------|--|
| (i)     | Power output/unit weight       | High                    | Low, since the base of high C.R. makes the engine heavy. |
| (ii)    | Acceleration                   | High due to low inertia | Low due to high inertia                                  |
| (iii)   | Power output/unit displacement | Low due to low C.R.     | High due to high C.R.                                    |

#### 5. Performance Maps:

- Major variables to evaluate the performance of an engine are :
  - i. Engine speed
  - ii. Brake power (B.P.) or load
  - iii. Piston speed
  - iv. Specific fuel consumption
- Therefore for the critical analysis of an I.C. engine under all conditions of load and speed, a set of curves can be drawn which are independent of the size of engine. Such a map of curves is called the performance map.
- These performance maps can be used to predict the performance of geometrically similar engines because the performance parameters are used in generalized form by converting rotational speed (N) into piston speed and power output as power output per unit area of the piston.

- The performance map of a S.I. engine is shown in Fig. 9.19.

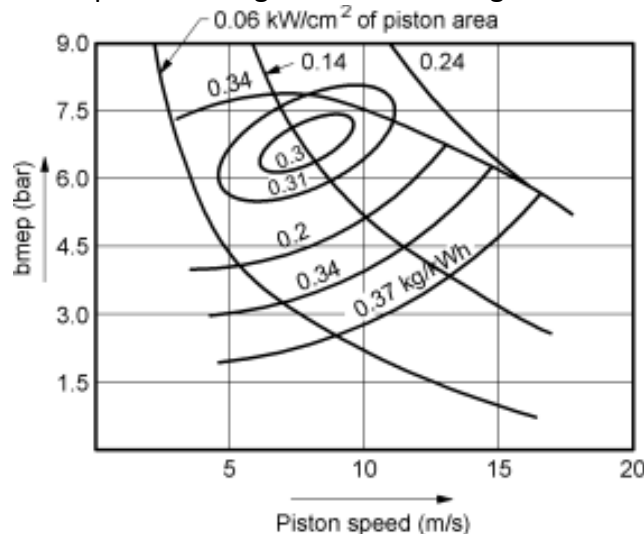

Fig. 9.19 Performance map of a S.I. engine

- The minimum consumption in kg/kWh shows the point of maximum efficiency. It could be seen from the map, it occurs at low piston speeds with high bmep.
- It is evident that b.s.f.c increases with decrease in bmep because of the reduced mechanical efficiency at low loads since the frictional mean effective pressure almost remains the same.
- Fig. 9.20 shows the performance map for a C.I. engine.

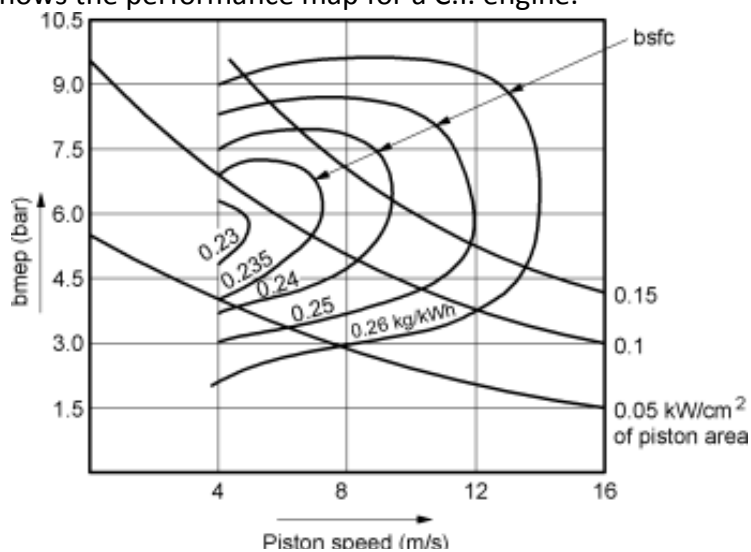

Fig. 9.20 Performance map of a C.I. engine

- Following observations can be made:
  - i. b.s.f.c increases with increase in bmep (i.e. due to increase in load). It is due to the fact that low A.F. ratio at high loads causes increased unburnt carbon. Whereas, the b.s.f.c also increases at low loads because of the decreased mechanical efficiency.
  - ii. Minimum b.s.f.c is attained at almost half the maximum bmep i.e. corresponding to its maximum power.

### 9.13 Variable compression ratio (VCR) engine

- One of the successful methods of improving the specific output of the engine is the use of VCR engine. It can solve the problem of high peak pressures by reducing the

compression ratio (C.R.) at full loads by allowing the turbocharger to boost the intake pressures and thus increasing the specific output. While at low and part loads the specific power output can be increased by use of high compression ratios.

- *Therefore, a VCR engine can improve the specific power output by use of low C.R. at full loads and by use of high C.R. at part loads without facing the problem of peak pressures.*
- The concept of VCR engine can be used both for S.I. and C.I. engines. But this concept is more suitable for C.I. engines since,
  - i. The part load efficiency of a C.I. engine is higher than S.I. engine and the concept of VCR is beneficial at part loads only.
  - ii. Diesel engines have better multi fuel capabilities.
  - iii. It is believed that the variable C.R. may cause detonation problems in case of S.I. engines in a short period of time.

### 1. Methods of Obtaining Variable Compression Ratio:

- Variable compression ratio in an engine can be obtained by the following methods:
  1. By changing the clearance volume. In this method the compression ratio is changed by lowering or raising the piston crown.
  2. By changing both the clearance volume and the stroke length. This method requires a variable throw crankshaft for changing the stroke length.

Various mechanisms for VCR engines are:

- i. Fig. 9.21(a) shows a mechanism in which the stroke length is changed according to load on the engine. Such a mechanism being too complex, this method is not generally adopted in practice.

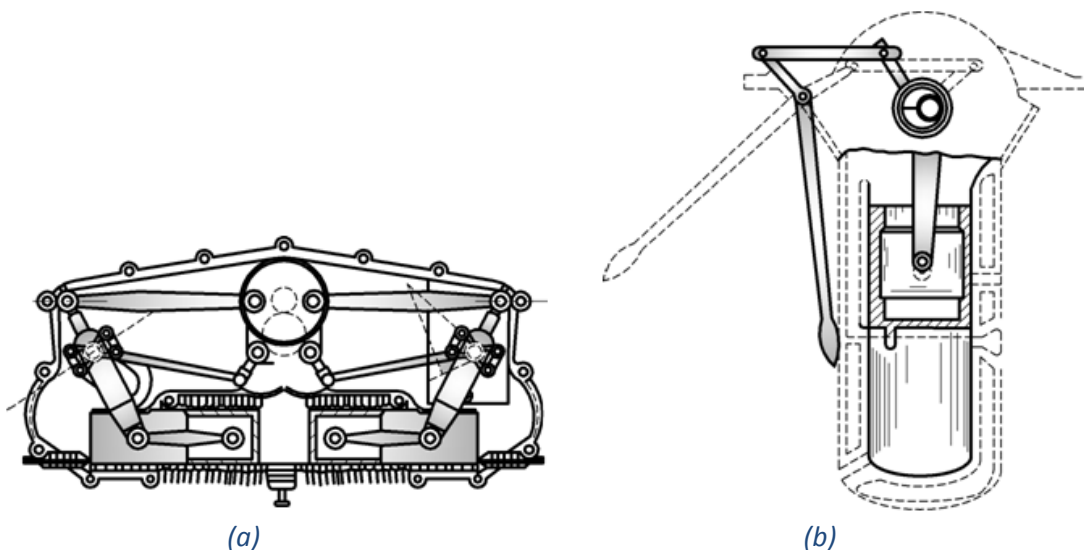

(a)  
 Fig. 9. 21 (a) VCR engine by changing the stroke length  
 (b) Variman VCR engine using movement of crank shaft

- ii. Fig. 9.21(b) shows a mechanism for variable compression ratio as developed by Tecquiment Ltd. (U.K.) which uses the movement of the crankshaft for varying the compression ratio in the range or 4.5: 1 to 20: 1.
  - In this system, the crankshaft and the main bearing assembly is carried in a cradle having two forged transverse members, its ends are connected by hollow pins on each side of the crankshaft and in parallel direction to it.

- The cradle swings about one of the pivot formed by these pins and the other pivot is used for adjustment. The adjustment rod has an eye at its lower end carrying the hollow pin and its upper end is threaded to take a nut in the form of a worm wheel.
  - In case the worm wheel is rotated, the crankshaft and its main bearings move up and down thus changing the clearance volume and thus affecting the compression ratio as mentioned above.
- iii. The most promising VCR mechanism is as adopted and developed by British Internal Combustion Engine Research Institute (BICERI) as shown in Fig. 9.22. The mechanism uses a special piston to lower or raise the piston skirt.
- The mechanism consists of two main parts A and B called shell and carrier respectively. The carrier B is mounted on the gudgeon pin and the shell A slides on the carrier B. The movement of the shell causes the change in clearance volume, hence changes the compression ratio.
  - Parts A and B form two chambers C and D which are kept full by lubricating oil supplied through the hole provided in the connecting rod and a non-return valve F from the lubricating system.

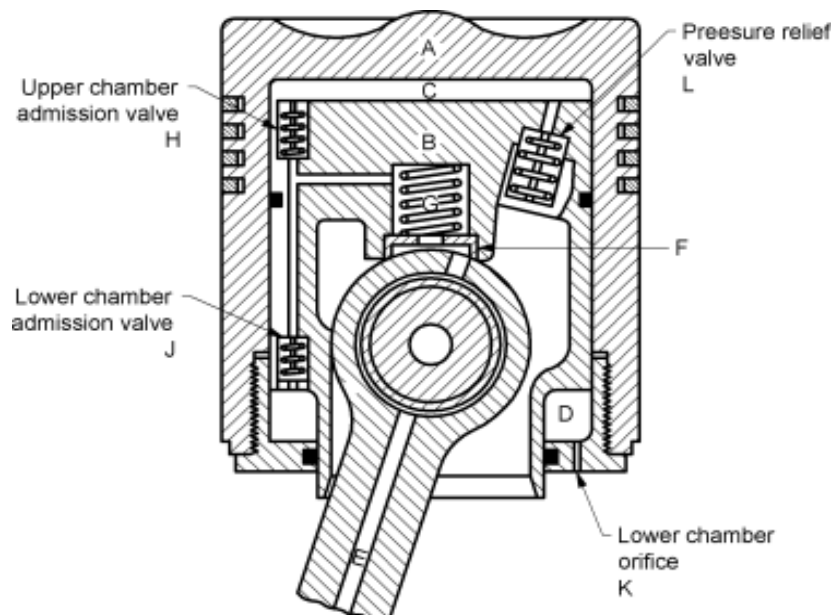

*Fig. 9. 22 VCR engines developed by BICERI*

- The gas loads on the piston is carried by the lubricating oil in the chamber C. This gas pressure increases with the increase in load on the engine. When gas pressure exceeds the designed value, the spring loaded relief valve L opens and discharges oil to the main sump. The piston shell A will slide down upto a position decided by the relationship between the oil pressure in two chambers and the cylinder gas pressure. Therefore, this movement of the shell will affect the change in C.R. of the engine.

## 2. Performance of VCR Engine:

### 1. Power output

- When VCR and fixed C.R. engines were tested of the same size at same speed it was observed that :
  - i. b.m.e.p. and power output is high.
  - ii. b.s.f.c. remains the same.

iii. Weight to power ratio reduces considerably.

## 2. Thermal loads

- With VCR engine as per the load on the engine, the duration of heat released is decreased. It leads to smooth combustion both at low and high compression ratios.
- The low C.R. at high loads provides the following advantages :
  - i. Reduction in combustion chamber temperatures.
  - ii. Maximum pressure decreases and the ignition lag increases.
  - iii. Volumetric efficiency increases.
- Above points leads to overall decrease in thermal loads in VCR engines.

## 3. S.f.c.

- The reduced compression ratio at high loads decreases the thermal efficiency of the engine with increase in specific fuel consumption (sfc). However, these effects are counter balanced by the following factors.
  - i. F.P. remains constant irrespective of loads against the increased F.P. in case of fixed C.R. engines with increase in loads on the engine.
  - ii. Lower rate of expansion permits the better combustion of fuel because of availability of sufficient time for combustion.

## 4. Engine noise

- Noise from engines depend on the peak pressure in the cylinder and the rate of pressure rise. The peak pressures affect the lower frequency noise and the rate of pressure rise affects the high frequency noise. Therefore, VCR engines are more silent compared to fixed C.R. engines since the VCR engines have lower peak pressures which remain constant irrespective of the load on the engine.

## 5. Cold starting and idling

- Since VCR engine works at high compression ratio at low loads, it has very good starting and idling performance at low ambient temperatures.

## 6. Multifuel capability

- It has good Multifuel capability particularly in case of opposed piston engine type engine since it operates at higher C.R. at low and part loads.

\*\*\*\*\*

*“If you want to walk fast then walk alone but if you want to walk far then walk together.”*

## Tutorial Questions

|    |  |
|----|--|
| 1  | Explain the Morse test ?   |
| 2  | What is wilan's line .how do you measure frictional power using this.                  |
| 3  | Discuss different types of dynamometers.   |
| 4  | Write short notes on Exhaust gas analysis  |
| 5  | Derive volumetric efficiency of air compressor   |
| 6  | Classify compressors   |
| 7  | Explain Isothermal work done   |
| 8  | Derive equation for workdone of reciprocating air compressor with T-S and p-V diagrams |
| 9  | Explain about intercooling   |
| 10 | Explain multistage compression   |

## Assignment Questions

|   |  |
|---|--|
| 1 | What is the significance of heat balance sheet? Discuss the procedure to draw heat balance sheet for CI engine?      |
| 2 | Define the following terms: Indicated Power, Brake power, Friction Power, Mechanical efficiency, Mean effectiveness. |
| 3 | Explain the working principle of reciprocating compressor with a neat sketch.  |
| 4 | Explain the work required for Multi-stage compressor?  |
| 5 | What is the condition for maximum efficiency in multistage compression?  |



---

# UNIT 4

## RECIPROCATING & ROTARY COMPRESSORS

---





## AIR COMPRESSORS

---

### 4.1 Introduction:

Compression of air and vapour plays an important role in engineering fields. Compression of air is mostly used since it is easy to transmit air compared with vapour.

### 4.2 Uses of compressed air:

The applications of compressed air are listed below:

- 1) It is used in gas turbines and propulsion units.
- 2) It is used in striking type pneumatic tools for concrete breaking, clay or rock drilling, chipping, caulking, riveting etc.
- 3) It is used in rotary type pneumatic tools for drilling, grinding, hammering etc.
- 4) Pneumatic lifts and elevators work by compressed air.
- 5) It is used for cleaning purposes
- 6) It is used as an atomiser in paint spray and insecticides spray guns.
- 7) Pile drivers, extractors, concrete vibrators require compressed air.
- 8) Air-operated brakes are used in railways and heavy vehicles such as buses and lorries.
- 9) Sand blasting operation for cleaning of iron castings needs compressed air.
- 10) It is used for blast furnaces and air-operated chucks.
- 11) Compressed air is used for starting I.C.engines and also super charging them.

### 4.3 Working principle of a compressor:

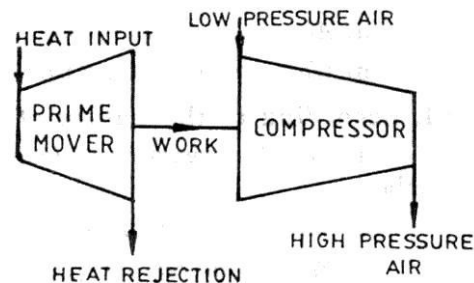

**Fig:4.1 Air Compressor**

A line diagram of a compressor unit is shown in fig:4.1. The compression process requires work input. Hence a compressor is driven by a prime mover. Generally, an electric motor is used as prime mover. Air from atmosphere enters into the compressor. It is compressed to a high pressure. Then, this high pressure air is delivered to a storage vessel (reservoir). From the reservoir, it can be conveyed to the desired place through pipe lines.

Some of the energy supplied by the prime mover is absorbed in work done against friction. Some portion of energy is lost due to radiation and coolant. The rest of the energy is maintained within the high pressure air delivered.

### 4.4 Classification of compressors:

Air compressors may be classified as follows:

According to design and principle of operation:

- (a) Reciprocating compressors in which a piston reciprocates inside the cylinder.
- (b) Rotary compressors in which a rotor is rotated.

According to number of stages:

- (a) Single stage compressors in which compression of air takes place in one cylinder only.
- (b) Multi stage compressors in which compression of air takes place in more than one cylinder.

According to pressure limit:

- (a) Low pressure compressors in which the final delivery pressure is less than 10 bar,
- (b) Medium pressure compressor in which the final delivery pressure is 10 bar to 80 bar and
- (c) High pressure compressors in which the final delivery pressure is 80 to 100 bar.

According to capacity:

- (a) Low capacity compressor (delivers  $0.15\text{m}^3/\text{s}$  of compressed air),
- (b) Medium capacity compressor (delivers  $5\text{m}^3/\text{s}$  of compressed air) and
- (c) High capacity compressor (delivers more than  $5\text{m}^3/\text{s}$  of compressed air).

According to method of cooling:

- (a) Air cooled compressor (Air is the cooling medium) *and*
- (b) Water cooled compressor (Water is the cooling medium).

According to the nature of installation:

- (a) Portable compressors (can be moved from one place to another).
- (b) Semi-fixed compressors and
- (c) Fixed compressors (They are permanently installed in one place).

According to applications:

- (a) Rock drill compressors (used for drilling rocks),
- (b) Quarrying compressors (used in quarries),
- (c) Sandblasting compressors (used for cleaning of cast iron) and
- (d) Spray painting compressors (used for spray painting).

According to number of air cylinders

- (a) Simplex - contains one air cylinder
- (b) Duplex - contains two air cylinders
- (c) Triplex - contains three air cylinders

**4.4.1 Reciprocating compressors** may be classified as follows:

- (a) Single acting compressors in which suction, compression and delivery of air (or gas) take place on one side of the piston.
- (b) Double acting compressors in which suction, compression and delivery of air (or gas) take place on both sides of the piston.

**4.5 Single stage reciprocating air compressor:**

In a single stage compressor, the compression of air (or gas) takes place in a single cylinder. A schematic diagram of a single stage, single acting compressor is shown in fig:4.2.

**Construction:** It consists of a piston which reciprocates inside a cylinder. The piston is connected to the crankshaft by means of a connecting rod and a crank. Thus, the

rotary movement of the crankshaft is converted into the reciprocating motion of the piston. Inlet and outlet valves (suction

and delivery valves) are provided at the top of the cylinder.

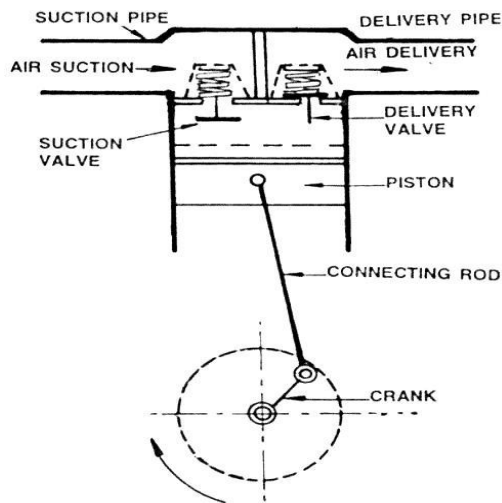

Fig :4.2 Single stage reciprocating Air Compressor

**Working:** When the piston moves down, the pressure inside the cylinder is reduced. When the cylinder pressure is reduced

below atmospheric pressure, the inlet valve opens. Atmospheric air is drawn into the cylinder till the piston reaches the bottom dead centre. The delivery valve remains closed during this period. When the piston moves up, the pressure inside the cylinder increases. The inlet valve is closed, since the pressure inside the cylinder is above atmospheric. The pressure of air inside the cylinder is increased steadily. The outlet valve is then opened and the high pressure air is delivered through the outlet valve in to the delivery pipe line.

At the top dead centre of the piston, a small volume of high pressure air is left in the clearance space. When the piston moves down again, this air is expanded and pressure reduces, Again the inlet valve opens and thus the cycle is repeated.

#### *Disadvantages*

1. Handling of high pressure air results in leakage through the piston.
2. Cooling of the gas *is not effective*.
3. Requires a stronger cylinder to withstand high delivery pressure.

Applications: It is used in places where the required pressure ratio is small.

#### **4.6 Compression processes:**

The air may be compressed by the following processes.

- (a) Isentropic or adiabatic compression,
- (b) Polytropic compression and
- (c) Isothermal compression

#### **(a) Isentropic(or)adiabatic compression:**

In internal combustion engines, the air (or air fuel mixture) is compressed isentropically. By isentropic compression, maximum available energy in the gas is obtained.

### (b) Polytropic compression:

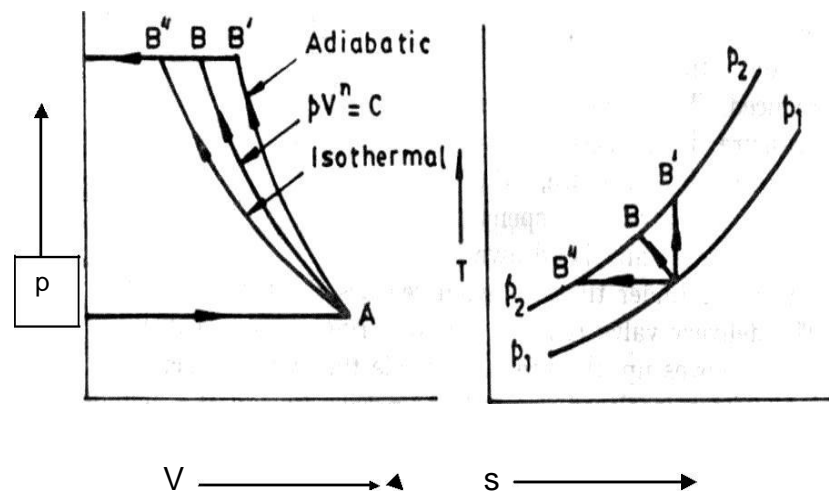

**Fig: 4.3 Compression processes**  
**A-B'' : Isothermal; A-B : Polytropic; A-B' : Isentropic**

The compression follows the law  $pV^n = \text{Constant}$ . This type of compression may be used in Bell-Coleman cycle of refrigeration.

### (c) Isothermal compression:

When compressed air (or gas) is stored in a tank, it loses its heat to the surroundings. It attains the temperature of surroundings after some time. Hence, the overall effect of this compression process is to increase the pressure of the gas keeping the temperature constant. Thus isothermal compression is suitable if the compressed air (or gas) is to be stored.

### 4.7 Power required for driving the compressor:

The following assumptions are made in deriving the power required to drive the compressor.

1. There is no pressure drop through suction and delivery valves.
2. Complete compression process takes place in one cylinder.
3. There is no clearance volume in the compressor cylinder.
4. Pressure in the suction line remains constant. Similarly, pressure in the delivery line remains constant.
5. The working fluid behaves as a perfect gas.
6. There is no frictional losses.

The cycle can be analysed for the three different case of compression. Work required can be obtained from the  $p - V$  diagram.

Let,

$p_1$  = Pressure of the air ( $\text{kN/m}^2$ ), before compression

$V_1$  = Volume of the air ( $\text{m}^3$ ), before compression

$T_1$  = Temperature of the air ( $K$ ), before compression

$p_2, V_2$  and  $T_2$  be the corresponding values after compression.

$m$  - Mass of air induced or delivered by the cycle (kg).

$N$  - Speed in RPM.

#### 4.7.1 Polytropic Compression

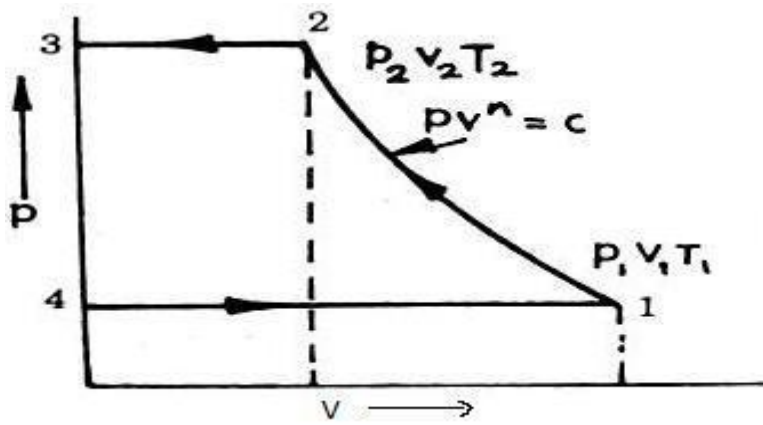

**Fig:4.4 Polytropic compression (Compression follows  $pV^n = \text{Constant}$ )**

Let  $n =$  Index of polytropic compression

Net work done on air/cycle is given by

$$W = \text{Area } 1-2-3-4-1$$

$=$  Work done during compression (1-2) + Work done during air delivery (2-3) - Work done during suction (4-1).

$$W = \frac{p_2 v_2 - p_1 v_1}{n-1} + p_2 v_2 - p_1 v_1$$

$$W = \frac{p_2 v_2 - p_1 + (n-1)p_2 v_2 - (n-1)p_1 v_1}{n-1}$$

$$= \frac{np_2 v_2 - np_1 v_1}{n-1} = \left(\frac{n}{n-1}\right) p_2 v_2 - p_1 v_1$$

We know that,  $p_1 V_1 = m R T_1$  &  $p_2 V_2 = m R T_2$

Therefore,  $W = \frac{n}{n-1} m R (T_2 - T_1)$

$$W = \frac{n}{n-1} m R T_1 \left[ \frac{T_2}{T_1} - 1 \right]$$

For polytropic process,  $\frac{T_2}{T_1} = \left(\frac{p_2}{p_1}\right)^{\frac{n-1}{n}}$

Therefore,  $W = \frac{n}{n-1} m R T_1 \left[ \left(\frac{p_2}{p_1}\right)^{\frac{n-1}{n}} - 1 \right]$  kJ/cycle

$$W = \frac{n}{n-1} p_1 V_1 \left[ \left(\frac{p_2}{p_1}\right)^{\frac{n-1}{n}} - 1 \right] \text{ kJ/cycle}$$

Indicated power (or) Power required,  $P = W \times N$ , kW for single acting reciprocating compressor;

$= W \times 2N$ , kW for double acting reciprocating compressor.

#### 4.7.2 Isentropic compression

### Compression follows, $pV^\gamma = \text{Constant}$

Let  $\gamma$  = Index of isentropic compression

Net work done on air/cycle is given by

$$W = \text{Area } 1-2-3-4-1$$

= Work done during compression (1-2) + Work done during air delivery (2-3) - Work done during suction (4-1).

$$W = \frac{p_2 v_2 - p_1 v_1}{\gamma - 1} + p_2 v_2 - p_1 v_1$$

$$W = \frac{p_2 v_2 - p_1 + (\gamma - 1) p_2 v_2 - (\gamma - 1) p_1 v_1}{\gamma - 1}$$

$$= \frac{\gamma p_2 v_2 - \gamma p_1 v_1}{\gamma - 1} = \left( \frac{\gamma}{\gamma - 1} \right) p_2 v_2 - p_1 v_1$$

We know that,  $p_1 V_1 = m R T_1$  &  $p_2 V_2 = m R T_2$

$$W = \frac{\gamma}{\gamma - 1} m R (T_2 - T_1)$$

$$W = \frac{\gamma}{\gamma - 1} m R T_1 \left[ \frac{T_2}{T_1} - 1 \right]$$

For isentropic process,  $\frac{T_2}{T_1} = \left( \frac{p_2}{p_1} \right)^{\frac{\gamma - 1}{\gamma}}$

Therefore,  $W = \frac{\gamma}{\gamma - 1} m R T_1 \left[ \left( \frac{p_2}{p_1} \right)^{\frac{\gamma - 1}{\gamma}} - 1 \right]$  kJ/cycle

$$W = \frac{\gamma}{\gamma - 1} p_1 V_1 \left[ \left( \frac{p_2}{p_1} \right)^{\frac{\gamma - 1}{\gamma}} - 1 \right]$$
 kJ/cycle

### 4.7.3 Isothermal Compression

Compression follows,  $pV = \text{Constant}$

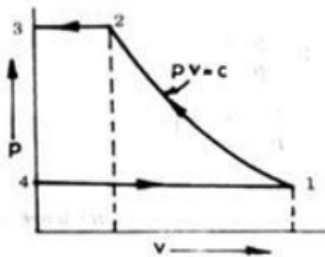

Fig: 4.5 Isothermal Compression

Isothermal Work input,  $W = \text{Area } 1-2-3-4-1 = \text{area under } 1-2 + \text{area under } 2-3 - \text{area under } 4-1$

$$W = p_1 V_1 \ln \left( \frac{V_1}{V_2} \right) + p_2 V_2 - p_1 V_1$$

$$\text{But } p_1 V_1 = p_2 V_2$$

$$W = p_1 V_1 \ln \left( \frac{V_1}{V_2} \right) \quad \text{and} \quad \frac{V_1}{V_2} = \frac{p_2}{p_1}$$

$$\text{Therefore, } W = p_2 V_2 \ln \left( \frac{p_2}{p_1} \right) \text{ kJ/cycle}$$

**4.8 Isothermal efficiency:** Isothermal efficiency is defined as the ratio of isothermal work input to the actual work input. This is used for comparing the compressors.

$$\text{Isothermal efficiency, } \eta_{\text{iso}} = \frac{\text{Isothermal work input}}{\text{Actual work output}}$$

**4.9 Adiabatic efficiency:** Adiabatic efficiency is defined as the ratio of adiabatic work input to the actual work input. This is used for comparing the compressors.

$$\text{Adiabatic efficiency, } \eta_{\text{adia}} = \frac{\text{Adiabatic work input}}{\text{Actual work output}}$$

#### 4.10 Mechanical efficiency:

The compressor is driven by a prime mover. The power input to the compressor is the shaft power (brake power) of the prime mover. This is also known as brake power of the compressor.

Mechanical efficiency is defined as the ratio of indicated power of the compressor to the power input to the compressor.

$$\eta_m = \frac{\text{Indicated power of compressor}}{\text{Power input}}$$

$$\text{Indicated Power, IP} = \frac{p_m l a N k}{60},$$

where,  $p_m$  = mean effective pressure, kN/m<sup>2</sup>

$l$  = length of stroke of piston, m

$a$  = area of cross section of cylinder, m<sup>2</sup>

$N$  = crank speed in rpm, and

$K$  = number of cylinders

#### 4.11 Clearance and clearance volume:

When the piston reaches top dead centre (TDC) in the cylinder, there is a dead space between piston top and the cylinder head. This space is known as clearance space and the volume occupied by this space is known as clearance volume,  $V_c$ .

The clearance volume is expressed as percentage of piston displacement. Its value ranges from 5% - 10% of swept volume or stroke volume ( $V_s$ ). The  $p$  -  $V$  diagram for a single stage compressor, considering clearance volume is shown in fig. . At the end of delivery of high pressure air (at point 3), a small amount of high pressure air at  $p_2$  remains in the clearance space. This high pressure air which remains at the clearance space when the piston is at TDC is known as remnant air. It is expanded polytropically till atmospheric pressure ( $p_4 = p_1$ ) is reached. The inlet valve is opened and the fresh air is sucked into the cylinder. The suction of air takes place for the rest of stroke (upto point 1). The volume of air sucked is known as effective suction volume ( $V_1 - V_4$ ). At point 1, the air is compressed polytropically till the delivery pressure ( $p_2$ ) is reached. Then the delivery valve is opened and high pressure air is

discharged into the receiver. The delivery of air continues till the piston reaches its top dead centre, then the cycle is repeated.

#### 4.11.1 Effect of clearance volume:

The following are the effects of clearance space.

1. Suction volume (volume of air sucked) is reduced.
2. Mass of air is reduced.
3. If clearance volume increases, heavy compression is required.
4. Heavy compression increases mechanical losses

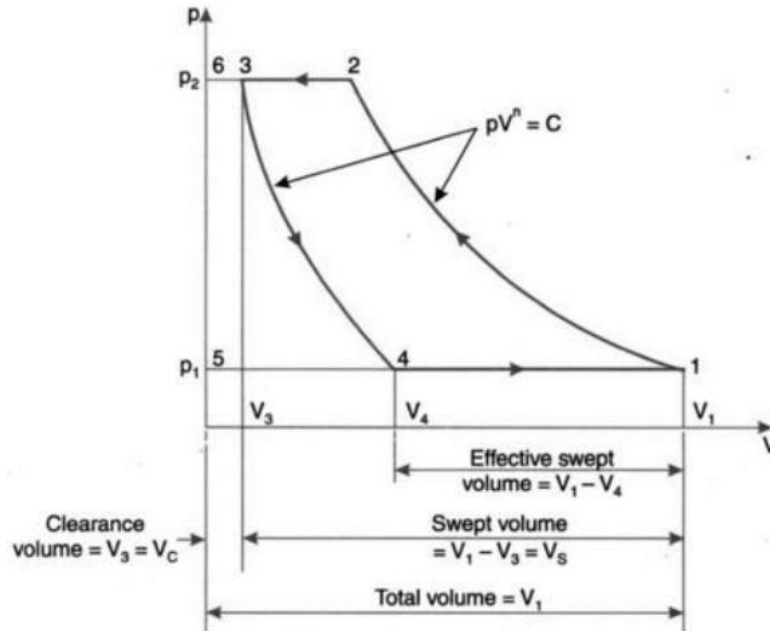

Fig: 4.6 p-V diagram with clearance volume

#### 4.11.3 Work input considering clearance volume:

Assuming the expansion (3-4) and compression (1-2) follow the law  $pV^n = C$ ,

Work input per cycle is given by,

$$W = \text{Area (1-2-3-6-5-4-1)} - \text{Area (3-6-5-4-3)}$$

$W = \text{Workdone during compression} - \text{Work done during expansion}$

$$W = \frac{n}{n-1} p_1 V_1 \left[ \left( \frac{p_2}{p_1} \right)^{\frac{n-1}{n}} - 1 \right] - \frac{n}{n-1} p_4 V_4 \left[ \left( \frac{p_3}{p_4} \right)^{\frac{n-1}{n}} - 1 \right]$$

But,  $p_3 = p_2$  and  $p_4 = p_1$

therefore

$$W = \frac{n}{n-1} p_1 V_1 \left[ \left( \frac{p_2}{p_1} \right)^{\frac{n-1}{n}} - 1 \right] - \frac{n}{n-1} p_1 V_4 \left[ \left( \frac{p_2}{p_1} \right)^{\frac{n-1}{n}} - 1 \right]$$

$$W = \frac{n}{n-1} p_1 (V_1 - V_4) \left[ \left( \frac{p_2}{p_1} \right)^{\frac{n-1}{n}} - 1 \right] \text{ kJ/cycle}$$

$V_1 - V_4$  is called as effective suction volume.

#### 4.12 Volumetric efficiency:

The clearance volume in a compressor reduces the intake capacity of the cylinder. This leads to a term called volumetric efficiency.

The volumetric efficiency is defined as the volume of free air sucked into the compressor per cycle to the stroke volume of the cylinder, the volume measured at the intake pressure and temperature or at standard atmospheric conditions, ( $p_s = 101.325 \text{ kN/m}^2$  and  $T_s = 288\text{K}$ )

$$\begin{aligned} \text{Volumetric efficiency, } \eta_{\text{vol}} &= \frac{\text{Volume of free air taken in per cycle}}{\text{Stroke volume of the cylinder}} \\ &= \frac{\text{Effective suction volume}}{\text{Swept volume}} = \frac{(V_1 - V_4)}{(V_1 - V_3)} = \frac{V_1 - V_4}{V_s} \end{aligned}$$

Clearance ratio: Clearance ratio is defined as, the ratio of clearance volume to swept volume. It is denoted by the letter C.

$$\text{Clearance ratio, } C = \frac{\text{Clearance volume}}{\text{Swept volume}} = \frac{V_c}{V_s} = \frac{V_c}{V_1 - V_3}$$

$$\text{Pressure ratio, } R_p = \frac{\text{Delivery pressure}}{\text{Suction pressure}} = \frac{p_2}{p_1} = \frac{p_3}{p_4}$$

##### 4.12.1 Expression for Volumetric efficiency

Let the compression and expansion follows the law,  $pV^n = \text{Constant}$ .

$$\text{Clearance ratio, } C = \frac{\text{Clearance volume}}{\text{Swept volume}} = \frac{V_c}{V_s} = \frac{V_3}{V_1 - V_3}$$

$$V_1 - V_3 = \frac{V_3}{C} \quad \text{-----(1)}$$

$$V_1 = \frac{V_3}{C} + V_3$$

$$V_1 = V_3 \left( \frac{1}{C} + 1 \right) \quad \text{----- (2)}$$

We know that, Pressure ratio,  $R_p = \frac{\text{Delivery pressure}}{\text{Suction pressure}} = \frac{p_2}{p_1} = \frac{p_3}{p_4}$

By polytropic expansion process 3-4:

$$\frac{p_3}{p_4} = \left( \frac{V_4}{V_3} \right)^n$$

$$\frac{V_4}{V_3} = \left( \frac{p_3}{p_4} \right)^{1/n} = (R_p)^{\frac{1}{n}}$$

$$\text{Therefore, } V_4 = V_3 (R_p)^{\frac{1}{n}} \quad \text{----- (3)}$$

$$\text{Volumetric efficiency, } \eta_{\text{vol}} = \frac{\text{Effective suction volume}}{\text{Swept volume}} = \frac{(V_1 - V_4)}{(V_1 - V_3)} \quad \text{----- (4)}$$

Using equations 1,2 and 3 in 4,

$$\eta_{\text{vol}} = \frac{V_3 \left( \frac{1}{C} + 1 \right) - V_3 [R_p]^{1/n}}{\frac{V_3}{C}} = \frac{V_3 \left\{ \left( \frac{1}{C} + 1 \right) - [R_p]^{1/n} \right\}}{V_3 \left( \frac{1}{C} \right)} = \frac{\left\{ \left( \frac{1}{C} + 1 \right) - [R_p]^{1/n} \right\}}{\left( \frac{1}{C} \right)} = C \left[ \left( \frac{1}{C} + 1 \right) - [R_p]^{1/n} \right]$$

$$\eta_{\text{vol}} = 1 + C - C [R_p]^{1/n} = 1 + C - C \left[ \frac{p_2}{p_1} \right]^{1/n}$$

#### 4.13 Multi-stage air compressor:

In a multi stage air compressor, compression of air takes place in more than one cylinder. Multi stage air compressor is used in places where high pressure air is required. Fig. shows the general arrangement of a two-stage air compressor. It consists of a low pressure (L.P) cylinder, an intercooler and a high pressure (H.P) cylinder. Both the pistons (in L.P and H.P cylinders) are driven by a single prime mover through a common shaft.

Atmospheric air at pressure  $p_1$  taken into the low pressure cylinder is compressed to a high pressure ( $p_2$ ). This pressure is intermediate between intake pressure ( $p_1$ ) and delivery pressure ( $p_3$ ). Hence this is known as intermediate pressure.

The air from low pressure cylinder is then passed into an intercooler. In the intercooler, the air is cooled at constant pressure by circulating cold water. The cooled air from the intercooler is then taken into the high pressure cylinder. In the high pressure cylinder, air is further compressed to the final delivery pressure ( $p_3$ ) and supplied to the air receiver tank.

## Tutorial Questions

|    |   |
|----|---|
| 1  | What is volumetric efficiency in case of compressor?                                      |
| 2  | Define slip factor  |
| 3  | Define pressure coefficient.  |
| 4  | What is the difference between reciprocating and rotary compressors?                      |
| 5  | What is stalling?   |
| 6  | State how the air compressors are classified?   |
| 7  | Explain the working of roots blower?  |
| 8  | Explain the working of vane blower and also draw the actual p -v diagram of a compressor? |
| 9  | What is rotary compressor how are they classified?  |
| 10 | Draw the velocity diagram of an axial flow compressor?                                    |

## Assignment Questions

|   |   |
|---|---|
| 1 | What do you mean by multistage compression? And state its advantages? |
| 2 | Draw velocity diagrams of centrifugal compressors?                    |
| 3 | Compare between reciprocating and rotary compressors?                 |
| 4 | Compare between axial flow and centrifugal compressors?               |
| 5 | Discuss of working centrifugal compressors?                           |



---

## **UNIT 5**

# **CENTRIFUGAL & AXIAL COMPRESSORS**

---





$$V_1 - V_3 = \frac{V_3}{C} \quad \text{-----(1)}$$

$$V_1 = \frac{V_3}{C} + V_3$$

$$V_1 = V_3 \left( \frac{1}{C} + 1 \right) \quad \text{----- (2)}$$

We know that, Pressure ratio,  $R_p = \frac{\text{Delivery pressure}}{\text{Suction pressure}} = \frac{p_2}{p_1} = \frac{p_3}{p_4}$

By polytropic expansion process 3-4:

$$\frac{p_3}{p_4} = \left( \frac{V_4}{V_3} \right)^n$$

$$\frac{V_4}{V_3} = \left( \frac{p_3}{p_4} \right)^{1/n} = (R_p)^{\frac{1}{n}}$$

$$\text{Therefore, } V_4 = V_3 (R_p)^{\frac{1}{n}} \quad \text{----- (3)}$$

$$\text{Volumetric efficiency, } \eta_{\text{vol}} = \frac{\text{Effective suction volume}}{\text{Swept volume}} = \frac{(V_1 - V_4)}{(V_1 - V_3)} \quad \text{----- (4)}$$

Using equations 1,2 and 3 in 4,

$$\eta_{\text{vol}} = \frac{V_3 \left( \frac{1}{C} + 1 \right) - V_3 [R_p]^{1/n}}{\frac{V_3}{C}} = \frac{V_3 \left\{ \left( \frac{1}{C} + 1 \right) - [R_p]^{1/n} \right\}}{V_3 \left( \frac{1}{C} \right)} = \frac{\left\{ \left( \frac{1}{C} + 1 \right) - [R_p]^{1/n} \right\}}{\left( \frac{1}{C} \right)} = C \left[ \left( \frac{1}{C} + 1 \right) - [R_p]^{1/n} \right]$$

$$\eta_{\text{vol}} = 1 + C - C [R_p]^{1/n} = 1 + C - C \left[ \frac{p_2}{p_1} \right]^{1/n}$$

#### 4.13 Multi-stage air compressor:

In a multi stage air compressor, compression of air takes place in more than one cylinder. Multi stage air compressor is used in places where high pressure air is required. Fig. shows the general arrangement of a two-stage air compressor. It consists of a low pressure (L.P) cylinder, an intercooler and a high pressure (H.P) cylinder. Both the pistons (in L.P and H.P cylinders) are driven by a single prime mover through a common shaft.

Atmospheric air at pressure  $p_1$  taken into the low pressure cylinder is compressed to a high pressure ( $p_2$ ). This pressure is intermediate between intake pressure ( $p_1$ ) and delivery pressure ( $p_3$ ). Hence this is known as intermediate pressure.

The air from low pressure cylinder is then passed into an intercooler. In the intercooler, the air is cooled at constant pressure by circulating cold water. The cooled air from the intercooler is then taken into the high pressure cylinder. In the high pressure cylinder, air is further compressed to the final delivery pressure ( $p_3$ ) and supplied to the air receiver tank.

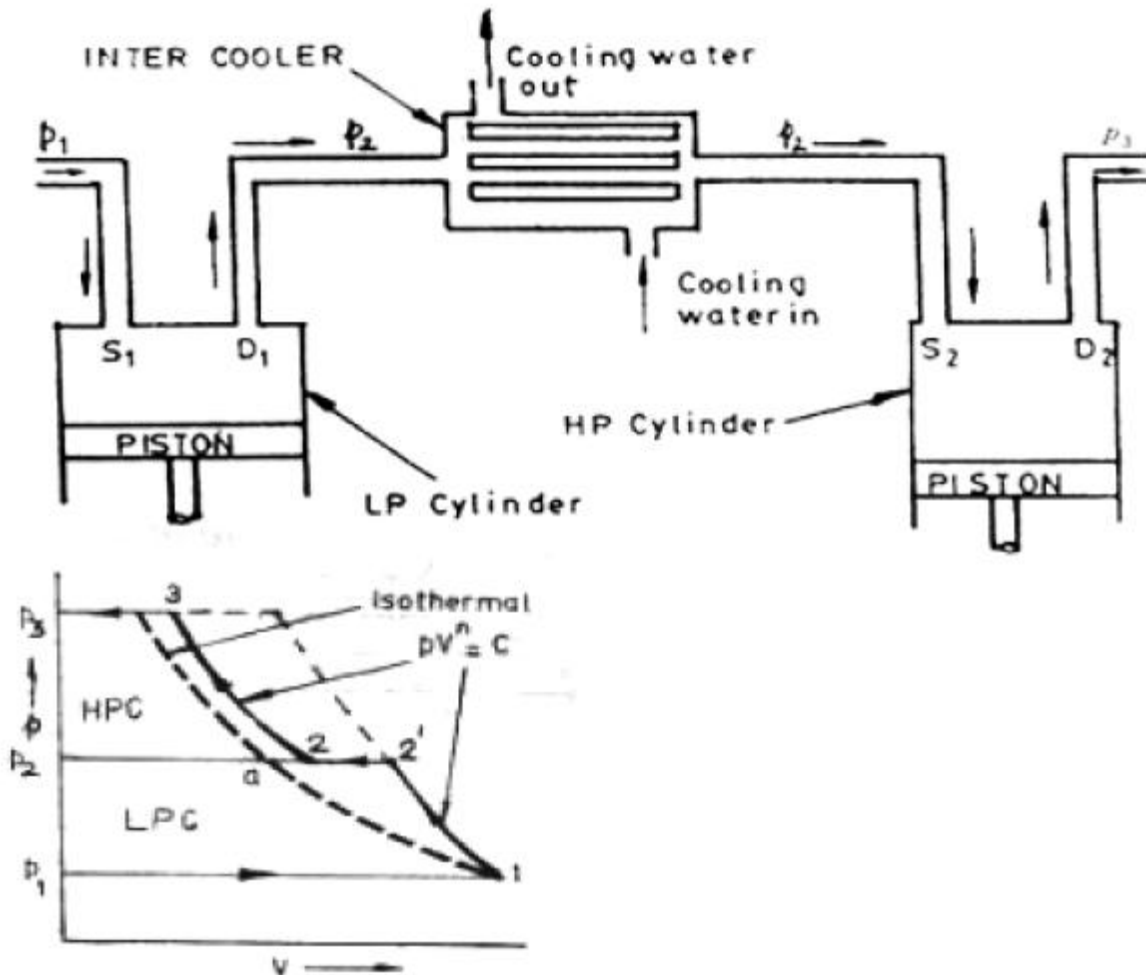

### Advantages:

- 1. Saving in work input:** The air is cooled in an intercooler before entering the high pressure cylinder. Hence less power is required to drive a multistage compressor as compared to a single stage compressor for delivering same quantity of air at the same delivery pressure.
- 2. Better balancing:** When the air is sucked in one cylinder, there is compression in the other cylinder. This provides more uniform torque. Hence size of the flywheel is reduced.
- 3. No leakage and better lubrication:** The pressure and temperature ranges are kept within desirable limits. This results in a) Minimum air leakage through the piston of the cylinder and b) effective lubrication due to lower temperature.
- 4. More volumetric efficiency:** For small pressure range, effect of expansion of the remnant air (high pressure air in the clearance space) is less. Thus by increasing number of stages, volumetric efficiency is improved.
- 5. High delivery pressure:** The delivery pressure of air is high with reasonable volumetric efficiency.
- 6. Simple construction of LP cylinder:** The maximum pressure in the low pressure cylinder is less. Hence, low pressure cylinder can be made lighter in construction.

**7. Cheaper materials:** Lower operating temperature permits the use of cheaper materials for construction.

**Disadvantages:**

1. More than one cylinder is required.
2. An intercooler is required. This increases initial cost. Also space required is more.
3. Continuous flow of cooling water is required.
4. Complicated in construction.

**4.14 Intercoolers:**

An intercooler is a simple heat exchanger. It exchanges the heat of compressed air from the LP compressor to the circulating water before the air enters the HP compressor. It consists of a number of special metal tubes connected to corrosion resistant plates at both ends. The entire nest of tubes is covered by an outer shell

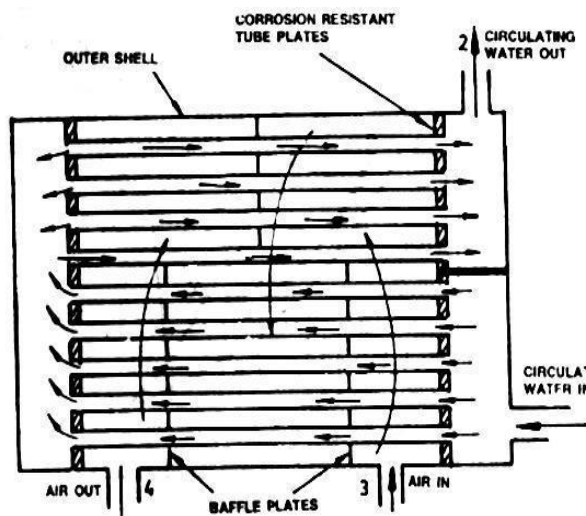

**Working:** Cold water enters the bottom of the intercooler through water inlet (1) and flows into the bottom tubes. Then they pass through the top tubes and leaves through the water outlet (2) at the top. Air from LP compressor enters through the air inlet (3) of the intercooler and passes over the tubes. While passing over the tubes, the air is cooled (by the cold water circulated through the tubes). This cold air leaves the intercooler through the air outlet (4). Baffle plates are provided in the intercooler to change the direction of air. This provides a better heat transfer from air to the circulating water.

**4.15 Work input required in multistage compressor:**

The following assumptions are made for calculating the work input in multistage compression.

1. Pressure during suction and delivery remains constant in each stage.
2. Intercooling takes place at constant pressure in each stage.
3. The compression process is same for each stage.
4. The mass of air handled by LP cylinder and HP cylinder is same.
5. There is no clearance volume in each cylinder.
6. There is no pressure drop between the two stages, i.e., exhaust pressure of one stage is

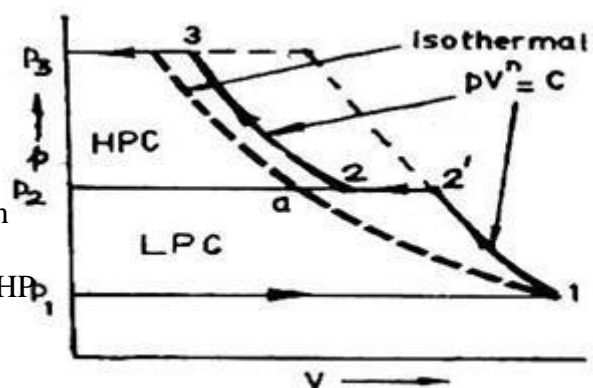

Work required to drive the multi-stage compressor can be calculated from the area of the p - V diagram .

Let,  $p_1, V_1$  and  $T_1$  be the condition of air entering the LP cylinder.  $P_2, V_2$  and  $T_2$  be the condition of air entering the HP cylinder.  
 $p_3$  be the final delivery pressure of air.

Then,

Total work input = Work input for LP compressor + Work input for HP compressor.

$$W = \frac{n}{n-1} p_1 V_1 \left[ \left( \frac{p_2}{p_1} \right)^{\frac{n-1}{n}} - 1 \right] + \frac{n}{n-1} p_1 V_1 \left[ \left( \frac{p_3}{p_2} \right)^{\frac{n-1}{n}} - 1 \right] \text{ kJ/cycle}$$

$$W = \frac{n}{n-1} m R T_1 \left[ \left( \frac{p_2}{p_1} \right)^{\frac{n-1}{n}} - 1 \right] + \frac{n}{n-1} m R T_2 \left[ \left( \frac{p_3}{p_2} \right)^{\frac{n-1}{n}} - 1 \right] \text{ kJ/cycle}$$

If intercooling is perfect,  $T_2 = T_1$ , therefore,

$$W = \frac{n}{n-1} m R T_1 \left[ \left( \frac{p_2}{p_1} \right)^{\frac{n-1}{n}} - 1 \right] + \frac{n}{n-1} m R T_1 \left[ \left( \frac{p_3}{p_2} \right)^{\frac{n-1}{n}} - 1 \right] \text{ kJ/cycle}$$

$$W = \frac{n}{n-1} m R T_1 \left[ \left( \frac{p_2}{p_1} \right)^{\frac{n-1}{n}} + \left( \frac{p_3}{p_2} \right)^{\frac{n-1}{n}} - 2 \right] \text{ kJ/cycle}$$

**4.16 Condition for maximum efficiency (or)  
Condition for minimum work input (or)**

**To prove that for minimum work input the intermediate pressure of a two-stage compressor with perfect intercooling is the geometric mean of the intake pressure and delivery pressure (or)**

**To prove  $p_2 = \sqrt{p_1 p_3}$**

Work input for a two-stage air compressor with perfect intercooling is given by,

$$W = \frac{n}{n-1} p_1 V_1 \left[ \left( \frac{p_2}{p_1} \right)^{\frac{n-1}{n}} + \left( \frac{p_3}{p_2} \right)^{\frac{n-1}{n}} - 2 \right] \text{ kJ/cycle}$$

If the initial pressure ( $p_1$ ) and final pressure ( $p_3$ ) are fixed, the value of intermediate pressure ( $p_2$ ) can be determined by differentiating the above equation of work input in terms of  $p_2$  and equating it to zero.

Let,  $\frac{n}{n-1} p_1 V_1 = k$  (constant) and  $\frac{n-1}{n} = a$

then,

$$W = k \left[ \left( \frac{p_2}{p_1} \right)^a + \left( \frac{p_3}{p_2} \right)^a - 2 \right]$$

or

$$W = k(p_2^a p_1^{-a} + p_3^a p_2^{-a} - 2) \text{ ----- (1)}$$

Differentiating the above equation (1) with respect to  $p_2$  and equating it to zero,

$$\frac{dW}{dp_2} = k a p_2^{a-1} p_1^{-a} + k (-a) p_3^a p_2^{-a-1} = 0$$

$$k a \frac{p_2^a}{p_2 p_1^a} - k a p_3^a \frac{1}{p_2^a p_2} = 0$$

or

$$\frac{k a p_2^a}{p_2 p_1^a} = \frac{k a p_3^a}{p_2 p_2^a}$$

$$\left( \frac{p_2}{p_1} \right)^a = \left( \frac{p_3}{p_2} \right)^a$$

$$\Rightarrow p_2^2 = p_1 p_3$$

or

intermediate pressure,  $p_2 = \sqrt{p_1 p_3}$

Thus for maximum efficiency the intermediate pressure is the geometric mean of the initial and final pressures.

#### 4.17 Minimum work input for multistage compression with perfect intercooling:

Work input for a two-stage compressor with perfect intercooling is given by

$$W = \frac{n}{n-1} p_1 V_1 \left[ \left( \frac{p_2}{p_1} \right)^{\frac{n-1}{n}} + \left( \frac{p_3}{p_2} \right)^{\frac{n-1}{n}} - 2 \right] \text{----- (1)}$$

Work input will be minimum if  $\frac{p_2}{p_1} = \frac{p_3}{p_2}$  ----- (2)

$$p_2^2 = p_1 p_3$$

Dividing both sides by  $p_1^2$ ,

$$\left( \frac{p_2}{p_1} \right)^2 = \frac{p_3}{p_1} \quad \Rightarrow \quad \frac{p_2}{p_1} = \left( \frac{p_3}{p_1} \right)^{1/2} \text{----- (3)}$$

From (2),  $\frac{p_3}{p_2} = \frac{p_2}{p_1} = \left( \frac{p_3}{p_1} \right)^{1/2}$  ----- (4)

Substituting the equation (4) in equation (1), work input for a two stage compressor,

$$W_{min} = \frac{n}{n-1} p_1 V_1 \left[ \left( \frac{p_3}{p_1} \right)^{\frac{1}{2} \left[ \frac{n-1}{n} \right]} + \left( \frac{p_3}{p_1} \right)^{\frac{1}{2} \left[ \frac{n-1}{n} \right]} - 2 \right]$$

$$= \frac{n}{n-1} p_1 V_1 \left[ 2 \left( \frac{p_3}{p_1} \right)^{\frac{n-1}{2n}} - 2 \right]$$

$$W_{min} = \frac{2n}{n-1} p_1 V_1 \left[ \left( \frac{p_3}{p_1} \right)^{\frac{n-1}{2n}} - 1 \right]$$

or

$$W_{min} = \frac{2n}{n-1} mRT_1 \left[ \left( \frac{p_3}{p_1} \right)^{\frac{n-1}{2n}} - 1 \right]$$

For a three stage compressor,

$$W_{min} = \frac{3n}{n-1} p_1 V_1 \left[ \left( \frac{p_4}{p_1} \right)^{\frac{n-1}{3n}} - 1 \right]$$

or

$$W_{min} = \frac{3n}{n-1} mRT_1 \left[ \left( \frac{p_4}{p_1} \right)^{\frac{n-1}{3n}} - 1 \right]$$

Generally, the minimum work input for a multistage reciprocating air compressor with  $x$  number of stages is given by,

$$W_{min} = \frac{xn}{n-1} p_1 V_1 \left[ \left( \frac{p_{x+1}}{p_1} \right)^{\frac{n-1}{xn}} - 1 \right]$$

Minimum work input required for a two stage reciprocating air compressor with perfect intercooling is given by,

$$W_{min} = \frac{2n}{n-1} p_1 V_1 \left[ \left( \frac{p_3}{p_1} \right)^{\frac{n-1}{2n}} - 1 \right] kJ$$

But, from equation (4),  $\left( \frac{p_3}{p_1} \right)^{1/2} = \frac{p_2}{p_1}$

Therefore,

$$W_{min} = \frac{2n}{n-1} p_1 V_1 \left[ \left( \frac{p_2}{p_1} \right)^{\frac{n-1}{n}} - 1 \right] kJ$$

So, for maximum efficiency i.e., for minimum work input, the work required for each stage is same.

For maximum efficiency, the following conditions must be satisfied:

1. The air is cooled to the initial temperature between the stages (Perfect cooling between stages).
2. In each stage, the pressure ratio is same.  $\left( \frac{p_2}{p_1} = \frac{p_3}{p_2} = \frac{p_4}{p_3} = \dots \right)$
3. The work input for each stage is same.

#### 4.18 Rotary compressors:

Rotary compressors have a rotor to develop pressure. They are classified as

(1) Positive displacement compressors and (2) Non positive displacement (Dynamic) compressors

In positive displacement compressors, the air is trapped in between two sets of engaging surfaces. The pressure rise is obtained by the back flow of air (as in the case of Roots blower) or both by squeezing action and back flow of air (as in the case of vane blower). Example: (1) Roots blower, (2) Vane blower, (3) Screw compressor.

In dynamic compressors, there is a continuous steady flow of air. The air is not positively contained within certain boundaries. Energy is transferred from the rotor of the compressor to the air. The pressure rise is primarily due to dynamic effects.

Example: (1) Centrifugal compressor, (2) Axial flow compressor.

##### 4.18.1 Roots blower: The Roots blower is a development of the gear pump.

**Construction:** It consists of two lobed rotors placed in separate parallel axis of a casing as shown in fig:4.11. The two rotors are driven by a pair of gears (which are driven by the prime mover) and they revolve in opposite directions. The lobes of the rotor are of cycloid shape to ensure correct mating. A small clearance of 0.1 mm to 0.2 mm is provided between the lobe and casing. This reduces the wear of moving parts.

**Working:** When the rotor is driven by the gear, air is trapped between the lobes and the casing. the trapped air moves along the casing and discharged into the receiver. There is no increase in pressure since the flow area from entry to exit remains constant. But, when the outlet is opened, there is a back flow of high pressure air in the receiver. This creates the rise in pressure of the air delivered. These types of blowers are used in automobiles for supercharging.

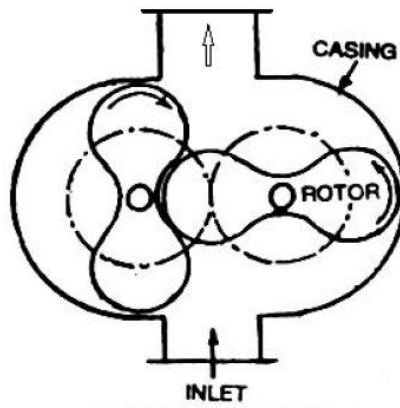

Fig:4.11 Roots blower

**Construction:** A vane blower consists of (1) a rotor, (2) vanes mounted on the rotor, (3) inlet and outlet ports and (4) casing. The rotor is placed eccentrically in the outer casing. Concentric vanes (usually 6 to 8 nos.) are mounted on the rotor. The vanes are made of fiber or carbon. Inlet suction area is greater than outlet delivery area.

**Vane blower**

**Working:** When the rotor is rotated by the prime mover, air is entrapped between two consecutive vanes. This air is gradually compressed due to decreasing volume between the rotor and the outer casing. This air is delivered to the receiver. This partly compressed air is further increased in pressure due to the back flow of high pressure air from the receiver.

**Advantages:** 1. Very simple and compact, 2. High efficiency 3. Higher speeds are possible

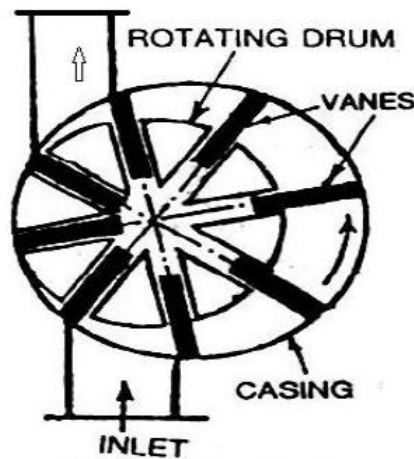

Fig: 4.12 Vane blower

**4.18.3 Centrifugal compressor**

**Construction:** It consists of an impeller, a casing and a diffuser. The impeller consists of a number of blades or vanes, is mounted on the compressor shaft inside the casing. The impeller is surrounded by the casing.

**Working:** In this compressor air enters axially and leaves radially. When the impeller rotates, air enters axially through the eye of the impeller with a low velocity. This air moves over the impeller vanes. Then, it flows radially outwards from the impeller. The velocity and pressure increases in the impeller. The air then enters the diverging passage known as diffuser. In the diffuser, kinetic energy is converted into pressure energy and the pressure of the air further increases. It is shown in fig:4.14. Finally, high pressure air is delivered to the receiver. Generally half of the total pressure rise takes place in the impeller and the other half in the diffuser.

**Applications:** Centrifugal compressors are used for low pressure units such as for refrigeration, supercharging of internal combustion engines, etc.

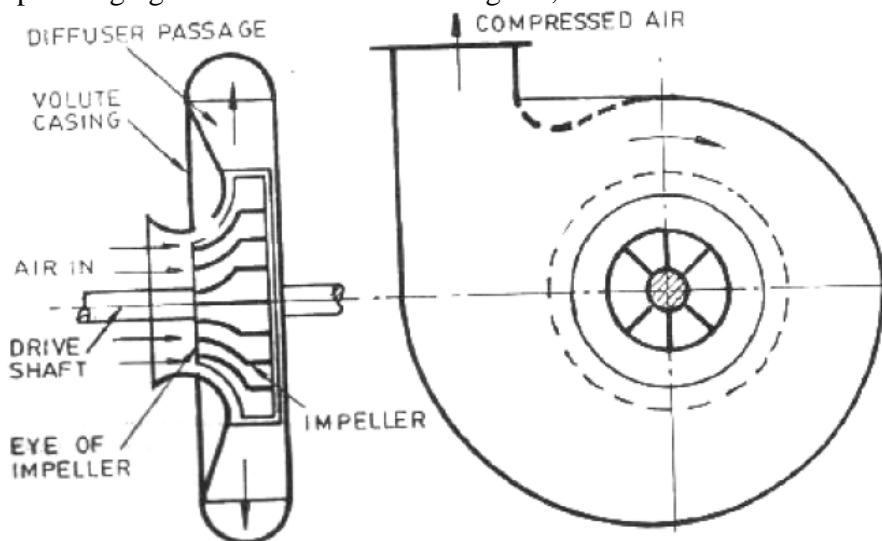

#### 4.18.4 Axial flow compressor

In this air compressor, air enters and leaves axially.

**Construction:** It consists of two sets of blades: Rotor blades and stator blades. The blades are so arranged that the unit consists of adjacent rows of rotor blades and stator blades as shown in fig:4.15. The stator blades are fixed to the casing. The rotor blades are fixed on the rotating drum. The drum is rotated by a prime mover through a driving shaft. Single stage compressor consists of a row of rotor blades followed by a row of stator blades. Compression of air takes place in each pair of blades (one rotor blade and one stator blade). Hence there are many stages of compression in this type of compressor.

**Working:** When the switch is switched on, the prime mover rotates the drum. Air enters through the compressor inlet and passes through the rotor and stator blades. While passing

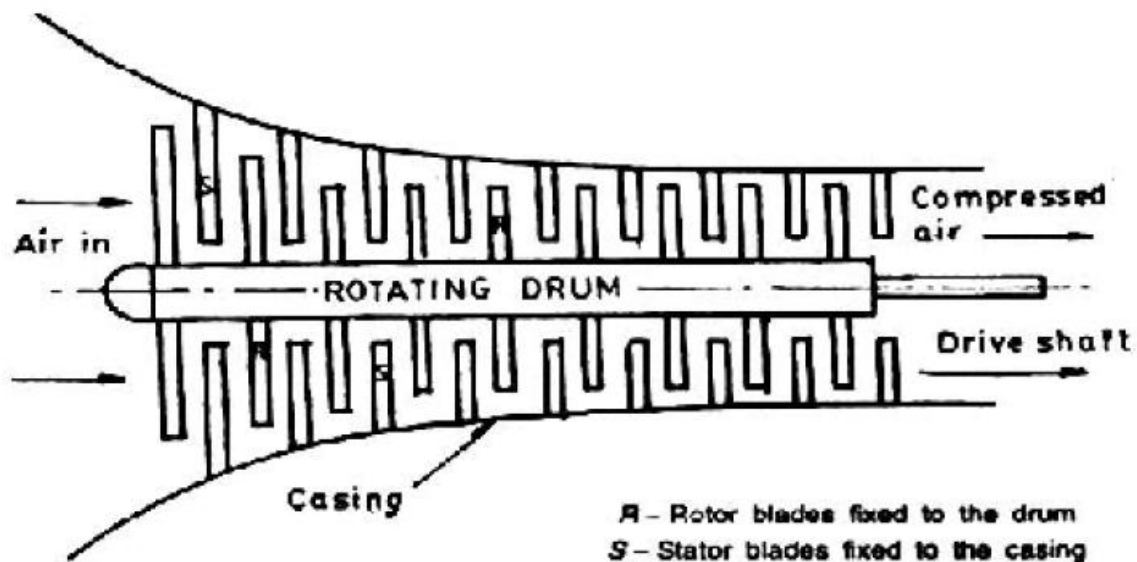

**Fig:4.15 Axial flow compressor**

Applications:

1. They are widely used in high pressure units such as industrial and marine gas turbine plants,
2. They are most suitable for aircraft work (Jet propulsion) since they require less frontal area.

## Tutorial Questions

|    |  |
|----|--|
| 1  | What is the difference between rotary compressor and reciprocating compressor? |
| 2  | Draw the diagram of Roots blower compressor?                                   |
| 3  | Draw the diagram of Vane blower compressor?                                    |
| 4  | What is the working principle of centrifugal compressor?                       |
| 5  | What is the importance of velocity triangle in centrifugal compressor?         |
| 6  | What is the mechanical efficiency of compressor?                               |
| 7  | State five uses of compressors?  |
| 8  | On what factors compressors are to be selected?                                |
| 9  | What is power input factor in compressor?                                      |
| 10 | Classify the types of compressors  |

## Assignment Questions

|   |  |
|---|--|
| 1 | An air compressor takes in air at 1 bar and 20 ° C and compresses it according to law $p v^{1.2} = \text{constant}$ .It is then delivered to a receiver at a constant pressure of 10 bar. $R=0.287 \text{ KJ/Kg K}$ . Determine : (i) Temperature at the end of compression (ii) Work done and heat transferred during compression per kg of air.  |
| 2 | A single –stage , double-acting compressor has a free air delivery (FAD) of 14 m <sup>3</sup> /min. measured at 1.013 bar and 150C. The pressure and temperature in the cylinder during induction are 0.95 bar 320 C. The delivery pressure is 7 bar and index of compression and expansion $n=1.3$ .The clearance volume is 5 % of the swept volume. Calculate (i) Indicated power required (ii) Volumetric efficiency.   |
| 3 | Air at 103 K Pa and 27 ° C is drawn in LP cylinder of a two stage air compressor and is isentropic ally compressed to 700 KPa. The air is then cooled at constant pressure to 37 ° C in an intercooler and is then again compressed isentropic ally to 4 MPa in the H.P cylinder, and is then delivered at this pressure Determine the power required to run the compressor if it has to deliver 30 m <sup>3</sup> of air per hour measured at inlet conditions. |
| 4 | A roots blower compresses 0.08 m <sup>3</sup> of air from 1.0 bar to 1.5 bar per revolution .Calculate the compressor efficiency.  |
| 5 | A centrifugal compressor delivers 16.5 kg/s of air with a total head pressure ratio of 4 :1 .The speed of the compressor is 1500 r.p.m. Inlet total head temperature is 20 ° C, slip factor 0.9 Power input factor 1.04 and 80 % isentropic efficiency. Calculate: Overall diameter of the impeller ii. Power input  |